



**FLUID CONNECTORS FOR HYDRAULICS**  
A COMPLETE PRODUCT RANGE





# TABLE OF CONTENTS

---

Preamble .....	i
----------------	---

## 1 - HOSES

Introduction .....	H0-1
Index .....	H0-2
Hoses by Working Pressure .....	H0-5
Hoses by Approvals .....	H0-7
Universal Traditional - Technical Information .....	H1-1
Extreme Traditional - Technical Information .....	H11-1
Extreme Isobaric - Technical Information .....	H20-1
Extreme Special Applications - Technical Information .....	H25-1

## 2 - FITTINGS

Introduction .....	F0-1
Visual Index .....	F0-2
Index .....	F0-4
Termination Ends Working Pressure .....	F0-8
MF2000 - Minifit Type - Technical Information .....	F1-i
MF2000 - Multifit Type - Technical Information .....	F2-i
MF2000 - Interlock Plus Type - Technical Information .....	F3-i
MF2000 - Interlock Plus Stainless Steel Type - Technical Information .....	F3-iii
MF2000 - Interlock Super Type - Technical Information .....	F4-i
MF2000 - Xtralock Type - Technical Information .....	F5-i
MF2000 - Spiralfit Type - Technical Information .....	F6-i
MF2000 - Push-lock Type - Technical Information .....	F7-i
MF2000 - Accessories .....	F8-i
MF3000 - OPF Type - Technical Information .....	F9-i
MF3000 - OPK Type - Technical Information .....	F10-i
MF2000 - Easy Fit Type - Technical Information .....	F11-i
MF2000 - Fast Fit Type - Technical Information .....	F12-i
MF2000 - RotoFit Type - Technical Information .....	F13-i

### 3 - QUICK COUPLINGS - Q.SAFE

Q.Safe - Quick Couplings - Introduction .....	Q0-1
Q.Safe - Quick Couplings - Index .....	Q0-3
Q.Safe - Quick Couplings - Technical Information .....	Q1-1
Q.Safe - DHI - Introduction .....	Q29-i
Q.Safe - DHI - Index .....	Q29-ii
Q.Safe - DHI - Technical Information .....	Q29-1
Q.Safe - Quick Couplings - Accessories Index .....	Q30-i
Q.Safe - Quick Couplings - Accessories and Spare Parts .....	Q30-1

### 4 - WATER CLEANING AND BLASTING

Introduction .....	W0-1
Index .....	W0-2
Visual Index .....	W0-3
Hoses - Water Cleaning - Technical Information .....	W1-1
Hoses - Water Blasting - Technical Information .....	W2-1
Fittings - MF2000 Multifit Type - Technical Information .....	W3-1
Fittings - MF2000 Blastlock Type - Technical Information .....	W4-1
Fittings - MF3000 OPF Type - Technical Information .....	W5-1
Fittings - Blastlock Type - Assembling Instructions and Recommendations .....	W6-1

### 5 - ASSEMBLY MACHINES

Introduction .....	M0-1
Index .....	M0-2
Modular Assembly Units .....	M0-4
Die Set Index .....	M0-7
Crimping Machines - Technical Information .....	M1-1
Cutting Machines - Technical Information .....	M2-1
Skiving Machines - Technical Information .....	M3-1
Marking Machines - Technical Information .....	M4-1
Insert Pushing Machines - Technical Information .....	M5-1
Test Benches - Technical Information .....	M6-1
Accessories and Tools .....	M7-1

## 6 - APPENDICES

Legend of Symbols .....	A1-1
Glossary of Terms .....	A2-1
Hose Size Conversion Chart .....	A3-1
Fluid Compatibility Chart .....	A4-1
Easy Fit Instructions .....	A5-1
Q.Safe Instructions .....	A6-1
Part Numbering System .....	A7-1
Hose Installation Guide .....	A8-1
Sales Terms and Conditions .....	A9-1



# MANULI HYDRAULICS - OUR MISSION

---

*Manuli Hydraulics, focused on achieving excellence in the design, manufacture and supply of fluid conveyance solutions, components and associated equipment for high pressure hydraulics, refrigeration and oil and marine applications.*

Just some of the application areas where Manuli Hydraulics products are used are:

- Construction and public works
- Underground and open pit mining
- Maintenance services
- Forestry
- Agriculture
- Water blasting and cleaning
- Refrigeration
- Material handling and logistics
- Industrial machines
- Industrial services
- Energy

## **Manuli Hydraulics Offers:**

- Wire spiral reinforced rubber hoses
- Wire braid reinforced rubber hoses
- Textile braid reinforced rubber hoses
- Reinforced thermoplastic hoses
- Hose fittings
- Quick couplings
- Staple-lock fittings, adaptors and valves for underground mining applications
- Assembling machines
- Hose assemblies and hose kits for mobile refrigeration systems
- Hose assemblies for water cleaning and water blasting applications
- Hose assemblies for high and very high pressure hydraulics systems
- Other fluid connectors

# INNOVATION

---

*Manuli Hydraulics R&D activities are based at the Manuli Hydraulics Innovation Centre (MHIC) in Bologna, Italy, which oversees the R&D centres in France, Poland, China and the UK. All of our research centres are equipped with advanced design, testing and validation facilities.*

The main MHIC laboratories feature special rooms that allow researchers to simulate the most extreme environmental conditions including:

- Heat
- Cold
- Fog
- Saline environments
- Vibrations

Our global R&D teams are made up of highly skilled international engineers who are dedicated to the development of integrated solutions for Manuli customers. The quality, wide selection of products and cost saving initiatives that our Innovation Centres provide allow us to better support our customers whatever their requirements.

Our Innovation Centres also focus on the development of co-design projects in confidential alliances with Original Equipment Customers. This is an additional benefit to our Partners, whilst the technological cooperation with OEMs helps our engineers to better understand the demanding and ever-evolving requirements of fluid conveying applications. Our focus on customer requirements enhances our capability and expertise in providing complete fluid connector solutions.





# QUALITY CERTIFICATIONS

*Quality and sustainable development are the driving forces of all Manuli Hydraulics' activities. Manuli Rubber Industries was the first European hydraulic components manufacturer to achieve the ISO 9001 certification in 1992 and the OHSAS certification in 2005.*

The Manuli Group facilities are compliant to ISO 9001 and ISO 14001 and have achieved the Occupational Health and Safety Assessment Series (OHSAS) certifications as the result of it's strong commitment to the preservation of people's health & safety on the work sites.

## ISO 9001 certified plants

- Manuli Rubber Industries – Italy, Innovation Centre & Headquarters
- Manuli Rubber Industries – Italy, Hydraulic Hoses
- Manuli Rubber Industries – Italy, Oil & Marine Hoses
- Manuli Hydraulics (Suzhou) – PRC, Hydraulic Hoses
- Manuli Hydraulics (Suzhou) – PRC, Hose assemblies
- Manuli Hydraulics Manufacturing (Radomsko) - Poland, Hydraulic Hoses
- Manuli Hydraulics Polska – Poland, HY Connectors, Refri & A/C systems
- Manuli Hydraulics – UK, Hose assemblies
- Manuli Hydraulics Europe – Czech Rep., Hose assemblies
- Manuli Hydraulics – India, Hose assemblies
- Manuli Hydraulics Korea – S. Korea, Hose assemblies
- Manuli Otim – France, Hose assemblies
- Techmafex – France, Assembling machines
- Fluiconnecto by Manuli – South Africa
- Fluiconnecto by Manuli – The Netherlands

## ISO 14001 certified plants

- Manuli Rubber Industries – Italy - Hydraulic Hoses
- Manuli Rubber Industries – Italy - Oil & Marine Hoses
- Manuli Hydraulics (Suzhou) – P.R.C. - Hydraulic Hoses
- Manuli Hydraulics (Suzhou) – P.R.C. - Hose assemblies
- Manuli Hydraulics Polska – Poland - HY Connectors, Refri & A/C systems
- Manuli Hydraulics UK – United Kingdom - Hose assemblies
- Manuli Hydraulics Europe – Czech Rep. - Hose assemblies
- Manuli Hydraulics Korea – Korea - Hose assemblies
- Manuli Hydraulics India - India - Hose assemblies

## OHSAS 18001 certified plants

- Manuli Hydraulics (Suzhou) – PRC, Hydraulic Hoses
- Manuli Hydraulics (Suzhou) – PRC, Hose assemblies
- Fluiconnecto by Manuli – South Africa



# QUALITY CERTIFICATIONS (CONT.)

---

## THIRD PARTY APPROVALS

Manuli products meet and exceed the highest industry standards as proven by the achievement of our extensive list of technical approvals issued by third party accreditation bodies.

### MINING APPROVALS

- FRAS (Fire Resistant and Anti-Static Australian Dept. Mineral Resource)
- MSHA (Mine Safety and Health Administration – USA)
- Polish B Safety certification
- MA (Chinese Mining Approval)

### OIL AND GAS APPROVALS

- API (American Petroleum Institute) Monogram License 7K
- API (American Petroleum Institute) Monogram License 5L
- API (American Petroleum Institute) 16D Fire test
- QS mark by AQSIQ (General Administration of Quality Supervision, Inspection and Quarantine of the People's Republic of China)

### MARINE EQUIPMENT APPROVALS

- ABS (American Bureau of Shipping)
- BV (Bureau Veritas)
- DNV-GL (Det Norske Veritas - Germanischer Lloyd)
- MED (Marine Equipment Directive)
- RINA (Italian Bureau of Shipping)
- KRS (Korean Register of Shipping)
- LR (Lloyd's Register of Shipping)
- CCS (China Classification Society)
- NKK (Nippon Kaiji Kyokai)

### GOVERNMENT SAFETY APPROVALS

- DB (DIN 5510-2) - German Railway
- DB (EN 45545-2) – Europe Railway (requested)
- CU-TR – Russian Fed. & CIS
- EN 81-2 - Safety of hydraulic elevators



# THE NETWORK

*Manuli Hydraulics aims to guarantee worldwide availability of technical and commercial support for its products and services.*

**The sales & service network is organised as follows:**

- **WHOLESALE FACILITIES** in Western & Eastern Europe, Americas, Asia and Oceania;
- **OEM ASSEMBLING FULLY OWNED FACILITIES** in Europe and East Asia;
- **OEM ALLIANCES PARTNER FACILITIES** with reliable customers in strategic markets
- **DISTRIBUTOR NETWORK** with a widespread presence all over the world



**PRODUCTION PLANTS**  
CHINA, POLAND, FRANCE,  
ITALY



**OEM UNITS**  
SOUTH KOREA, CHINA,  
INDIA, CZECH REPUBLIC,  
UK, FRANCE



**WHS BRANCHES**  
CHINA, SINGAPORE, INDIA,  
RUSSIA, GERMANY, UK,  
USA, MEXICO



**OEM ALLIANCE**  
USA, BRAZIL



**RESEARCH & INNOVATION**  
CHINA, FRANCE, INDIA,  
ITALY, POLAND

The network is integrated by services delivered through the private area of [www.manuli-hydraulics.com](http://www.manuli-hydraulics.com).

**The online platform offers:**

- Technical products database and related approvals
- Fluid compatibility and pressure loss tools
- On-line store
- Order tracking
- Claim management
- E-learning platform

# A COMPLETE PRODUCT RANGE - HOSES

---

*Manuli Hydraulics has established a worldwide market recognition for superior performance, reliability and long lasting products. Several hose ranges have also been developed for specific applications in heavy duty working conditions and for special markets needs.*

## STRUCTURE OF THE RANGE:

### UNIVERSAL HOSE RANGE

Meeting the main International Standards (SAE, DIN, EN, ISO).

- Wire spiral
- Wire braid
- Textile braid and thermoplastic hoses

### SPECIAL HOSE RANGE

Hoses specifically designed to satisfy the requirements of some of the most demanding applications in heavy duty working conditions.

### EXTREME HOSE RANGE

Designed to guarantee superior performance, exceeding the Standards in terms of:

- Temperature resistance
- Abrasion resistance
- Flame retardant cover properties
- Pressure resistance
- Ozone and weather resistance
- Flexibility, compactness and lightness.



## A COMPLETE PRODUCT RANGE - FITTINGS

*The crimped fittings range is composed of more than 6000 references meeting the most common international standards (SAE, DIN, BSP, JIC, ORFS, etc.) and specific requirements set by important OEMs.*

The entire Manuli Hydraulics fittings range is manufactured with an eco-friendly zinc plating treatment which also provides high corrosion resistance.

The Manuli range of crimped fittings comprises two major families, MF2000 (two-piece) fittings and MF3000 (one-piece) fittings.

Most MF2000 and MF3000 fittings are made from solid stock without welding.

### The crimped fittings choice includes:

- MULTIFIT - MF2000
- INTERLOCK PLUS - MF2000
- XTRALOCK - MF2000
- BLASTLOCK - MF2000
- PUSH-LOCK - MF2000
- MINIFIT - MF2000
- SPIRALFIT - MF2000
- OPF - MF3000
- OPK - MF3000

**MF2000®**

**MF3000®**



## A COMPLETE PRODUCT RANGE - SMART FITTINGS

---

*Manuli Hydraulics prides itself on it's innovative solutions to common problems encountered in real world hydraulics applications. As such we have introduced several "Smart Fittings" which are specifically designed to solve some of these issues.*

### **ROTOFIT**

A well-known Manuli Hydraulics solution designed to eliminate hose twist under external torques, which can be a major contributor to premature hose failure.

The additional advantage of RotoFit is that it is a "Direct-to-Hose" and "Direct-to-Port" solution. By eliminating the need for adaptors, the number of possible leak points is reduced.

### **EASYFIT**

EasyFit is the Manuli "threadless" fittings solution for quick and easy installation of assemblies.

This innovative termination end is fitted with a simple axial push, allowing the hose to self-align and thus improve service life. Maintenance and repair time is also drastically reduced and installation / disconnection in restricted spaces is far easier.

Moreover the "Direct-to-Port" concept eliminates the need for adaptors and the possibility of related leakages.

All EasyFit fittings have an eco-friendly coating treatment for superior corrosion performance.

### **FASTFIT**

FastFit is a "one plug" connection consisting of a male half integrated onto the hose and then inserted into the female cartridge. This easy and safe operation does not require any tools for assembly and allows easy installation in restricted areas or in complex configurations.

FastFit comes in a wide range of cartridges with direct connection on most standard ports, including BSP, SAE METRIC and NPTF.

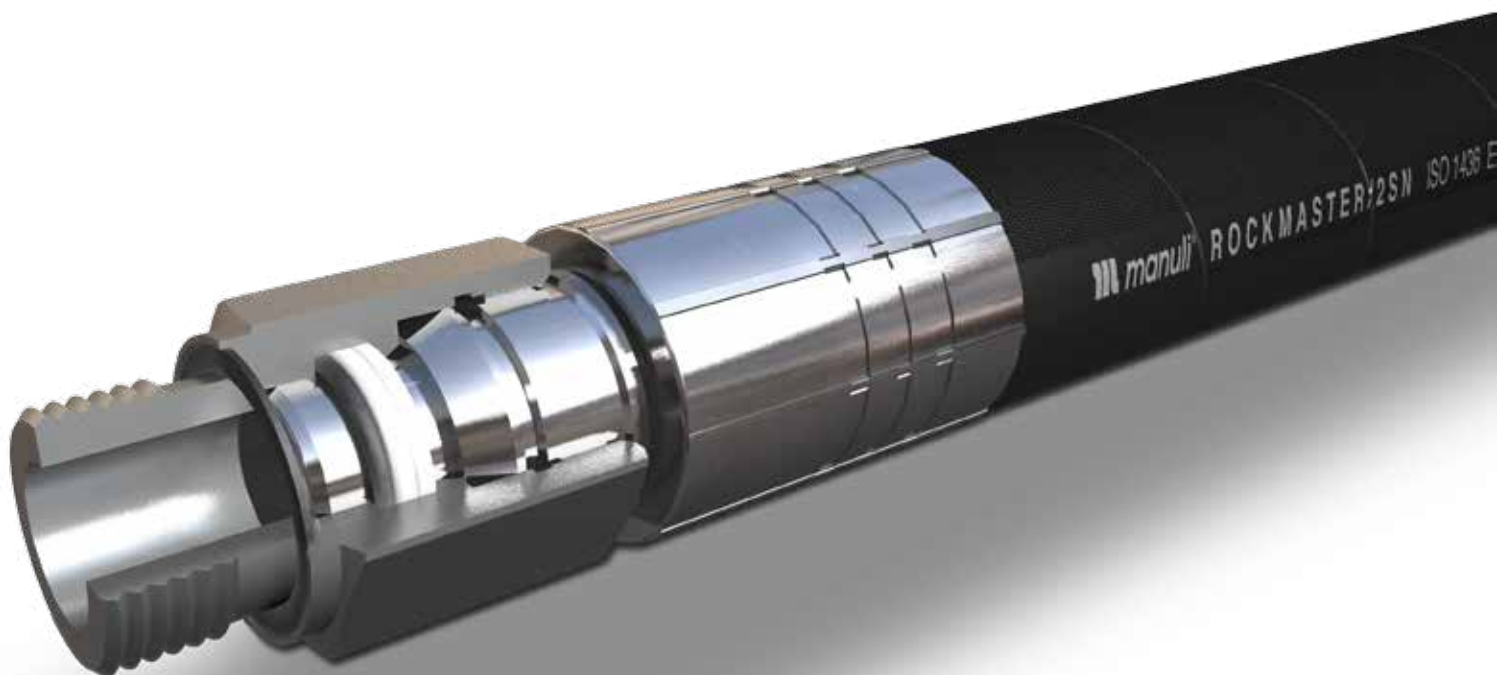

# A COMPLETE PRODUCT RANGE - QUICK COUPLINGS

*Q.Safe is the Manuli Hydraulics offering for quick coupling applications. Composed of more than 1,200 references, accessories and spare parts, the Q.Safe brand has rapidly become an industry byword for quality and performance.*

The entire Q.Safe product range is manufactured with an environmentally friendly Cr3+ (trivalent chrome) surface coating, which offers excellent resistance to corrosion; far exceeding ISO 4520 requirements (salt spray resistance: 240 hours for white corrosion and 400 for red corrosion). Guaranteeing leak-free performance, the Q.Safe brand is suitable for a wide range of different applications and assures total interchangeability with other quick coupling products on the market.

All Q.Safe products are manufactured and assembled in our world-class facility in Poland, where they are subjected to stringent quality controls including:

- 100% visual check
- 100% functional test
- 100% air sealing test

# Q.Safe

## The Q.Safe quick couplings range:

- MQS-A - ISO-A poppet and ball valves couplings
- MQS-AP - ISO-A under pressure couplings
- MQS-AM - ISO-A connectible with male under pressure
- MQS-AB - ISO-A connectible under pressure
- MQS-B - ISO-B poppet valve couplings
- MQS-BOP - ISO-B poppet valve couplings with flame test resistance to API 16D
- MQS-N - Standard poppet and ball valves couplings
- MQS-NL - Free flow couplings
- MQS-NF - Standard push-pull poppet valve couplings
- MQS-AF - Push-pull couplings
- MQS-AFP - Push-pull connectible under pressure couplings
- MQS-AFM - Push-pull connectible with male under pressure - Flexible mounting
- MQS-AFB - Push-pull connectible with both parts under pressure - Flexible mounting
- MQS-ARM - Push-pull connectible with male under pressure - Rigid mounting
- MQS-ARB - Push-pull connectible with both parts under pressure - Flexible mounting
- MQS-VB - Braking circuit valves
- MQS-VS - Agricultural valves
- MQS-D - Couplings for diagnosis
- MQS-F - Flat-Face couplings
- MQS-FH - Flat-Face high pressure couplings
- MQS-FP - Flat-Face male connectible under pressure
- MQS-FS - Flat-Face screw-type
- MQS-SG - Screw-type couplings
- MQS-SGR - Screw-type couplings for heavy duty
- MQS-SH - Screw very high pressure
- MQS-SC - Screw-type couplings for hydraulic cylinders couplings
- MQS-ST - Screw-type couplings for trucks
- MQS-CV - Check valves
- MQS-CVC - Compact Check valves
- MQS-DHI - Couplings direct hose integrated



## A COMPLETE PRODUCT RANGE - WATER CLEANING & BLASTING

---

*Manuli Hydraulics also offers a range of hoses and fittings dedicated specifically to water cleaning and blasting applications. Although different from hydraulics, our expertise in designing hoses for very high-pressure systems makes these applications a natural extension of our range.*

The water cleaning hose range offered by Manuli can be applied to both hobby and professional water cleaning machines with both hot and cold water (not suitable for vapour steam applications).

They are designed according to safety norm IEC-2 with a safety factor (burst / working pressure) of 4:1.

The water blasting hose range is designed for maximum robustness and ease of handling.

Given the importance of safety and performance when connected with any blasting application, this range has a complete, dedicated fittings range, whilst the safety factor (burst / working pressure) of 2,5:1 is compliant with international specifications (AS/NZ 4233.2, RMA-USA, ISO7751, BFPA-UK, EN1829-2)





## A COMPLETE PRODUCT RANGE - REFRIGERATION

---

*In addition to standard hydraulic products, Manuli Hydraulics also offers a complete range of reinforced rubber hoses, fittings, hose assemblies and kits for refrigeration applications.*

The Refrigeration product range is specifically designed to satisfy even the most restrictive of requirements aimed at the development of:









- Bus air conditioning and mobile refrigeration systems for “on-road industrial vehicles”;
- Air conditioning systems applied to “off-highway industrial vehicles” such as agricultural machines, earth-moving machines, forestry machines and many others.

The above systems are supplied both directly to manufacturers which need significant product volumes and through specialised distributors.

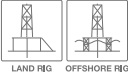

# A COMPLETE PRODUCT RANGE - DRILLING

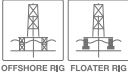
*Manuli Hydraulics is globally recognised for the reliability, high-quality and robustness of their products. In an industry where the combination of safety and efficiency is of paramount concern, you can rely on Manuli to support you across the whole spectrum of drilling applications. We understand the harsh demands of your operating environment and engineer our solutions to meet your specific requirements.*

APPLICATION	MANULI HOSE	RIG TYPE	DESIGN EXCEEDS NORMS
ROTARY/VIBRATOR HOSE	GOLDENDRILL (3000, 4000, 5000, 7500 psi)	 <small>LAND RIG   OFFSHORE RIG   FLOATER RIG</small>	API 7K FSL 1 ISO 14693 FSL 1
CEMENT HOSE	GOLDENCEMENT (10000 psi)	 <small>LAND RIG   OFFSHORE RIG   FLOATER RIG</small>	API 7K FSL 0 ISO 14693 FSL 0
BOP HOSE	GOLDENGUARD (3000, 5000 psi) GOLDENARMOUR (5000 psi)	 <small>LAND RIG   OFFSHORE RIG</small>	API 16D ISO 3862 SAE J517 
GREASE INJECTION HOSE	GOLDENDRILL/H	 <small>LAND RIG   OFFSHORE RIG   FLOATER RIG</small>	MSHA
MOTION COMPENSATOR HOSE	GOLDENWAVE	 <small>FLOATER RIG</small>	ISO 18752 - B extension SAE J517 extension MSHA
TRANSFER HOSE	XTRAFLOW/4WS	 <small>OFFSHORE RIG   FLOATER RIG</small>	ISO 18752 extension MSHA
GENERAL PURPOSE	ROCKMASTER/2SC		EN857 & ISO 11237 extension SAE 100R16, MSHA
	DIAMONDSPiR/21 DIAMONDSPiR/35	 <small>LAND RIG   OFFSHORE RIG   FLOATER RIG</small>	ISO 18752, MSHA



## A COMPLETE PRODUCT RANGE - MINING

---

*The Manuli Hydraulics brand is known throughout the hydraulics industry as the mark of a quality hose, and our extensive range of underground mining hoses are no exception.*

With several ranges of hose designed specifically to meet the needs of the underground mining industry, Manuli Hydraulics can boast compliance with the requirements of some of the most stringent and demanding approvals bodies in the industry, including:

- MSHA (USA)
- MA (China)
- Polish Safety "B"
- FRAS (Australia)

In addition our range of underground mining fittings is designed to integrate seamlessly with our hose products to deliver robust, reliable and efficient service in both the laboratory and, most importantly, in the field.

With an extensive product catalogue, covering almost all underground mining applications, Manuli Hydraulics provides both traditional and innovative hoses and fittings specifically designed with the underground mining industry in mind.



# A COMPLETE PRODUCT RANGE - HOSE PROTECTIONS

---

*Manuli Hydraulics also offers a range of strong, easy to install, and high-tech protective covers for hoses and piping. These hose protections are mainly dedicated to applications in harsh environmental conditions, where the additional protection offered is a key factor to prevent injury, fluid jetting, abrasion or hose bundling.*

In addition, the use of hose protections can significantly reduce downtime and maintenance cost.

The Manuli Hydraulics hose protections range meets all the safety requirements defined by international specifications such as ISO, EN and SAE.

**The “Made in Manuli” hose protection range consists of:**

## PROTECTION SPRINGS - PS

Recommended to protect hoses from abrasion and wearing with external parts in construction, agriculture and forestry applications.

## MINING PROTECTION SPRINGS - MPS

Recommended for severe mining applications to prevent hose bundling and to provide protection from harsh environmental factors such as abrasion.

## HT PROTECTION SPRINGS - HTPS

Recommended for hoses located in close proximity to hot surfaces. These protections enhance hose durability, flexibility and abrasion resistance in high temperature environments.

## TEXTILE SLEEVES - TSL

Recommended to protect the working environment by diffusing the energy of a sudden fluid jetting incident. These protections can be critical in minimising the risk of fluid injection injuries.

## FIRE SLEEVES - FSL

Recommended for hydraulic hose applications in very high temperature environments and in close proximity to sources of thermal radiation such as siderurgy, foundries, glassworks and the railways industry.

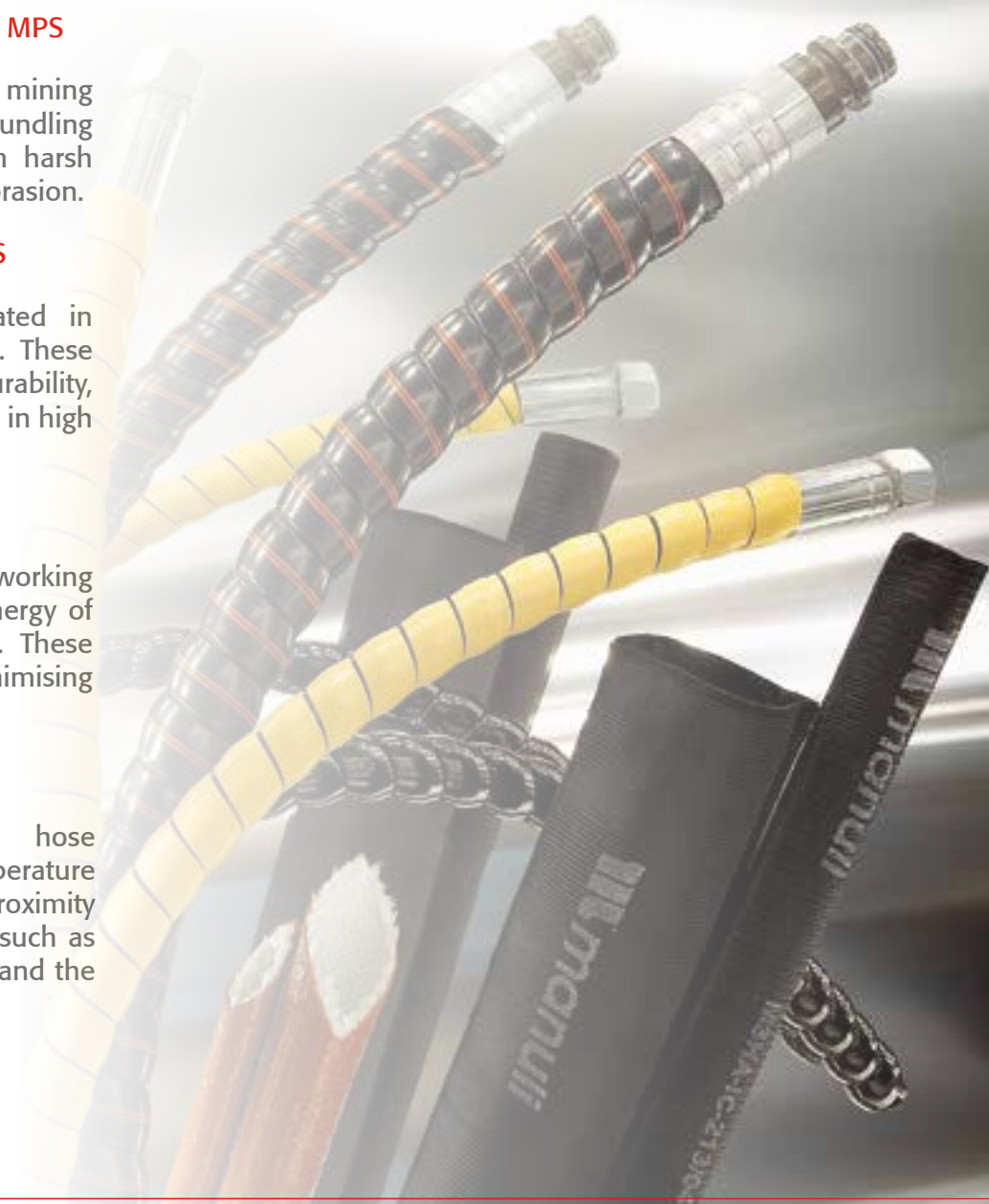

## A COMPLETE PRODUCT RANGE - ASSEMBLING MACHINES

*Manuli Hydraulics is an integrated supplier and, as such, also offers with a wide range of assembling machines, equipment, tools and operating instructions, approved to guarantee full compatibility with its own fittings solutions.*

The use of Manuli assembling machines, assembling instructions and crimping parameters is highly recommended for the production of safe, reliable hose assemblies.

### **The assembling machines range includes:**

- Crimping Machines
- Cutting Machines
- Skiving Machines
- Insert Pushing Machines
- Marking Machines
- Pressure Test Machines







**HOSES**





# HOSES

## INTRODUCTION

---

The hydraulic hose range is dedicated to hydraulic systems and equipment in many different sectors, such as construction machines, mining, industrial processes, agriculture, road construction equipment, drilling, forestry machines, material handling and lifting, road transportation, marine and offshore, and many others.

High pressure hydraulics is a means to transmit, control and distribute energy and power using a pressurised liquid, most often oil and water-based fluids, as a medium.

Manuli's UNIVERSAL hose range meets the ISO, EN, SAE, and JIS International Norms, while the EXTREME hose range is designed to meet special performance requirements in OEM severe applications. This second hose family also includes a group of hoses dedicated to Special Applications - products developed as a result of over 80 years of experience in the field.

The hose families follow traditional norms or the modern isobaric approach, which features a friendly methodology for users thanks to constant pressure levels for any size.

# HOSES INDEX

**HOSES**  
H0-2

RANGE	HOSE	HOSE STRUCTURE	NORM	KEY PERFORMANCE	SECTION	ITEM	
UNIVERSAL	TRADITIONAL	TRACTOR/1SN	Wire braided	EN 853, ISO 1436-1SN, SAE J517-100R1AT	Standard hydraulic applications	H1	1
		TRACTOR/2SN	Wire braided	EN 853, ISO 1436-2SN, SAE J517-100R-2AT	Standard hydraulic applications		2
		TRACTOR/1SC	Wire braided	EN 857, ISO 11237-1SC	Standard hydraulic applications		3
		TRACTOR/2SC	Wire braided	EN 857, ISO 11237-2SC, SAE J517-100R16	Standard hydraulic applications		4
		HARVESTER/17	Wire braided	SAE J517-100R17, ISO 11237-R17	Light and compact structure	H2	1
		GOLDENISO/14	Wire braided	ISO 18752 Type A	Compact, high flexibility	H3	1
		LYTE-FLEX	Wire braided	Manuli Design (compact wire braided)	High flexibility	H4	1
		COVER	Wire braided	SAE J517-100 R5	General purpose hose	H5	1
		SPIRTEX/K	Textile / Helix wire	SAE J517-100 R4	High quality suction hose	H6	1
		MULTITEX	Textile	SAE J517-100 R6, EN 854, ISO 4079 R6/1TE	Universal low pressure solution	H7	1
		ASTRO/2	Textile	EN 854, ISO 4079-2TE	Medium pressure solution	H8	1
		ASTRO/3	Textile	EN 854, ISO 4079-3TE	Medium pressure solution		2
		HYDROPLAST	Textile	EN 855, ISO 3949-R7, SAE J517-R100R7	Thermoplastic solution	H9	1
		HYDROTWIN	Textile	EN 855, ISO 3949-R7, SAE J517-R100R7	Twinned thermoplastic solution	H10	1
EXTREME	TRADITIONAL	ROCKMASTER/1SN	Wire braided	EN 853, ISO 1436-1SN, SAE J517-100R1AT	Abrasion, weather & heat resistance	H11	1
		ROCKMASTER/2SN	Wire braided	EN 853, ISO 1436-2SN, SAE J517-100R2AT	Abrasion, weather & heat resistance		2
		ROCKMASTER/2ST	Wire braided	EN 853, ISO 1436-2ST	Abrasion, weather & heat resistance		3
		ROCKMASTER/2 PLUS	Wire braided	EN 853, ISO 1436-2SN, SAE J517-100R2AT, perf. BCS174, ISO 6805-4	Abrasion, weather & heat resistance		4
		ROCKMASTER/1SC	Wire braided	EN 857, ISO 11237-1SC	Abrasion, weather & heat resistance		5
		ROCKMASTER/2SC	Wire braided	EN 857, ISO 11237-2SC, SAE J517-100R16	Abrasion, weather & heat resistance		6
		ROCKMASTER/4SP	Wire spiralled	EN 856, ISO 3862-4SP	Abrasion, weather & heat resistance		7
		ROCKMASTER/4SH	Wire spiralled	EN 856, ISO 3862-4SH	Abrasion, weather & heat resistance		8
		ROCKMASTER/12	Wire spiralled	EN 856, ISO 3862-R12, SAE J517-100R12	Abrasion, weather & heat resistance		9
		ROCKMASTER/13	Wire spiralled	EN 856, ISO 3862-R13, SAE J517-100R13	Abrasion, weather & heat resistance		10
		ROCKMASTER/15	Wire spiralled	ISO 3862-R15, SAE J517-100R15	Abrasion, weather & heat resistance		11
		EQUATOR/1 (BLUE)	Wire braided	EN 853, ISO 1436-1SN, SAE J517-100R1AT	Extreme temperature	H12	1
EQUATOR/1 (BLACK)	Wire braided	EN 853, ISO 1436-1SN, SAE J517-100R1AT	Extreme temperature	2			

# HOSES INDEX

RANGE	HOSE	HOSE STRUCTURE	NORM	KEY PERFORMANCE	SECTION	ITEM	
EXTREME	TRADITIONAL	EQUATOR/2 (BLUE)	Wire braided	EN 853, ISO 1436-2SN, SAE J517-100R2AT	Extreme temperature	H12	3
		EQUATOR/2 (BLACK)	Wire braided	EN 853, ISO 1436-2SN, SAE J517-100R2AT	Extreme temperature		4
		PILOT	Wire braided	Manuli Design	Superior lightness and flexibility	H13	1
		NOZONE/2K	Wire braided	EN 857, ISO 11237-2SC	Outstanding ozone resistance	H14	1
		ETERNITY/2	Wire braided	EN 857, ISO 11237-2SC, SAE J517-100R16	High service-life and reliability	H15	1
		DIAMONDSPIR	Wire spiralled	ISO 3862-R15, SAE J517-100R15	Very high pressure rating	H16	1
		SHIELDMASTER/2 PLUS MINE	Wire braided	EN 853, ISO 1436-2SN, SAE J517-100R2AT, perf. BCS174, ISO 6805-4	Outstanding abrasion resistance, MSHA approved	H17	1
		PUSHFIT	Textile	Manuli Design	Push-on hose	H18	1
		XTRAFLOW/2WB	Wire braided	Ext. EN 857-2SC, ISO 11237-2SC	High flow rates, low pressure drops	H19	1
		XTRAFLOW/4WS	Wire spiralled	Manuli Design	High flow rates, outstanding abrasion resistance		2
		XTRAFLOW/HT	Wire braided	Manuli Design	High temperature, suction and return lines		3
	ISOBARIC	GOLDENISO/21 ANTIWEAR	Wire braided	ISO 18752-A, ISO 11237-R17, SAE J517-100R17	Extreme abrasion resistance	H20	1
		GOLDENISO/28 ANTIWEAR	Wire braided	ISO 18752-A, ISO 11237-R19, SAE J517-100R19	Extreme abrasion resistance		2
		GOLDENISO/21 XTRAFLEX	Wire spiralled	ISO 18752-C/D, JIS K6349	Extreme flexibility		3
		GOLDENISO/28 XTRAFLEX	Wire spiralled	ISO 18752-C/D, JIS K6349	Extreme flexibility		4
		GOLDENISO/35 XTRAFLEX	Wire spiralled	ISO 18752-C/D, JIS K6349	Extreme flexibility		5
		GOLDENISO/42 XTRAFLEX	Wire spiralled	ISO 18752-C/C Plus	Extreme flexibility		6
		GOLDENISO/35 LONGLIFE	Wire braided	ISO 18752-B	High fatigue resistance		7
		GOLDENISO/38 LONGLIFE	Wire spiralled	ISO 18752-C/D	High fatigue resistance		8
		GOLDENISO/45 LONGLIFE	Wire spiralled	ISO 18752-D ext., ISO 11237-R15, SAE J517-100R15	High fatigue resistance		9
		SHIELDMASTER/2000	Wire braided	Manuli Design	Outstanding abrasion resistance		H21
SHIELDMASTER/4000	Wire braided and spiralled	Manuli Design	Outstanding abrasion resistance	2			
SHIELDMASTER/5000	Wire braided and spiralled	Manuli Design	Outstanding abrasion resistance	3			
SHIELDMASTER/6000	Wire braided and spiralled	Manuli Design	Outstanding abrasion resistance	4			
SHIELDMASTER/5000 MINE	Wire braided and spiralled	perf. BCS174, ISO 6805	Outstanding abrasion resistance, MSHA approved	5			
SHIELDMASTER/6000 MINE	Wire spiralled	ISO 3862-R15, SAE J517-100R15, perf. BCS174, ISO 6805-6	Outstanding abrasion resistance, MSHA approved	6			
SHIELDMASTER/17 WS	Wire spiralled	EN 856 R12, ISO 3862 R12, SAE J517-100R12	Outstanding abrasion resistance	7			

# HOSES INDEX

RANGE		HOSE	HOSE STRUCTURE	NORM	KEY PERFORMANCE	SECTION	ITEM
EXTREME	ISOBARIC	DIAMONDSPIR/14	Wire spiralled	ISO 18752-C ext.	High flow rates, outstanding abrasion resistance	H22	1
		DIAMONDSPIR/21	Wire spiralled	ISO 18752-C ext.	Very high hydraulic power transmission		2
		DIAMONDSPIR/35	Wire spiralled	ISO 18752-C ext.	Very high hydraulic power transmission		3
		FORESTMASTER/35	Wire spiralled	Manuli Design, ref. ISO 18752-C	Forestry machines, extreme abrasion resistance	H23	1
		FORESTMASTER/42	Wire spiralled	Manuli Design, ref. ISO 18752-C	Forestry machines, extreme abrasion resistance		2
				MASTERTEX	Textile	Exceeds SAE 100 R6, ISO 4079 R6/1TE	Low pressure, high temperature
APPLICATION ORIENTED		TWINPOWER 4000	Wire braided	DN 10: ISO 11237-R19, SAE J517-R19 DN 12: ISO 11237-2SC, EN 857-2SC, SAE J517-R16	Compact, twinned hose structure, easy installations for OEMs	H25	1
		TWINPOWER 5000	Wire braided	Exceeds ISO 11237 2SC, EN 857 2SC, SAE J517 type 100R16	Compact, twinned hose structure		2
		TWINPOWER/PLUS	Wire braided	EN 857, ISO 11237-2SC, SAE J517-100R16	Compact, twinned hose structure		3
		T°REX	Wire braided	Manuli Design	Extreme temperature	H26	1
		LUBEMASTER	Wire braided	Manuli Design	Lubrication line	H27	1
		JACKMASTER	Wire braided	IJ-100, Manuli Design (ref. ISO/CD 16301)	Extreme static pressure	H28	1
		FIREND	Wire braided	EN 853, ISO 1436-1SN, SAE J517-100R1AT	Fire suppression systems	H29	1
		CPH/2SC	Wire braided	-	Cable protection hose	H30	1
		GOLDENMINE	Wire spiralled	MT/T 98	Very high hydraulic power transmission in coal mines (China)	H31	1
		GOLDENGUARD/3000	Wire spiralled	API 16D Fire Test (pr. 10.1.2), ISO 18752	Emergency hydraulics	H32	1
		GOLDENGUARD/5000	Wire spiralled	API 16D Fire Test (pr. 10.1.2), ISO 18752, ISO 3862, SAE J517-100R13	Emergency hydraulics		2
		GOLDENARMOUR	Wire spiralled	API 16D Fire Test (pr. 10.1.2), ISO 18752, ISO 3862, SAE J517 type 100R13	Emergency hydraulics	H33	1

# HOSES BY WORKING PRESSURE

HOSE SIZE	WORKING PRESSURE (bar)																				
	DN	5	6	8	10	12	16	19	22	25	28	31	35	38	46	51	60	63	76	89	102
	dash	-03	-04	-05	-06	-08	-10	-12	-16	-16	-20	-20	-24	-24	-32	-32	-38	-40	-48	-56	-64
TRACTOR/1SN		250	225	215	180	160	130	105		88		63		50		40	50				
TRACTOR/2SN		415	400	350	330	275	250	215		165		125		90		80	90				
TRACTOR/1SC			225	215	180	160	130	105		88		63		50		40		50	35		
TRACTOR/2SC			400	350	330	275	250	215		165		125		100		90		70	45		
HARVESTER/17			210	210	210	210															
GOLDENISO/14			140	140	140																
LYTE-FLEX			350	297	280	245	210	210		140											
COVER		210	210	157	140	122	105		56		43		35		24						
SPIRTEX/K							21	21		17		14		10		7		4	4	3	2
MULTITEX		35	30	30	30	30	30	30		30											
ASTRO/2			75	68	63	58	50	45		40		35									
ASTRO/3			145	130	110	93	80	70		55		45		40		33					
HYDROPLAST		210	192	187	175	140															
HYDROTWIN		210	192	187	175	140															
ROCKMASTER/1SN			225	215	180	160	130	105		90		65		50		40	50				
ROCKMASTER/2SN			400	350	350	350	250	215		175		140		100		90	90				
ROCKMASTER/2ST		415	400	350	350	350	250	215		175		140		100		90					
ROCKMASTER/2 PLUS			450		400	362	340	310		240		175		146		130			70		
ROCKMASTER/1SC			260	250	225	190	150	150		110		75		50		50					
ROCKMASTER/2SC		420	400	350	330	275	250	245		210		140		100		90		70	45		
ROCKMASTER/4SP			485		450	420	380	380		320		210		185		175					
ROCKMASTER/4SH						450	420			385		350		300		250					
ROCKMASTER/12					280	280	280	280		280		210		175		175					
ROCKMASTER/13			690		690	620		350		350		350		350		350					
ROCKMASTER/15								420		420		420		420							
EQUATOR/1			225	215	180	160	130	105		88		65		50		40		35			
EQUATOR/2			400	350	330	275	250	215		175		150		100		90					
PILOT		150	150	120	100	100															
NOZONE/2K			400	350	330	275	250	215													
ETERNITY/2			450	400	365	350	300	300		225											
DIAMONDSPIR								560		560		525		475		420					
SHIELDMASTER/2 PLUS MINE			400	400	362		310			240		175		146		130					
PUSHFIT			35	35	35	25	25	21		14											
XTRAFLOW/2WB																		105	80	35	
XTRAFLOW/4WS																		140	105	80	35
XTRAFLOW/HT																		35	35	35	
GOLDENISO/21 ANTIWEAR		210	210	210	210	210	210	210		210											
GOLDENISO/28 ANTIWEAR			280	280	280	280	280	280													
GOLDENISO/21 XTRAFLEX												210		210		210					
GOLDENISO/28 XTRAFLEX					280	280	280	280		280		280		280		280					
GOLDENISO/35 XTRAFLEX					350	350	350	350		350		350		350		350					
GOLDENISO/42 XTRAFLEX					420	420	420	420		420		420		420							
GOLDENISO/35 LONGLIFE			350		350																

HOSES

H0-5

# HOSES BY WORKING PRESSURE

HOSES  
H0-6

HOSE SIZE	WORKING PRESSURE (bar)																				
	DN	5	6	8	10	12	16	19	22	25	28	31	35	38	46	51	60	63	76	89	102
dash	-03	-04	-05	-06	-08	-10	-12	-16	-16	-20	-20	-24	-24	-32	-32	-38	-40	-48	-56	-64	
GOLDENISO/38 LONGLIFE								380		380		380		380		380					
GOLDENISO/45 LONGLIFE		460					460	460		460		450									
SHIELDMASTER/2000		140		140	140																
SHIELDMASTER/4000		276	276	276	276	276	276		276		276		276		276		276				
SHIELDMASTER/5000		345	345	345	345	345	345		345												
SHIELDMASTER/6000		420		420	420	420	420		420		420		420		420		420				
SHIELDMASTER/5000 MINE		345	345	345	345	345	345		345		345										
SHIELDMASTER/6000 MINE											420		420		420						
SHIELDMASTER/17 WS															175						
DIAMONDSPIR/14																				140	
DIAMONDSPIR/21																		210	210		
DIAMONDSPIR/35																		350	350		
FORESTMASTER/35								350		350											
FORESTMASTER/42						420	420		420		420										
MASTERTEX		30		30	30	30															
TWINPOWER 4000				280	280																
TWINPOWER 5000			350	350	350																
TWINPOWER/PLUS					310																
T°REX												43									
LUBEMASTER		210		210																	
JACKMASTER		725		725																	
FIREND		225		180	160		105		88												
GOLDENMINE																				350	
GOLDENGUARD/3000							207		207												
GOLDENGUARD/5000				345	345	345	345		345		345		345		345		345				
GOLDENARMOUR				345	345	345	345		345		345		345		345		345				

# HOSES BY APPROVALS

	HYDRAULICS, MARINE EQUIPMENT TYPE APPROVALS								MINING SAFETY TYPE APPROVALS				GOVERNMENT, SAFETY AND SPECIAL TYPE APPROVALS	
	ABS	BV	DNV-GL	KRS	LLOYD'S REGISTER	RINA	MED	NK	MSHA	POLISH "B"	FRAS	MA	Elevators EN81-2	CU-TR
TRACTOR/1SN			*											*
TRACTOR/2SN			*											*
TRACTOR/1SC			*									*		*
TRACTOR/2SC			*									*		*
HARVESTER/17					*									*
GOLDENISO/14								*						*
LYTE-FLEX					*									*
COVER														*
SPIRTEX/K														*
MULTITEX														*
ASTRO/2			*											*
ASTRO/3			*											*
HYDROPLAST														*
HYDROTWIN														*
ROCKMASTER/1SN	*	*	*	*	*		*	*	*		*	*		*
ROCKMASTER/2SN	*	*	*	*	*	*	*	*	*	*	*	*		*
ROCKMASTER/2ST		*			*			*	*	*	*			*
ROCKMASTER/2 PLUS		*	*		*			*	*	*	*			*
ROCKMASTER/1SC					*			*	*	*	*			*
ROCKMASTER/2SC	*	*	*		*	*		*	*	*	*			*
ROCKMASTER/4SP	*	*	*		*	*	*	*	*	*	*			*
ROCKMASTER/4SH	*	*	*		*	*	*	*	*	*	*			*
ROCKMASTER/12	*	*			*		*	*	*		*	*		*
ROCKMASTER/13	*	*	*		*	*	*	*	*	*	*			*
ROCKMASTER/15	*	*	*		*		*	*	*	*	*			*
EQUATOR/1	*		*		*			*	*					*
EQUATOR/1 (BLUE)	*	*	*		*		*	*	*					*
EQUATOR/2	*		*		*			*	*					*
EQUATOR/2 (BLUE)	*	*	*		*		*	*	*					*
PILOT								*	*					*
NOZONE/2K								*	*					*
ETERNITY/2	*		*				*	*	*	*	*			*
DIAMONDSPIR	*							*	*	*	*			*
SHIELDMASTER/2 PLUS MINE								*	*					*
PUSHFIT														*
XTRAFLOW/2WB								*	*					*
XTRAFLOW/4WS								*	*	*	*			*
XTRAFLOW/HT								*	*					*
GOLDENISO/21 ANTIWEAR								*	*	*	*			*
GOLDENISO/28 ANTIWEAR								*	*	*	*			*
GOLDENISO/21 XTRAFLEX								*	*	*	*			*

# HOSES BY APPROVALS

HOSES  
H0-8

	HYDRAULICS, MARINE EQUIPMENT TYPE APPROVALS								MINING SAFETY TYPE APPROVALS				GOVERNMENT, SAFETY AND SPECIAL TYPE APPROVALS	
	ABS	BV	DNV-GL	KRS	LLOYD'S REGISTER	RINA	MED	NK	MSHA	POLISH "B"	FRAS	MA	Elevators EN81-2	CU-TR
GOLDENISO/28 XTRAFLEX								*		*			*	
GOLDENISO/35 XTRAFLEX			*					*		*			*	
GOLDENISO/42 XTRAFLEX								*		*			*	
GOLDENISO/35 LONGLIFE								*					*	
GOLDENISO/38 LONGLIFE								*		*			*	
GOLDENISO/45 LONGLIFE								*		*			*	
SHIELDMASTER/2000													*	
SHIELDMASTER/4000													*	
SHIELDMASTER/5000													*	
SHIELDMASTER/6000													*	
SHIELDMASTER/5000 MINE								*		*			*	
SHIELDMASTER/6000 MINE								*		*			*	
SHIELDMASTER/17 WS								*					*	
DIAMONDSPIR/14								*					*	
DIAMONDSPIR/21								*			*		*	
DIAMONDSPIR/35								*			*		*	
FORESTMASTER/35								*					*	
FORESTMASTER/42								*					*	
MASTERTEX													*	
TWINPOWER 4000													*	
TWINPOWER 5000								*					*	
TWINPOWER/PLUS								*					*	
T°REX													*	
LUBEMASTER													*	
JACKMASTER													*	
FIREND								*					*	
CPH/2SC								*					*	
GOLDENMINE								*			*		*	
GOLDENGUARD/3000			*		*								*	
GOLDENGUARD/5000			*		*								*	
GOLDENARMOUR			*		*								*	



## TRACTOR/1SN

INTEGRATED, RELIABLE HOSE ASSEMBLY



### KEY FEATURES

- EN/DIN and new SAE rated working pressures
- Flame retardant property of the cover compound, MSHA approved
- Smooth cover FRAS approved (DN 5÷12)
- Halogen-Free hose line

### APPLICATIONS & FLUIDS

- Hydraulics: low-medium pressure lines, return lines
- Mineral oils, vegetable and rape seed oils, glycol and polyglycol based oils, synthetic ester based oils, oils in aqueous emulsion, water

### TECHNICAL DATA

PART. REF.	HOSE SIZE			R.O.D.		O.D.		MAX W.P.		BURST		MIN. BEND		WEIGHT		FITTINGS	
	DN	dash	inch	mm	inch	mm	inch	bar	psi	bar	psi	mm	inch	g/m	lb/ft	Std1	Std2
H01006005*	5	- 3	3/16"	9,5	0,37	11,5	0,45	250	3620	1000	14500	89	3,50	197	0,13	MF+M03400-03	OPF-03
H02004A06*	6	- 4	1/4"	11,2	0,44	13,2	0,52	225	3260	900	13050	100	3,94	220	0,15	MF+M03400-04	OPF-04
H02004008*	8	- 5	5/16"	12,8	0,50	14,8	0,58	215	3110	850	12320	114	4,49	270	0,18	MF+M03400-05	OPF-05
H02004010*	10	- 6	3/8"	15,1	0,59	17,1	0,67	180	2610	720	10440	127	5,00	340	0,23	MF+M03400-06	OPF-06
H02004012*	12	- 8	1/2"	18,1	0,71	20,1	0,79	160	2320	640	9280	178	7,01	400	0,27	MF+M03400-08	OPF-08
H01006016*	16	- 10	5/8"	21,3	0,84	23,3	0,92	130	1880	520	7540	200	7,87	490	0,33	MF+M03400-10	OPF-10
H01006019*	19	- 12	3/4"	25,3	1,00	27,3	1,07	105	1520	420	6090	240	9,45	610	0,41	MF+M03400-12	OPF-12
H01006025*	25	- 16	1"	33,1	1,30	35,1	1,38	88	1270	350	5070	300	11,81	920	0,62	MF+M03400-16	OPF-16
H01006032*	31	- 20	1.1/4"	40,6	1,60	43,3	1,70	63	910	250	3620	419	16,50	1260	0,85	MF+M03400-20	OPK-20
H01006040*	38	- 24	1.1/2"	47,0	1,85	49,7	1,96	50	720	200	2900	500	19,69	1470	0,99	MF+M03400-24	OPK-24
H01006051*	51	- 32	2"	60,4	2,38	63,1	2,48	40	580	160	2320	630	24,80	2075	1,39	MF+M03400-32	OPK-32
H01006060*	60	- 38	2.3/8"	68,8	2,71	71,5	2,81	50	720	200	2900	650	25,59	2210	1,49	MF+M03400-38	

#### CONTINUOUS SERVICE TEMPERATURE RANGE

-40 °F / 212 °F  
-40 °C / 100 °C

#### MAX OPERATING TEMPERATURE

121 °C, 250 °F

#### TUBE

Oil resistant synthetic rubber

#### REINFORCEMENT

One high tensile steel braid

#### COVER

Environment resistant synthetic rubber

#### APPLICABLE SPECS

EN 853 1SN; SAE 100 R1AT; ISO 1436 1SN/R1AT

#### TYPE APPROVALS

MSHA, ABS; BV; DNV-GL; FRAS; NK; CU-TR; KRS; LR;



#### Remarks:

DN 5, 16, 19, 25, 31, 38, 51, 60 references not to be used anymore on new projects: phase out planned.

## TRACTOR/2SN

INTEGRATED, RELIABLE HOSE ASSEMBLY



### KEY FEATURES

- EN/DIN and new SAE rated working pressures
- Wide range of type approvals available
- Flame retardant property of the cover compound, MSHA approved
- Halogen-Free hose line

### APPLICATIONS & FLUIDS



- Hydraulics: medium-high pressure lines
- Mineral oils, vegetable and rape seed oils, glycol and polyglycol based oils, synthetic ester based oils, oils in aqueous emulsion, water

### TECHNICAL DATA

PART. REF.	HOSE SIZE			R.O.D.		O.D.		MAX W.P.		BURST		MIN.BEND		WEIGHT		FITTINGS	
	DN	dash	inch	mm	inch	mm	inch	bar	psi	bar	psi	mm	inch	g/m	lb/ft	Std1	Std2
H01027005*	5	- 3	3/16"	11,3	0,44	13,3	0,52	415	6010	1650	23930	89	3,50	315	0,21	MF+M03400-03	OPF-03
H01027006*	6	- 4	1/4"	12,7	0,50	14,7	0,58	400	5800	1600	23200	100	3,94	370	0,25	MF+M03400-04	OPF-04
H01027008*	8	- 5	5/16"	14,3	0,56	16,3	0,64	350	5070	1400	20300	114	4,49	410	0,28	MF+M03400-05	OPF-05
H01027010*	10	- 6	3/8"	16,7	0,66	18,7	0,74	330	4780	1320	19140	127	5,00	530	0,36	MF+M03400-06	OPF-06
H01027012*	12	- 8	1/2"	19,8	0,78	21,8	0,86	275	3980	1100	15950	178	7,01	620	0,42	MF+M03400-08	OPF-08
H01027016*	16	- 10	5/8"	23,0	0,91	25,0	0,98	250	3620	1000	14500	200	7,87	720	0,48	MF+M03400-10	OPF-10
H01027019*	19	- 12	3/4"	27,0	1,06	29,0	1,14	215	3110	860	12470	240	9,45	940	0,63	MF+M03400-12	OPF-12
H01027025*	25	- 16	1"	34,8	1,37	36,8	1,45	165	2390	660	9570	300	11,81	1290	0,87	MF+M03400-16	OPF-16
H01027032*	31	- 20	1.1/4"	44,3	1,74	47,0	1,85	125	1810	500	7250	419	16,50	1944	1,31	MF+M03400-20	OPK-20
H01027040*	38	- 24	1.1/2"	50,7	2,00	53,4	2,10	90	1300	360	5220	500	19,69	2250	1,51	MF+M03400-24	OPK-24
H01027051*	51	- 32	2"	63,5	2,50	66,2	2,61	80	1160	320	4640	630	24,80	2900	1,95	MF+M03400-32	OPK-32
H01027060*	60	- 38	2.3/8"	68,8	2,71	71,5	2,81	90	1300	360	5220	650	25,59	2700	1,81	MF+M03400-38	

#### CONTINUOUS SERVICE TEMPERATURE RANGE

-40 °F / 212 °F  
-40 °C / 100 °C

#### MAX OPERATING TEMPERATURE

121 °C, 250 °F

#### TUBE

Oil resistant synthetic rubber

#### REINFORCEMENT

Two high tensile steel braids

#### COVER

Environment resistant synthetic rubber

#### APPLICABLE SPECS

EN 853 2SN; SAE 100 R2AT; ISO 1436 2SN/R2AT

#### TYPE APPROVALS

MSHA, ABS; BV; DNV-GL; CU-TR; KRS; NK; LR



#### Remarks:

DN 5, 16, 19, 25, 31, 38, 51, 60 references not to be used anymore on new projects: phase out planned.

## TRACTOR/1SC

INTEGRATED, RELIABLE HOSE ASSEMBLY



### KEY FEATURES

- High flexibility and excellent bend radius
- Low weight
- Flame retardant property of the cover compound, MSHA approved
- Halogen-Free hose line
- Vacuum resistance with SAE 100 R4 performance approved on sizes up to DN 31
- Range extension to DN 76

### APPLICATIONS & FLUIDS

- Hydraulics: low-medium pressure lines with installation constraints, pilot lines, return lines (suction lines: sizes lower or equal to DN 31)
- Mineral oils, vegetable and rape seed oils, glycol and polyglycol based oils, synthetic ester based oils, oils in aqueous emulsion, water

### TECHNICAL DATA

PART. REF.	HOSE SIZE			R.O.D.		O.D.		MAX W.P.		BURST		MIN.BEND		WEIGHT		FITTINGS	
	DN	dash	inch	mm	inch	mm	inch	bar	psi	bar	psi	mm	inch	g/m	lb/ft	Std1	Std2
H01013006*	6	- 4	1/4"	10,2	0,40	12,0	0,47	225	3260	1050	15220	50	1,97	185	0,12	MF+M03300-04	MF+M00120-04
H01013008*	8	- 5	5/16"	11,5	0,45	13,6	0,54	215	3110	1000	14500	55	2,17	215	0,14	MF+M03300-05	MF+M00120-05
H01013010*	10	- 6	3/8"	13,6	0,54	15,5	0,61	180	2610	850	12320	60	2,36	265	0,18	MF+M03300-06	MF+M00120-06
H01013012*	12	- 8	1/2"	17,1	0,67	18,9	0,74	160	2320	660	9570	70	2,76	335	0,23	MF+M00820-08	MF+M00120-08
H01013016*	16	- 10	5/8"	20,6	0,81	22,4	0,88	130	1880	620	8990	90	3,54	445	0,30	MF+M00820-10	MF+M00820-10
H01013019*	19	- 12	3/4"	23,9	0,94	25,9	1,02	105	1520	480	6960	100	3,94	540	0,36	MF+M00820-12	MF+M00820-12
H01013025*	25	- 16	1"	31,3	1,23	33,3	1,31	88	1270	400	5800	160	6,30	770	0,52	MF+M00820-16	MF+M00820-16
H01013031*	31	- 20	1.1/4"	38,4	1,51	40,9	1,61	63	910	400	5800	210	8,27	1080	0,73	MF+M00820-20	MF+M00820-20
H01013038*	38	- 24	1.1/2"	45,0	1,77	47,5	1,87	50	720	200	2900	300	11,81	1220	0,82	MF+M00820-24	
H01013051*	51	- 32	2"	58,0	2,28	60,5	2,38	40	580	160	2320	400	15,75	1630	1,10	MF+M00820-32	
H01013063*	63	- 40	2.1/2"	70,5	2,78	73,0	2,87	50	720	200	2900	760	29,92	2090	1,40	MF+M03400-40	
H01013076*	76	- 48	3"	85,0	3,35	87,7	3,45	35	500	140	2030	900	35,43	2780	1,87	MF+M03400-48	

#### CONTINUOUS SERVICE TEMPERATURE RANGE

-40 °F / 212 °F  
-40 °C / 100 °C

#### MAX OPERATING TEMPERATURE

121 °C, 250 °F

#### TUBE

Oil resistant synthetic rubber

#### REINFORCEMENT

One high tensile steel braid

#### COVER

Environment resistant synthetic rubber

#### APPLICABLE SPECS

EN 857 1SC; ISO 11237 1SC

#### TYPE APPROVALS

ABS; DNV-GL; CU-TR; LR; MSHA (only DN 63 & 76); ELEVATORS EN 8-12;



#### Remarks:

For hydraulic lift applications according to EN 81-2 specification: DN 19: WP = 50 bar - DN 25: WP = 50 bar - DN 31: WP = 50 bar. The ref. spec. EN 81-2 is identified in the standard hose branding for these specific applications.

DN 16, 31, 38, 51, 63, 76 references not to be used anymore on new projects: phase out planned.

## TRACTOR/2SC

INTEGRATED, RELIABLE HOSE ASSEMBLY



### KEY FEATURES

- High flexibility and excellent bend radius
- Low weight
- Flame retardant property of the cover compound, MSHA approved
- Halogen-Free hose line
- Range extension to DN 76
- Vacuum resistance with SAE 100 R4 performance approved on sizes up to DN 76

### APPLICATIONS & FLUIDS



- Hydraulics: medium-high pressure lines with installation constraints, return lines and suction lines
- Mineral oils, vegetable and rape seed oils, glycol and polyglycol based oils, synthetic ester based oils, oils in aqueous emulsion, water

### TECHNICAL DATA

PART. REF.	HOSE SIZE			R.O.D.		O.D.		MAX W.P.		BURST		MIN.BEND		WEIGHT		FITTINGS	
	DN	dash	inch	mm	inch	mm	inch	bar	psi	bar	psi	mm	inch	g/m	lb/ft	Std1	Std2
H01025006*	6	- 4	1/4"	11,3	0,44	13,1	0,52	400	5800	1850	26830	45	1,77	280	0,19	MF+M03400-04	OPF-04
H01025008*	8	- 5	5/16"	12,9	0,51	14,7	0,58	350	5070	1700	24650	55	2,17	330	0,22	MF+M03400-05	OPF-05
H01025010*	10	- 6	3/8"	15,0	0,59	16,8	0,66	330	4780	1500	21750	65	2,56	395	0,27	MF+M03400-06	OPF-06
H01025012*	12	- 8	1/2"	18,5	0,73	20,3	0,80	275	3980	1220	17690	80	3,15	510	0,34	MF+M03400-08	OPF-08
H01025016*	16	- 10	5/8"	21,8	0,86	23,6	0,93	250	3620	1050	15220	90	3,54	630	0,42	MF+M03400-10	OPF-10
H01025019*	19	- 12	3/4"	25,6	1,01	27,6	1,09	215	3110	920	13340	120	4,72	800	0,54	MF+M03400-12	OPF-12
H01025025*	25	- 16	1"	33,0	1,30	35,2	1,39	165	2390	720	10440	160	6,30	1130	0,76	MF+M03400-16	OPF-16
H01025031*	31	- 20	1.1/4"	41,1	1,62	43,6	1,72	125	1810	560	8120	250	9,84	1570	1,06	MF+M03400-20	OPK-20
H01025038*	38	- 24	1.1/2"	47,7	1,88	50,7	2,00	100	1450	400	5800	300	11,81	1900	1,28	MF+M03400-24	OPK-24
H01025051*	51	- 32	2"	60,4	2,38	63,4	2,50	90	1300	360	5220	400	15,75	2460	1,65	MF+M03400-32	OPK-32
H01025063*	63	- 40	2.1/2"	73,0	2,87	76,0	2,99	70	1010	300	4350	760	29,92	2980	2,00	MF+M03400-40	
H01025076*	76	- 48	3"	87,8	3,46	90,5	3,56	45	650	180	2610	900	35,43	3250	2,18	MF+M03400-48	

#### CONTINUOUS SERVICE TEMPERATURE RANGE

-40 °F / 212 °F  
-40 °C / 100 °C

#### MAX OPERATING TEMPERATURE

121 °C, 250 °F

#### TUBE

Oil resistant synthetic rubber

#### REINFORCEMENT

Two high tensile steel braids

#### COVER

Environment resistant synthetic rubber

#### APPLICABLE SPECS

EN 857 2SC; ISO 11237 2SC; SAE 100 R16

#### TYPE APPROVALS

MSHA, ABS; DNV-GL; CU-TR; LR; ELEVATORS  
EN 8-12



#### Remarks:

For hydraulic lift applications according to EN 81-2 specification: DN 31: WP = 50 bar - DN 38: WP = 50 bar - DN 51: WP = 45 bar. These ratings are identified with additional embossed branding on the hose references.

DN 16, 31, 38, 51, 63, 76 references not to be used anymore on new projects: phase out planned.

## HARVESTER/17

INTEGRATED, RELIABLE HOSE ASSEMBLY



### KEY FEATURES

- Isobaric pressure rating
- Compact hose structures for installations in narrow spaces
- Halogen-Free hose line

### APPLICATIONS & FLUIDS

- Hydraulics: medium pressure lines with installation constraints
- Mineral oils, vegetable and rape seed oils, glycol and polyglycol based oils, synthetic ester based oils, oils in aqueous emulsion, water

### TECHNICAL DATA

PART. REF.	HOSE SIZE			R.O.D.		O.D.		MAX W.P.		BURST		MIN.BEND		WEIGHT		FITTINGS	
	DN	dash	inch	mm	inch	mm	inch	bar	psi	bar	psi	mm	inch	g/m	lb/ft	Std1	Std2
H01056006*	6	- 4	1/4"	10,2	0,40	12,0	0,47	210	3040	840	12180	50	1,97	185	0,12	MF+M03300-04	OPF-04
H01056008*	8	- 5	5/16"	11,5	0,45	13,6	0,54	210	3040	840	12180	55	2,17	215	0,14	MF+M03300-05	OPF-05
H01056A10*	10	- 6	3/8"	14,4	0,57	16,2	0,64	210	3040	840	12180	65	2,56	305	0,20	MF+M03400-06	OPF-06
H01056A12*	12	- 8	1/2"	17,9	0,70	19,7	0,78	210	3040	840	12180	90	3,54	420	0,28	MF+M03400-08	OPF-08

#### CONTINUOUS SERVICE TEMPERATURE RANGE

-40 °F / 212 °F  
-40 °C / 100 °C

#### MAX OPERATING TEMPERATURE

121 °C, 250 °F

#### TUBE

Oil resistant synthetic rubber

#### REINFORCEMENT

One high tensile steel braid

#### COVER

Environment resistant synthetic rubber

#### APPLICABLE SPECS

SAE 100 R17; ISO 11237 R17

#### TYPE APPROVALS

CU-TR; LR

## GOLDENISO/14

COMPACTNESS & FLEXIBILITY



### KEY FEATURES

- Compact dimensions, smooth cover
- Very low bend radius, suitable for difficult installations
- High flexibility
- Flame retardant MSHA approved cover
- MiniFit special dedicated fittings, compact dimensions, designed for small bore 1WB hose

### APPLICATIONS & FLUIDS



- Hydraulics: low pressure lines, pilot lines, auxiliary hydraulic systems
- Mineral oils, vegetable and rape seed oils, glycol and polyglycol based oils, synthetic ester based oils, oils in aqueous emulsion, water

### TECHNICAL DATA

PART. REF.	HOSE SIZE			R.O.D.		O.D.		MAX W.P.		BURST		MIN.BEND		WEIGHT		FITTINGS	
	DN	dash	inch	mm	inch	mm	inch	bar	psi	bar	psi	mm	inch	g/m	lb/ft	Std1	Std2
H02011006*	6	- 4	1/4"	10,2	0,40	12,4	0,49	140	2030	560	8120	25	0,98	190	0,13	MN+M02400-04	OPF-04
H02011008*	8	- 5	5/16"	11,9	0,47	14,0	0,55	140	2030	560	8120	30	1,18	214	0,14	MN+M02400-05	OPF-05
H02011010*	10	- 6	3/8"	14,5	0,57	16,5	0,65	140	2030	560	8120	40	1,57	298	0,20	MN+M02400-06	OPF-06

#### CONTINUOUS SERVICE TEMPERATURE RANGE

-40 °F / 212 °F  
-40 °C / 100 °C

#### MAX OPERATING TEMPERATURE

121 °C, 250 °F

#### TUBE

Oil resistant synthetic rubber

#### REINFORCEMENT

One wire braid (DN 6 to 12) or two wire braids

#### COVER

Synthetic rubber with high ozone and wheater resistance

#### APPLICABLE SPECS

ISO 18752 type A

#### TYPE APPROVALS

CU-TR

## LYTE-FLEX

COMPACT WIRE BRAID, INTEGRATED RELIABLE HOSE ASSEMBLY



### KEY FEATURES

- Intermediate pressure rating between 1SC & 2SC
- Lightness and flexibility
- Halogen-Free hose line

### APPLICATIONS & FLUIDS

- Hydraulics: medium pressure lines with installation constraints
- Mineral oils, vegetable and rape seed oils, glycol and polyglycol based oils, synthetic ester based oils, oils in aqueous emulsion, water

### TECHNICAL DATA

PART. REF.	HOSE SIZE			R.O.D.		O.D.		MAX W.P.		BURST		MIN. BEND		WEIGHT		FITTINGS	
	DN	dash	inch	mm	inch	mm	inch	bar	psi	bar	psi	mm	inch	g/m	lb/ft	Std1	Std2
H01084006*	6	- 4	1/4"	11,6	0,46	13,2	0,52	350	5070	1400	20300	50	1,97	265	0,18	MF+M03400-04	OPF-04
H01084008*	8	- 5	5/16"	12,9	0,51	14,5	0,57	297	4300	1190	17250	55	2,17	290	0,19	MF+M03400-05	OPF-05
H01084010*	10	- 6	3/8"	15,4	0,61	17,0	0,67	280	4060	1120	16240	63	2,48	385	0,26	MF+M03400-06	OPF-06
H01084012*	12	- 8	1/2"	18,5	0,73	20,3	0,80	245	3550	980	14210	88	3,46	465	0,31	MF+M03400-08	OPF-08
H01084016*	16	- 10	5/8"	22,2	0,87	24,0	0,94	210	3040	840	12180	100	3,94	630	0,42	MF+M03400-10	OPF-10
H01084019*	19	- 12	3/4"	25,6	1,01	27,7	1,09	210	3040	840	12180	120	4,72	790	0,53	MF+M03400-12	OPF-12
H01084025*	25	- 16	1"	32,3	1,27	34,6	1,36	140	2030	560	8120	150	5,91	1090	0,73	MF+M03400-16	OPF-16

#### CONTINUOUS SERVICE TEMPERATURE RANGE

-40 °F / 212 °F  
-40 °C / 100 °C

#### MAX OPERATING TEMPERATURE

121 °C, 250 °F

#### TUBE

Oil resistant synthetic rubber

#### REINFORCEMENT

Two high tensile steel braids

#### COVER

Environment resistant synthetic rubber

#### APPLICABLE SPECS

Manuli Design; DN 16 and 19: SAE 100 R17; ISO 11237 R17

#### TYPE APPROVALS

CU-TR; LR

## COVER

INTEGRATED, RELIABLE HOSE ASSEMBLY

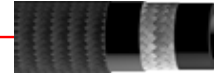

### KEY FEATURES

- Robust design, general purpose hose
- Wear resistant cover

### APPLICATIONS & FLUIDS

- Hydraulics: low-medium pressure lines, general purpose applications
- Mineral oils, vegetable and rape seed oils, glycol and polyglycol based oils, synthetic ester based oils, oils in aqueous emulsion, water, diesel fuel (up to 200°F/93°C)

### TECHNICAL DATA

PART. REF.	HOSE SIZE			R.O.D.		O.D.		MAX W.P.		BURST		MIN.BEND		WEIGHT		FITTINGS	
	DN	dash	inch	mm	inch	mm	inch	bar	psi	bar	psi	mm	inch	g/m	lb/ft	Std1	Std2
H05002005*	5	- 4	3/16"			13,2	0,52	210	3040	840	12180	75	2,95	220	0,15	MF+M00310-03	OPF-03
H05002006*	6	- 5	1/4"			14,8	0,58	210	3040	840	12180	85	3,35	260	0,17	MF+M00310-04	OPF-04
H05002008*	8	- 6	5/16"			17,1	0,67	157	2270	630	9130	100	3,94	305	0,20	MF+M00310-05	OPF-05
H05002010*	10	- 8	13/32"			19,4	0,76	140	2030	560	8120	115	4,53	365	0,25	MF+M00310-06	OPF-06
H05002012*	12	- 10	1/2"			23,3	0,92	122	1760	490	7100	140	5,51	495	0,33	MF+M00310-08	OPF-08
H05002016*	16	- 12	5/8"			27,3	1,07	105	1520	420	6090	165	6,50	650	0,44	MF+M00310-10	
H05002022*	22	- 16	7/8"			31,2	1,23	56	810	224	3240	185	7,28	600	0,40		
H05002028*	28	- 20	1.1/8"			38,0	1,50	43	620	175	2530	229	9,02	780	0,52		
H05002035*	35	- 24	1.3/8"			44,3	1,74	35	500	140	2030	265	10,43	1010	0,68		
H05002046*	46	- 32	1.13/16"			56,1	2,21	24	340	98	1420	335	13,19	1400	0,94		

#### CONTINUOUS SERVICE TEMPERATURE RANGE

-40 °F / 212 °C  
-40 °C / 100 °C

#### MAX OPERATING TEMPERATURE

121 °C, 250 °F

#### TUBE

Oil resistant synthetic rubber

#### REINFORCEMENT

One high tensile steel braid

#### COVER

One textile braid

#### APPLICABLE SPECS

SAE 100 R5

#### TYPE APPROVALS

CU-TR



## SPIRTEX/K

INTEGRATED, RELIABLE HOSE ASSEMBLY



### KEY FEATURES

- Resistance to Vacuum
- Compact SAE 100 R4 architecture

### APPLICATIONS & FLUIDS

- Hydraulics: suction lines, return lines
- Mineral oils, vegetable and rape seed oils, glycol and polyglycol based oils, synthetic ester based oils, oils in aqueous emulsion, water

### TECHNICAL DATA

PART. REF.	HOSE SIZE			R.O.D.		O.D.		MAX W.P.		BURST		MIN.BEND		WEIGHT		FITTINGS	
	DN	dash	inch	mm	inch	mm	inch	bar	psi	bar	psi	mm	inch	g/m	lb/ft	Std1	Std2
H30005016*	16	- 10	5/8"			26,0	1,02	21	300	64	920	96	3,78	590	0,40	MF+M00310-10	
H30005019*	19	- 12	3/4"			29,0	1,14	21	300	84	1210	125	4,92	550	0,37	MF+M00320-12	
H30005025*	25	- 16	1"			35,0	1,38	17	240	70	1010	150	5,91	680	0,46	MF+M00930-16	
H30005031*	31	- 20	1.1/4"			42,0	1,65	14	200	56	810	200	7,87	840	0,56	MF+M00920-20	
H30005038*	38	- 24	1.1/2"			48,5	1,91	10	140	42	600	254	10,00	1024	0,69	MF+M00910-24	
H30005051*	51	- 32	2"			61,5	2,42	7	100	28	400	300	11,81	1420	0,95	MF+M00910-32	
H30005063*	63	- 40	2.1/2"			76,0	2,99	4	50	17	240	355	13,98	2150	1,44	MF+M03400-40	
H30005076*	76	- 48	3"			88,0	3,46	4	50	16	230	457	17,99	2850	1,92	MF+M03400-48	
H30005090*	89	- 56	3.1/2"			103,0	4,06	3	40	12	170	530	20,87	3450	2,32		
H30005102*	102	- 64	4"			115,0	4,53	2	20	10	140	610	24,02	3900	2,62		

#### CONTINUOUS SERVICE TEMPERATURE RANGE

-40 °F / 212 °F  
-40 °C / 100 °C

#### TUBE

Oil resistant synthetic rubber

#### REINFORCEMENT

Two textile reinforcements with steel helical body wire

#### COVER

Environment resistant synthetic rubber

#### APPLICABLE SPECS

SAE 100 R4

#### TYPE APPROVALS

CU-TR

## MULTITEX

INTEGRATED, RELIABLE HOSE ASSEMBLY



### KEY FEATURES

- High flexibility
- Wide range of fluid compatibility
- MF2000® Multifit type couplability
- Push-On hose with MF2000® Push-Lock insert type without ferrule

### APPLICATIONS & FLUIDS



- Hydraulics: low pressure lines, return lines, drain lines
- Mineral oils, vegetable and rape seed oils, glycol and polyglycol based oils, synthetic ester based oils, oils in aqueous emulsion, water

### TECHNICAL DATA

PART. REF.	HOSE SIZE			R.O.D.		O.D.		MAX W.P.		BURST		MIN.BEND		WEIGHT		FITTINGS	
	DN	dash	inch	mm	inch	mm	inch	bar	psi	bar	psi	mm	inch	g/m	lb/ft	Std1	Std2
H09067005*	5	- 3	3/16"			11,0	0,43	35	500	140	2030	35	1,38	90	0,06	MF+M00820-03	
H09067006*	6	- 4	1/4"			12,6	0,50	30	430	120	1740	45	1,77	115	0,08	MF+M00830-04	
H09067008*	8	- 5	5/16"			14,1	0,56	30	430	120	1740	65	2,56	140	0,09	MF+M00830-05	
H09067010*	10	- 6	3/8"			15,8	0,62	30	430	120	1740	75	2,95	160	0,11	MF+M00820-06	
H09067012*	12	- 8	1/2"			19,4	0,76	30	430	120	1740	90	3,54	210	0,14	MF+M00820-08	
H09073016*	16	- 10	5/8"			23,0	0,91	30	430	120	1740	115	4,53	290	0,19	MF+M00820-10	
H09073019*	19	- 12	3/4"			26,0	1,02	30	430	120	1740	140	5,51	325	0,22	MF+M00820-12	
H09073025*	25	- 16	1"			32,0	1,26	30	430	120	1740	150	5,91	400	0,27	MF+M00820-16	

#### CONTINUOUS SERVICE TEMPERATURE RANGE

-40 °F / 257 °F  
-40 °C / 125 °C

#### TUBE

Oil resistant synthetic rubber

#### REINFORCEMENT

One high resistance textile braid

#### COVER

Environment resistant synthetic rubber

#### APPLICABLE SPECS

SAE 100 R6; EN 854 R6/1TE; ISO 4079 R6/1TE

#### TYPE APPROVALS

CU-TR



#### Remarks:

Working Pressure with Push-Lock fittings: DN 5, 6, 8, 10, 12, 16, 19: WP = 17 bar - DN 25: WP = 12 bar

## ASTRO/2

INTEGRATED, RELIABLE HOSE ASSEMBLY



### KEY FEATURES

- Wide range of fluid compatibility
- High flexibility of the hose structure

### APPLICATIONS & FLUIDS

- Hydraulics: low pressure lines, return lines
- Mineral oils, vegetable and rape seed oils, glycol and polyglycol based oils, synthetic ester based oils, oils in aqueous emulsion, water

### TECHNICAL DATA

PART. REF.	HOSE SIZE			R.O.D.		O.D.		MAX W.P.		BURST		MIN.BEND		WEIGHT		FITTINGS	
	DN	dash	inch	mm	inch	mm	inch	bar	psi	bar	psi	mm	inch	g/m	lb/ft	Std1	Std2
H09045006*	6	- 4	1/4"			13,0	0,51	75	1080	300	4350	40	1,57	125	0,08	MF+M00830-04	
H09045008*	8	- 5	5/16"			14,6	0,57	68	980	272	3940	50	1,97	150	0,10	MF+M00830-05	
H09045010*	10	- 6	3/8"			16,1	0,63	63	910	252	3650	60	2,36	180	0,12	MF+M00820-06	
H09045012*	12	- 8	1/2"			19,2	0,76	58	840	232	3360	70	2,76	220	0,15	MF+M00820-08	
H09045016*	16	- 10	5/8"			23,6	0,93	50	720	200	2900	90	3,54	290	0,19	MF+M00820-10	
H09045019*	19	- 12	3/4"			26,5	1,04	45	650	180	2610	110	4,33	360	0,24	MF+M00820-12	
H09045025*	25	- 16	1"			33,4	1,31	40	580	160	2320	130	5,12	440	0,30	MF+M00820-16	
H09045032*	31	- 20	1.1/4"			41,5	1,63	35	500	140	2030	140	5,51	650	0,44	MF+M00820-20	

#### CONTINUOUS SERVICE TEMPERATURE RANGE

-40 °F / 257 °F  
-40 °C / 125 °C

#### TUBE

Oil resistant synthetic rubber

#### REINFORCEMENT

One high resistance textile braid

#### COVER

Environment resistant synthetic rubber

#### APPLICABLE SPECS

EN 854 2TE; ISO 4079 2TE

#### TYPE APPROVALS

DNV-GL; CU-TR

## ASTRO/3

INTEGRATED, RELIABLE HOSE ASSEMBLY



### KEY FEATURES

- Wide range of fluid compatibility
- High flexibility of the hose structure
- Low bend radii and compactness
- Exceed performance of SAE100R3

### APPLICATIONS & FLUIDS



- Hydraulics: low-medium pressure lines, return lines
- Mineral oils, vegetable and rape seed oils, glycol and polyglycol based oils, synthetic ester based oils, oils in aqueous emulsion, water

### TECHNICAL DATA

PART. REF.	HOSE SIZE			R.O.D.		O.D.		MAX W.P.		BURST		MIN.BEND		WEIGHT		FITTINGS	
	DN	dash	inch	mm	inch	mm	inch	bar	psi	bar	psi	mm	inch	g/m	lb/ft	Std1	Std2
H09046006*	6	- 4	1/4"			14,2	0,56	145	2100	580	8410	45	1,77	150	0,10	MF+M00310-04	
H09046008*	8	- 5	5/16"			16,6	0,65	130	1880	520	7540	55	2,17	210	0,14	MF+M00310-05	
H09046010*	10	- 6	3/8"			18,2	0,72	110	1590	440	6380	70	2,76	230	0,15	MF+M00310-06	
H09046012*	12	- 8	1/2"			21,5	0,85	93	1340	372	5390	85	3,35	290	0,19	MF+M00310-08	
H09046016*	16	- 10	5/8"			25,6	1,01	80	1160	320	4640	105	4,13	395	0,27	MF+M00310-10	
H09046019*	19	- 12	3/4"			28,8	1,13	70	1010	280	4060	130	5,12	455	0,31	MF+M00320-12	
H09046025*	25	- 16	1"			35,4	1,39	55	790	220	3190	150	5,91	580	0,39	MF+M00310-16	
H09046032*	31	- 20	1.1/4"			42,5	1,67	45	650	180	2610	190	7,48	740	0,50	MF+M00310-20	
H09046040*	38	- 24	1.1/2"			49,4	1,94	40	580	160	2320	240	9,45	920	0,62	MF+M00910-24	
H09046051*	51	- 32	2"			62,2	2,45	33	470	132	1910	300	11,81	1140	0,77	MF+M00910-32	

### CONTINUOUS SERVICE TEMPERATURE RANGE

-40 °F / 257 °F  
-40 °C / 125 °C

### TUBE

Oil resistant synthetic rubber

### REINFORCEMENT

Two high resistance textile braids

### COVER

Environment resistant synthetic rubber

### APPLICABLE SPECS

EN 854 3TE; ISO 4079 3TE

### TYPE APPROVALS

DNV-GL; CU-TR

## HYDROPLAST

INTEGRATED, RELIABLE HOSE ASSEMBLY



### KEY FEATURES

- High flexibility
- Tight Bend Radius
- Excellent abrasion resistance

### APPLICATIONS & FLUIDS

- Hydraulics: medium pressure hydraulic applications, hoisting, hydraulic transmission
- Mineral and biological oils, ASTM 1, ASTM 3, polyglycol based oils, water, water oil emulsions

### TECHNICAL DATA

PART. REF.	HOSE SIZE			R.O.D.		O.D.		MAX W.P.		BURST		MIN.BEND		WEIGHT		FITTINGS	
	DN	dash	inch	mm	inch	mm	inch	bar	psi	bar	psi	mm	inch	g/m	lb/ft	Std1	Std2
H30010005*	5	- 3	3/16"			10,2	0,40	210	3040	840	12180	35	1,38	80	0,05	MF+M00820-03	
H30010006*	6	- 4	1/4"			12,0	0,47	192	2780	770	11160	50	1,97	95	0,06	MF+M00830-04	
H30010008*	8	- 5	5/16"			14,3	0,56	187	2710	750	10870	55	2,17	135	0,09	MF+M00830-05	
H30010010*	10	- 6	3/8"			16,3	0,64	175	2530	700	10150	75	2,95	165	0,11	MF+M00820-06	
H30010012*	12	- 8	1/2"			20,3	0,80	140	2030	560	8120	95	3,74	225	0,15	MF+M00820-08	

### CONTINUOUS SERVICE TEMPERATURE RANGE

-40 °F / 212 °F  
-40 °C / 100 °C

### MAX OPERATING TEMPERATURE

100 °C, 212 °F

### TUBE

Oil resistant thermoplastic elastomer

### REINFORCEMENT

Two polyester braids

### COVER

Thermoplastic elastomer with high ozone and abrasion resistance

### APPLICABLE SPECS

EN 855 R7; SAE 100R7

### TYPE APPROVALS

CU-TR

## HYDROTWIN

INTEGRATED, RELIABLE HOSE ASSEMBLY

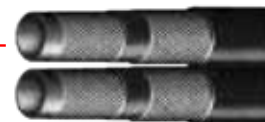

### KEY FEATURES

- High flexibility
- Tight Bend Radius
- Excellent abrasion resistance
- Twin version for easy mounting in OEMs lines

### APPLICATIONS & FLUIDS



- Hydraulics: medium pressure hydraulic applications, hoisting, hydraulic transmission
- Mineral and biological oils, ASTM 1, ASTM 3, polyglycol based oils, water, water oil emulsions

### TECHNICAL DATA

PART. REF.	HOSE SIZE			R.O.D.		O.D.		MAX W.P.		BURST		MIN.BEND		WEIGHT		FITTINGS	
	DN	dash	inch	mm	inch	mm	inch	bar	psi	bar	psi	mm	inch	g/m	lb/ft	Std1	Std2
H30011005*	5	- 3	3/16"			10,2	0,40	210	3040	840	12180	35	1,38	160	0,11	MF+M00820-03	
H30011006*	6	- 4	1/4"			12,0	0,47	192	2780	770	11160	50	1,97	222	0,15	MF+M00830-04	
H30011008*	8	- 5	5/16"			14,3	0,56	187	2710	750	10870	55	2,17	290	0,19	MF+M00830-05	
H30011010*	10	- 6	3/8"			16,3	0,64	175	2530	700	10150	75	2,95	330	0,22	MF+M00820-06	
H30011012*	12	- 8	1/2"			20,3	0,80	140	2030	560	8120	95	3,74	450	0,30	MF+M00820-08	

#### CONTINUOUS SERVICE TEMPERATURE RANGE

-40 °F / 212 °F  
-40 °C / 100 °C

#### MAX OPERATING TEMPERATURE

100 °C, 212 °F

#### TUBE

Oil resistant thermoplastic elastomer

#### REINFORCEMENT

Two polyester braids

#### COVER

Thermoplastic elastomer with high ozone and abrasion resistance

#### APPLICABLE SPECS

EN 855 R7; SAE 100R7

#### TYPE APPROVALS

CU-TR

**ROCKMASTER/1SN**

ABRASION, WEATHER &amp; HEAT RESISTANCE

**KEY FEATURES**

- Superior abrasion resistance
- High ozone and weather resistance
- Flame resistance to a wide range of specs.
- Antistatic and antitoxic cover

**APPLICATIONS & FLUIDS**

- Hydraulics: low-medium pressure lines, return lines, in severe environmental conditions, specific installations with tough abrasion conditions, marine applications, underground and open pit mining
- Mineral oils, vegetable and rape seed oils, glycol and polyglycol based oils, synthetic ester based oils, oils in aqueous emulsion, water

**TECHNICAL DATA**

PART. REF.	HOSE SIZE			R.O.D.		O.D.		MAX W.P.		BURST		MIN.BEND		WEIGHT		FITTINGS	
	DN	dash	inch	mm	inch	mm	inch	bar	psi	bar	psi	mm	inch	g/m	lb/ft	Std1	Std2
H01007006*	6	- 4	1/4"	11,0	0,43	13,0	0,51	225	3260	1000	14500	100	3,94	215	0,14	MF+M03400-04	OPF-04
H01007008*	8	- 5	5/16"	12,6	0,50	14,6	0,57	215	3110	950	13770	114	4,49	260	0,17	MF+M03400-05	OPF-05
H01007010*	10	- 6	3/8"	15,0	0,59	17,0	0,67	180	2610	800	11600	127	5,00	320	0,22	MF+M03400-06	OPF-06
H01007012*	12	- 8	1/2"	18,1	0,71	20,1	0,79	160	2320	680	9860	178	7,01	400	0,27	MF+M03400-08	OPF-08
H01007016*	16	- 10	5/8"	21,3	0,84	23,3	0,92	130	1880	600	8700	200	7,87	480	0,32	MF+M03400-10	OPF-10
H01007019*	19	- 12	3/4"	25,3	1,00	27,3	1,07	105	1520	500	7250	240	9,45	600	0,40	MF+M03400-12	OPF-12
H01007025*	25	- 16	1"	33,1	1,30	35,1	1,38	90	1300	360	5220	300	11,81	910	0,61	MF+M03400-16	OPF-16
H01007032*	31	- 20	1.1/4"	40,6	1,60	43,3	1,70	65	940	260	3770	419	16,50	1243	0,84	MF+M03400-20	OPK-20
H01007040*	38	- 24	1.1/2"	47,0	1,85	49,7	1,96	50	720	260	3770	500	19,69	1450	0,97	MF+M03400-24	OPK-24
H01007051*	51	- 32	2"	60,4	2,38	63,1	2,48	40	580	250	3620	630	24,80	2050	1,38	MF+M03400-32	OPK-32
H01007060*	60	- 38	2.3/8"	68,8	2,71	71,5	2,81	50	720	200	2900	650	25,59	2190	1,47	MF+M03400-38	

**CONTINUOUS SERVICE TEMPERATURE RANGE**

-40 °F / 212 °F  
-40 °C / 100 °C

**MAX OPERATING TEMPERATURE**

125 °C, 257 °F

**TUBE**

Oil resistant synthetic rubber

**REINFORCEMENT**

One high tensile steel braid

**COVER**

Synthetic rubber with high ozone, weather and heat resistance

**APPLICABLE SPECS**

Exceed EN 853 1SN; SAE 100 R1AT; ISO 1436 1SN/R1AT

**TYPE APPROVALS**

ABS; BV; DNV-GL; DNV-GL MED; FRAS; CU-TR; MSHA; LR; NK; MA

**ROCKMASTER/2SN**

ABRASION, WEATHER &amp; HEAT RESISTANCE

**KEY FEATURES**

- Superior abrasion resistance
- High ozone and weather resistance
- Flame resistance to a wide range of specs.
- Antistatic and antitoxic cover
- Over standard pressure resistance

**APPLICATIONS & FLUIDS**

- Hydraulics: medium-high pressure lines in severe environmental conditions, specific installations with tough abrasion conditions, marine applications, underground and open pit mining
- Mineral oils, vegetable and rape seed oils, glycol and polyglycol based oils, synthetic ester based oils, oils in aqueous emulsion, water

**TECHNICAL DATA**

PART. REF.	HOSE SIZE			R.O.D.		O.D.		MAX W.P.		BURST		MIN.BEND		WEIGHT		FITTINGS	
	DN	dash	inch	mm	inch	mm	inch	bar	psi	bar	psi	mm	inch	g/m	lb/ft	Std1	Std2
H01038006*	6	- 4	1/4"	12,7	0,50	14,7	0,58	400	5800	1750	25380	50	1,97	365	0,25	MF+M03400-04	OPF-04
H01038008*	8	- 5	5/16"	14,3	0,56	16,3	0,64	350	5070	1480	21460	60	2,36	405	0,27	MF+M03400-05	OPF-05
H01038010*	10	- 6	3/8"	16,7	0,66	18,7	0,74	350	5070	1400	20300	70	2,76	530	0,36	MF+M03400-06	OPF-06
H01038012*	12	- 8	1/2"	19,8	0,78	21,8	0,86	350	5070	1400	20300	89	3,50	650	0,44	MF+M03400-08	OPF-08
H01038016*	16	- 10	5/8"	23,0	0,91	25,0	0,98	250	3620	1020	14790	100	3,94	720	0,48	MF+M03400-10	OPF-10
H01038019*	19	- 12	3/4"	27,0	1,06	29,0	1,14	215	3110	900	13050	130	5,12	930	0,62	MF+M03400-12	OPF-12
H01038025*	25	- 16	1"	34,8	1,37	36,8	1,45	175	2530	670	9710	160	6,30	1290	0,87	MF+M03400-16	OPF-16
H01038032*	31	- 20	1.1/4"	44,3	1,74	47,0	1,85	140	2030	600	8700	419	16,50	1930	1,30	MF+M03400-20	OPK-20
H01038040*	38	- 24	1.1/2"	50,7	2,00	53,4	2,10	100	1450	500	7250	500	19,69	2262	1,52	MF+M03400-24	OPK-24
H01038051*	51	- 32	2"	63,5	2,50	66,2	2,61	90	1300	420	6090	630	24,80	2880	1,94	MF+M03400-32	OPK-32
H01038060*	60	- 38	2.3/8"	68,8	2,71	71,5	2,81	90	1300	360	5220	650	25,59	2670	1,79	MF+M03400-38	

**CONTINUOUS SERVICE TEMPERATURE RANGE**

-40 °F / 212 °F  
-40 °C / 100 °C

**MAX OPERATING TEMPERATURE**

125 °C, 257 °F

**TUBE**

Oil resistant synthetic rubber

**REINFORCEMENT**

Two high tensile steel braids

**COVER**

Synthetic rubber with high ozone, weather and heat resistance

**APPLICABLE SPECS**

Exceed EN 853 2SN; SAE 100 R2AT; ISO 1436 2SN/R2AT

**TYPE APPROVALS**

ABS; BV; DNV-GL; DNV-GL MED; LR; FRAS; CU-TR; MSHA; RINA ; B; NK; MA; DIN 5510-2



## ROCKMASTER/2ST

ABRASION, WEATHER & HEAT RESISTANCE



### KEY FEATURES

- High robustness of the cover for mining applications and tough handling
- Superior abrasion resistance
- High ozone and weather resistance
- Flame resistance to a wide range of specs.
- Antistatic and antitoxic cover
- Over standard pressure resistance

### APPLICATIONS & FLUIDS



- Hydraulics: medium-high pressure lines in severe environmental conditions, specific installations with tough abrasion conditions, marine applications, underground and open pit mining
- Mineral oils, vegetable and rape seed oils, glycol and polyglycol based oils, synthetic ester based oils, oils in aqueous emulsion, water

### TECHNICAL DATA

PART. REF.	HOSE SIZE			R.O.D.		O.D.		MAX W.P.		BURST		MIN. BEND		WEIGHT		FITTINGS	
	DN	dash	inch	mm	inch	mm	inch	bar	psi	bar	psi	mm	inch	g/m	lb/ft	Std1	Std2
H01035005*	5	- 3	3/16"	11,3	0,44	15,6	0,61	415	6010	2000	29000	89	3,50	385	0,26	MF+M00910-03	
H01035006*	6	- 4	1/4"	12,7	0,50	17,2	0,68	400	5800	1750	25380	100	3,94	450	0,30	MF+M00910-04	
H01035008*	8	- 5	5/16"	14,3	0,56	18,9	0,74	350	5070	1480	21460	114	4,49	500	0,34	MF+M00910-05	
H01035010*	10	- 6	3/8"	16,7	0,66	21,3	0,84	350	5070	1400	20300	127	5,00	640	0,43	MF+M00910-06	
H01035012*	12	- 8	1/2"	19,8	0,78	24,5	0,96	350	5070	1400	20300	178	7,01	790	0,53	MF+M00910-08	
H01035016*	16	- 10	5/8"	23,0	0,91	27,7	1,09	250	3620	1020	14790	200	7,87	870	0,58	MF+M00910-10	
H01035019*	19	- 12	3/4"	27,0	1,06	31,6	1,24	215	3110	900	13050	240	9,45	1100	0,74	MF+M00920-12	
H01035025*	25	- 16	1"	34,8	1,37	39,5	1,56	175	2530	670	9710	300	11,81	1510	1,01	MF+M00930-16	
H01035032*	31	- 20	1.1/4"	44,3	1,74	50,6	1,99	140	2030	600	8700	419	16,50	2310	1,55	MF+M00920-20	
H01035040*	38	- 24	1.1/2"	50,7	2,00	57,0	2,24	100	1450	500	7250	500	19,69	2683	1,80	MF+M00910-24	
H01035051*	51	- 32	2"	63,5	2,50	69,8	2,75	90	1300	420	6090	630	24,80	3410	2,29	MF+M00910-32	

#### CONTINUOUS SERVICE TEMPERATURE RANGE

-40 °F / 212 °F  
-40 °C / 100 °C

#### MAX OPERATING TEMPERATURE

125 °C, 257 °F

#### TUBE

Oil resistant synthetic rubber

#### REINFORCEMENT

Two high tensile steel braids

#### COVER

Synthetic rubber with high ozone, weather and heat resistance

#### APPLICABLE SPECS

Exceed EN 853 2ST; SAE 100 R2A; ISO 1436 2ST/R2A

#### TYPE APPROVALS

BV; CU-TR; LR; B; MSHA; FRAS

**ROCKMASTER/2 PLUS**

ABRASION, WEATHER &amp; HEAT RESISTANCE

**KEY FEATURES**

- Superior pressure rating
- Superior abrasion resistance
- High ozone and weather resistance
- Flame resistance to a wide range of specs.
- Antistatic and antitoxic cover
- Robustness thanks to skive fittings solution

**APPLICATIONS & FLUIDS**

- Hydraulics: high pressure lines with installation constraints in severe environmental conditions, specific installations with tough abrasion conditions, marine applications, underground and open pit mining
- Mineral oils, vegetable and rape seed oils, glycol and polyglycol based oils, synthetic ester based oils, oils in aqueous emulsion, water

**TECHNICAL DATA**

PART. REF.	HOSE SIZE			R.O.D.		O.D.		MAX W.P.		BURST		MIN.BEND		WEIGHT		FITTINGS	
	DN	dash	inch	mm	inch	mm	inch	bar	psi	bar	psi	mm	inch	g/m	lb/ft	Std1	Std2
H01101006*	6	- 4	1/4"	11,3	0,44	13,1	0,52	450	6520	1800	26100	45	1,77	275	0,18	MF+M03400-04	
H01101010*	10	- 6	3/8"	16,7	0,66	18,5	0,73	400	5800	1600	23200	127	5,00	520	0,35	MF+M00910-06	
H01101012*	12	- 8	1/2"	20,1	0,79	22,1	0,87	362	5250	1450	21030	150	5,91	700	0,47	MF+M00910-08	
H01101016*	16	- 10	5/8"	23,2	0,91	25,2	0,99	340	4930	1360	19720	200	7,87	860	0,58	MF+M00910-10	
H01101019*	19	- 12	3/4"	27,1	1,07	29,3	1,15	310	4490	1240	17980	230	9,06	1060	0,71	MF+M00920-12	OPK-12
H01101025*	25	- 16	1"	35,1	1,38	37,8	1,49	240	3480	960	13920	300	11,81	1570	1,06	MF+M00930-16	OPK-16
H01101032*	31	- 20	1.1/4"	44,5	1,75	47,2	1,86	175	2530	700	10150	380	14,96	2120	1,42	MF+M00920-20	OPK-20
H01101038*	38	- 24	1.1/2"	51,0	2,01	53,7	2,11	146	2110	584	8470	450	17,72	2460	1,65	MF+M00910-24	
H01101051*	51	- 32	2"	62,8	2,47	65,5	2,58	130	1880	530	7680	600	23,62	3090	2,08	MF+M00910-32	
H01101076*	76	- 48	3"	87,8	3,46	91,4	3,60	70	1010	280	4060	500	19,69	4290	2,88	MF+M03400-48	

**CONTINUOUS SERVICE TEMPERATURE RANGE**

-40 °F / 212 °F  
-40 °C / 100 °C

**MAX OPERATING TEMPERATURE**

125 °C, 257 °F

**TUBE**

Oil resistant synthetic rubber

**REINFORCEMENT**

Two high tensile steel braids

**COVER**

Synthetic rubber with high ozone, weather and heat resistance

**APPLICABLE SPECS**

MANULI® Design: Exceed ISO 1436-2SN; EN 853-2SN; SAE J517 type 100R2AT.  
Performance BCS 174; ISO 6805 type 4

**TYPE APPROVALS**

BV; DNV-GL; CU-TR; LR; MA (except DN 76); MSHA; FRAS

## ROCKMASTER/1SC

ABRASION, WEATHER & HEAT RESISTANCE



### KEY FEATURES

- Compact and flexible one wire braid hose line
- High temperature resistance for the most severe service and OEM applications
- Working pressure exceeds 1SC standards
- Superior protection with ROCKMASTER® cover compound
- High ozone and weather resistance
- Flame resistance to a wide range of specs.
- Antistatic and antitoxic cover
- Vacuum resistance with SAE 100 R4 performance approved on sizes up to DN 31

### APPLICATIONS & FLUIDS



- Hydraulics: low-medium pressure lines with installation constraints in severe environmental conditions, specific installations with tough abrasion conditions, marine applications, underground and open pit mining
- Mineral oils, vegetable and rape seed oils, glycol and polyglycol based oils, synthetic ester based oils, oils in aqueous emulsion, water

### TECHNICAL DATA

PART. REF.	HOSE SIZE			R.O.D.		O.D.		MAX W.P.		BURST		MIN. BEND		WEIGHT		FITTINGS	
	DN	dash	inch	mm	inch	mm	inch	bar	psi	bar	psi	mm	inch	g/m	lb/ft	Std1	Std2
H01108006*	6	- 4	1/4"	10,2	0,40	12,0	0,47	260	3770	1050	15220	50	1,97	180	0,12	MF+M00120-04	
H01108008*	8	- 5	5/16"	11,5	0,45	13,6	0,54	250	3620	1000	14500	55	2,17	210	0,14	MF+M00120-05	
H01108010*	10	- 6	3/8"	13,6	0,54	15,5	0,61	225	3260	900	13050	60	2,36	255	0,17	MF+M00120-06	
H01108012*	12	- 8	1/2"	17,3	0,68	19,1	0,75	190	2750	760	11020	70	2,76	355	0,24	MF+M00820-08	
H01108016*	16	- 10	5/8"	20,6	0,81	22,4	0,88	150	2170	600	8700	90	3,54	430	0,29	MF+M00820-10	
H01108019*	19	- 12	3/4"	23,9	0,94	25,9	1,02	150	2170	600	8700	100	3,94	520	0,35	MF+M00820-12	
H01108025*	25	- 16	1"	31,3	1,23	33,1	1,30	110	1590	440	6380	160	6,30	730	0,49	MF+M00820-16	
H01108031*	31	- 20	1.1/4"	38,4	1,51	40,9	1,61	75	1080	300	4350	210	8,27	1040	0,70	MF+M00820-20	
H01108038*	38	- 24	1.1/2"	45,0	1,77	47,5	1,87	50	720	200	2900	300	11,81	1170	0,79	MF+M00820-24	
H01108051*	51	- 32	2"	58,0	2,28	60,5	2,38	50	720	200	2900	400	15,75	1560	1,05	MF+M00820-32	
H01108063*	63	- 40	2.1/2"	70,5	2,78	73,0	2,87	50	720	200	2900	760	29,92	2090	1,40	MF+M03400-40	

#### CONTINUOUS SERVICE TEMPERATURE RANGE

-40 °F / 250 °F  
-40 °C / 121 °C

#### TUBE

Oil resistant synthetic rubber

#### REINFORCEMENT

One high tensile steel braid

#### COVER

Synthetic rubber with high ozone, weather and heat resistance

#### APPLICABLE SPECS

Exceed EN 857 1SC; ISO 11237 1SC

#### TYPE APPROVALS

CU-TR; LR; MSHA; FRAS

## ROCKMASTER/2SC

ABRASION, WEATHER & HEAT RESISTANCE



### KEY FEATURES

- Compactness and flexibility
- Superior abrasion resistance
- High ozone and weather resistance
- Flame resistance to a wide range of specs.
- Antistatic and antitoxic cover
- Working pressure improvement
- Range extension to DN 76
- Vacuum resistance with SAE 100 R4 performance approved on sizes up to DN 76

### APPLICATIONS & FLUIDS



- Hydraulics: medium-high pressure lines with installation constraints in severe environmental conditions, specific installations with tough abrasion conditions, marine applications, underground and open pit mining, return and suction lines
- Mineral oils, vegetable and rape seed oils, glycol and polyglycol based oils, synthetic ester based oils, oils in aqueous emulsion, water

### TECHNICAL DATA

PART. REF.	HOSE SIZE		R.O.D.		O.D.		MAX W.P.		BURST		MIN.BEND		WEIGHT		FITTINGS		
	DN	dash	inch	mm	inch	mm	inch	bar	psi	bar	psi	mm	inch	g/m	lb/ft	Std1	Std2
H01030005*	5	- 3	3/16"	9,7	0,38	11,5	0,45	420	6090	2000	29000	40	1,57	220	0,15	MF+M03400-03	OPF-03
H01030006*	6	- 4	1/4"	11,3	0,44	13,1	0,52	400	5800	1850	26830	45	1,77	275	0,18	MF+M03400-04	OPF-04
H01030008*	8	- 5	5/16"	12,9	0,51	14,7	0,58	350	5070	1700	24650	55	2,17	325	0,22	MF+M03400-05	OPF-05
H01030010*	10	- 6	3/8"	15,0	0,59	16,8	0,66	330	4780	1500	21750	65	2,56	390	0,26	MF+M03400-06	OPF-06
H01030012*	12	- 8	1/2"	18,5	0,73	20,3	0,80	275	3980	1220	17690	80	3,15	500	0,34	MF+M03400-08	OPF-08
H01030016*	16	- 10	5/8"	21,8	0,86	23,6	0,93	250	3620	1050	15220	90	3,54	620	0,42	MF+M03400-10	OPF-10
H01030019*	19	- 12	3/4"	25,6	1,01	27,6	1,09	245	3550	980	14210	120	4,72	790	0,53	MF+M03400-12	OPF-12
H01030025*	25	- 16	1"	33,0	1,30	35,2	1,39	210	3040	840	12180	150	5,91	1180	0,79	MF+M03400-16	OPF-16
H01030031*	31	- 20	1.1/4"	41,1	1,62	43,6	1,72	140	2030	560	8120	250	9,84	1550	1,04	MF+M03400-20	OPK-20
H01030038*	38	- 24	1.1/2"	47,7	1,88	50,7	2,00	100	1450	400	5800	300	11,81	1880	1,26	MF+M03400-24	OPK-24
H01030051*	51	- 32	2"	60,4	2,38	63,4	2,50	90	1300	360	5220	400	15,75	2430	1,63	MF+M03400-32	OPK-32
H01030063*	63	- 40	2.1/2"	73,0	2,87	76,0	2,99	70	1010	300	4350	760	29,92	2900	1,95	MF+M03400-40	
H01030076*	76	- 48	3"	87,8	3,46	90,5	3,56	45	650	180	2610	900	35,43	3120	2,10	MF+M03400-48	

#### CONTINUOUS SERVICE TEMPERATURE RANGE

-40 °F / 212 °F  
-40 °C / 100 °C

#### MAX OPERATING TEMPERATURE

125 °C, 257 °F

#### TUBE

Oil resistant synthetic rubber

#### REINFORCEMENT

Two high tensile steel braids

#### COVER

Synthetic rubber with high ozone, weather and heat resistance

#### APPLICABLE SPECS

Exceed EN 857 2SC; ISO 11237 2SC; SAE 100 R16. In addition: DN 25 SAE 100 R17; ISO 11237 R17

#### TYPE APPROVALS

ABS; BV; DNV-GL; CU-TR; LR; MA; MSHA; RINA; B; FRAS; CCS

## ROCKMASTER/4SP

ABRASION, WEATHER & HEAT RESISTANCE



### KEY FEATURES

- Validated for high fatigue resistance
- Superior abrasion resistance
- High ozone and weather resistance
- Flame resistance to a wide range of specs.
- Antistatic and antitoxic cover
- Upgraded temperature resistance
- BIO biological and mineral oils compatibility

### APPLICATIONS & FLUIDS



- Hydraulics: very high pressure power lines in severe environmental conditions, specific installations with tough abrasion conditions, marine applications, underground and open pit mining
- Mineral oils, vegetable oils and synthetic ester based oils (up to 100°C/212°F), glycols and polyglycols, mineral oils in aqueous emulsion, water

### TECHNICAL DATA

PART. REF.	HOSE SIZE			R.O.D.		O.D.		MAX W.P.		BURST		MIN. BEND		WEIGHT		FITTINGS	
	DN	dash	inch	mm	inch	mm	inch	bar	psi	bar	psi	mm	inch	g/m	lb/ft	Std1	Std2
H10008006*	6	- 4	1/4"	14,7	0,58	17,6	0,69	485	7030	2400	34800	125	4,92	590	0,40	MF+M00910-04	
H10008010*	10	- 6	3/8"	17,6	0,69	21,0	0,83	450	6520	2000	29000	125	4,92	740	0,50	MF+M00910-06	
H10008012*	12	- 8	1/2"	20,3	0,80	24,2	0,95	420	6090	1750	25380	175	6,89	880	0,59	MF+M00910-08	
H10008016*	16	- 10	5/8"	23,7	0,93	27,6	1,09	380	5510	1600	23200	200	7,87	1080	0,73	MF+M00910-10	
H10008019*	19	- 12	3/4"	28,2	1,11	31,7	1,25	380	5510	1600	23200	240	9,45	1450	0,97	MF+M00920-12	SP+M05400-12
H10008025*	25	- 16	1"	35,0	1,38	39,0	1,54	320	4640	1400	20300	340	13,39	1880	1,26	MF+M00930-16	SP+M05400-16
H10008032*	31	- 20	1.1/4"	46,1	1,81	49,7	1,96	210	3040	1250	18120	460	18,11	2990	2,01	MF+M00920-20	SP+M05500-20
H10008038*	38	- 24	1.1/2"	52,4	2,06	56,1	2,21	185	2680	1000	14500	560	22,05	3500	2,35	MF+M00910-24	SP+M05500-24
H10008051*	51	- 32	2"	65,4	2,57	69,0	2,72	175	2530	1000	14500	660	25,98	5010	3,37	MF+M00910-32	SP+M05400-32

#### CONTINUOUS SERVICE TEMPERATURE RANGE

-40 °F / 250 °F  
-40 °C / 121 °C

#### MAX OPERATING TEMPERATURE

125 °C, 257 °F

#### TUBE

Oil resistant synthetic rubber

#### REINFORCEMENT

Four high tensile steel spirals

#### COVER

Synthetic rubber with high ozone, weather and heat resistance

#### APPLICABLE SPECS

Exceed EN 856 4SP; ISO 3862 4SP; DN 16 & 19: thin cover style, exceeding performance EN 856 4SP and ISO 3862 4SP

#### TYPE APPROVALS

ABS; DNV-GL; DNV-GL (MED); BV; FRAS; CU-TR; MA; MSHA; RINA; B; LR; NK; DB (EN 45545-2)



#### Remarks:

If service temperature is lower than 212°F/100°C, Rockmaster/4SP can be used with reduced Min. Bend Radius for small sizes (DN6 100mm, DN10 110mm, DN12 120mm, DN16 140mm, DN19 170mm).

## ROCKMASTER/4SH

ABRASION, WEATHER & HEAT RESISTANCE



### KEY FEATURES

- Validated for high fatigue resistance
- Superior abrasion resistance
- High ozone and weather resistance
- Flame resistance to a wide range of specs.
- Antistatic and antitoxic cover
- Upgraded temperature resistance
- BIO biological and mineral oils compatibility

### APPLICATIONS & FLUIDS



- Hydraulics: very high pressure power lines in severe environmental conditions, specific installations with tough abrasion conditions, marine applications, underground and open pit mining
- Mineral oils, vegetable oils and synthetic ester based oils (up to 100°C/212°F), glycols and polyglycols, mineral oils in aqueous emulsion, water

### TECHNICAL DATA

PART. REF.	HOSE SIZE			R.O.D.		O.D.		MAX W.P.		BURST		MIN. BEND		WEIGHT		FITTINGS	
	DN	dash	inch	mm	inch	mm	inch	bar	psi	bar	psi	mm	inch	g/m	lb/ft	Std1	Std2
H10044016*	16	- 10	5/8"	25,5	1,00	28,5	1,12	450	6520	1850	26830	180	7,09	1290	0,87	IP+M01500-10	
H10044019*	19	- 12	3/4"	28,2	1,11	31,9	1,26	420	6090	1750	25380	210	8,27	1500	1,01	IP+M01500-12	SP+M05400-12
H10044025*	25	- 16	1"	35,1	1,38	38,1	1,50	385	5580	1750	25380	220	8,66	2040	1,37	IP+M01500-16	SP+M05400-16
H10044032*	31	- 20	1.1/4"	42,2	1,66	45,0	1,77	350	5070	1400	20300	420	16,54	2410	1,62	IP+M01500-20	SP+M05400-20
H10044038*	38	- 24	1.1/2"	49,1	1,93	53,1	2,09	300	4350	1250	18120	560	22,05	3170	2,13	IP+M01500-24	SP+M05400-24
H10044051*	51	- 32	2"	63,5	2,50	67,5	2,66	250	3620	1000	14500	700	27,56	4460	3,00	IP+M01500-32	SP+M05400-32

#### CONTINUOUS SERVICE TEMPERATURE RANGE

-40 °F / 250 °F  
-40 °C / 121 °C

#### MAX OPERATING TEMPERATURE

125 °C, 257 °F

#### TUBE

Oil resistant synthetic rubber

#### REINFORCEMENT

Four high tensile steel spirals

#### COVER

Synthetic rubber with high ozone, weather and heat resistance

#### APPLICABLE SPECS

Exceed EN 856 4SH; ISO 3862 4SH

#### TYPE APPROVALS

ABS; DNV-GL; DNV-GL (MED); BV; FRAS; CU-TR; LR; MA; MSHA; B; RINA; NK

## ROCKMASTER/12

ABRASION, WEATHER & HEAT RESISTANCE



### KEY FEATURES

- Validated for high fatigue resistance
- Superior abrasion resistance
- High ozone and weather resistance
- Flame resistance to a wide range of specs.
- Antistatic and antitoxic cover
- BIO biological and mineral oils compatibility

### APPLICATIONS & FLUIDS



- Hydraulics: high pressure power lines in severe environmental conditions, specific installations with tough abrasion conditions, marine applications, underground and open pit mining
- Mineral oils, vegetable oils and synthetic ester based oils (up to 100°C/212°F), glycols and polyglycols, mineral oils in aqueous emulsion, water

### TECHNICAL DATA

PART. REF.	HOSE SIZE			R.O.D.		O.D.		MAX W.P.		BURST		MIN. BEND		WEIGHT		FITTINGS	
	DN	dash	inch	mm	inch	mm	inch	bar	psi	bar	psi	mm	inch	g/m	lb/ft	Std1	Std2
H10031010*	10	- 6	3/8"	17,3	0,68	20,0	0,79	280	4060	1600	23200	100	3,94	620	0,42	MF+M00910-06	OPK-06
H10031012*	12	- 8	1/2"	20,4	0,80	23,5	0,93	280	4060	1350	19580	125	4,92	760	0,51	MF+M00910-08	OPK-08
H10031016*	16	- 10	5/8"	24,4	0,96	27,1	1,07	280	4060	1300	18850	140	5,51	990	0,67	MF+M00910-10	OPK-10
H10031019*	19	- 12	3/4"	27,4	1,08	30,4	1,20	280	4060	1300	18850	150	5,91	1160	0,78	MF+M00920-12	OPK-12
H10031025*	25	- 16	1"	35,0	1,38	37,6	1,48	280	4060	1150	16670	225	8,86	1740	1,17	MF+M00930-16	OPK-16
H10031A32*	31	- 20	1.1/4"	43,1	1,70	45,9	1,81	210	3040	1000	14500	250	9,84	2280	1,53	MF+M00920-20	OPK-20
H10031040*	38	- 24	1.1/2"	50,0	1,97	53,3	2,10	175	2530	1000	14500	500	19,69	3130	2,10	MF+M00910-24	OPK-24
H10031051*	51	- 32	2"	63,6	2,50	66,7	2,63	175	2530	800	11600	630	24,80	4440	2,98	MF+M00910-32	OPK-32

### CONTINUOUS SERVICE TEMPERATURE RANGE

-40 °F / 250 °F  
-40 °C / 121 °C

### MAX OPERATING TEMPERATURE

125 °C, 257 °F

### TUBE

Oil resistant synthetic rubber

### REINFORCEMENT

Four high tensile steel spirals

### COVER

Synthetic rubber with high ozone, weather and heat resistance

### APPLICABLE SPECS

Exceed EN 856 R12; SAE 100 R12; ISO 3862 R12

### TYPE APPROVALS

ABS; BV; BV (MED); FRAS; CU-TR; LR; MA; MSHA; NK

## ROCKMASTER/13

ABRASION, WEATHER & HEAT RESISTANCE



### KEY FEATURES

- Validated for high fatigue resistance
- Superior abrasion resistance
- High ozone and weather resistance
- Flame resistance to a wide range of specs.
- Antistatic and antitoxic cover
- BIO biological and mineral oils compatibility

### APPLICATIONS & FLUIDS

- **Hydraulics:** heavy duty power lines, hydrostatic transmissions, severe environmental conditions, specific installations with tough abrasion conditions, marine applications, underground and open pit mining
- Mineral oils, vegetable oils and synthetic ester based oils (up to 100°C/212°F), glycols and polyglycols, mineral oils in aqueous emulsion, water

### TECHNICAL DATA

PART. REF.	HOSE SIZE			R.O.D.		O.D.		MAX W.P.		BURST		MIN.BEND		WEIGHT		FITTINGS	
	DN	dash	inch	mm	inch	mm	inch	bar	psi	bar	psi	mm	inch	g/m	lb/ft	Std1	Std2
H10035A06*	6	- 4	1/4"	14,6	0,57	17,6	0,69	690	10000	3250	47130	120	4,72	660	0,44		
H10035A10*	10	- 6	3/8"	17,4	0,69	20,4	0,80	690	10000	2900	42060	150	5,91	830	0,56		
H10035A12*	12	- 8	1/2"	21,5	0,85	24,5	0,96	620	8990	2500	36250	200	7,87	1140	0,77		
H10035019*	19	- 12	3/4"	29,0	1,14	31,8	1,25	350	5070	1950	28280	240	9,45	1630	1,10	IP+M01500-12	SP+M05400-12
H10035025*	25	- 16	1"	36,0	1,42	39,2	1,54	350	5070	1650	23930	300	11,81	2190	1,47	IP+M01500-16	SP+M05400-16
H10035032*	31	- 20	1.1/4"	47,0	1,85	50,0	1,97	350	5070	1500	21750	420	16,54	3600	2,42	IP+M01600-20	SP+M05500-20
H10035040*	38	- 24	1.1/2"	54,6	2,15	57,5	2,26	350	5070	1600	23200	500	19,69	4700	3,16	IP+M01600-24	SP+M05500-24
H10035051*	51	- 32	2"	68,4	2,69	72,0	2,83	350	5070	1500	21750	630	24,80	6800	4,57	IP+M01800-32	SP+M05500-32

#### CONTINUOUS SERVICE TEMPERATURE RANGE

-40 °F / 250 °F  
-40 °C / 121 °C

#### MAX OPERATING TEMPERATURE

125 °C, 257 °F

#### TUBE

Oil resistant synthetic rubber

#### REINFORCEMENT

Four high tensile steel spirals (DN 6÷25). Six high tensile steel spirals (DN 31÷51)

#### COVER

Synthetic rubber with high ozone, weather and heat resistance

#### APPLICABLE SPECS

Exceed EN 856 R13; SAE 100 R13; ISO 3862 R13

#### TYPE APPROVALS

ABS; BV; DNV-GL; BV MED; FRAS; LR; CU-TR; MA; MSHA; RINA; B



## ROCKMASTER/15

ABRASION, WEATHER & HEAT RESISTANCE



### KEY FEATURES

- Validated for high fatigue resistance
- Superior abrasion resistance
- High ozone and weather resistance
- Flame resistance to a wide range of specs.
- Antistatic and antitoxic cover
- BIO biological and mineral oils compatibility

### APPLICATIONS & FLUIDS



- Hydraulics: heavy duty power lines, hydrostatic transmissions, in severe environmental conditions, specific installations with tough abrasion conditions, marine applications, underground and open pit mining
- Mineral oils, vegetable oils and synthetic ester based oils (up to 100°C/212°F), glycols and polyglycols, mineral oils in aqueous emulsion, water

### TECHNICAL DATA

PART. REF.	HOSE SIZE			R.O.D.		O.D.		MAX W.P.		BURST		MIN.BEND		WEIGHT		FITTINGS	
	DN	dash	inch	mm	inch	mm	inch	bar	psi	bar	psi	mm	inch	g/m	lb/ft	Std1	Std2
H10049019*	19	- 12	3/4"	28,2	1,11	31,0	1,22	420	6090	1750	25380	265	10,43	1440	0,97	IP+M01500-12	SP+M05400-12
H10049025*	25	- 16	1"	35,1	1,38	38,1	1,50	420	6090	1750	25380	267	10,51	2040	1,37	IP+M01500-16	SP+M05400-16
H10049A32*	31	- 20	1.1/4"	46,3	1,82	49,5	1,95	420	6090	1680	24360	267	10,51	3660	2,46	IP+M01600-20	SP+M05500-20
H10049040*	38	- 24	1.1/2"	54,6	2,15	57,5	2,26	420	6090	1680	24360	315	12,40	4700	3,16	IP+M01600-24	SP+M05500-24

### CONTINUOUS SERVICE TEMPERATURE RANGE

-40 °F / 250 °F  
-40 °C / 121 °C

### MAX OPERATING TEMPERATURE

125 °C, 257 °F

### TUBE

Oil resistant synthetic rubber

### REINFORCEMENT

Four high tensile steel spirals (DN 19 ÷ 25). Six high tensile steel spirals (DN 31 ÷ 38)

### COVER

Synthetic rubber with high ozone, weather and heat resistance

### APPLICABLE SPECS

Exceed SAE 100 R15; ISO 3862 R15

### TYPE APPROVALS

ABS; BV; BV (MED); DNV-GL; FRAS; CU-TR; LR; MA; MSHA; B

## EQUATOR/1 (BLUE)

EXTREME TEMPERATURE - BLUE VERSION



### KEY FEATURES

- Wide range temperature resistance
- EN/DIN and new SAE pressure rating
- Outstanding ozone resistance
- Superior weather and UV resistance
- High aging resistance

### APPLICATIONS & FLUIDS



- Hydraulics: low-medium pressure lines in extreme temperature conditions (foundries, compressors, hydraulics within engine compartments, etc.)
- Mineral oils, glycols and polyglycols, transmission fluids, air with oil vapours, mineral oils in aqueous emulsion (up to 212°F/100°C)

### TECHNICAL DATA

PART. REF.	HOSE SIZE			R.O.D.		O.D.		MAX W.P.		BURST		MIN.BEND		WEIGHT		FITTINGS	
	DN	dash	inch	mm	inch	mm	inch	bar	psi	bar	psi	mm	inch	g/m	lb/ft	Std1	Std2
H01059006*	6	- 4	1/4"	11,0	0,43	13,4	0,53	225	3260	1000	14500	100	3,94	240	0,16	MF+M00120-04	OPF-04
H01059008*	8	- 5	5/16"	12,6	0,50	15,0	0,59	215	3110	900	13050	114	4,49	285	0,19	MF+M00120-05	
H01059010*	10	- 6	3/8"	15,0	0,59	17,3	0,68	180	2610	800	11600	127	5,00	340	0,23	MF+M00120-06	
H01059012*	12	- 8	1/2"	18,1	0,71	20,5	0,81	160	2320	680	9860	178	7,01	435	0,29	MF+M00120-08	
H01059016*	16	- 10	5/8"	21,3	0,84	23,5	0,93	130	1880	600	8700	200	7,87	510	0,34	MF+M00120-10	
H01059019*	19	- 12	3/4"	25,2	0,99	27,7	1,09	105	1520	500	7250	240	9,45	640	0,43	MF+M00120-12	
H01059025*	25	- 16	1"	33,1	1,30	35,8	1,41	88	1270	360	5220	300	11,81	980	0,66	MF+M00130-16	
H01059032*	31	- 20	1.1/4"	40,6	1,60	43,5	1,71	65	940	345	5000	420	16,54	1300	0,87	MF+M00110-20	OPK-20
H01059038*	38	- 24	1.1/2"	46,9	1,85	50,0	1,97	50	720	290	4200	500	19,69	1540	1,03	MF+M00110-24	OPK-24
H01059051*	51	- 32	2"	60,4	2,38	63,1	2,48	40	580	250	3620	630	24,80	2100	1,41	MF+M00110-32	OPK-32
H01059063*	63	- 40	2.1/2"	72,0	2,83	74,6	2,94	35	500	140	2030	600	23,62	2400	1,61	MF+M03400-40	

#### CONTINUOUS SERVICE TEMPERATURE RANGE

-67 °F / 275 °F  
-55 °C / 135 °C

#### MAX OPERATING TEMPERATURE

150 °C, 300 °F

#### TUBE

Oil resistant synthetic rubber

#### REINFORCEMENT

One high tensile steel braid

#### COVER

Synthetic rubber with high ozone, weather and heat resistance

#### APPLICABLE SPECS

Exceed EN 853 1SN; SAE 100 R1AT; ISO 1436 1SN/R1AT

#### TYPE APPROVALS

ABS; BV; BV MED; DNV-GL; CU-TR; LR; MSHA



#### Remarks:

- Compressed air applications require cover pin-pricking and additional safety devices
- Equator hose is not suitable for high temperature water applications
- Equator hose is not designed and not approved for "air brake" applications on railway and/or mobile equipment.

## EQUATOR/1 (BLACK)

EXTREME TEMPERATURE - BLACK VERSION



### KEY FEATURES

- Wide range temperature resistance
- EN/DIN and new SAE pressure rating
- Outstanding ozone resistance
- Superior weather and UV resistance
- High aging resistance

### APPLICATIONS & FLUIDS



- Hydraulics: low-medium pressure lines in extreme temperature conditions (foundries, compressors, hydraulics within engine compartments, etc.)
- Mineral oils, glycols and polyglycols, transmission fluids, air with oil vapours, mineral oils in aqueous emulsion (up to 212°F/100°C)

### TECHNICAL DATA

PART. REF.	HOSE SIZE			R.O.D.		O.D.		MAX W.P.		BURST		MIN.BEND		WEIGHT		FITTINGS	
	DN	dash	inch	mm	inch	mm	inch	bar	psi	bar	psi	mm	inch	g/m	lb/ft	Std1	Std2
H01058006*	6	- 4	1/4"	11,0	0,43	13,4	0,53	225	3260	1000	14500	100	3,94	240	0,16	MF+M00120-04	OPF-04
H01058008*	8	- 5	5/16"	12,6	0,50	15,0	0,59	215	3110	900	13050	114	4,49	280	0,19	MF+M00120-05	
H01058010*	10	- 6	3/8"	15,0	0,59	17,3	0,68	180	2610	800	11600	127	5,00	335	0,23	MF+M00120-06	
H01058012*	12	- 8	1/2"	18,1	0,71	20,5	0,81	160	2320	680	9860	178	7,01	430	0,29	MF+M00120-08	
H01058016*	16	- 10	5/8"	21,3	0,84	23,5	0,93	130	1880	600	8700	200	7,87	500	0,34	MF+M00120-10	
H01058019*	19	- 12	3/4"	25,2	0,99	27,7	1,09	105	1520	500	7250	240	9,45	640	0,43	MF+M00120-12	
H01058025*	25	- 16	1"	33,1	1,30	35,8	1,41	88	1270	360	5220	300	11,81	970	0,65	MF+M00130-16	
H01058031*	31	- 20	1.1/4"	40,6	1,60	43,5	1,71	65	940	345	5000	420	16,54	1300	0,87	MF+M00110-20	OPK-20
H01058038*	38	- 24	1.1/2"	46,9	1,85	50,0	1,97	50	720	290	4200	500	19,69	1540	1,03	MF+M00110-24	OPK-24
H01058051*	51	- 32	2"	60,4	2,38	63,1	2,48	40	580	250	3620	630	24,80	2100	1,41	MF+M00110-32	OPK-32
H01058063*	63	- 40	2.1/2"	72,0	2,83	74,6	2,94	35	500	140	2030	600	23,62	2400	1,61	MF+M03400-40	

#### CONTINUOUS SERVICE TEMPERATURE RANGE

-67 °F / 275 °F  
-55 °C / 135 °C

#### MAX OPERATING TEMPERATURE

150 °C, 300 °F

#### TUBE

Oil resistant synthetic rubber

#### REINFORCEMENT

One high tensile steel braid

#### COVER

Synthetic rubber with high ozone, weather and heat resistance.

#### APPLICABLE SPECS

Exceed EN 853 1SN; SAE 100 R1AT; ISO 1436 1SN/R1AT

#### TYPE APPROVALS

ABS; DNV-GL; CU-TR; LR; MSHA



#### Remarks:

- Compressed air applications require cover pin-pricking and additional safety devices
- Equator hose is not suitable for high temperature water applications
- Equator hose is not designed and not approved for "air brake" applications on railway and/or mobile equipment.

## EQUATOR/2 (BLUE)

EXTREME TEMPERATURE - BLUE VERSION



### KEY FEATURES

- Wide range temperature resistance
- EN/DIN and new SAE pressure rating
- Outstanding ozone resistance
- Superior weather and UV resistance
- High aging resistance

### APPLICATIONS & FLUIDS



- Hydraulics: medium-high pressure lines in extreme temperature conditions (foundries, compressors, hydraulics within engine compartments, etc.)
- Mineral oils, glycols and polyglycols, transmission fluids, air with oil vapours, mineral oils in aqueous emulsion (up to 212°F/100°C)

### TECHNICAL DATA

PART. REF.	HOSE SIZE			R.O.D.		O.D.		MAX W.P.		BURST		MIN.BEND		WEIGHT		FITTINGS	
	DN	dash	inch	mm	inch	mm	inch	bar	psi	bar	psi	mm	inch	g/m	lb/ft	Std1	Std2
H01061006*	6	- 4	1/4"	12,7	0,50	14,9	0,59	400	5800	1725	25010	100	3,94	395	0,27	MF+M00910-04	OPF-04
H01061008*	8	- 5	5/16"	14,3	0,56	16,5	0,65	350	5070	1480	21460	114	4,49	435	0,29	MF+M00910-05	
H01061010*	10	- 6	3/8"	16,7	0,66	19,0	0,75	330	4780	1400	20300	127	5,00	530	0,36	MF+M00910-06	
H01061012*	12	- 8	1/2"	19,8	0,78	22,0	0,87	275	3980	1200	17400	178	7,01	640	0,43	MF+M00910-08	
H01061016*	16	- 10	5/8"	23,0	0,91	25,2	0,99	250	3620	1020	14790	200	7,87	760	0,51	MF+M00910-10	
H01061019*	19	- 12	3/4"	27,0	1,06	29,0	1,14	215	3110	900	13050	240	9,45	940	0,63	MF+M00920-12	
H01061025*	25	- 16	1"	34,8	1,37	37,0	1,46	175	2530	700	10150	300	11,81	1350	0,91	MF+M00930-16	
H01061032*	31	- 20	1.1/4"	44,3	1,74	47,0	1,85	150	2170	600	8700	420	16,54	2010	1,35	MF+M00920-20	
H01061040*	38	- 24	1.1/2"	50,7	2,00	53,4	2,10	100	1450	410	5940	500	19,69	2250	1,51	MF+M00910-24	OPK-24
H01061051*	51	- 32	2"	63,5	2,50	66,2	2,61	90	1300	370	5360	630	24,80	3080	2,07	MF+M00910-32	OPK-32

#### CONTINUOUS SERVICE TEMPERATURE RANGE

-67 °F / 275 °F  
-55 °C / 135 °C

#### MAX OPERATING TEMPERATURE

150 °C, 300 °F

#### TUBE

Oil resistant synthetic rubber

#### REINFORCEMENT

Two high tensile steel braids

#### COVER

Synthetic rubber with high ozone, weather and heat resistance.

#### APPLICABLE SPECS

Exceed EN 853 2SN; SAE 100 R2AT; ISO 1436 2SN/R2AT

#### TYPE APPROVALS

ABS; BV; BV (MED); DNV-GL; CU-TR; LR; MSHA; DIN 5510-2



#### Remarks:

- Compressed air applications require cover pin-pricking and additional safety devices
- Equator hose is not suitable for high temperature water applications
- Equator hoses are not designed and not approved for "air brake" applications on railway and/or mobile equipment

## EQUATOR/2 (BLACK)

EXTREME TEMPERATURE - BLACK VERSION



### KEY FEATURES

- Wide range temperature resistance
- EN/DIN and new SAE pressure rating
- Outstanding ozone resistance
- Superior weather and UV resistance
- High aging resistance

### APPLICATIONS & FLUIDS



- Hydraulics: medium-high pressure lines in extreme temperature conditions (foundries, compressors, hydraulics within engine compartments, etc.)
- Mineral oils, glycols and polyglycols, transmission fluids, air with oil vapours, mineral oils in aqueous emulsion (up to 212°F/100°C)

### TECHNICAL DATA

PART. REF.	HOSE SIZE			R.O.D.		O.D.		MAX W.P.		BURST		MIN.BEND		WEIGHT		FITTINGS	
	DN	dash	inch	mm	inch	mm	inch	bar	psi	bar	psi	mm	inch	g/m	lb/ft	Std1	Std2
H01060006*	6	- 4	1/4"	12,7	0,50	14,9	0,59	400	5800	1725	25010	100	3,94	390	0,26	MF+M00910-04	OPF-04
H01060008*	8	- 5	5/16"	14,3	0,56	16,5	0,65	350	5070	1480	21460	114	4,49	435	0,29	MF+M00910-05	
H01060010*	10	- 6	3/8"	16,7	0,66	19,0	0,75	330	4780	1400	20300	127	5,00	530	0,36	MF+M00910-06	
H01060012*	12	- 8	1/2"	19,8	0,78	22,0	0,87	275	3980	1200	17400	178	7,01	640	0,43	MF+M00910-08	
H01060016*	16	- 10	5/8"	23,0	0,91	25,2	0,99	250	3620	1020	14790	200	7,87	760	0,51	MF+M00910-10	
H01060019*	19	- 12	3/4"	27,0	1,06	29,0	1,14	215	3110	900	13050	240	9,45	940	0,63	MF+M00920-12	
H01060025*	25	- 16	1"	34,8	1,37	37,0	1,46	175	2530	700	10150	300	11,81	1350	0,91	MF+M00930-16	
H01060031*	31	- 20	1.1/4"	44,3	1,74	47,0	1,85	150	2170	600	8700	420	16,54	2010	1,35	MF+M00920-20	
H01060038*	38	- 24	1.1/2"	50,7	2,00	53,4	2,10	100	1450	410	5940	500	19,69	2250	1,51	MF+M00910-24	OPK-24
H01060051*	51	- 32	2"	63,5	2,50	66,2	2,61	90	1300	370	5360	630	24,80	3080	2,07	MF+M00910-32	OPK-32

#### CONTINUOUS SERVICE TEMPERATURE RANGE

-67 °F / 275 °F  
-55 °C / 135 °C

#### MAX OPERATING TEMPERATURE

150 °C, 300 °F

#### TUBE

Oil resistant synthetic rubber

#### REINFORCEMENT

Two high tensile steel braids

#### COVER

Synthetic rubber with high abrasion, ozone, weather and heat resistance.

#### APPLICABLE SPECS

Exceed EN 853 2SN; SAE 100 R2AT; ISO 1436 2SN/R2AT

#### TYPE APPROVALS

ABS; DNV-GL; CU-TR; LR; MSHA



#### Remarks:

- Compressed air applications require cover pin-pricking and additional safety devices
- Equator hose is not suitable for high temperature water applications
- Equator hoses are not designed and not approved for "air brake" applications on railway and/or mobile equipment

## PILOT

EXTREME LIGHTNESS



### KEY FEATURES

- High temperature working conditions
- ROCKMASTER® cover compound for tough environment, high abrasion, ozone, aging resistance
- Superior lightness and flexibility
- Extreme compact structure
- Approved at 1.000.000 cycles at rated working pressure
- Kink resistant solution for pilot applications

### APPLICATIONS & FLUIDS



- Hydraulics: specifically studied for pilot lines, useful also for low pressure lines with installation constraints. Ideal for severe installations, e.g. for engine compartments and for high temperature applications
- Mineral oils, vegetable and rape seed oils, glycol and polyglycol based oils, synthetic ester based oils, oils in aqueous emulsion, water

### TECHNICAL DATA

PART. REF.	HOSE SIZE			R.O.D.		O.D.		MAX W.P.		BURST		MIN.BEND		WEIGHT		FITTINGS	
	DN	dash	inch	mm	inch	mm	inch	bar	psi	bar	psi	mm	inch	g/m	lb/ft	Std1	Std2
H01015005*	5	- 3	3/16"	8,7	0,34	10,5	0,41	150	2170	600	8700	20	0,79	145	0,10	MF+M03300-03	
H01015A06*	6	- 4	1/4"	9,9	0,39	11,5	0,45	150	2170	600	8700	25	0,98	160	0,11	MF+M03300-04	MN+M02400-04
H01015008*	8	- 5	5/16"	11,5	0,45	13,1	0,52	120	1740	480	6960	30	1,18	185	0,12	MF+M03300-05	MN+M02400-05
H01015010*	10	- 6	3/8"	13,2	0,52	14,8	0,58	100	1450	400	5800	40	1,57	205	0,14	MF+M03300-06	MN+M02400-06
H01015012*	12	- 8	1/2"	16,2	0,64	18,0	0,71	100	1450	400	5800	50	1,97	270	0,18	MF+M00820-08	

#### CONTINUOUS SERVICE TEMPERATURE RANGE

-40 °F / 250 °F  
-40 °C / 121 °C

#### TUBE

Oil resistant synthetic rubber

#### REINFORCEMENT

One high tensile steel braid

#### COVER

Environment resistant synthetic rubber

#### APPLICABLE SPECS

MANULI® Design

#### TYPE APPROVALS

CU-TR; MSHA

## NOZONE/2K

OUTSTANDING OZONE RESISTANCE



### KEY FEATURES

- Outstanding ozone resistance
- Superior weather and UV resistance
- High temperature resistance
- High aging resistance

### APPLICATIONS & FLUIDS



- Hydraulics: medium-high pressure lines with installation constraints and extreme environmental conditions
- Mineral oils, vegetable oils and synthetic ester based oils (up to 100°C/212°F), glycols and polyglycols, mineral oils in aqueous emulsion, water

### TECHNICAL DATA

PART. REF.	HOSE SIZE			R.O.D.		O.D.		MAX W.P.		BURST		MIN.BEND		WEIGHT		FITTINGS	
	DN	dash	inch	mm	inch	mm	inch	bar	psi	bar	psi	mm	inch	g/m	lb/ft	Std1	Std2
H01039006*	6	- 4	1/4"	11,3	0,44	13,1	0,52	400	5800	1850	26830	45	1,77	280	0,19	MF+M03400-04	OPF-04
H01039008*	8	- 5	5/16"	12,9	0,51	14,7	0,58	350	5070	1700	24650	55	2,17	330	0,22	MF+M03400-05	OPF-05
H01039010*	10	- 6	3/8"	15,0	0,59	16,8	0,66	330	4780	1500	21750	65	2,56	395	0,27	MF+M03400-06	OPF-06
H01039012*	12	- 8	1/2"	18,5	0,73	20,3	0,80	275	3980	1220	17690	80	3,15	510	0,34	MF+M03400-08	OPF-08
H01039016*	16	- 10	5/8"	21,8	0,86	23,6	0,93	250	3620	1050	15220	90	3,54	600	0,40	MF+M03400-10	OPF-10
H01039019*	19	- 12	3/4"	25,6	1,01	27,6	1,09	215	3110	920	13340	120	4,72	800	0,54	MF+M03400-12	OPF-12

#### CONTINUOUS SERVICE TEMPERATURE RANGE

-40 °F / 250 °F  
-40 °C / 121 °C

#### MAX OPERATING TEMPERATURE

135 °C, 275 °F

#### TUBE

Oil resistant synthetic rubber

#### REINFORCEMENT

Two high tensile steel braids

#### COVER

Synthetic rubber with high ozone, weather and heat resistance

#### APPLICABLE SPECS

Exceed EN 857 2SC; ISO 11237 2SC

#### TYPE APPROVALS

CU-TR; MSHA

## ETERNITY/2

HIGH SERVICE LIFE AND RELIABILITY



### KEY FEATURES

- The Hi-Performance solution for toughest OEM specifications
- Performance far exceeds EN 857-2SC
- Extended service life and resistance to fatigue
- High temperature and environmental resistance
- Enhanced flex impulse resistance with M00120 skive ferrule

### APPLICATIONS & FLUIDS



- Hydraulics: high pressure lines with installation constraints in severe OEM applications
- Mineral oils, vegetable oils and synthetic ester based oils (up to 100°C/212°F), glycols and polyglycols, mineral oils in aqueous emulsion, water

### TECHNICAL DATA

PART. REF.	HOSE SIZE			R.O.D.		O.D.		MAX W.P.		BURST		MIN.BEND		WEIGHT		FITTINGS	
	DN	dash	inch	mm	inch	mm	inch	bar	psi	bar	psi	mm	inch	g/m	lb/ft	Std1	Std2
H01102006*	6	- 4	1/4"	11,3	0,44	13,1	0,52	450	6520	1800	26100	45	1,77	275	0,18	MF+M00120-04	OPF-04
H01102008*	8	- 5	5/16"	12,9	0,51	14,7	0,58	400	5800	1600	23200	55	2,17	325	0,22	MF+M00120-05	OPF-05
H01102010*	10	- 6	3/8"	15,0	0,59	16,8	0,66	365	5290	1460	21170	65	2,56	390	0,26	MF+M00120-06	OPF-06
H01102A12*	12	- 8	1/2"	18,6	0,73	20,4	0,80	350	5070	1400	20300	80	3,15	560	0,38	MF+M00120-08	OPF-08
H01102016*	16	- 10	5/8"	22,7	0,89	24,7	0,97	300	4350	1200	17400	90	3,54	730	0,49	MF+M00120-10	
H01102019*	19	- 12	3/4"	27,1	1,07	29,3	1,15	300	4350	1200	17400	120	4,72	1070	0,72	MF+M00120-12	
H01102025*	25	- 16	1"	33,7	1,33	35,9	1,41	225	3260	900	13050	160	6,30	1340	0,90	MF+M00130-16	

#### CONTINUOUS SERVICE TEMPERATURE RANGE

-40 °F / 250 °F  
-40 °C / 121 °C

#### MAX OPERATING TEMPERATURE

135 °C, 275 °F

#### TUBE

Oil resistant synthetic rubber

#### REINFORCEMENT

Two high tensile steel braids

#### COVER

Synthetic rubber with high ozone, abrasion and weather resistance

#### APPLICABLE SPECS

Exceed EN 857 2SC; SAE 100R16; ISO 11237 2SC

#### TYPE APPROVALS

ABS; DNV-GL; DNV-GL (MED); CU-TR; FRAS; MSHA



## DIAMONDSPIR

VERY HIGH PRESSURE



### KEY FEATURES

- Very high pressure resistance
- Validated for high fatigue resistance
- Superior abrasion resistance
- High ozone and weather resistance
- Flame resistance to a wide range of specs.
- Antistatic and antitoxic cover
- BIO Biological and mineral oils compatibility

### APPLICATIONS & FLUIDS



- Hydraulics: heavy duty power lines, hydrostatic transmissions, in severe environmental conditions, specific installations with tough abrasion conditions, off-shore applications, underground and open pit mining
- Mineral oils, vegetable oils and synthetic ester based oils (up to 100°C/212°F), glycols and polyglycols, mineral oils in aqueous emulsion, water

### TECHNICAL DATA

PART. REF.	HOSE SIZE			R.O.D.		O.D.		MAX W.P.		BURST		MIN. BEND		WEIGHT		FITTINGS	
	DN	dash	inch	mm	inch	mm	inch	bar	psi	bar	psi	mm	inch	g/m	lb/ft	Std1	Std2
H10018019*	19	- 12	3/4"	29,1	1,15	32,1	1,26	560	8120	2240	32480	280	11,02	1660	1,12	XL+M01750-12	
H10018025*	25	- 16	1"	38,2	1,50	41,2	1,62	560	8120	2240	32480	350	13,78	2910	1,96	XL+M01800-16	
H10018032*	31	- 20	1.1/4"	47,7	1,88	50,9	2,00	525	7610	2100	30450	420	16,54	4210	2,83	XL+M01800-20	
H10018038*	38	- 24	1.1/2"	55,2	2,17	58,7	2,31	475	6880	1900	27550	500	19,69	5230	3,51	XL+M01800-24	
H10018051*	51	- 32	2"	68,4	2,69	71,9	2,83	420	6090	1680	24360	600	23,62	6680	4,49	XL+M01800-32	

#### CONTINUOUS SERVICE TEMPERATURE RANGE

-40 °F / 250 °F  
-40 °C / 121 °C

#### MAX OPERATING TEMPERATURE

125 °C, 257 °F

#### TUBE

Oil resistant synthetic rubber

#### REINFORCEMENT

Six high tensile steel spirals (DN 25÷76). Four high tensile steel spirals (DN 19)

#### COVER

Synthetic rubber with high abrasion, ozone, weather and heat resistance

#### APPLICABLE SPECS

MANULI® Design; Exceed ISO 3862 R15

#### TYPE APPROVALS

ABS; FRAS; CU-TR; MSHA; MA

## SHIELDMASTER/2 PLUS MINE

OUTSTANDING ABRASION RESISTANCE, MSHA APPROVED



### KEY FEATURES

- MSHA approved composite cover for mining applications
- Outstanding abrasion and ozone resistance
- Easy assembling and mounting operations, no protection sleeves are required
- Indelible branding technology
- Reduced bend radius for difficult installations
- Flame retardant and electrical antistaticity cover properties

### APPLICATIONS & FLUIDS



- High pressure hydraulic lines
- High resistance to abrasion conditions, including rubbing among hoses in bunches, alternative to spring guards, ease of cleaning in dusty environments
- For severe mining environments, underground and open pit, long resistance to ozone and weathering, cold temperatures, antistatic and flame retardant properties of the cover
- Mineral oils, vegetable oils and synthetic ester based oils (up to 100°C/212°F), glycols and polyglycols, mineral oils in aqueous emulsion, water

### TECHNICAL DATA

PART. REF.	HOSE SIZE			R.O.D.		O.D.		MAX W.P.		BURST		MIN. BEND		WEIGHT		FITTINGS	
	DN	dash	inch	mm	inch	mm	inch	bar	psi	bar	psi	mm	inch	g/m	lb/ft	Std1	Std2
H01122006*	6	- 4	1/4"	11,3	0,44	12,7	0,50	450	6520	1800	26100	45	1,77	285	0,19	MF+M03400-04	
H01122008*	8	- 5	5/16"	12,9	0,51	14,3	0,56	400	5800	1600	23200	85	3,35	330	0,22	MF+M00120-05	
H01122010*	10	- 6	3/8"	16,7	0,66	18,5	0,73	400	5800	1600	23200	127	5,00	549	0,37	MF+M00910-06	
H01122012*	12	- 8	1/2"	20,1	0,79	22,1	0,87	362	5250	1450	21030	150	5,91	710	0,48	MF+M00910-08	
H01122019*	19	- 12	3/4"	27,1	1,07	29,3	1,15	310	4490	1240	17980	230	9,06	1090	0,73	MF+M00920-12	OPK-12
H01122025*	25	- 16	1"	35,1	1,38	37,8	1,49	240	3480	960	13920	300	11,81	1610	1,08	MF+M00930-16	OPK-16
H01122031*	31	- 20	1.1/4"	44,5	1,75	47,2	1,86	175	2530	700	10150	380	14,96	2170	1,46	MF+M00920-20	OPK-20
H01122038*	38	- 24	1.1/2"	51,0	2,01	53,7	2,11	146	2110	584	8470	450	17,72	2520	1,69	MF+M00910-24	
H01122051*	51	- 32	2"	62,8	2,47	65,5	2,58	130	1880	520	7540	600	23,62	3170	2,13	MF+M00910-32	

#### CONTINUOUS SERVICE TEMPERATURE RANGE

-40 °F / 212 °F  
-40 °C / 100 °C

#### MAX OPERATING TEMPERATURE

125 °C, 257 °F

#### TUBE

Oil resistant synthetic rubber

#### REINFORCEMENT

Two wire braids of high tensile steel wire

#### COVER

Composite bi-layer structure with outstanding abrasion and ozone resistance

#### APPLICABLE SPECS

EN 853 type 2SN; ISO 1436 2SN; SAE J517 100R2AT. Exceed performances of: BCS 174 (British Coal Specification '92); ISO 6805 type 4 (Rubber hoses and hose assemblies for underground mining)

#### TYPE APPROVALS

MSHA; CU-TR



#### Remarks:

Applications with materials projection or winding on low bend radius pulley systems should be field tested before use; high abrasion resistant rubber cover hoses are appropriate in most cases.

## PUSHFIT

### PUSH-ON HOSE



#### KEY FEATURES

- Push-On hose with MF2000® Push-Lock insert type without ferrule
- High aging resistance
- Robust assemblies (clamps recommended in long lasting mission profiles applications)
- High flexibility and easy routing

#### APPLICATIONS & FLUIDS



- Push-on hose for low pressure lines, return lines, drain lines. Used in various industrial applications, stationary and mobile equipment
- Mineral oils, vegetable and rape seed oils, glycol and polyglycol based oils, synthetic ester based oils, oils in aqueous emulsion, water

#### TECHNICAL DATA

PART. REF.	HOSE SIZE			R.O.D.		O.D.		MAX W.P.		BURST		MIN. BEND		WEIGHT		FITTINGS	
	DN	dash	inch	mm	inch	mm	inch	bar	psi	bar	psi	mm	inch	g/m	lb/ft	Std1	Std2
H09066006*	6	- 4	1/4"			12,7	0,50	35	500	140	2030	76	2,99	130	0,09	PL	
H09066008*	8	- 5	5/16"			14,3	0,56	35	500	140	2030	76	2,99	155	0,10	PL	
H09066010*	10	- 6	3/8"			15,8	0,62	35	500	140	2030	76	2,99	175	0,12	PL	
H09066012*	12	- 8	1/2"			19,6	0,77	25	360	100	1450	127	5,00	235	0,16	PL	
H09066016*	16	- 10	5/8"			23,6	0,93	25	360	100	1450	150	5,91	320	0,22	PL	
H09066019*	19	- 12	3/4"			26,2	1,03	21	300	84	1210	180	7,09	340	0,23	PL	
H09066025*	25	- 16	1"			33,0	1,30	14	200	56	810	240	9,45	455	0,31	PL	

#### CONTINUOUS SERVICE TEMPERATURE RANGE

-40 °F / 212 °F  
-40 °C / 100 °C

#### MAX OPERATING TEMPERATURE

121 °C, 250 °F

#### TUBE

Oil resistant synthetic rubber compound

#### REINFORCEMENT

One textile braid

#### COVER

Environment resistant synthetic rubber

#### APPLICABLE SPECS

Manuli design

#### TYPE APPROVALS

CU-TR

## XTRAFLOW/2WB

HIGH FLOW RATES, LOW PRESSURE DROPS



### KEY FEATURES

- Low pressure drops even with high flow rates
- Superior abrasion resistance
- High ozone and weather resistance
- Flame resistance and electrical antistatic properties of the cover
- High working pressure associated to high flow rates
- Vacuum resistance with SAE 100 R4 performance

### APPLICATIONS & FLUIDS



- Medium-Low pressure hydraulic lines with high flow rates, specific installations with severe abrasion conditions, marine applications, underground and open pit mining, return and suction lines
- Mineral oils, vegetable and rape seed oils, glycol and polyglycol based oils, synthetic ester based oils, oils in aqueous emulsion, water

### TECHNICAL DATA

PART. REF.	HOSE SIZE			R.O.D.		O.D.		MAX W.P.		BURST		MIN. BEND		WEIGHT		FITTINGS	
	DN	dash	inch	mm	inch	mm	inch	bar	psi	bar	psi	mm	inch	g/m	lb/ft	Std1	Std2
H01129063*	63	- 40	2.1/2"	75,8	2,98	78,5	3,09	105	1520	420	6090	510	20,08	3531	2,37	SP+M05400-40	
H01129076*	76	- 48	3"	89,0	3,50	93,6	3,69	80	1160	320	4640	510	20,08	4976	3,34	SP+M05400-48	
H01129089*	89	- 56	3.1/2"	102,2	4,02	107,4	4,23	35	500	140	2030	710	27,95	5530	3,72	SP+M05400-56	

#### CONTINUOUS SERVICE TEMPERATURE RANGE

-40 °F / 212 °F  
-40 °C / 100 °C

#### TUBE

Oil resistant synthetic rubber

#### REINFORCEMENT

Two high tensile steel wire braids

#### COVER

Synthetic rubber with high ozone, weather and abrasion resistance

#### APPLICABLE SPECS

Extension EN 857-2SC, ISO 11237-2SC

#### TYPE APPROVALS

CU-TR; MSHA

## XTRAFLOW/4WS

HIGH FLOW RATES, OUTSTANDING ABRASION RESISTANCE



### KEY FEATURES

- Low pressure drops even with high flow rates
- Extreme abrasion resistance
- High ozone and weather resistance
- Flame retardant and antistatic cover
- Superior pressure rating
- Structure robustness for tough handling

### APPLICATIONS & FLUIDS

- General hydraulics with high flow rates, mine hydraulic return lines, longwalls water lines
- Mineral oils, vegetable oils and synthetic ester based oils, glycols and polyglycols, mineral oils in aqueous emulsion, water

### TECHNICAL DATA

PART. REF.	HOSE SIZE			R.O.D.		O.D.		MAX W.P.		BURST		MIN.BEND		WEIGHT		FITTINGS	
	DN	dash	inch	mm	inch	mm	inch	bar	psi	bar	psi	mm	inch	g/m	lb/ft	Std1	Std2
H10091063*	63	- 40	2.1/2"	77,5	3,05	81,5	3,21	140	2030	700	10150	700	27,56	5890	3,96	SP+M05400-40	
H10091076*	76	- 48	3"	87,8	3,46	92,2	3,63	105	1520	525	7610	700	27,56	5367	3,61	SP+M05400-48	
H10091089*	89	- 56	3.1/2"	103,7	4,08	108,7	4,28	80	1160	400	5800	800	31,50	8187	5,50	SP+M05400-56	
H10091102*	102	- 64	4"	120,0	4,72	126,0	4,96	35	500	140	2030	900	35,43	10210	6,86	SP+M05400-64	

#### CONTINUOUS SERVICE TEMPERATURE RANGE

-40 °F / 212 °F  
-40 °C / 100 °C

#### TUBE

Oil resistant synthetic rubber

#### REINFORCEMENT

Four high tensile steel wire spirals

#### COVER

Synthetic rubber with high abrasion, ozone and weather resistance

#### APPLICABLE SPECS

Manuli Design

#### TYPE APPROVALS

CU-TR; MSHA; FRAS

## XTRAFLOW/HT

HIGH TEMPERATURE SUCTION & RETURN LINES



### KEY FEATURES

- Vacuum resistance exceeding SAE 100R4 performance
- Extreme high temperature and heat aging resistance
- High flow rates
- Reduced bend radii compared to SAE 100R4

### APPLICATIONS & FLUIDS



- Suction and return lines in hydraulic systems with high temperature fluids, low pressure hydraulic systems in mining equipment.
- Remark: compressed air applications require cover pin-pricking and additional safety devices.
- Mineral oils, glycols and polyglycols, transmission fluids, mineral oils in aqueous emulsion (up to 212°F 100°C), air with oil vapours.

### TECHNICAL DATA

PART. REF.	HOSE SIZE		R.O.D.		O.D.		MAX W.P.		BURST		MIN.BEND		WEIGHT		FITTINGS		
	DN	dash	inch	mm	inch	mm	inch	bar	psi	bar	psi	mm	inch	g/m	lb/ft	Std1	Std2
H01128063*	63	- 40	2.1/2"	75,8	2,98	78,5	3,09	35	500	140	2030	254	10,00	3589	2,41	MF+M03400-40	
H01128076*	76	- 48	3"	87,8	3,46	90,5	3,56	35	500	140	2030	355	13,98	3291	2,21	MF+M03400-48	
H01128089*	89	- 56	3.1/2"	102,2	4,02	106,0	4,17	35	500	140	2030	475	18,70	5708	3,84	MF+M03400-56	

#### CONTINUOUS SERVICE TEMPERATURE RANGE

-67 °F / 275 °F  
-55 °C / 135 °C

#### MAX OPERATING TEMPERATURE

150 °C, 300 °F

#### TUBE

Oil resistant synthetic rubber

#### REINFORCEMENT

Two wire braids of high tensile steel wire

#### COVER

Synthetic rubber with high ozone, weather and heat resistance

#### APPLICABLE SPECS

Manuli design

#### TYPE APPROVALS

CU-TR; MSHA

## GOLDENISO/21 ANTIWEAR

OUTSTANDING ABRASION RESISTANCE



### KEY FEATURES

- Extreme abrasion resistance
- Very low bend radius to suit restricted space installations
- High robust and compact hose structure compared to rated pressure
- Approved at 200.000 impulse cycles, at T=100°C (ISO 18752 grade A)
- High environmental agents resistance
- Vacuum resistance accordingly to SAE 100R4 requirements

### APPLICATIONS & FLUIDS

- Medium and high pressure hydraulic lines with installation constraints, pilot lines, return, drain and suction lines
- Mineral oils, vegetable oils and synthetic ester based oils (up to 100°C/212°F), glycols and polyglycols, mineral oils in aqueous emulsion, water

### TECHNICAL DATA

PART. REF.	HOSE SIZE			R.O.D.		O.D.		MAX W.P.		BURST		MIN.BEND		WEIGHT		FITTINGS	
	DN	dash	inch	mm	inch	mm	inch	bar	psi	bar	psi	mm	inch	g/m	lb/ft	Std1	Std2
H01125A05*	5	- 3	3/16"	9,1	0,36	11,1	0,44	210	3040	840	12180	45	1,77	170	0,11	MF+M03300-03	OPF-03
H01125006*	6	- 4	1/4"	10,2	0,40	12,0	0,47	210	3040	840	12180	50	1,97	180	0,12	MF+M03300-04	OPF-04
H01125008*	8	- 5	5/16"	11,5	0,45	13,6	0,54	210	3040	840	12180	55	2,17	210	0,14	MF+M03300-05	OPF-05
H01125010*	10	- 6	3/8"	14,4	0,57	16,2	0,64	210	3040	840	12180	65	2,56	300	0,20	MF+M03400-06	OPF-06
H01125012*	12	- 8	1/2"	17,9	0,70	19,7	0,78	210	3040	840	12180	90	3,54	415	0,28	MF+M03400-08	OPF-08
H01125016*	16	- 10	5/8"	22,2	0,87	24,0	0,94	210	3040	840	12180	100	3,94	620	0,42	MF+M03400-10	OPF-10
H01125019*	19	- 12	3/4"	25,6	1,01	27,7	1,09	210	3040	840	12180	120	4,72	780	0,52	MF+M03400-12	OPF-12
H01125025*	25	- 16	1"	33,0	1,30	35,2	1,39	210	3040	840	12180	150	5,91	1120	0,75	MF+M03400-16	OPF-16

### CONTINUOUS SERVICE TEMPERATURE RANGE

-40 °F / 212 °F  
-40 °C / 100 °C

### MAX OPERATING TEMPERATURE

121 °C, 250 °F

### TUBE

Synthetic rubber

### REINFORCEMENT

One wire braid (DN 5÷12). Two wire braid (DN 16÷25)

### COVER

High abrasion resistant synthetic rubber

### APPLICABLE SPECS

ISO 18752 grade A; SAE J517 type 100 R17; ISO 11237-R17

### TYPE APPROVALS

CU-TR; MSHA; FRAS

**GOLDENISO/28 ANTIWEAR**

OUTSTANDING ABRASION RESISTANCE

**KEY FEATURES**

- Extreme abrasion resistance
- Very low bend radius to suit restricted space installations
- High robust and compact hose structure compared to rated pressure
- Approved at 200.000 impulse cycles, at T=100°C (ISO 18752 grade A)
- High environmental agents resistance
- Vacuum resistance accordingly to SAE 100R4 requirements

**APPLICATIONS & FLUIDS**

- Medium and high pressure hydraulic lines with installation constraints, pilot lines, return, drain and suction lines
- Mineral oils, vegetable oils and synthetic ester based oils (up to 100°C/212°F), glycols and polyglycols, mineral oils in aqueous emulsion, water

**TECHNICAL DATA**

PART. REF.	HOSE SIZE			R.O.D.		O.D.		MAX W.P.		BURST		MIN.BEND		WEIGHT		FITTINGS	
	DN	dash	inch	mm	inch	mm	inch	bar	psi	bar	psi	mm	inch	g/m	lb/ft	Std1	Std2
H01126006*	6	- 4	1/4"	11,6	0,46	13,2	0,52	280	4060	1120	16240	50	1,97	260	0,17	MF+M03400-04	OPF-04
H01126008*	8	- 5	5/16"	12,9	0,51	14,5	0,57	280	4060	1120	16240	55	2,17	280	0,19	MF+M03400-05	OPF-05
H01126010*	10	- 6	3/8"	15,4	0,61	17,0	0,67	280	4060	1120	16240	63	2,48	380	0,26	MF+M03400-06	OPF-06
H01126012*	12	- 8	1/2"	18,5	0,73	20,3	0,80	280	4060	1120	16240	80	3,15	495	0,33	MF+M03400-08	OPF-08
H01126016*	16	- 10	5/8"	22,7	0,89	24,7	0,97	280	4060	1120	16240	90	3,54	730	0,49	MF+M03400-10	OPF-10
H01126019*	19	- 12	3/4"	27,1	1,07	29,3	1,15	280	4060	1120	16240	120	4,72	1060	0,71	MF+M03400-12	OPK-12

**CONTINUOUS SERVICE TEMPERATURE RANGE**

-40 °F / 212 °F  
-40 °C / 100 °C

**TUBE**

Synthetic rubber

**REINFORCEMENT**

Two wire braids

**COVER**

High abrasion resistant synthetic rubber

**APPLICABLE SPECS**

ISO 18752 grade A; SAE J517 type 100R19

**TYPE APPROVALS**

CU-TR; MSHA; FRAS



## GOLDENISO/21 XTRAFLEX

COMPACTNESS AND FLEXIBILITY



### KEY FEATURES

- Bend radius which exceed the standard requirements by -50%
- Good flexibility in the whole temperature range
- Easy mounting in any installation
- High impulse resistance according to ISO 18752 requirements
- Weight saving vs traditional R12 hose construction, despite the higher working pressure of the GoldenIso Xtraflex range
- No-skive fitting solution is available
- Isobaric pressure rating for easy selection and product management

### APPLICATIONS & FLUIDS



- Medium pressure hydraulic lines for general hydraulics
- Return lines of hydraulic systems
- Applications with installation constraints (short assemblies, compact spaces, low bend radii, etc.)
- Mineral oils, vegetable oils and synthetic ester based oils (up to 100°C/212°F), glycols and polyglycols, mineral oils in aqueous emulsion, water

### TECHNICAL DATA

PART. REF.	HOSE SIZE			R.O.D.		O.D.		MAX W.P.		BURST		MIN.BEND		WEIGHT		FITTINGS	
	DN	dash	inch	mm	inch	mm	inch	bar	psi	bar	psi	mm	inch	g/m	lb/ft	Std1	Std2
H10093031*	31	-20	1.1/4"	41,7	1,64	44,5	1,75	210	3040	840	12180	210	8,27	2071	1,39	MF+M00920-20	OPK-20
H10093038*	38	-24	1.1/2"	48,9	1,93	52,1	2,05	210	3040	840	12180	260	10,24	2989	2,01	IP+M01500-24	SP+M05400-24
H10093051*	51	-32	2"	63,2	2,49	66,8	2,63	210	3040	840	12180	330	12,99	4311	2,90	IP+M01500-32	SP+M05400-32

#### CONTINUOUS SERVICE TEMPERATURE RANGE

-50 °F / 250 °F  
-46 °C / 121 °C

#### MAX OPERATING TEMPERATURE

125 °C, 257 °F

#### TUBE

Oil resistant synthetic rubber

#### REINFORCEMENT

4 high tensile steel spirals

#### COVER

Synthetic rubber with high abrasion, ozone, weather and heat resistance

#### APPLICABLE SPECS

ISO 18752-C/D; JIS K6349-3

#### TYPE APPROVALS

CU-TR; MSHA; FRAS

## GOLDENISO/28 XTRAFLEX

COMPACTNESS AND FLEXIBILITY



### KEY FEATURES

- Bend radius which exceed the standard requirements by - 30% to -50%
- Good flexibility in the whole temperature range
- Easy mounting in any installation
- High impulse resistance according to ISO 18752 requirements
- Weight saving of 20% vs traditional R12 hose construction
- No-skive fitting solution is available
- Isobaric pressure rating for easy selection and product management

### APPLICATIONS & FLUIDS



- High pressure power lines for general hydraulics
- Applications with installation constraints (short assemblies, compact spaces, low bend radii, etc.)
- Mineral oils, vegetable oils and synthetic ester based oils (up to 100°C/212°F), glycols and polyglycols, mineral oils in aqueous emulsion, water

### TECHNICAL DATA

PART. REF.	HOSE SIZE			R.O.D.		O.D.		MAX W.P.		BURST		MIN.BEND		WEIGHT		FITTINGS	
	DN	dash	inch	mm	inch	mm	inch	bar	psi	bar	psi	mm	inch	g/m	lb/ft	Std1	Std2
H10095010*	10	- 6	3/8"	16,7	0,66	18,9	0,74	280	4060	1120	16240	65	2,56	520	0,35	MF+M00910-06	OPK-06
H10095012*	12	- 8	1/2"	19,6	0,77	21,8	0,86	280	4060	1120	16240	90	3,54	650	0,44	MF+M00910-08	OPK-08
H10095016*	16	- 10	5/8"	23,5	0,93	25,7	1,01	280	4060	1120	16240	100	3,94	934	0,63	MF+M00910-10	OPK-10
H10095019*	19	- 12	3/4"	26,9	1,06	29,3	1,15	280	4060	1120	16240	120	4,72	1040	0,70	MF+M00920-12	OPK-12
H10095025*	25	- 16	1"	34,1	1,34	36,5	1,44	280	4060	1120	16240	150	5,91	1530	1,03	MF+M00930-16	OPK-16
H10095031*	31	- 20	1.1/4"	41,7	1,64	44,5	1,75	280	4060	1120	16240	210	8,27	2160	1,45	MF+M00920-20	OPK-20
H10095038*	38	- 24	1.1/2"	48,9	1,93	52,1	2,05	280	4060	1120	16240	280	11,02	2994	2,01	IP+M01500-24	SP+M05400-24
H10095051*	51	- 32	2"	63,9	2,52	67,5	2,66	280	4060	1120	16240	350	13,78	4633	3,11	IP+M01500-32	SP+M05400-32

#### CONTINUOUS SERVICE TEMPERATURE RANGE

-50 °F / 250 °F  
-46 °C / 121 °C

#### MAX OPERATING TEMPERATURE

125 °C, 257 °F

#### TUBE

Oil resistant synthetic rubber

#### REINFORCEMENT

4 high tensile steel spirals

#### COVER

Synthetic rubber with high abrasion, ozone, weather and heat resistance

#### APPLICABLE SPECS

ISO 18752-C/D; JIS K6349-3

#### TYPE APPROVALS

CU-TR; MSHA; FRAS; CCS

## GOLDENISO/35 XTRAFLEX

COMPACTNESS AND FLEXIBILITY



### KEY FEATURES

- Bend radius which exceed the standard requirements by - 30% to -50%
- Good flexibility in the whole temperature range
- Easy mounting in any installation
- High impulse resistance according to ISO 18752 requirements
- Weight saving of 20% vs traditional R13 hose construction
- No-skive fitting solution is available
- Isobaric pressure rating for easy selection and product management

### APPLICATIONS & FLUIDS



- High pressure power lines for general hydraulics
- Applications with installation constraints (short assemblies, compact spaces, low bend radii, etc.)
- Mineral oils, vegetable oils and synthetic ester based oils (up to 100°C/212°F), glycols and polyglycols, mineral oils in aqueous emulsion, water

### TECHNICAL DATA

PART. REF.	HOSE SIZE			R.O.D.		O.D.		MAX W.P.		BURST		MIN.BEND		WEIGHT		FITTINGS	
	DN	dash	inch	mm	inch	mm	inch	bar	psi	bar	psi	mm	inch	g/m	lb/ft	Std1	Std2
H10096010*	10	- 6	3/8"	16,7	0,66	18,9	0,74	350	5070	1400	20300	80	3,15	530	0,36	MF+M00910-06	OPK-06
H10096012*	12	- 8	1/2"	19,6	0,77	21,8	0,86	350	5070	1400	20300	90	3,54	660	0,44	MF+M00910-08	OPK-08
H10096016*	16	- 10	5/8"	23,5	0,93	25,7	1,01	350	5070	1400	20300	100	3,94	934	0,63	MF+M00910-10	OPK-10
H10096019*	19	- 12	3/4"	27,5	1,08	29,9	1,18	350	5070	1400	20300	120	4,72	1220	0,82	MF+M00920-12	OPK-12
H10096025*	25	- 16	1"	34,6	1,36	37,0	1,46	350	5070	1400	20300	150	5,91	1800	1,21	IP+M01500-16	SP+M05400-16
H10096031*	31	- 20	1.1/4"	42,1	1,66	44,9	1,77	350	5070	1400	20300	230	9,06	2340	1,57	IP+M01500-20	SP+M05400-20
H10096038*	38	- 24	1.1/2"	52,9	2,08	56,1	2,21	350	5070	1400	20300	300	11,81	4165	2,80	IP+M01600-24	SP+M05500-24
H10096051*	51	- 32	2"	66,8	2,63	70,4	2,77	350	5070	1400	20300	360	14,17	6161	4,14	IP+M01800-32	SP+M05500-32

#### CONTINUOUS SERVICE TEMPERATURE RANGE

-50 °F / 250 °F  
-46 °C / 121 °C

#### MAX OPERATING TEMPERATURE

125 °C, 257 °F

#### TUBE

Oil resistant synthetic rubber

#### REINFORCEMENT

Four high tensile steel spirals (DN 6÷31). Six high tensile steel spirals (DN 38÷51).

#### COVER

Synthetic rubber with high abrasion, ozone, weather and heat resistance

#### APPLICABLE SPECS

ISO 18752-C/D, JIS K6349-3

#### TYPE APPROVALS

DNV-GL; CU-TR; MSHA; FRAS; B

## GOLDENISO/42 XTRAFLEX

COMPACTNESS AND FLEXIBILITY



### KEY FEATURES

- Bend radius which exceed the standard requirements by - 30% to -50%
- Good flexibility in the whole temperature range
- Easy mounting in any installation
- High impulse resistance according to ISO 18752 requirements
- Weight saving of 20% vs traditional R15 hose construction
- No-skive fitting solution is available
- Isobaric pressure rating for easy selection and product management

### APPLICATIONS & FLUIDS



- High pressure power lines for general hydraulics
- Heavy duty power lines
- Applications with installation constraints (short assemblies, compact spaces, low bend radii, etc.)
- Mineral oils, vegetable oils and synthetic ester based oils (up to 100°C/212°F), glycols and polyglycols, mineral oils in aqueous emulsion, water

### TECHNICAL DATA

PART. REF.	HOSE SIZE			R.O.D.		O.D.		MAX W.P.		BURST		MIN.BEND		WEIGHT		FITTINGS	
	DN	dash	inch	mm	inch	mm	inch	bar	psi	bar	psi	mm	inch	g/m	lb/ft	Std1	Std2
H10097010*	10	- 6	3/8"	17,6	0,69	20,0	0,79	420	6090	1680	24360	100	3,94	550	0,37	MF+M00910-06	
H10097012*	12	- 8	1/2"	20,3	0,80	22,7	0,89	420	6090	1680	24360	120	4,72	807	0,54	MF+M00910-08	
H10097016*	16	- 10	5/8"	23,9	0,94	26,4	1,04	420	6090	1680	24360	140	5,51	989	0,66	IP+M01500-10	SP+M05400-10
H10097019*	19	- 12	3/4"	27,7	1,09	30,2	1,19	420	6090	1680	24360	150	5,91	1285	0,86	IP+M01500-12	SP+M05400-12
H10097025*	25	- 16	1"	34,8	1,37	37,3	1,47	420	6090	1680	24360	210	8,27	1915	1,29	IP+M01500-16	SP+M05400-16
H10097031*	31	- 20	1.1/4"	46,3	1,82	49,5	1,95	420	6090	1680	24360	260	10,24	3663	2,46	IP+M01600-20	SP+M05500-20
H10097038*	38	- 24	1.1/2"	53,2	2,09	56,4	2,22	420	6090	1680	24360	310	12,20	4450	2,99	IP+M01600-24	SPGX+ M05500-24GX

#### CONTINUOUS SERVICE TEMPERATURE RANGE

-50 °F / 250 °F  
-46 °C / 121 °C

#### MAX OPERATING TEMPERATURE

125 °C, 257 °F

#### TUBE

Oil resistant synthetic rubber

#### REINFORCEMENT

Four high tensile steel spirals (DN 6÷25). Six high tensile steel spirals (DN 31÷51).

#### COVER

Synthetic rubber with high abrasion, ozone, weather and heat resistance

#### APPLICABLE SPECS

ISO 18752-C (Grade C "Plus" approved 1 Mil impulse cycles with Interlock Plus fittings)

#### TYPE APPROVALS

CU-TR; MSHA; FRAS; B

## GOLDENISO/35 LONGLIFE

HIGH FATIGUE RESISTANCE



### KEY FEATURES



- Designed for original equipment
- Long-term mission profile in severe applications
- Over standard pressure rating
- High impulse resistance exceeding the ISO 18752 requirements
- Superior abrasion resistance
- High ozone and weather resistance
- Flame retardant and antistatic properties of the cover
- Wide compatibility with hydraulic fluids, mineral and biodegradable oils
- Low bend radius, better than the standard requirements
- Skive robust fitting solution
- Isobaric pressure rating for easy selection and product management

### APPLICATIONS & FLUIDS



- Hydraulics: high pressure power lines, heavy duty earth moving equipment, drilling applications, lifting equipment and telescopic booms, injection moulding machines, specific installations with severe abrasion conditions and/or harsh environmental conditions, marine applications, underground and open pit mining
- Mineral oils, vegetable oils and synthetic ester based oils (up to 100°C/212°F), glycols and polyglycols, mineral oils in aqueous emulsion, water

### TECHNICAL DATA

PART. REF.	HOSE SIZE			R.O.D.		O.D.		MAX W.P.		BURST		MIN.BEND		WEIGHT		FITTINGS	
	DN	dash	inch	mm	inch	mm	inch	bar	psi	bar	psi	mm	inch	g/m	lb/ft	Std1	Std2
H01134006*	6	- 4	1/4"	11,3	0,44	13,1	0,52	350	5070	1800	26100	45	1,77	284	0,19	MF+M00120-04	
H01134010*	10	- 6	3/8"	15,0	0,59	16,8	0,66	350	5070	1400	20300	65	2,56	392	0,26	MF+M00120-06	

#### CONTINUOUS SERVICE TEMPERATURE RANGE

-40 °F / 212 °F  
-40 °C / 100 °C

#### MAX OPERATING TEMPERATURE

125 °C, 257 °F

#### TUBE

Oil resistant synthetic rubber

#### REINFORCEMENT

Two high tensile steel wire braids (DN 6 to 12)

#### COVER

Synthetic rubber with high ozone, abrasion and weather resistance

#### APPLICABLE SPECS

Manuli special design exceeds ISO 18752-B

#### TYPE APPROVALS

CU-TR; MSHA

## GOLDENISO/38 LONGLIFE

HIGH FATIGUE RESISTANCE



### KEY FEATURES

- Designed for original equipment
- Long-term mission profile in severe applications
- Over standard pressure rating
- High impulse resistance exceeding the ISO 18752 requirements
- Superior abrasion resistance
- High ozone and weather resistance
- Flame retardant and antistatic properties of the cover
- Wide compatibility with hydraulic fluids, mineral and biodegradable oils
- Low bend radius, better than the standard requirements
- Interlock-Plus easy mounting system for a very high-level robustness
- Isobaric pressure rating for easy selection and product management

### APPLICATIONS & FLUIDS



- Heavy duty pressure lines, hydrostatic transmissions, heavy duty earth moving equipment, hydraulic presses, drilling applications, injection moulding machines, specific installations with severe abrasion conditions and/or harsh environmental conditions, marine applications, underground and open pit mining
- Mineral oils, vegetable oils and synthetic ester based oils (up to 100°C/212°F), glycols and polyglycols, mineral oils in aqueous emulsion, water

### TECHNICAL DATA

PART. REF.	HOSE SIZE			R.O.D.		O.D.		MAX W.P.		BURST		MIN. BEND		WEIGHT		FITTINGS	
	DN	dash	inch	mm	inch	mm	inch	bar	psi	bar	psi	mm	inch	g/m	lb/ft	Std1	Std2
H10098019*	19	- 12	3/4"	27,7	1,09	32,0	1,26	380	5510	1680	24360	170	6,69	1410	0,95	IP+M01500-12	
H10098025*	25	- 16	1"	34,8	1,37	38,1	1,50	380	5510	1680	24360	220	8,66	1964	1,32	IP+M01500-16	
H10098031*	31	- 20	1.1/4"	46,3	1,82	49,5	1,95	380	5510	1680	24360	267	10,51	3663	2,46	IP+M01600-20	
H10098038*	38	- 24	1.1/2"	55,2	2,17	59,1	2,33	380	5510	1900	27550	500	19,69	5280	3,55	IP+M01800-24	
H10098051*	51	- 32	2"	68,4	2,69	72,4	2,85	380	5510	1520	22040	630	24,80	6796	4,57	IP+M01800-32	

#### CONTINUOUS SERVICE TEMPERATURE RANGE

-40 °F / 250 °F  
-40 °C / 121 °C

#### MAX OPERATING TEMPERATURE

125 °C, 257 °F

#### TUBE

Oil resistant synthetic rubber

#### REINFORCEMENT

Four high tensile steel wire spirals (DN 19 & 25),  
six high tensile steel wire spirals (DN 31)

#### COVER

Synthetic rubber with high ozone, abrasion and weather resistance

#### APPLICABLE SPECS

Manuli special design exceeds SAE J517 type100R13; ISO 3862 R13; ISO 18752-C-D extension

#### TYPE APPROVALS

CU-TR; MSHA; FRAS

## GOLDENISO/45 LONGLIFE

HIGH FATIGUE RESISTANCE



### KEY FEATURES

- Designed for original equipment
- Long-term mission profile in severe applications
- Over standard pressure rating
- High impulse resistance exceeding the ISO 18752 requirements
- Superior abrasion resistance
- High ozone and weather resistance
- Flame retardant and antistatic properties of the cover
- Wide compatibility with hydraulic fluids, mineral and biodegradable oils
- Low bend radius, better than the standard requirements
- Interlock-Plus easy mounting system for a very high-level robustness
- Isobaric pressure rating for easy selection and product management

### APPLICATIONS & FLUIDS



- Heavy duty pressure lines, hydrostatic transmissions, heavy duty earth moving equipment, hydraulic presses, drilling applications, injection moulding machines, specific installations with severe abrasion conditions and/or harsh environmental conditions, marine applications, underground and open pit mining
- Mineral oils, vegetable oils and synthetic ester based oils (up to 100°C/212°F), glycols and polyglycols, mineral oils in aqueous emulsion, water

### TECHNICAL DATA

PART. REF.	HOSE SIZE			R.O.D.		O.D.		MAX W.P.		BURST		MIN. BEND		WEIGHT		FITTINGS	
	DN	dash	inch	mm	inch	mm	inch	bar	psi	bar	psi	mm	inch	g/m	lb/ft	Std1	Std2
H10089006*	6	- 4	1/4"	14,7	0,58	17,1	0,67	460	6670	1840	26680	125	4,92	567	0,38	IP+M01500-04	
H10089016*	16	- 10	5/8"	25,5	1,00	28,5	1,12	460	6670	1840	26680	250	9,84	1290	0,87	IP+M01500-10	
H10089019*	19	- 12	3/4"	28,4	1,12	32,0	1,26	460	6670	1840	26680	280	11,02	1530	1,03	IP+M01500-12	
H10089025*	25	- 16	1"	35,4	1,39	38,2	1,50	460	6670	1840	26680	340	13,39	2150	1,44	IP+M01500-16	
H10089031*	31	- 20	1.1/4"	46,3	1,82	49,5	1,95	450	6520	1800	26100	420	16,54	3790	2,55	IP+M01800-20	

#### CONTINUOUS SERVICE TEMPERATURE RANGE

-40 °F / 250 °F  
-40 °C / 121 °C

#### MAX OPERATING TEMPERATURE

125 °C, 257 °F

#### TUBE

Oil resistant synthetic rubber

#### REINFORCEMENT

Four high tensile steel wire spirals (DN 16÷25).  
Six high tensile steel wire spirals (DN 31)

#### COVER

Synthetic rubber with high ozone, abrasion and weather resistance

#### APPLICABLE SPECS

Manuli special design exceeds SAE J517 type100R15; ISO 3862 R15; ISO 18752-D extension

#### TYPE APPROVALS

CU-TR; MSHA; FRAS

## SHIELDMASTER/2000

OUTSTANDING ABRASION RESISTANCE



### KEY FEATURES

- Outstanding abrasion and ozone resistance
- Compact overall dimensions
- Easy assembling and mounting operations (no protection sleeves required)
- Isobaric pressure rating
- FROST suitable for very cold environments
- Compact solution for difficult installation

### APPLICATIONS & FLUIDS



- Low pressure hydraulic lines, pilot lines with shield architecture
- High resistance to abrasion conditions, including rubbing among hoses in bunches, alternative to spring guards, ease of cleaning in dusty environments
- For severe environmental conditions, long resistance to ozone and weathering, cold temperatures, dirty industrial environments
- Mineral oils, vegetable and rape seed oils, glycol and polyglycol based oils, synthetic ester based oils, oils in aqueous emulsion, water

### TECHNICAL DATA

PART. REF.	HOSE SIZE			R.O.D.		O.D.		MAX W.P.		BURST		MIN.BEND		WEIGHT		FITTINGS	
	DN	dash	inch	mm	inch	mm	inch	bar	psi	bar	psi	mm	inch	g/m	lb/ft	Std1	Std2
H01106A06*	6	- 4	1/4"	10,2	0,40	12,3	0,48	140	2030	560	8120	50	1,97	185	0,12	MF+M00120-04	OPF-04
H01106010*	10	- 6	3/8"	13,6	0,54	15,8	0,62	140	2030	560	8120	60	2,36	270	0,18	MF+M00120-06	
H01106012*	12	- 8	1/2"	17,1	0,67	19,3	0,76	140	2030	560	8120	70	2,76	350	0,24	MF+M00120-08	

#### CONTINUOUS SERVICE TEMPERATURE RANGE

-50 °F / 212 °F  
-46 °C / 100 °C

#### MAX OPERATING TEMPERATURE

125 °C, 257 °F

#### MIN EXTERNAL TEMPERATURE

-55 °C, -67 °F

#### TUBE

Oil resistant synthetic rubber

#### REINFORCEMENT

One high tensile steel braid

#### COVER

Composite bi-layer structure with outstanding abrasion resistance

#### APPLICABLE SPECS

MANULI® Design

#### TYPE APPROVALS

CU-TR



#### Remarks:

Applications with materials projection or winding on low bend radius pulley systems should be field tested before use; high abrasion resistant rubber cover hoses are appropriate in most cases.



## SHIELDMASTER/4000

OUTSTANDING ABRASION RESISTANCE



### KEY FEATURES

- Outstanding abrasion and ozone resistance
- Compact overall dimensions
- Easy assembling and mounting operations (no protection sleeves required)
- Isobaric pressure rating
- FROST suitable for very cold environments

### APPLICATIONS & FLUIDS



- High pressure hydraulic lines
- High resistance to abrasion conditions, including rubbing among hoses in bunches, alternative to spring guards, ease of cleaning in dusty environments
- For severe environmental conditions, long resistance to ozone and weathering, cold temperatures, dirty industrial environments
- Mineral oils, vegetable oils and synthetic ester based oils (up to 100°C/212°F), glycols and polyglycols, mineral oils in aqueous emulsion, water

### TECHNICAL DATA

PART. REF.	HOSE SIZE			R.O.D.		O.D.		MAX W.P.		BURST		MIN.BEND		WEIGHT		FITTINGS	
	DN	dash	inch	mm	inch	mm	inch	bar	psi	bar	psi	mm	inch	g/m	lb/ft	Std1	Std2
H01031006*	6	- 4	1/4"	11,6	0,46	13,6	0,54	276	4000	1110	16090	50	1,97	275	0,18	MF+M00120-04	
H01031008*	8	- 5	5/16"	12,9	0,51	14,9	0,59	276	4000	1110	16090	57	2,24	324	0,22	MF+M00120-05	
H01031010*	10	- 6	3/8"	15,4	0,61	17,4	0,69	276	4000	1110	16090	63	2,48	400	0,27	MF+M00120-06	
H01031012*	12	- 8	1/2"	18,5	0,73	20,5	0,81	276	4000	1110	16090	80	3,15	510	0,34	MF+M00120-08	
H01031016*	16	- 10	5/8"	22,7	0,89	24,7	0,97	276	4000	1110	16090	90	3,54	730	0,49	MF+M00120-10	
H01031019*	19	- 12	3/4"	27,1	1,07	29,3	1,15	276	4000	1110	16090	120	4,72	1070	0,72	MF+M00120-12	
H01031025*	25	- 16	1"	35,1	1,38	38,1	1,50	276	4000	1110	16090	267	10,51	1950	1,31	MF+M00930-16	
H01031031*	31	- 20	1.1/4"	43,8	1,72	47,0	1,85	276	4000	1110	16090	400	15,75	2590	1,74	MF+M00920-20	
H01031038*	38	- 24	1.1/2"	50,0	1,97	53,5	2,11	276	4000	1110	16090	500	19,69	3160	2,12	MF+M00910-24	
H01031051*	51	- 32	2"	63,5	2,50	68,0	2,68	276	4000	1110	16090	700	27,56	4580	3,08	IP+M01500-32	

#### CONTINUOUS SERVICE TEMPERATURE RANGE

-50 °F / 212 °F  
-46 °C / 100 °C

#### MAX OPERATING TEMPERATURE

125 °C, 257 °F

#### MIN EXTERNAL TEMPERATURE

-55 °C, -67 °F

#### TUBE

Oil resistant synthetic rubber

#### REINFORCEMENT

Two high tensile steel braids (DN 6÷19). Four high tensile steel spirals (DN 25÷51)

#### COVER

Composite bi-layer structure with outstanding abrasion resistance

#### APPLICABLE SPECS

MANULI® Design

#### TYPE APPROVALS

CU-TR



#### Remarks:

Applications with materials projection or winding on low bend radius pulley systems should be field tested before use; high abrasion resistant rubber cover hoses are appropriate in most cases.

## SHIELDMASTER/5000

OUTSTANDING ABRASION RESISTANCE



### KEY FEATURES

- Outstanding abrasion and ozone resistance
- Compact overall dimensions
- Easy assembling and mounting operations (no protection sleeves required)
- Isobaric pressure rating
- FROST suitable for very cold environments

### APPLICATIONS & FLUIDS



- High pressure hydraulic lines
- High resistance to abrasion conditions, including rubbing among hoses in bunches, alternative to spring guards, ease of cleaning in dusty environments
- For severe environmental conditions, long resistance to ozone and weathering, cold temperatures, dirty industrial environments
- Mineral oils, vegetable oils and synthetic ester based oils (up to 100°C/212°F), glycols and polyglycols, mineral oils in aqueous emulsion, water

### TECHNICAL DATA

PART. REF.	HOSE SIZE			R.O.D.		O.D.		MAX W.P.		BURST		MIN.BEND		WEIGHT		FITTINGS	
	DN	dash	inch	mm	inch	mm	inch	bar	psi	bar	psi	mm	inch	g/m	lb/ft	Std1	Std2
H01032006*	6	- 4	1/4"	11,6	0,46	13,6	0,54	345	5000	1380	20010	50	1,97	275	0,18	MF+M00120-04	
H01032008*	8	- 5	5/16"	12,9	0,51	15,1	0,59	345	5000	1380	20010	55	2,17	340	0,23	MF+M00120-05	
H01032010*	10	- 6	3/8"	15,0	0,59	17,2	0,68	345	5000	1380	20010	65	2,56	400	0,27	MF+M00120-06	
H01032012*	12	- 8	1/2"	19,8	0,78	21,8	0,86	345	5000	1380	20010	120	4,72	650	0,44	MF+M00910-08	
H01032016*	16	- 10	5/8"	24,4	0,96	27,2	1,07	345	5000	1380	20010	200	7,87	995	0,67	MF+M00910-10	
H01032019*	19	- 12	3/4"	28,2	1,11	31,2	1,23	345	5000	1380	20010	230	9,06	1360	0,91	IP+M01500-12	
H01032025*	25	- 16	1"	35,1	1,38	38,1	1,50	345	5000	1380	20010	267	10,51	1950	1,31	IP+M01500-16	

#### CONTINUOUS SERVICE TEMPERATURE RANGE

-50 °F / 212 °F  
-46 °C / 100 °C

#### MAX OPERATING TEMPERATURE

125 °C, 257 °F

#### MIN EXTERNAL TEMPERATURE

-55 °C, -67 °F

#### TUBE

Oil resistant synthetic rubber

#### REINFORCEMENT

Two high tensile steel braids (DN 6÷12). Four high tensile steel spirals (DN 16÷25)

#### COVER

Composite bi-layer structure with outstanding abrasion resistance

#### APPLICABLE SPECS

MANULI® Design

#### TYPE APPROVALS

CU-TR



#### Remarks:

Applications with materials projection or winding on low bend radius pulley systems should be field tested before use; high abrasion resistant rubber cover hoses are appropriate in most cases.

## SHIELDMASTER/6000

OUTSTANDING ABRASION RESISTANCE



### KEY FEATURES

- Outstanding abrasion and ozone resistance
- Compact overall dimensions
- Easy assembling and mounting operations (no protection sleeves required)
- Isobaric pressure rating
- FROST suitable for very cold environments

### APPLICATIONS & FLUIDS



- Heavy duty hydraulic power lines
- High resistance to abrasion conditions, including rubbing among hoses in bunches, alternative to spring guards, ease of cleaning in dusty environments
- For severe environmental conditions, long resistance to ozone and weathering, cold temperatures, dirty industrial environments
- Mineral oils, vegetable oils and synthetic ester based oils (up to 100°C/212°F), glycols and polyglycols, mineral oils in aqueous emulsion, water

### TECHNICAL DATA

PART. REF.	HOSE SIZE			R.O.D.		O.D.		MAX W.P.		BURST		MIN.BEND		WEIGHT		FITTINGS	
	DN	dash	inch	mm	inch	mm	inch	bar	psi	bar	psi	mm	inch	g/m	lb/ft	Std1	Std2
H01A32006*	6	- 4	1/4"	11,3	0,44	13,5	0,53	420	6090	1680	24360	45	1,77	290	0,19	MF+M00120-04	
H01A32010*	10	- 6	3/8"	17,6	0,69	20,6	0,81	420	6090	1680	24360	110	4,33	710	0,48	MF+M00910-06	
H01A32012*	12	- 8	1/2"	20,3	0,80	23,5	0,93	420	6090	1680	24360	120	4,72	840	0,56	MF+M00910-08	
H01A32016*	16	- 10	5/8"	23,7	0,93	27,0	1,06	420	6090	1680	24360	140	5,51	1000	0,67	MF+M00910-10	
H01A32019*	19	- 12	3/4"	28,2	1,11	32,0	1,26	420	6090	1680	24360	170	6,69	1480	0,99	IP+M01500-12	
H01A32025*	25	- 16	1"	35,1	1,38	38,1	1,50	420	6090	1680	24360	220	8,66	2050	1,38	IP+M01500-16	
H01A32031*	31	- 20	1.1/4"	46,3	1,82	49,5	1,95	420	6090	1680	24360	267	10,51	3690	2,48	IP+M01600-20	
H01A32038*	38	- 24	1.1/2"	54,6	2,15	57,8	2,28	420	6090	1680	24360	315	12,40	4780	3,21	IP+M01600-24	
H01A32051*	51	- 32	2"	68,4	2,69	72,0	2,83	420	6090	1680	24360	600	23,62	6760	4,54	XL+M01800-32	

#### CONTINUOUS SERVICE TEMPERATURE RANGE

-50 °F / 212 °F  
-46 °C / 100 °C

#### MAX OPERATING TEMPERATURE

125 °C, 257 °F

#### MIN EXTERNAL TEMPERATURE

-55 °C, -67 °F

#### TUBE

Oil resistant synthetic rubber

#### REINFORCEMENT

Two high tensile steel braids (DN 6). Four high tensile steel spirals (DN 10÷25). Six high tensile steel spirals (DN 31÷51)

#### COVER

Composite bi-layer structure with outstanding abrasion resistance

#### APPLICABLE SPECS

MANULI® Design

#### TYPE APPROVALS

CU-TR



#### Remarks:

Applications with materials projection or winding on low bend radius pulley systems should be field tested before use; high abrasion resistant rubber cover hoses are appropriate in most cases.

## SHIELDMASTER/5000 MINE

OUTSTANDING ABRASION RESISTANCE, MSHA APPROVED



### KEY FEATURES

- MSHA approved cover for mining applications
- Outstanding abrasion and ozone resistance
- Compact overall dimensions
- Easy assembling and mounting operations (no protection sleeves required)
- Indelible branding technology

### APPLICATIONS & FLUIDS



- High pressure hydraulic lines
- High resistance to abrasion conditions, including rubbing among hoses in bunches, alternative to spring guards, ease of cleaning in dusty environments
- For severe mining environments, underground and open pit, long resistance to ozone and weathering, cold temperatures, antistatic and flame retardant properties of the cover
- Mineral oils, vegetable oils and synthetic ester based oils (up to 100°C/212°F), glycols and polyglycols, mineral oils in aqueous emulsion, water

### TECHNICAL DATA

PART. REF.	HOSE SIZE			R.O.D.		O.D.		MAX W.P.		BURST		MIN.BEND		WEIGHT		FITTINGS	
	DN	dash	inch	mm	inch	mm	inch	bar	psi	bar	psi	mm	inch	g/m	lb/ft	Std1	Std2
H01104006*	6	- 4	1/4"	11,6	0,46	13,6	0,54	345	5000	1380	20010	50	1,97	280	0,19	MF+M00120-04	
H01104008*	8	- 5	5/16"	12,9	0,51	15,1	0,59	345	5000	1380	20010	55	2,17	350	0,24	MF+M00120-05	
H01104010*	10	- 6	3/8"	15,0	0,59	17,2	0,68	345	5000	1380	20010	65	2,56	410	0,28	MF+M00120-06	
H01104012*	12	- 8	1/2"	19,8	0,78	21,8	0,86	345	5000	1380	20010	120	4,72	670	0,45	MF+M00910-08	
H01104016*	16	- 10	5/8"	24,4	0,96	27,2	1,07	345	5000	1380	20010	200	7,87	1030	0,69	MF+M00910-10	
H01104019*	19	- 12	3/4"	28,2	1,11	31,2	1,23	345	5000	1380	20010	230	9,06	1420	0,95	IP+M01500-12	
H01104025*	25	- 16	1"	35,1	1,38	38,1	1,50	345	5000	1380	20010	267	10,51	1990	1,34	IP+M01500-16	
H01104031*	31	- 20	1.1/4"	42,2	1,66	45,2	1,78	345	5000	1380	20010	350	13,78	2500	1,68	IP+M01500-20	

#### CONTINUOUS SERVICE TEMPERATURE RANGE

-40 °F / 212 °F  
-40 °C / 100 °C

#### MAX OPERATING TEMPERATURE

125 °C, 257 °F

#### TUBE

Oil resistant synthetic rubber

#### REINFORCEMENT

Two high tensile steel braids (DN 6÷12). Four high tensile steel spirals (DN 16÷31)

#### COVER

Composite bi-layer structure with outstanding abrasion resistance

#### APPLICABLE SPECS

MANULI® Design. Performances ISO 3862 - R13

#### TYPE APPROVALS

CU-TR; MSHA; FRAS



#### Remarks:

Applications with materials projection or winding on low bend radius pulley systems should be field tested before use; high abrasion resistant rubber cover hoses are appropriate in most cases.

## SHIELDMASTER/6000 MINE

OUTSTANDING ABRASION RESISTANCE, MSHA APPROVED



### KEY FEATURES

- MSHA approved composite cover for mining applications
- Outstanding abrasion and ozone resistance
- Easy assembling and mounting operations, no protection sleeves are required
- Indelible branding technology
- Reduced bend radius for difficult installations
- Flame retardant and electrical antistaticity cover properties

### APPLICATIONS & FLUIDS



- Heavy duty hydraulic power lines
- High resistance to abrasion conditions, including rubbing among hoses in bunches, alternative to spring guards, ease of cleaning in dusty environments
- For severe mining environments, underground and open pit, long resistance to ozone and weathering, cold temperatures, antistatic and flame retardant properties of the cover
- Mineral oils, vegetable oils and synthetic ester based oils (up to 100°C/212°F), glycols and polyglycols, mineral oils in aqueous emulsion, water

### TECHNICAL DATA

PART. REF.	HOSE SIZE			R.O.D.		O.D.		MAX W.P.		BURST		MIN.BEND		WEIGHT		FITTINGS	
	DN	dash	inch	mm	inch	mm	inch	bar	psi	bar	psi	mm	inch	g/m	lb/ft	Std1	Std2
H10086031*	31	-20	1.1/4"	46,3	1,82	49,5	1,95	420	6090	1680	24360	260	10,24	3760	2,53	IP+M01600-20	
H10086038*	38	-24	1.1/2"	54,6	2,15	57,8	2,28	420	6090	1680	24360	310	12,20	4850	3,26	IP+M01600-24	
H10086051*	51	-32	2"	68,4	2,69	72,0	2,83	420	6090	1680	24360	600	23,62	6860	4,61	XL+M01800-32	

#### CONTINUOUS SERVICE TEMPERATURE RANGE

-40 °F / 212 °F  
-40 °C / 100 °C

#### MAX OPERATING TEMPERATURE

125 °C, 257 °F

#### TUBE

Oil resistant synthetic rubber

#### REINFORCEMENT

Six high tensile steel wire spirals

#### COVER

Composite bi-layer structure with outstanding abrasion and ozone resistance

#### APPLICABLE SPECS

ISO 3862 type R15; SAE J517 type 100 R15; exceed performances of BCS 174 (British Coal Specification 1992); ISO 6805 type 6 (rubber hoses and hose assemblies for underground mining)

#### TYPE APPROVALS

MSHA, CU-TR; FRAS



#### Remarks:

Applications with materials projection or winding on low bend radius pulley systems should be field tested before use; high abrasion resistant rubber cover hoses are appropriate in most cases.

## SHIELDMASTER/17 WS

OUTSTANDING ABRASION RESISTANCE



### KEY FEATURES

- MSHA approved cover for mining applications
- Outstanding abrasion and ozone resistance
- Compact overall dimensions
- Easy assembling and mounting operations (no protection sleeves required)
- Indelible branding technology

### APPLICATIONS & FLUIDS



- High pressure hydraulic lines
- High resistance to abrasion conditions, including rubbing among hoses in bunches, alternative to spring guards, ease of cleaning in dusty environments
- For severe mining environments, underground and open pit, long resistance to ozone and weathering, cold temperatures, antistatic and flame retardant properties of the cover
- Mineral oils, vegetable oils and synthetic ester based oils (up to 100°C/212°F), glycols and polyglycols, mineral oils in aqueous emulsion, water

### TECHNICAL DATA

PART. REF.	HOSE SIZE			R.O.D.		O.D.		MAX W.P.		BURST		MIN.BEND		WEIGHT		FITTINGS	
	DN	dash	inch	mm	inch	mm	inch	bar	psi	bar	psi	mm	inch	g/m	lb/ft	Std1	Std2
H10113051*	51	- 32	2"	63,6	2,50	66,7	2,63	175	2530	700	10150	630	24,80	4461	3,00	MF+M00910-32	

#### CONTINUOUS SERVICE TEMPERATURE RANGE

-40 °F / 212 °F  
-40 °C / 100 °C

#### MAX OPERATING TEMPERATURE

125 °C, 257 °F

#### TUBE

Oil resistant synthetic rubber

#### REINFORCEMENT

Four high tensile steel spirals (DN 51)

#### COVER

Composite bi-layer structure with outstanding abrasion resistance

#### APPLICABLE SPECS

MANULI® Design

#### TYPE APPROVALS

CU-TR; MSHA



#### Remarks:

Applications with materials projection or winding on low bend radius pulley systems should be field tested before use; high abrasion resistant rubber cover hoses are appropriate in most cases.

## DIAMONDSPIR/14

HIGH FLOW RATES, OUTSTANDING ABRASION RESISTANCE



### KEY FEATURES

- Extreme abrasion resistance
- High ozone and weather resistance
- Flame retardant and antistatic cover
- Superior pressure rating
- Structure robustness for tough handling
- InterLock robust fitting technology

### APPLICATIONS & FLUIDS



- Medium pressure hydraulic lines with high flow rates, mine hydraulic return lines, large equipment hydraulics
- Mineral oils, vegetable oils and synthetic ester based oils (up to 100°C/212°F), glycols and polyglycols, mineral oils in aqueous emulsion, water

### TECHNICAL DATA

PART. REF.	HOSE SIZE			R.O.D.		O.D.		MAX W.P.		BURST		MIN.BEND		WEIGHT		FITTINGS	
	DN	dash	inch	mm	inch	mm	inch	bar	psi	bar	psi	mm	inch	g/m	lb/ft	Std1	Std2
H10104076*	76	- 48	3"	87,8	3,46	92,2	3,63	140	2030	560	8120	700	27,56	5900	3,96	IP+M01500-48	

#### CONTINUOUS SERVICE TEMPERATURE RANGE

-50 °F / 250 °F  
-46 °C / 121 °C

#### MAX OPERATING TEMPERATURE

125 °C, 257 °F

#### TUBE

Oil resistant synthetic rubber

#### REINFORCEMENT

Four or six high tensile wire spirals

#### COVER

Synthetic rubber with high abrasion, ozone and weather resistance

#### APPLICABLE SPECS

Manuli Design, ISO 18752-C extension

#### TYPE APPROVALS

CU-TR; MSHA; CCS

## DIAMONDSPIR/21

VERY HIGH HYDRAULIC POWER TRANSMISSION



### KEY FEATURES

- Very high flow rates in high pressure hydraulics
- Extreme robustness of the hose structures
- Hose compact dimensions
- Approved with severe fatigue tests
- Superior abrasion resistance
- High ozone and weather resistance
- Flame retardant (MSHA) and antistatic properties
- Biological and mineral oils compatibility
- Crimped InterLock Plus fittings structures

### APPLICATIONS & FLUIDS



- Hydraulics: heavy duty power lines, hydrostatic transmissions in severe environmental conditions, specific installations with tough abrasion conditions, off-shore applications, underground and open pit mining.
- Mineral oils, vegetable oils and synthetic ester based oils (up to 100°C/212°F), glycols and polyglycols, mineral oils in aqueous emulsion, water

### TECHNICAL DATA

PART. REF.	HOSE SIZE			R.O.D.		O.D.		MAX W.P.		BURST		MIN.BEND		WEIGHT		FITTINGS	
	DN	dash	inch	mm	inch	mm	inch	bar	psi	bar	psi	mm	inch	g/m	lb/ft	Std1	Std2
H10102063*	63	- 40	2.1/2"	77,5	3,05	81,5	3,21	210	3040	840	12180	700	27,56	5890	3,96	IP+M01500-40	
H10102076*	76	- 48	3"	90,8	3,57	94,6	3,72	210	3040	840	12180	900	35,43	7910	5,32	IP+M01810-48	

#### CONTINUOUS SERVICE TEMPERATURE RANGE

-50 °F / 250 °F  
-46 °C / 121 °C

#### MAX OPERATING TEMPERATURE

125 °C, 257 °F

#### TUBE

Oil resistant synthetic rubber

#### REINFORCEMENT

Four to six high tensile steel spirals

#### COVER

Synthetic rubber with high abrasion, ozone, weather and heat resistance

#### APPLICABLE SPECS

MANULI® Design: ISO 18752 grade C extension

#### TYPE APPROVALS

CU-TR; MSHA; MA; CCS



## DIAMONDSPIR/35

VERY HIGH HYDRAULIC POWER TRANSMISSION



### KEY FEATURES

- Very high flow rates in high pressure
- Extreme robustness of the hose structures
- Hose compact dimensions
- Approved with severe fatigue tests
- Superior abrasion resistance
- High ozone and weather resistance
- Flame retardant (MSHA) and antistatic properties
- Biological and mineral oils compatibility
- Crimped InterLock Plus & InterLock Super fittings structures

### APPLICATIONS & FLUIDS



- Hydraulics: heavy duty power lines, hydrostatic transmissions in severe environmental conditions, specific installations with tough abrasion conditions, off-shore applications, underground and open pit mining.
- Mineral oils, vegetable oils and synthetic ester based oils (up to 100°C/212°F), glycols and polyglycols, mineral oils in aqueous emulsion, water

### TECHNICAL DATA

PART. REF.	HOSE SIZE			R.O.D.		O.D.		MAX W.P.		BURST		MIN.BEND		WEIGHT		FITTINGS	
	DN	dash	inch	mm	inch	mm	inch	bar	psi	bar	psi	mm	inch	g/m	lb/ft	Std1	Std2
H10103063*	63	- 40	2.1/2"	80,6	3,17	84,8	3,34	350	5070	1400	20300	800	31,50	8105	5,45	IP+M01810-40	
H10103076*	76	- 48	3"	97,9	3,85	101,9	4,01	350	5070	1400	20300	1000	39,37	12249	8,23	IS+M02700-48	IS+M02800-48

#### CONTINUOUS SERVICE TEMPERATURE RANGE

-50 °F / 250 °F  
-46 °C / 121 °C

#### MAX OPERATING TEMPERATURE

125 °C, 257 °F

#### TUBE

Oil resistant synthetic rubber

#### REINFORCEMENT

Six to eight high tensile steel spirals

#### COVER

Synthetic rubber with high abrasion, ozone, weather and heat resistance

#### APPLICABLE SPECS

MANULI® Design: ISO 18752 grade C extension

#### TYPE APPROVALS

CU-TR; MSHA; MA; CCS

## FORESTMASTER/35

FORESTRY MACHINES



### KEY FEATURES

- Extreme high abrasion resistance, long life before reinforcement scratching
- Special composite cover layer with textile reinforcement for the maximum resistance in harsh environments
- Reduced bend radius
- Good flexibility in the whole temperature range
- Easy mounting in any installation
- High impulse resistance according to ISO 18752 requirements

### APPLICATIONS & FLUIDS



- High pressure power lines for general hydraulics
- Designed for forestry machines booms and harvester heads, harsh environments and severe abrasions
- Mineral oils, vegetable oils and synthetic ester based oils (up to 100°C/212°F), glycols and polyglycols, mineral oils in aqueous emulsion, water

### TECHNICAL DATA

PART. REF.	HOSE SIZE			R.O.D.		O.D.		MAX W.P.		BURST		MIN.BEND		WEIGHT		FITTINGS	
	DN	dash	inch	mm	inch	mm	inch	bar	psi	bar	psi	mm	inch	g/m	lb/ft	Std1	Std2
H10111019*	19	- 12	3/4"	27,5	1,08	31,7	1,25	350	5070	1400	20300	140	5,51	1251	0,84	IP+M01500-12	SP+M05400-12
H10111025*	25	- 16	1"	34,6	1,36	38,8	1,53	350	5070	1400	20300	190	7,48	1843	1,24	IP+M01500-16	SP+M05400-16
H10111031*	31	- 20	1.1/4"	42,1	1,66	47,1	1,85	350	5070	1400	20300	230	9,06	2484	1,67	IP+M01500-20	

#### CONTINUOUS SERVICE TEMPERATURE RANGE

-50 °F / 250 °F  
-46 °C / 121 °C

#### MAX OPERATING TEMPERATURE

125 °C, 257 °F

#### TUBE

Oil resistant synthetic rubber

#### REINFORCEMENT

Four high tensile steel spirals

#### COVER

Composite cover with textile reinforcement, realized with high abrasion and ozone resistant synthetic rubber

#### APPLICABLE SPECS

Manuli design, ref. ISO 18752-C

#### TYPE APPROVALS

CU-TR; MSHA

## FORESTMASTER/42

FORESTRY MACHINES



### KEY FEATURES

- Extreme high abrasion resistance, long life before reinforcement scratching
- Special composite cover layer with textile reinforcement for the maximum resistance in harsh environments
- Reduced bend radius
- Good flexibility in the whole temperature range
- Easy mounting in any installation
- High impulse resistance according to ISO 18752 requirements

### APPLICATIONS & FLUIDS



- High pressure power lines for general hydraulics
- Designed for forestry machines booms and harvester heads, harsh environments and severe abrasions
- Mineral oils, vegetable oils and synthetic ester based oils (up to 100°C/212°F), glycols and polyglycols, mineral oils in aqueous emulsion, water

### TECHNICAL DATA

PART. REF.	HOSE SIZE			R.O.D.		O.D.		MAX W.P.		BURST		MIN.BEND		WEIGHT		FITTINGS	
	DN	dash	inch	mm	inch	mm	inch	bar	psi	bar	psi	mm	inch	g/m	lb/ft	Std1	Std2
H10112019*	19	- 12	3/4"	27,7	1,09	31,9	1,26	420	6090	1680	24360	150	5,91	1331	0,89	IP+M01500-12	
H10112025*	25	- 16	1"	34,8	1,37	39,0	1,54	420	6090	1680	24360	210	8,27	1970	1,32	IP+M01500-16	

#### CONTINUOUS SERVICE TEMPERATURE RANGE

-50 °F / 250 °F  
-46 °C / 121 °C

#### MAX OPERATING TEMPERATURE

125 °C, 257 °F

#### TUBE

Oil resistant synthetic rubber

#### REINFORCEMENT

Four high tensile steel spirals

#### COVER

Composite cover with textile reinforcement, realized with high abrasion and ozone resistant synthetic rubber

#### APPLICABLE SPECS

Manuli design, ref. ISO 18752-C

#### TYPE APPROVALS

CU-TR; MSHA

## MASTERTEX

LOW PRESSURE HIGH TEMPERATURE HOSE



### KEY FEATURES

- Long term aging resistance
- Suitability in high temperature applications
- High flexibility
- Wide range of fluid compatibility
- MF2000 Multifit type couplability

### APPLICATIONS & FLUIDS



- Hydraulics: low pressure lines, return lines, drain lines with high temperature fluids
- Mineral oils, synthetic base oils (HS), vegetable and rape seed oils, glycol and polyglycol based oils, oils in aqueous emulsion, water

### TECHNICAL DATA

PART. REF.	HOSE SIZE			R.O.D.		O.D.		MAX W.P.		BURST		MIN.BEND		WEIGHT		FITTINGS	
	DN	dash	inch	mm	inch	mm	inch	bar	psi	bar	psi	mm	inch	g/m	lb/ft	Std1	Std2
H09069006*	6	- 4	1/4"			12,6	0,50	30	430	120	1740	45	1,77	115	0,08	MF+M00830-04	
H09069010*	10	- 6	3/8"			15,8	0,62	30	430	120	1740	75	2,95	160	0,11	MF+M00820-06	
H09069012*	12	- 8	1/2"			19,4	0,76	30	430	120	1740	90	3,54	210	0,14	MF+M00820-08	
H09069016*	16	- 10	5/8"			23,0	0,91	30	430	120	1740	115	4,53	285	0,19	MF+M00820-10	

#### CONTINUOUS SERVICE TEMPERATURE RANGE

-40 °F / 275 °F  
-40 °C / 135 °C

#### TUBE

Oil resistant synthetic rubber

#### REINFORCEMENT

One high resistance textile braid

#### COVER

Environment resistant synthetic rubber

#### APPLICABLE SPECS

Exceed SAE 100 R6; ISO 4079 R6/1TE

#### TYPE APPROVALS

CU-TR

## TWINPOWER 4000

EASY INSTALLATION FOR OEMs



### KEY FEATURES

- Compact hose structure and reduced bend radius
- Isobaric rating for easy selection
- Smooth cover hose ensuring user friendly installation inside the booms
- Unique hose assembly solution for pressure and discharge line on the same body valve
- Reduced installation time compared to two separated assembly hose solutions
- Reduced risk of abrasion of the line inside the booms due to twin hose alignment
- Elimination of clamps to connect the two hose lines, with consequent easyness of insertion
- Warehouse/logistic optimization with reduced codes in stock

### APPLICATIONS & FLUIDS



- Hydraulics: hose range dedicated to aerial lifts, platforms, forklift trucks and telescopic booms applications
- Mineral oils, vegetable oils and synthetic ester based oils, glycols and polyglycols, mineral oils in aqueous emulsion, water

### TECHNICAL DATA

PART. REF.	HOSE SIZE			R.O.D.		O.D.		MAX W.P.		BURST		MIN.BEND		WEIGHT		FITTINGS	
	DN	dash	inch	mm	inch	mm	inch	bar	psi	bar	psi	mm	inch	g/m	lb/ft	Std1	Std2
H01119010*	10	- 6	3/8"	15,4	0,61	18,0	0,71	280	4060	1120	16240	65	2,56	830	0,56	MF+M00120-06	
H01119012*	12	- 8	1/2"	18,5	0,73	21,5	0,85	280	4060	1120	16240	80	3,15	1100	0,74	MF+M00120-08	

#### CONTINUOUS SERVICE TEMPERATURE RANGE

-40 °F / 212 °F  
-40 °C / 100 °C

#### MAX OPERATING TEMPERATURE

121 °C, 250 °F

#### TUBE

Synthetic rubber

#### REINFORCEMENT

Two high tensile steel wire braids

#### COVER

Synthetic rubber with high ozone, abrasion and weather resistance

#### APPLICABLE SPECS

DN 10: ISO 11237 R19; SAE J517 type100R19.  
DN 12: ISO 11237 2SC; EN 857 2SC, SAE J517 type 100R16

#### TYPE APPROVALS

CU-TR

## TWINPOWER 5000

EASY INSTALLATION FOR OEMs



### KEY FEATURES

- Compact hose structure and reduced bend radius
- Isobaric rating exceeding international specifications
- Smooth cover hose ensuring user friendly installation inside the booms
- Unique hose assembly solution for pressure and discharge line on the same body valve
- Reduced installation time compared to two separated assembly hose solutions
- Reduced risk of abrasion of the line inside the booms due to twin hose alignment
- Elimination of clamps to connect the two hose lines, with consequent easyness of insertion
- Higher abrasion resistant and flame retardant MSHA approved cover
- Warehouse/logistic optimization with reduced codes in stock

### APPLICATIONS & FLUIDS



- Hydraulics: hose range dedicated to aerial lifts, platforms, forklift trucks and telescopic booms applications
- Mineral oils, vegetable oils and synthetic ester based oils, glycols and polyglycols, mineral oils in aqueous emulsion, water

### TECHNICAL DATA

PART. REF.	HOSE SIZE			R.O.D.		O.D.		MAX W.P.		BURST		MIN.BEND		WEIGHT		FITTINGS	
	DN	dash	inch	mm	inch	mm	inch	bar	psi	bar	psi	mm	inch	g/m	lb/ft	Std1	Std2
H01120008*	8	- 5	5/16"	12,9	0,51	15,3	0,60	350	5070	1400	20300	55	2,17	682	0,46	MF+M00120-05	
H01120010*	10	- 6	3/8"	15,0	0,59	17,6	0,69	350	5070	1400	20300	65	2,56	830	0,56	MF+M00120-06	
H01120012*	12	- 8	1/2"	18,6	0,73	21,6	0,85	350	5070	1400	20300	80	3,15	1190	0,80	MF+M00120-08	

#### CONTINUOUS SERVICE TEMPERATURE RANGE

-40 °F / 212 °F  
-40 °C / 100 °C

#### MAX OPERATING TEMPERATURE

121 °C, 250 °F

#### TUBE

Synthetic rubber

#### REINFORCEMENT

Two high tensile steel wire braids

#### COVER

Synthetic rubber with high ozone, abrasion and weather resistance

#### APPLICABLE SPECS

Exceed ISO 11237 2SC/R16; EN 857 2SC; SAE J517 type 100R16

#### TYPE APPROVALS

CU-TR; MSHA

## TWINPOWER/PLUS

EASY INSTALLATION FOR OEMs



### KEY FEATURES

- Compact hose structure and reduced bend radius
- Approved with 500.000 flexing impulse cycles (1,33 WP), 125.000 flexing cycles (Manuli testing method)
- Smooth hose cover ensuring user friendly installation inside the booms
- Unique hose assembly solution for pressure and discharge line on the same body valve
- Reduced installation time compared to two separated assembly hose solutions
- Reduced risk of abrasion of the line inside the booms due to twin hose alignment
- Elimination of clamps to connect the two hose lines, with consequent easyness of insertion
- Higher abrasion resistant and flame retardant MSHA approved cover
- Warehouse/logistic optimization with reduced codes in stock

### APPLICATIONS & FLUIDS



- Hydraulics: hose range dedicated to aerial lifts, platforms, forklift trucks and telescopic booms applications
- Mineral oils, vegetable oils and synthetic ester based oils, glycols and polyglycols, mineral oils in aqueous emulsion, water

### TECHNICAL DATA

PART. REF.	HOSE SIZE			R.O.D.		O.D.		MAX W.P.		BURST		MIN.BEND		WEIGHT		FITTINGS	
	DN	dash	inch	mm	inch	mm	inch	bar	psi	bar	psi	mm	inch	g/m	lb/ft	Std1	Std2
H01112A12*	12	- 8	1/2"	18,5	0,73	22,5	0,89	310	4490	1240	17980	80	3,15	1220	0,82	MF+M00120-08	

#### CONTINUOUS SERVICE TEMPERATURE RANGE

-40 °F / 250 °F  
-40 °C / 121 °C

#### MAX OPERATING TEMPERATURE

135 °C, 275 °F

#### TUBE

Synthetic rubber

#### REINFORCEMENT

Two high tensile steel braids

#### COVER

Synthetic rubber with high ozone, abrasion and weather resistance

#### APPLICABLE SPECS

Exceed ISO 11237 2SC/R16; EN 857 2SC; SAE J517 type 100R16

#### TYPE APPROVALS

CU-TR; MSHA

## T°REX

EXTREME TEMPERATURE



### KEY FEATURES

- Extreme high temperature and aging resistance
- High flexibility
- Long service duration

### APPLICATIONS & FLUIDS



- Oil cooling systems, automatic transmissions with very high temperature of the oil, low pressure high temperature applications in hydraulic systems.
- Mineral oils, Synthetic Hydrocarbons oils, glycols and polyglycols (up to 121°C, 250°F)

### TECHNICAL DATA

PART. REF.	HOSE SIZE			R.O.D.		O.D.		MAX W.P.		BURST		MIN.BEND		WEIGHT		FITTINGS	
	DN	dash	inch	mm	inch	mm	inch	bar	psi	bar	psi	mm	inch	g/m	lb/ft	Std1	Std2
H01127031*	31	- 20	1.1/4"			40,7	1,60	43	620	172	2490	203	7,99	925	0,62	MF+	M00110-20TX

#### CONTINUOUS SERVICE TEMPERATURE RANGE

-40 °F / 320 °F  
-40 °C / 160 °C

#### TUBE

Oil resistant synthetic rubber

#### REINFORCEMENT

One high tensile steel wire braid

#### COVER

Synthetic rubber with high ozone, weather and heat resistance

#### APPLICABLE SPECS

Manuli design

#### TYPE APPROVALS

CU-TR



## LUBEMASTER

LUBRICATION LINE



### KEY FEATURES

- Designed for applications with lubrication and transmission fluids
- Compact hose structures for installations in narrow spaces
- Isobaric pressure rating

### APPLICATIONS & FLUIDS



- Lubrication lines, auxiliary systems with transmission oils
- Mineral oils, glycols and polyglycols, transmission fluids (ATF), mineral based greases and lubrication oils.

### TECHNICAL DATA

PART. REF.	HOSE SIZE			R.O.D.		O.D.		MAX W.P.		BURST		MIN.BEND		WEIGHT		FITTINGS	
	DN	dash	inch	mm	inch	mm	inch	bar	psi	bar	psi	mm	inch	g/m	lb/ft	Std1	Std2
H01135006*	6	- 4	1/4"	10,2	0,40	12,0	0,47	210	3040	840	12180	50	1,97	180	0,12	MF+M03300-04	OPF-04
H01135010*	10	- 6	3/8"	14,4	0,57	16,2	0,64	210	3040	840	12180	65	2,56	300	0,20	MF+M03300-06	OPF-06

#### CONTINUOUS SERVICE TEMPERATURE RANGE

-40 °F / 212 °F  
-40 °C / 100 °C

#### MAX OPERATING TEMPERATURE

121 °C, 250 °F

#### TUBE

Synthetic rubber

#### REINFORCEMENT

One high tensile steel braid

#### COVER

Environment resistant synthetic rubber

#### APPLICABLE SPECS

Manuli Design

#### TYPE APPROVALS

CU-TR

## JACKMASTER

EXTREME STATIC PRESSURE



### KEY FEATURES

- High static pressures in remote locations
- Weight-lifting and hydraulic actuations by means of jacking system
- Extreme static pressure
- Tested and approved for specific jacking applications
- Test certificate available upon request
- Standard MF2000 fittings couplability (no special fittings required)
- Halogen-Free hose line

### APPLICATIONS & FLUIDS



- Hydraulic jacking systems
- Mineral oils, vegetable and rape seed oils, glycol and polyglycol based oils, synthetic ester based oils, oils in aqueous emulsion, water

### TECHNICAL DATA

PART. REF.	HOSE SIZE			R.O.D.		O.D.		MAX W.P.		BURST		MIN.BEND		WEIGHT		FITTINGS	
	DN	dash	inch	mm	inch	mm	inch	bar	psi	bar	psi	mm	inch	g/m	lb/ft	Std1	Std2
H01034006*	6	- 4	1/4"	12,7	0,50	14,7	0,58	725	10510	1450	21030	100	3,94	370	0,25	MF+M03400-04	OPF-04
H01034010*	10	- 6	3/8"	15,0	0,59	16,8	0,66	725	10510	1450	21030	127	5,00	395	0,27	MF+M03400-06	OPF-06

#### CONTINUOUS SERVICE TEMPERATURE RANGE

-40 °F / 212 °F  
-40 °C / 100 °C

#### MAX OPERATING TEMPERATURE

121 °C, 250 °F

#### TUBE

Oil resistant synthetic rubber

#### REINFORCEMENT

Two high tensile steel braids

#### COVER

Environment resistant synthetic rubber

#### APPLICABLE SPECS

IJ100 hydraulic jack spec., ISO/CD 16301

#### TYPE APPROVALS

CU-TR



#### Remarks:

Product designed for jacking applications.  
Any different use may reduce service life. Please contact Manuli Hydraulics for more information.

## FIREEND

FIRE SUPPRESSION SYSTEMS



### KEY FEATURES

- SAE 100R1AT and ISO-1SN rated working pressures
- Flame retardant red cover
- Excellent performance for standard hydraulic applications
- Embossed indelible branding
- No skive MF2000 (two-pieces) and MF3000 (one-piece) fittings

### APPLICATIONS & FLUIDS



- Use in fire suppression systems of off-road vehicles, mining equipment, stationary engines. The hose present red cover for easy identification in the fire suppression system
- Mineral oils, vegetable oils and synthetic ester based oils, glycols and polyglycols, mineral oils in aqueous emulsion, water, water based fire extinguishing agents

### TECHNICAL DATA

PART. REF.	HOSE SIZE			R.O.D.		O.D.		MAX W.P.		BURST		MIN.BEND		WEIGHT		FITTINGS	
	DN	dash	inch	mm	inch	mm	inch	bar	psi	bar	psi	mm	inch	g/m	lb/ft	Std1	Std2
H01124006*	6	- 4	1/4"	11,0	0,43	13,0	0,51	225	3260	900	13050	100	3,94	220	0,15	MF+M03400-04	OPF-04
H01124010*	10	- 6	3/8"	15,0	0,59	17,0	0,67	180	2610	720	10440	127	5,00	325	0,22	MF+M03400-06	OPF-06
H01124012*	12	- 8	1/2"	18,1	0,71	20,1	0,79	160	2320	640	9280	178	7,01	410	0,28	MF+M03400-08	OPF-08
H01124019*	19	- 12	3/4"	25,3	1,00	27,9	1,10	105	1520	420	6090	240	9,45	660	0,44	MF+M03400-12	OPF-12
H01124025*	25	- 16	1"	33,1	1,30	35,7	1,41	88	1270	350	5070	300	11,81	980	0,66	MF+M03400-16	

#### CONTINUOUS SERVICE TEMPERATURE RANGE

-40 °F / 212 °F  
-40 °C / 100 °C

#### TUBE

Oil resistant synthetic rubber

#### REINFORCEMENT

One high tensile steel wire braid

#### COVER

Red synthetic rubber with high ozone, abrasion and weather resistance

#### APPLICABLE SPECS

ISO 1436-1SN; SAE J517 type 100R1AT; EN 853-1SN

#### TYPE APPROVALS

MSHA; CU-TR

## CPH/2SC

CABLE PROTECTION HOSE



### KEY FEATURES

- High flexibility
- Low weight
- High-tech manufacturing process
- Easy routing
- Blue flame retardant cover
- MSHA approval of the cover compound

### APPLICATIONS & FLUIDS



- Cable protection hose for mining applications;

### TECHNICAL DATA

PART. REF.	HOSE SIZE			R.O.D.		O.D.		MAX W.P.		BURST		MIN. BEND		WEIGHT		FITTINGS	
	DN	dash	inch	mm	inch	mm	inch	bar	psi	bar	psi	mm	inch	g/m	lb/ft	Std1	Std2
H01033010*	10	- 6	3/8"	15,0	0,59	16,8	0,66							395	0,27	MF+M03400-06	OPF-06
H01033012*	12	- 8	1/2"	18,5	0,73	20,3	0,80							495	0,33	MF+M03400-08	OPF-08
H01033019*	19	- 12	3/4"	25,6	1,01	27,6	1,09							815	0,55	MF+M03400-12	OPF-12

#### CONTINUOUS SERVICE TEMPERATURE RANGE

-40 °F / 212 °F  
-40 °C / 100 °C

#### TUBE

Oil resistant synthetic rubber

#### REINFORCEMENT

Two high tensile steel braids

#### COVER

Blue synthetic rubber with high ozone and weather resistance

#### APPLICABLE SPECS

MANULI® Design

#### TYPE APPROVALS

MSHA; CU-TR

## GOLDENMINE

CHINA COAL MINE HYDRAULICS



### KEY FEATURES

- Very high flow rates in high pressure
- Extreme robustness of the hose structures
- Hose compact dimensions
- Approved with severe fatigue tests
- Superior abrasion resistance
- High ozone and weather resistance
- Flame retardant (MSHA) and antistatic properties
- Biological and mineral oils compatibility
- Crimped InterLock Plus fitting structure

### APPLICATIONS & FLUIDS



- Hydraulics: heavy duty power lines in China coal mines, hydrostatic transmissions in severe environmental conditions, specific installations with tough abrasion conditions, underground and open pit mining.
- Mineral oils, vegetable oils and synthetic ester based oils (up to 100°C/212°F), glycols and polyglycols, mineral oils in aqueous emulsion, water

### TECHNICAL DATA

PART. REF.	HOSE SIZE			R.O.D.		O.D.		MAX W.P.		BURST		MIN. BEND		WEIGHT		FITTINGS	
	DN	dash	inch	mm	inch	mm	inch	bar	psi	bar	psi	mm	inch	g/m	lb/ft	Std1	Std2
H10116063*	63	- 40	2.1/2"	80,6	3,17	84,8	3,34	350	5070	1400	20300	800	31,50	8105	5,45	IP+M01810-40	

#### CONTINUOUS SERVICE TEMPERATURE RANGE

-50 °F / 250 °F  
-46 °C / 121 °C

#### MAX OPERATING TEMPERATURE

125 °C, 257 °F

#### TUBE

Oil resistant synthetic rubber

#### REINFORCEMENT

Six high tensile steel spirals

#### COVER

Synthetic rubber with high abrasion, ozone, weather and heat resistance

#### APPLICABLE SPECS

MT/T98

#### TYPE APPROVALS

MA China; MSHA; CU-TR



#### Remarks:

REMARK: The brand of the hose reports Allowable Working Pressure 50.0 MPa (500 bar), Safety Factor 2,8:1, according to the China norm MT/T98.

## GOLDENGUARD/3000

EMERGENCY HYDRAULIC SYSTEMS & BOP



### KEY FEATURES

- High robustness of the hose structures
- Thermal insulation of the hose with a special cover material
- Long lasting resistance of the cover layer
- Flame retardant properties of the cover
- High ozone and weather resistance

### APPLICATIONS & FLUIDS



- Hydraulics: designed for use in areas where the continuous hydraulic function is required to drive the emergency systems (industrial, marine, off-shore and refineries, defense, mining)
- Flexible hose for hydraulic systems of Blow Out Preventer control lines on drilling rigs
- Mineral oils, glycols and polyglycols, mineral oils in aqueous emulsion

### TECHNICAL DATA

PART. REF.	HOSE SIZE			R.O.D.		O.D.		MAX W.P.		BURST		MIN. BEND		WEIGHT		FITTINGS	
	DN	dash	inch	mm	inch	mm	inch	bar	psi	bar	psi	mm	inch	g/m	lb/ft	Std1	Std2
H11022019*	19	- 12	3/4"	26,9	1,06	32,3	1,27	207	3000	828	12000	180	7,09	1288	0,87	OPK-12	
H11022025*	25	- 16	1"	34,1	1,34	40,1	1,58	207	3000	828	12000	230	9,06	1876	1,26	OPK-16	

#### CONTINUOUS SERVICE TEMPERATURE RANGE

-40 °F / 250 °F  
-40 °C / 121 °C

#### TUBE

High grade NBR oil resistant rubber

#### REINFORCEMENT

Four high tensile steel wire spirals

#### COVER

Red insulant and flame retardant synthetic rubber

#### APPLICABLE SPECS

API 16D Fire Test (pr. 10.1.2), ISO 18752 type C

#### TYPE APPROVALS

DNV-GL; CU-TR; MSHA; API 16D fire test (DNV), LR



#### Remarks:

Refer to GoldenGuard assembling instructions and crimp chart for correct assembling (partial skive required).

## GOLDENGUARD/5000

EMERGENCY HYDRAULIC SYSTEMS & BOP



### KEY FEATURES

- High robustness of the hose structures
- Thermal insulation of the hose with a special cover material
- Long lasting resistance of the cover layer
- Flame retardant properties of the cover
- High ozone and weather resistance

### APPLICATIONS & FLUIDS



- Hydraulics: designed for use in areas where the continuous hydraulic function is required to drive the emergency systems (industrial, marine, off-shore and refineries, defense, mining)
- Flexible hose for hydraulic systems of Blow Out Preventer control lines on drilling rigs
- Mineral oils, glycols and polyglycols, mineral oils in aqueous emulsion

### TECHNICAL DATA

PART. REF.	HOSE SIZE			R.O.D.		O.D.		MAX W.P.		BURST		MIN. BEND		WEIGHT		FITTINGS	
	DN	dash	inch	mm	inch	mm	inch	bar	psi	bar	psi	mm	inch	g/m	lb/ft	Std1	Std2
H11020010*	10	- 6	3/8"	16,7	0,66	20,7	0,81	345	5000	1380	20010	127	5,00	651	0,44	MF+M00910-06	OPK-06
H11020012*	12	- 8	1/2"	20,1	0,79	24,1	0,95	345	5000	1380	20010	150	5,91	820	0,55	MF+M00910-08	OPK-08
H11020016*	16	- 10	5/8"	25,5	1,00	30,9	1,22	345	5000	1380	20010	180	7,09	1490	1,00	IP+M01500-10	
H11020019*	19	- 12	3/4"	29,0	1,14	36,2	1,43	345	5000	1380	20010	240	9,45	2024	1,36	IP+M01500-12	SP+M05400-12
H11020025*	25	- 16	1"	36,0	1,42	44,0	1,73	345	5000	1380	20010	300	11,81	2742	1,84	IP+M01500-16	SP+M05400-16
H11020031*	31	- 20	1.1/4"	47,0	1,85	55,0	2,17	345	5000	1380	20010	420	16,54	4293	2,88	IP+M01600-20	SP+M05500-20
H11020038*	38	- 24	1.1/2"	54,6	2,15	62,6	2,46	345	5000	1380	20010	500	19,69	5531	3,72	IP+M01600-24	SP+M05500-24
H11020051*	51	- 32	2"	68,4	2,69	76,4	3,01	345	5000	1380	20010	630	24,80	7712	5,18	IP+M01800-32	SP+M05500-32

### CONTINUOUS SERVICE TEMPERATURE

**RANGE**  
-40 °F / 250 °F  
-40 °C / 121 °C

### TUBE

High grade NBR oil resistant rubber

### REINFORCEMENT

Multiple plies of high tensile steel wire spirals (DN 16 to 51), 2 wire braids (DN 10 & 12)

### COVER

Red insulant and flame retardant synthetic rubber

### APPLICABLE SPECS

API 16D Fire Test (pr. 10.1.2), DN 10-12: ISO 18752-A; DN 16-51: ISO 18752-C (STD2 fitting) and type C "Plus" (STD1 fitting), ISO 3862 and SAE J517-100R13 performance

### TYPE APPROVALS

DNV-GL; CU-TR; MSHA; API 16D fire test (DNV), LR



### Remarks:

Refer to GoldenGuard assembling instructions and crimp chart for the use of accessories when required:

- STD1 fitting solution: Fire Sleeve & Metal Sleeve over the fitting area are required
- STD2 fitting solution: No accessories required

The STD1 fitting solution has to be selected for the most demanding applications.

DN 10 & 12: Max. continuous temperature 100°C for these wire braided references.



## EMERGENCY HYDRAULIC SYSTEMS & BOP

### KEY FEATURES

- High robustness of the hose structures
- Thermal insulation of the hose with a stainless armour cover
- Long lasting resistance of the cover layer
- Flame retardant properties
- High ozone and weather resistance

### APPLICATIONS & FLUIDS:

- *Hydraulics: designed for use in areas where the continuous hydraulic function is required to drive the emergency systems (industrial, marine, off-shore and refineries, defense, mining);*
- *Flexible hose for hydraulic systems of Blow Out Preventer control lines on drilling rigs;*
- *Mineral oils, glycols and polyglycols, mineral oils in aqueous emulsion.*

HOSE SIZE		MAX W.P.		TEST PRESSURE		BURST PRESSURE		HOSE		FITTING		ACCESSORIES		
		bar	psi	bar	psi	bar	psi	PART. REF.	Insert	Ferrule	Armour guard	Metal Sleeve		
10	-6	3/8"	345	5000	690	10000	1380	20000	ROCKMASTER/2PLUS	H01101010	MF	IM00910-06	JP45G090280099	IO82110-06GA
12	-8	1/2"	345	5000	690	10000	1380	20000	ROCKMASTER/2PLUS	H01101012	MF	IM00910-08	JP45G090320099	IO82110-08GA
16	-10	5/8"	345	5000	690	10000	1380	20000	ROCKMASTER/4SH	H10044016	IP	IM01500-10	JP45G090400099	IO82110-10GA
19	-12	3/4"	345	5000	690	10000	1380	20000	ROCKMASTER/13	H10035019	IP	IM01500-12	JP45G090450099	IO82110-12GA
25	-16	1"	345	5000	690	10000	1380	20000	ROCKMASTER/13	H10035025	IP	IM01500-16	JP45G090500099	IO82110-16GA
31	-20	1-1/4"	345	5000	690	10000	1380	20000	ROCKMASTER/13	H10035032	IP	IM01600-20	JP45G090650099	IO82110-20GA
38	-24	1-1/2"	345	5000	690	10000	1380	20000	ROCKMASTER/13	H10035040	IP	IM01600-24	JP45G090750099	IO82110-24GA
51	-32	2"	345	5000	690	10000	1380	20000	ROCKMASTER/13	H10035051	IP	IM01800-32	JP45G090900099	IO82110-32GA

**CONTINUOUS SERVICE TEMPERATURE RANGE: TUBE:** High grade NBR oil resistant rubber

DN 10, 12:  
-40°C / +100°C  
-40°F / +212°F

DN16-51:  
-40°C / +121°C  
-40°F / +250°F

**REINFORCEMENT:** Multiple plies of high tensile steel wire spirals (DN 16 to 51), 2 wire braids (DN 10, 12)

**COVER:** High abrasion and ozone resistant rubber

**FITTINGS:** MF2000 Interlock Plus crimped fittings (DN 10, 12 Multifit fittings), stainless steel and carbon steel

**EXTERNAL PROTECTION:** stainless steel flexible armour

**APPLICABLE SPECS:** API 16D Fire Test (pr. 10.1.2).

DN 10, 12: ISO 18752-A  
DN 16-51: ISO 18752-C, ISO 3862 and SAE J517 type 100R13 performance

**TYPE APPROVALS:** MSHA, DNV-GL, LR, (API 16D fire test)



**Remark:**  
Refer to GOLDENARMOUR assembling instructions and crimp chart for the correct assembling of the hose.



**Hose assembly branding:**  
The GOLDENARMOUR must report at least the following information in the hose brand:  
 - **inch size - WP 5000 psi** (on the metal sleeve)  
 - **assembling date - assembler identification** (additional tag or on the metal sleeve)



## GOLDENARMOUR MAKE-UP

The GoldenArmour assembly is made up of the following components:

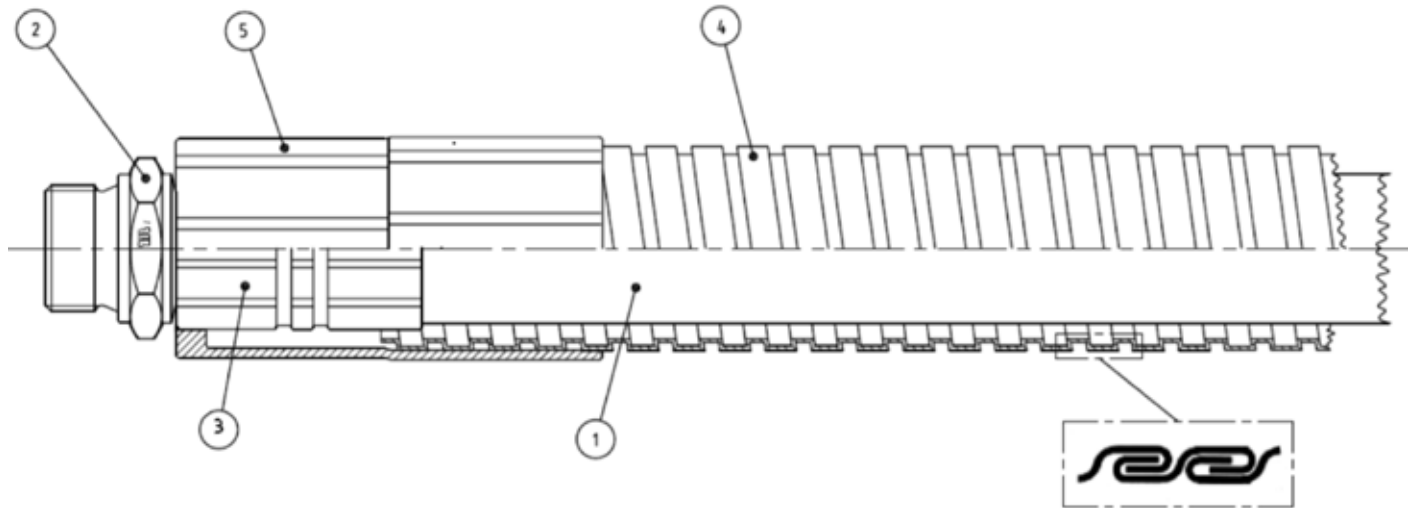

1. Hydraulic hose
2. Hydraulic MF2000 insert type, with additional tail o-ring only for IP fitting solution
3. Hydraulic MF2000 ferrule type
4. External flexible Metal Armour (interlocked flexible metal hose)
5. Metal Sleeve

## ARMOUR JOINING PROCEDURE

Individual pieces of the GoldenArmour metal sleeve can be joined using a dedicated Armour Joint. The procedure for joining the pieces of flexible armour is as follows:

1. Slide the Armour Joint onto the hose.



2. Insert the first piece of flexible armour into the Armour Joint until it reaches the internal stop.



3. Insert the second piece of flexible armour into the other side of the Armour Joint until it also reaches the internal stop.

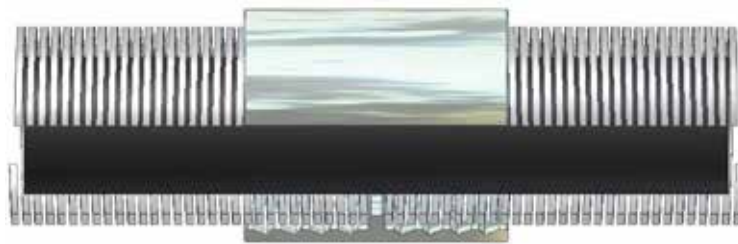

## ACCESSORIES DATASHEETS

## ACCESSORIES



## STAINLESS STEEL ARMOUR GUARD

### METAL FLEXIBLE STRIP WOUND HOSE

PART. REF.	SIZE		MAX OD		MIN. BEND RADIUS		WEIGHT	
	DN	inch	mm	inch	mm	inch	g/m	lb/ft
JP45G090280099	25	1"	32.00	1.26	127	5.00	565	0.38
JP45G090320099	31	1.1/4	36.50	1.44	150	5.91	703	0.47
JP45G090400099	38	1.1/2	44.50	1.75	180	7.09	939	0.63
JP45G090450099	46	1.3/4	51.00	2.01	240	9.45	1118	0.75
JP45G090500099	51	2	57.50	2.26	300	11.81	1301	0.87
JP45G090650099	63	2.1/2	70.00	2.76	420	16.54	1636	1.10
JP45G090750099	76	3	82.50	3.25	500	19.69	1920	1.29
JP45G090900099	89	3.1/2	96.00	3.78	630	24.80	2386	1.60

## ACCESSORIES

### IO821GA

METAL SLEEVE FOR ARMOUR (STAINLESS STEEL)

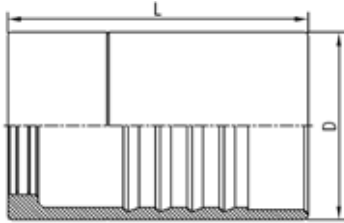

PART. REF.	HOSE BORE			DIMENSIONS mm							
	DN	Dash	inch			D	L				
IO82110-06GA	10	- 6	3/8"			40,5	60				
IO82110-08GA	12	- 8	1/2"			46,8	75				
IO82110-10GA	16	- 10	5/8"			53,2	90				
IO82110-12GA	19	- 12	3/4"			59,5	105				
IO82110-16GA	25	- 16	1"			66	120				
IO82110-20GA	31	- 20	1.1/4"			78,6	135				
IO82110-24GA	38	- 24	1.1/2"			91,5	150				
IO82110-32GA	51	- 32	2"			106,5	165				

## ACCESSORIES

### IO84210

ARMOUR-JOINT

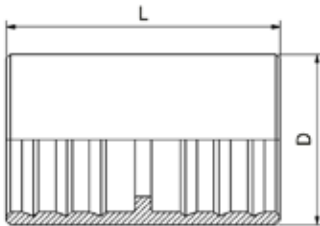

PART. REF.	HOSE BORE			DIMENSIONS mm							
	DN	Dash	inch			D	L				
IO84210-06	10	- 6	3/8"			40,5	65				
IO84210-08	12	- 8	1/2"			46,8	65				
IO84210-10	16	- 10	5/8"			53,2	65				
IO84210-12	19	- 12	3/4"			59,5	70				
IO84210-16	25	- 16	1"			66	75				
IO84210-20	31	- 20	1.1/4"			78,6	95				
IO84210-24	38	- 24	1.1/2"			91,5	105				
IO84210-32	51	- 32	2"			106,5	115				





# FITTINGS



# FITTINGS

## INTRODUCTION

Manuli Hydraulics is globally respected for the breadth and versatility of our hydraulic fittings range. Comprising over 6,000 references, we have fittings to suit most of the common international standards as well as the specific requirements of several of our important OEM customers.

The Manuli Hydraulics fittings range is made up of 3 families: MF2000, MF3000 and Smart Connectors.

The **MF2000** range comprises our core range of two-piece fitting solutions and has over 4,000 references:

**Multifit (MF)** - Simple and cost effective universal solution for wire spiral and wire braid hoses

**Minifit (MN)** - Extremely compact fittings for braided hose (DN6 to DN10)

**Interlock Plus (IP)** - Maximum reliability for very high pressure wire spiral hoses in heavy-duty applications

**Interlock Super (IS)** - High-tech swaged fittings for very large bore wire spiral hose

**Spiral fit (SP)** - No-skive insert for wire spiral hoses and large bore hose

**Xtralock (XL)** - Designed for ultra high pressure hydraulic power lines

**Blastlock (BL)** - Ultra high pressure insert for water-blasting applications

**Pushlock (PL)** - Insert solution for low pressure applications without the need for a swaged ferrule

The **MF3000** range is made up of one-piece fittings for hoses at medium/high pressures:

**One-Piece Flat (OPF)** - No-skive, compact and flat-crimp fittings for wire braid hoses up to 1"

**One-Piece Kompact (OPK)** - No-skive, compact and flat-crimp fittings for wire spiral and wire braid high pressure hoses up to 2"

There are also three types of **Smart Connectors** available:

**RotoFit** - A well-known and patented Manuli Hydraulics solution designed to eliminate hose twist under external torques, which can be a major contributor to premature hose failure.

The additional advantage of RotoFit is that it is a "Direct-to-Hose" and "Direct-to-Port" solution. By eliminating the need for adaptors, the number of possible leak points is reduced.

**EasyFit** - The Manuli "threadless" fittings solution for quick and easy installation of assemblies.

This innovative termination end is fitted with a simple axial push, allowing the hose to self-align and thus improve service life. Maintenance and repair time is also drastically reduced and installation / disconnection in restricted spaces is far easier.

Moreover the "Direct-to-Port" concept eliminates the need for adaptors and the possibility of related leakages.

All EasyFit fittings have an eco-friendly coating treatment for superior corrosion performance.

**FastFit** - A "one plug" connection consisting of a male half integrated onto the hose and then inserted into the female cartridge. This easy and safe operation does not require any tools for assembly and allows easy installation in restricted areas or in complex configurations.

FastFit comes in a wide range of cartridges with direct connection on most standard ports, including BSP, SAE METRIC and NPTF.

# FITTINGS VISUAL INDEX

## CONNECTORS

### TWO PIECE TECHNOLOGY

#### OVERVIEW

MINIFIT



F1

MULTIFIT



F2

INTERLOCK PLUS



F3

INTERLOCK SUPER



F4

XTRALOCK



F5

SPIRALFIT



F6

PUSH-LOCK

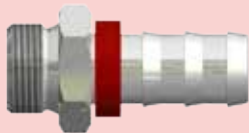

F7

ACCESSORIES

F8

### ONE PIECE TECHNOLOGY

#### OVERVIEW

OPF



F9

OPK

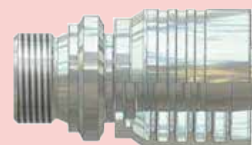

F10

FITTINGS  
F-02



# FITTINGS VISUAL INDEX

## SMART CONNECTORS

### OVERVIEW

EASYFIT



F11

FASTFIT



F12

ROTOFIT



F13

# FITTINGS INDEX

FITTING CODE	SECTION	PAGE
A52013H	12	2
A52032H	11	3
A52053H	12	3
A52192H	11	4
A52193H	12	4
A52283H	12	3
A52302H	11	3
A52323H	12	4
AR520504	13	7
AR580504	13	7
IM01500	3	33
IM01600	3	33
IM01800/IM01810	3	34
IM30510	3	34
IM31210	3	44
IM32510	3	36
IM32810	3	40
IM40812	3	35
IM40842	3	35
IM40892	3	3
IM41613	3	44
IM41643	3	45
IM41692/IM41693	3	45
IM42412	3	38
IM42442	3	39
IM42492	3	39
IM42512	3	37
IM42542	3	37
IM42592	3	38
IM43310	3	40
IM43340	3	41
IM43390	3	41
IM43610	3	42
IM43640	3	43
IM43690	3	43
IM43910	3	46
IM43940	3	46
IM43990	3	47
JO29	3	31
JO29 IS	4	2
L10510	7	1
L20513	7	1
L20543	7	2
L20593	7	2
M..IP..	2	80
M00110-M00120-M00130	2	1
M00310-M00320	2	3
M00820-M00830	2	4
M00910-M00920-M00930	2	1
M01500	3	1

FITTING CODE	SECTION	PAGE
M01600	3	1
M01750	5	1
M01800	5	1
M01800-M01810	3	2
M02400	1	1
M02700	4	1
M02800	4	1
M03300	2	2
M03400	2	2
M03500	2	3
M0811HKR	1	5
M10050	2	82
M10510	2	6
M10610	2	19
M10710	2	5
M11110	2	63
M11210	2	67
M11710	2	71
M11810	2	72
M12410	2	30
M12510	2	21
M12810	2	41
M12H10	11	1
M12H40	11	1
M12H90	11	2
M13010	2	38
M13H10	12	1
M13H40	12	1
M13H90	12	2
M14110R	2	42
M14310	2	39
M14390	2	39
M20511KR	2	8
M20512-20513	2	7
M20514	2	8
M20541KR	2	12
M20542-20543	2	11
M20591KR	2	10
M20592-20593	2	9
M20594	2	10
M20612-20613	2	20
M20711-20712	2	75
M20811HKR	2	14
M20812-20813	2	13
M20841KR	2	18
M20842-20843	2	17
M20882F	2	18
M20891KR	2	16
M20892-20893	2	15
M21013	2	59

FITTINGS  
F 0-4

# FITTINGS INDEX

FITTING CODE	SECTION	PAGE
M21093	2	59
M21312-21313	2	60
M21342-21343	2	62
M21392-21393	2	61
M21512-21513	2	64
M21542-21543	2	66
M21592-21593	2	65
M21612-21613	2	68
M21642-21643	2	70
M21692-M21693	2	69
M21713	2	71
M21813	2	72
M21893	2	73
M22010	2	55
M22040	2	58
M22090	2	57
M22110	2	56
M22140	2	58
M22190	2	57
M22411	2	31
M22441-22443	2	36
M22441KR	2	37
M22491-22493	2	33
M22491KR	2	34
M22512-22513	2	22
M22541KR	2	29
M22542-22543	2	28
M22582F	2	29
M22591KR	2	26
M22592-22593	2	25
M22612	2	40
M22692	2	40
M22711-KR-K	2	24
M22712	2	23
M22812	2	42
M22H10	11	2
M23301P	2	51
M23301S	2	51
M23301T	2	52
M23311	2	43
M23321	2	44
M23331	2	45
M23341	2	46
M23361	2	47
M23371	2	48
M23391	2	49
M23391 LONG DROP	2	50
M23611	2	52
M23641	2	4
M23691	2	53

FITTING CODE	SECTION	PAGE
M23811	2	75
M23911	2	77
M23911CT	2	77
M23941	2	79
M23941CT	2	79
M23991	2	78
M23991CT	2	78
M24011-24012	2	74
M24091	2	74
M24111	2	76
M24141	2	76
M24191	2	76
M24491 LONG DROP	2	35
M24791KR	2	27
M24792-24793	2	26
M27411	2	32
M27411KR	2	32
M30050	3	30
M30510	3	2
M31210	3	18
M32410	3	6
M32510	3	4
M32810	3	11
M33010	3	11
M40812	3	3
M40842	3	4
M40892	3	3
M41243 LONG DROP	3	20
M41293 LONG DROP	3	20
M41612-M41613	3	18
M41642-M41643	3	19
M41692-M41693	3	19
M42411	3	7
M42412	3	7
M42441	3	9
M42442	3	10
M42443	3	10
M42491	3	8
M42492	3	8
M42493	3	9
M42512	3	5
M42542	3	6
M42592	3	5
M43310	3	12
M43320	3	12
M43330	3	13
M43340	3	13
M43390	3	14
M43610	3	15
M43630	3	16

# FITTINGS INDEX

FITTING CODE	SECTION	PAGE
M43640	3	16
M43660	3	17
M43690	3	17
M43710	3	21
M43740	3	21
M43790	3	21
M43910	3	22
M43910CT	3	22
M43920	3	23
M43930	3	23
M43940	3	24
M43940CT	3	24
M43960	3	25
M43970	3	25
M43990	3	26
M43990 LONG DROP	3	27
M43990CT	3	26
M44492 LONG DROP	3	10
M48410	3	27
M48490	3	28
M48510	3	28
M48540	3	29
M48590	3	29
M49510WL	3	30
M52810-M57810	5	2
M53510	5	2
M68510	5	4
M68540	5	5
M68590	5	5
M68610	5	3
M68640	5	4
M68690	5	3
MB3610	4	2
MB8510	4	2
MR10510	13	1
MR11210	13	4
MR11910	13	4
MR12410	13	2
MR12810	13	2
MR20812	13	1
MR21512	13	4
MR22411	13	3
MR22510	13	2
MR22711	13	2
MR23311	13	3
MR30510	13	5
MR30510FK	13	5
MR32810	13	6
MR40812	13	5
MR42410	13	6
MR42510	13	6
MR43310	13	7

FITTING CODE	SECTION	PAGE
MS0511KR	1	2
MS0513	1	2
MS0541KR	1	4
MS0543	1	4
MS0591KR	1	3
MS0593	1	3
MS0813	1	5
MS0841KR	1	7
MS0843	1	7
MS0882F	1	8
MS0891KR	1	6
MS0893	1	6
O20310	2	81
O20910	2	81
O80210	2	82
O80810	2	82
O820	8	1
O82H10	11	4
O83308	8	2
O83607	8	3
O83609	8	2
O88407	8	4
O88507	8	3
OPF10510	9	2
OPF10710	9	2
OPF11110	9	30
OPF11210	9	34
OPF12410	9	16
OPF12510	9	9
OPF12810	9	23
OPF13010	9	21
OPF14110R	9	24
OPF14310	9	22
OPF14390	9	22
OPF20512-OPF20513	9	3
OPF20542-OPF20543	9	5
OPF20592-OPF20593	9	4
OPF20612-OPF20613	9	8
OPF20711	9	38
OPF20812-OPF20813	9	6
OPF20842-OPF20843	9	7
OPF20882F	9	7
OPF20892-OPF20893	9	6
OPF21312-OPF21313	9	29
OPF21392-OPF21393	9	29
OPF21512-OPF21513	9	31
OPF21542-OPF21543	9	33
OPF21592-OPF21593	9	32
OPF21612-OPF21613	9	35
OPF21642-OPF21643	9	37
OPF21692-OPF21693	9	36
OPF22010	9	28

FITTINGS  
F 06

# FITTINGS INDEX

FITTING CODE	SECTION	PAGE
OPF22411	9	17
OPF22441-OPF22443	9	20
OPF22491-OPF22493	9	18
OPF22541KR	9	15
OPF22542-OPF22543	9	14
OPF22582F	9	16
OPF22591KR	9	12
OPF22592-OPF22593	9	11
OPF22612	9	23
OPF22711-KR-K	9	10
OPF22712	9	9
OPF22812	9	24
OPF23311	9	25
OPF23321	9	25
OPF23331	9	26
OPF23341	9	26
OPF23361	9	27
OPF23371	9	27
OPF23391	9	28
OPF23811	9	38
OPF24011	9	37
OPF24111	9	39
OPF24141	9	39
OPF24191	9	39
OPF24491 LONG DROP	9	19
OPF24791KR	9	13
OPF24792-OPF24793 LONG DROP	9	12
OPF3100	9	1
OPK10510	10	1
OPK11110	10	27
OPK11210	10	31
OPK11710	10	33
OPK11810	10	33
OPK12410	10	14
OPK12510	10	8
OPK12810	10	20
OPK13010	10	19
OPK14110R	10	21
OPK14310	10	19
OPK20512-OPK20513	10	2
OPK20542-OPK20543	10	4
OPK20592-OPK20593	10	3

FITTING CODE	SECTION	PAGE
OPK20812-OPK20813	10	5
OPK20842-OPK20843	10	7
OPK20892-OPK20893	10	6
OPK21512-OPK21513	10	28
OPK21542-OPK21543	10	30
OPK21592-OPK21593	10	29
OPK21612-OPK21613	10	31
OPK21642-OPK21643	10	32
OPK21692-OPK21693	10	32
OPK21813	10	33
OPK22411	10	15
OPK22441-OPK22443	10	18
OPK22491-OPK22493	10	16
OPK22541KR	10	13
OPK22542-OPK22543	10	12
OPK22591KR	10	11
OPK22592-OPK22593	10	10
OPK22711-OPK22711KR	10	9
OPK22712	10	8
OPK22812	10	21
OPK23311	10	22
OPK23321	10	22
OPK23331	10	23
OPK23341	10	23
OPK23361	10	24
OPK23371	10	24
OPK23391	10	25
OPK23611	10	25
OPK23641	10	26
OPK23691	10	26
OPK23811	10	34
OPK23911	10	36
OPK23941	10	37
OPK23991	10	36
OPK24011-OPK24012	10	34
OPK24111	10	35
OPK24141	10	35
OPK24191	10	35
OPK24491 LONG DROP	10	17
OPK24791KR	10	12
OPK24792-OPK24793 LONG DROP	10	11
OPK3610	10	1

# FITTINGS - TERMINATION ENDS WORKING PRESSURE

 FITTINGS  
F 0-8

Fitting	Maximum Working Pressure (bar)															
	Hose Size / Dash															
	3/16"	1/4"	5/16"	3/8"	1/2"	5/8"	3/4"	1"	1 1/4"	1 1/2"	2"	2 1/2"	3"	3 1/2"	4"	
	03	04	05	06	08	10	12	16	20	24	32	40	48	56	64	
BSP 60° CONE BS5200 / ISO 8434-6	1/8"-28 350	1/4"-19 500		3/8"-19 460	1/2"-14 430	5/8"-14 350	3/4"-14 350	1"-11 350	1.1/4"-11 350	1.1/2"-11 300	2"-11 300	2.1/2"-11 140	3"-11 105			
JIC 37° CONE ISO 8434-2 / SAE J514		7/16"-20 350	1/2"-20 350	9/16"-18 350	3/4"-16 350	7/8"-14 350	1.1/16"-12 350	1.5/16"-12 280	1.5/8"-12 210	1.7/8"-12 160	2.1/2"-12 125					
ORFS ISO 8434-3 / SAE J1453		9/16"-18 460		11/16"-16 460	13/16"-16 420	1"-14 420	1.3/16"-12 420	1.7/16"-12 420	1.11/16"-12 420	2"-12 350						
NPTF MALE SAE J514 / ASME B1.20.3	1/8"-27 350	1/4"-18 350		3/8"-18 280	1/2"-14 245		3/4"-14 210	1"-11,5 175	1.1/4"-11,5 145	1.1/2"-11,5 145	2"-11,5 145					
NPSM FEMALE SAE J514	1/8"-27 350	1/4"-18 350		3/8"-18 280	1/2"-14 245		3/4"-14 210	1"-11,5 175	1.1/4"-11,5 145	1.1/2"-11,5 145	2"-11,5 145					
SAE 45° CONE SAE J512		7/16"-20 350	1/2"-20 350	5/8"-18 350	3/4"-16 310	7/8"-14 240	1.1/16"-14 240	1.3/8"-12 210								
ISO/SAE CODE 61 FLANGE ISO 6162-1 / SAE J518-1					1/2" 350		3/4" 350	1" 350	1-1/4" 280	1-1/2" 210	2" 210	2-1/2" 175	3" 160	3-1/2" 35	4" 35	
ISO/SAE CODE 62 FLANGE ISO 6162-2 / SAE J518-2					1/2" 420		3/4" 420	1" 420	1-1/4" 420	1-1/2" 420	2" 420	2-1/2" 420	3" 420			
XTRAFRANGE/61 ISO 6162-1 / SAE J518-1 PORT COMPATIBLE								1" 420	1-1/4" 420	1-1/2" 420	2" 420	2-1/2" 420				
XTRAFRANGE/61 ISO 6162-1 / SAE J518-1 PORT COMPATIBLE							3/4" 560	1" 560	1-1/4" 560	1-1/2" 560	2" 450	2-1/2" 350	3" 420			
FLANGE/PLUS ISO 6162-2 / SAE J518-2 PORT COMPATIBLE							3/4" 420	1" 420	1-1/4" 420							
CAT FLANGE ISO 6162-2 / SAE J518-2 PORT COMPATIBLE							3/4" 420	1" 420	1-1/4" 420	1-1/2" 420	2" 420					
METRIC CONE 24° L SERIES ISO 8434-1 / DIN 3865	M12x1,5 415	M14x1,5 400	M16x1,5 350	M18x1,5 330	M22x1,5 275	M26x1,5 250	M30x2 245	M36x2 245	M45x2 220	M52x2 100						
METRIC CONE 24° S SERIES ISO 8434-1 / DIN 3865	M16x1,5 630	M18x1,5 630	M20x1,5 630	M20x1,5 630	M24x1,5 450	M30x2 420	M36x2 385	M42x2 350	M52x2 280							
METRIC CONE 60° LL SERIES DIN 20066							M30x2 63	M38x1,5 63	M45x1,5 63	M52x1,5 63	M65x2 40					
METRIC MULTISEAL DIN 20066	M12x1,5 250	M14x1,5 250	M16x1,5 250	M18x1,5 250	M22x1,5 250	M26x1,5 160										
FRENCH METRIC MILLIMETRIC NF E48-064						M27x1,5 420	M30x1,5 420	M33x1,5 420								
FRENCH GAZ MILLIMETRIC NF E48-064				M20x1,5 630	M24x1,5 630	M30x1,5 420	M36x1,5 420	M45x1,5 420								
JIS METRIC FEMALE 60° CONE (KOMATSU) JIS B8363		M14x1,5 350	M16x1,5 350	M18x1,5 350	M22x1,5 350	M24x1,5 280	M30x1,5 280	M33x1,5 280	M36x1,5 175	M42x2 105						
JIS GAS FEMALE 60° CONE (TOYOTA) JIS B8363		1/4"-19 350		3/8"-19 350	1/2"-14 350		3/4"-14 280	1"-11 280	1.1/4"-11 175	1.1/2"-11 105	2"-11 105					
WASHCLEANER				M22x1,5 420												



**MINIFIT**





FITTING CODE	SECTION	PAGE
M02400	1	1
MS0511KR	1	2
MS0513	1	2
MS0541KR	1	4
MS0543	1	4
MS0591KR	1	3
MS0593	1	3
MS0813	1	5
MS0843	1	7
MS0882F	1	8
MS0893	1	6
M0811HKR	1	5
MS0841KR	1	7
MS0891KR	1	6

## MINIFIT

DN	5	6	8	10	12	16	19	25	31	38	51	60	63	76
Inch	$\frac{3}{16}$ "	$\frac{1}{4}$ "	$\frac{5}{16}$ "	$\frac{3}{8}$ "	$\frac{1}{2}$ "	$\frac{5}{8}$ "	$\frac{3}{4}$ "	1"	$1\frac{1}{4}$ "	$1\frac{1}{2}$ "	2"	$2\frac{3}{8}$ "	$2\frac{1}{2}$ "	3"
Size	-03	-04	-05	-06	-08	-10	-12	-16	-20	-24	-32	-38	-40	-48

## FERRULES

M02400														
--------	--	--	--	--	--	--	--	--	--	--	--	--	--	--

## FITTINGS

BSP														
-----	--	--	--	--	--	--	--	--	--	--	--	--	--	--

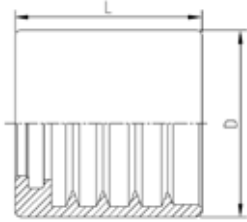

FERRULE

**M02400**

NO-SKIVE FERRULE FOR COMPACT HOSES

PART. REF.	HOSE BORE			DIMENSIONS mm									
	DN	Dash	inch			D	L						
M02400-04	6	- 4	1/4"			18,5	18,5						
M02400-05	8	- 5	5/16"			21,3	19,6						
M02400-06	10	- 6	3/8"			23,8	21,2						

## BS STANDARD CONNECTIONS

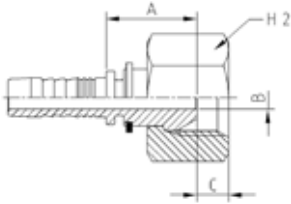

### MS0513

**BSP FEMALE 60° CONE BS5200  
/ISO 8434-6**

PART. REF.	HOSE BORE			Thread		DIMENSIONS mm						
	DN	Dash	inch			T	B	A	C			
MS0513-04-04	6	- 4	1/4"	1/4" - 19		4	15,7	5,4	19			
MS0513-06-06	10	- 6	3/8"	3/8" - 19		7	18,3	6	22			

## BS STANDARD CONNECTIONS

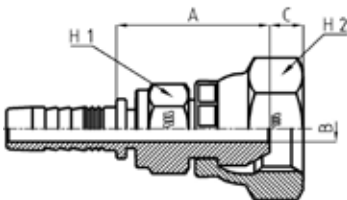

### MS0511KR

**BSP FEMALE 60° CONE - BS5200 / ISO 8434-6**

PART. REF.	HOSE BORE			Thread		DIMENSIONS mm						
	DN	Dash	inch			T	B	A	C			
MS0511-04-04H12KR	6	- 4	1/4"	1/4" - 19		4	23,5	5,2	19			
MS0511-06-06H17KR	10	- 6	3/8"	3/8" - 19		7	26	6	22			

KR:CRIMPED-BACK KOMPACT ROBUST NUT

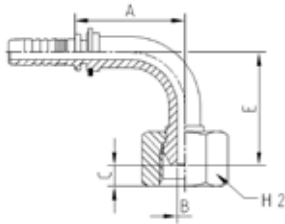

## BS STANDARD CONNECTIONS

### MS0593

90° BSP FEMALE 60° CONE BS5200 /ISO 8434-6

PART. REF.	HOSE BORE			Thread		DIMENSIONS mm						
	DN	Dash	inch			T	B	A	C	E	H2	
MS0593-04-04	6	-4	1/4"	1/4" - 19		4	28,2	5,4	29	19		
MS0593-06-06	10	-6	3/8"	3/8" - 19		7	35,3	6	31,5	22		

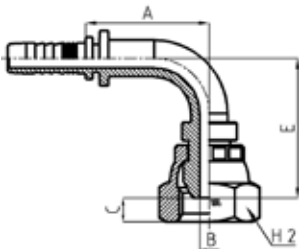

## BS STANDARD CONNECTIONS

### MS0591KR

90° BSP FEMALE SWEPT ELBOW 60° CONE - BS5200 / ISO 8434-6

PART. REF.	HOSE BORE			Thread		DIMENSIONS mm						
	DN	Dash	inch			T	B	A	C	E	H2	
MS0591-04-04KR	6	-4	1/4"	1/4" - 19		4,2	27	5,2	30,5	19		
MS0591-06-06KR	10	-6	3/8"	3/8" - 19		7	34,5	6	37,5	22		

KR:CRIMPED-BACK KOMPACT ROBUST NUT

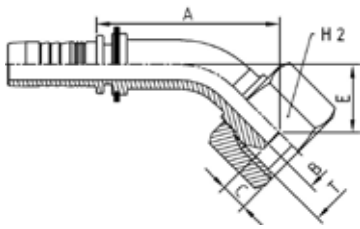

## BS STANDARD CONNECTIONS

### MS0543

45° BSP FEMALE 60° CONE BS5200  
/ ISO 8434-6

PART. REF.	HOSE BORE			Thread		DIMENSIONS mm						
	DN	Dash	inch			T	B	A	C	E	H2	
MS0543-04-04	6	-4	1/4"	1/4" - 19		4	34,7	5,4	14,7	19		
MS0543-06-06	10	-6	3/8"	3/8" - 19		7	41	6	15,3	22		

FITTINGS  
F 1-4

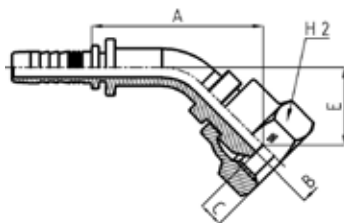

## BS STANDARD CONNECTIONS

### MS0541KR

BSP FEMALE 60° CONE - BS5200 / ISO 8434-6

PART. REF.	HOSE BORE			Thread		DIMENSIONS mm						
	DN	Dash	inch			T	B	A	C	E	H2	
MS0541-04-04KR	6	-4	1/4"	1/4" - 19		4,2	36,5	5,2	16,6	19		
MS0541-06-06KR	10	-6	3/8"	3/8" - 19		7	44,5	6	20	22		

KR:CRIMPED-BACK KOMPACT ROBUST NUT

## BS STANDARD CONNECTIONS

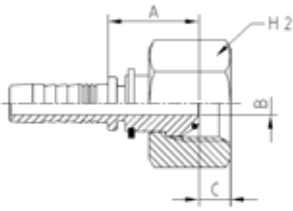

### MS0813

**BSP O-RING FEMALE 60° CONE BS5200  
/ISO 8434-6**

PART. REF.	HOSE BORE			Thread		DIMENSIONS mm						
	DN	Dash	inch			T	B	A	C	H2		
MS0813-04-04	6	- 4	1/4"	1/4" - 19		4	15,7	5,4	19			
MS0813-05-06	8	- 5	5/16"	3/8" - 19		7	18	6	22			
MS0813-06-06	10	- 6	3/8"	3/8" - 19		7	18,3	6	22			

## BS STANDARD CONNECTIONS

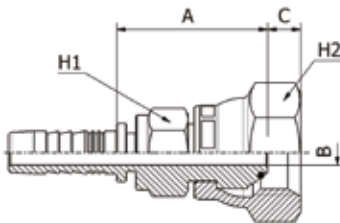

### MS0811HKR

PART. REF.	HOSE BORE			Thread		DIMENSIONS mm						
	DN	Dash	inch			T	B	A	C	H1	H2	
MS0811-04-04H12KR	6	- 4	1/4"	1/4" - 19		4	23,5	5,2	12	19		
MS0811-06-06H17KR	10	- 6	3/8"	3/8" - 19		7	26	6	17	22		

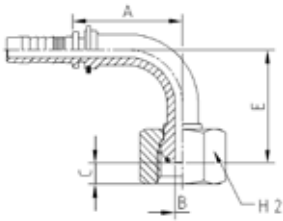

## BS STANDARD CONNECTIONS

### MS0893

90° BSP O-RING FEMALE 60° CONE BS5200  
/ISO 8434-6

PART. REF.	HOSE BORE			Thread		DIMENSIONS mm						
	DN	Dash	inch			T	B	A	C	E	H2	
MS0893-04-04	6	-4	1/4"	1/4" - 19		4	28,2	5,4	29	19		
MS0893-05-06	8	-5	5/16"	3/8" - 19		7	31	6	32,5	22		
MS0893-06-06	10	-6	3/8"	3/8" - 19		7	35,3	6	31,5	22		

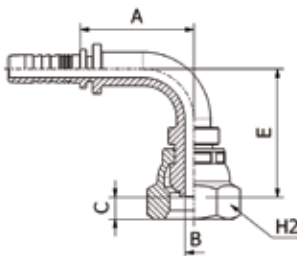

## BS STANDARD CONNECTIONS

### MS0891KR

90° BSP O-RING FEMALE 60° CONE BS5200  
/ISO 8434-6

PART. REF.	HOSE BORE			Thread		DIMENSIONS mm						
	DN	Dash	inch			T	B	A	C	E	H2	
MS0891-04-04KR	6	-4	1/4"	1/4" - 19		4,2	27	5,2	30,5	19		
MS0891-06-06KR	10	-6	3/8"	3/8" - 19		7	34,5	6	37,5	22		

KR:CRIMPED-BACK KOMPACT ROBUST NUT



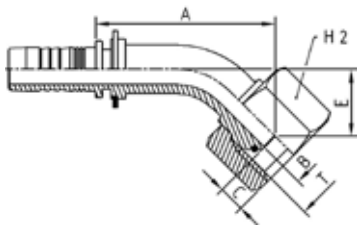

## BS STANDARD CONNECTIONS

### MS0843

**45° BSP O-RING FEMALE 60° CONE BS5200  
/ISO 8434-6**

PART. REF.	HOSE BORE			Thread		DIMENSIONS mm						
	DN	Dash	inch			T	B	A	C	E		
MS0843-04-04	6	-4	1/4"	1/4" - 19		4	34,7	5,4	14,7	19		
MS0843-05-06	8	-5	5/16"	3/8" - 19		7	40,5	6	17	22		
MS0843-06-06	10	-6	3/8"	3/8" - 19		7	41	6	15,3	22		

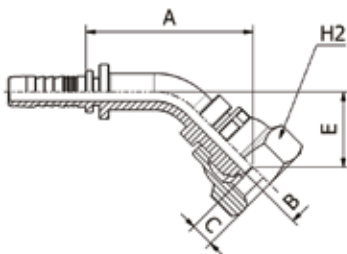

## BS STANDARD CONNECTIONS

### MS0841KR

**45° BSP O-RING FEMALE 60° CONE BS5200  
/ISO 8434-6**

PART. REF.	HOSE BORE			Thread		DIMENSIONS mm						
	DN	Dash	inch			T	B	A	C	E		
MS0841-04-04KR	6	-4	1/4"	1/4" - 19		4,2	36,5	5,2	16,5	19		
MS0841-06-06KR	10	-6	3/8"	3/8" - 19		7	44,5	6	20	22		

KR:CRIMPED-BACK KOMPACT ROBUST NUT

## BS STANDARD CONNECTIONS

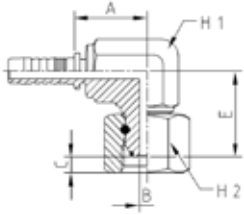

### MS0882F

**90° BSP O-RING FEMALE COMPACT ELBOW 60° CONE BS5200 /ISO 8434-6**

PART. REF.	HOSE BORE			Thread	DIMENSIONS mm							
	DN	Dash	inch		T	B	A	C	E	H1	H2	
MS0882-04-04F	6	-4	1/4"	1/4" - 19	4	18,7	4,1	22	14	19		
MS0882-06-06F	10	-6	3/8"	3/8" - 19	7	21,8	6	27,5	19	22		



**MULTIFIT**



FITTING CODE	SECTION	PAGE
M..IP..	2	80
M00110-M00120-M00130	2	1
M00310-M00320	2	3
M00820-M00830	2	4
M00910-M00920-M00930	2	1
M03300	2	2
M03400	2	2
M03500	2	3
M10050	2	82
M10510	2	6
M10610	2	19
M10710	2	5
M11110	2	63
M11210	2	67
M11710	2	71
M11810	2	72
M12410	2	30
M12510	2	21
M12810	2	41
M13010	2	38
M14110R	2	42
M14310	2	39
M14390	2	39
M20511KR	2	8
M20512-20513	2	7
M20514	2	8
M20541KR	2	12
M20542-20543	2	11
M20591KR	2	10
M20592-20593	2	9
M20594	2	10
M20612-20613	2	20
M20711-20712	2	75
M20811HKR	2	14
M20812-20813	2	13
M20841KR	2	18
M20842-20843	2	17
M20882F	2	18
M20891KR	2	16
M20892-20893	2	15
M21013	2	59
M21093	2	59
M21312-21313	2	60
M21342-21343	2	62
M21392-21393	2	61
M21512-21513	2	64
M21542-21543	2	66
M21592-21593	2	65
M21612-21613	2	68
M21642-21643	2	70
M21692-M21693	2	69
M21713	2	71
M21813	2	72
M21893	2	73
M22010	2	55
M22040	2	58

FITTING CODE	SECTION	PAGE
M22090	2	57
M22110	2	56
M22140	2	58
M22190	2	57
M22411	2	31
M22441-22443	2	36
M22441KR	2	37
M22491-22493	2	33
M22491KR	2	34
M22512-22513	2	22
M22541KR	2	29
M22542-22543	2	28
M22582F	2	29
M22591KR	2	26
M22592-22593	2	25
M22612	2	40
M22692	2	40
M22711-KR-K	2	24
M22712	2	23
M22812	2	42
M23301P	2	51
M23301S	2	51
M23301T	2	52
M23311	2	43
M23321	2	44
M23331	2	45
M23341	2	46
M23361	2	47
M23371	2	48
M23391	2	49
M23391 LONG DROP	2	50
M23611	2	52
M23641	2	4
M23691	2	53
M23811	2	75
M23911	2	77
M23911CT	2	77
M23941	2	79
M23941CT	2	79
M23991	2	78
M23991CT	2	78
M24011-24012	2	74
M24091	2	74
M24111	2	76
M24141	2	76
M24191	2	76
M24491 LONG DROP	2	35
M24791KR	2	27
M24792-24793	2	26
M27411	2	32
M27411KR	2	32
O20310	2	81
O20910	2	81
O80210	2	82
O80810	2	82

## MULTIFIT

DN	5	6	8	10	12	16	19	25	31	38	51	60	63	76	89	102
Inch	3/16"	1/4"	5/16"	3/8"	1/2"	5/8"	3/4"	1"	1 1/4"	1 1/2"	2"	2 3/8"	2 1/2"	3"	3 1/2"	4"
Size	-03	-04	-05	-06	-08	-10	-12	-16	-20	-24	-32	-38	-40	-48	-56	-64

### FERRULES

M00110 / M00120 / M00130																
M00910 / M00920																
M03300																
M03400																
M03500																
M00310																
M00320																
M00820 / M00830																

### FITTINGS

BSP																
SAE (JIC)																
SAE (ORFS)																
SAE																
SAE (NPTF-NPSM)																
SAE FLANGE CODE 61																
SAE FLANGE CODE 62																
DIN STANDPIPE																
DIN METRIC 60° CONE																
DIN METRIC MULTISEAL																
DIN METRIC 24° CONE LIGHT TYPE																
DIN METRIC 24° CONE HEAVY TYPE																
NF (FRENCH MILLIMERIC TYPE)																
NF (FRENCH GAZ TYPE)																
JIS																
ORIGINAL EQUIPMENT CONNECTIONS																
BANJO CONNECTIONS																

FITTINGS F-2-II

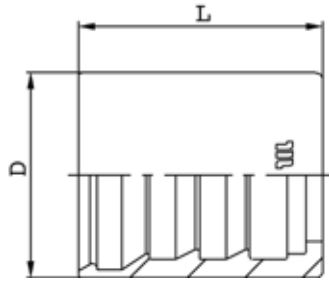

FERRULE

## M00110/M00120/M00130

SKIVE FERRULE FOR WIRE BRAID HOSES

PART. REF.	HOSE BORE			DIMENSIONS mm							
	DN	Dash	inch			D	L				
M00120-03	5	-3	3/16"			17	23,9				
M00120-04	6	-4	1/4"			19,5	28				
M00120-05	8	-5	5/16"			20	28,6				
M00120-06	10	-6	3/8"			23	30				
M00120-08	12	-8	1/2"			26,7	32				
M00120-10	16	-10	5/8"			32	38				
M00120-12	19	-12	3/4"			35,8	41,7				
M00130-16	25	-16	1"			43	47				
M00110-20	31	-20	1.1/4"			50,5	59				
M00110-24	38	-24	1.1/2"			57	70				
M00110-32	51	-32	2"			70	72				

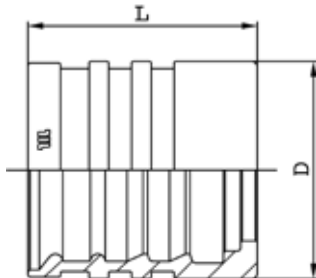

FERRULE

## M00910/M00920/M00930

SKIVE FERRULE FOR WIRE BRAID AND SPIRAL HOSES

PART. REF.	HOSE BORE			DIMENSIONS mm							
	DN	Dash	inch			D	L				
M00910-03	5	-3	3/16"			20,6	26				
M00910-04	6	-4	1/4"			22	30				
M00910-05	8	-5	5/16"			24	31				
M00910-06	10	-6	3/8"			26	33				
M00910-08	12	-8	1/2"			30	34				
M00910-10	16	-10	5/8"			33	39				
M00920-12	19	-12	3/4"			38	40				
M00930-16	25	-16	1"			46	54				
M00920-20	31	-20	1.1/4"			57	60				
M00910-24	38	-24	1.1/2"			65	70				
M00910-32	51	-32	2"			79	72				

FERRULE

**M03300**

NO-SKIVE FERRULE FOR WIRE BRAID HOSES

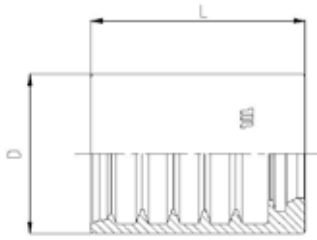

PART. REF.	HOSE BORE			DIMENSIONS mm							
	DN	Dash	inch			D	L				
M03300-03	5	- 3	3/16"			19,2	22				
M03300-04	6	- 4	1/4"			20,5	27,5				
M03300-05	8	- 5	5/16"			22,8	28,5				
M03300-06	10	- 6	3/8"			25	30				

FITTINGS  
F-2-2

FERRULE

**M03400**

NO-SKIVE FERRULE FOR WIRE BRAID HOSES

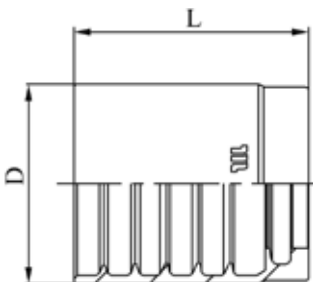

PART. REF.	HOSE BORE			DIMENSIONS mm							
	DN	Dash	inch			D	L				
M03400-03	5	- 3	3/16"			21	23				
M03400-04	6	- 4	1/4"			23	30,1				
M03400-05	8	- 5	5/16"			24	30				
M03400-06	10	- 6	3/8"			26	31,1				
M03400-08	12	- 8	1/2"			29	34				
M03400-10	16	- 10	5/8"			33	37				
M03400-12	19	- 12	3/4"			37	42				
M03400-16	25	- 16	1"			46	50,7				
M03400-20	31	- 20	1.1/4"			59	57,2				
M03400-24	38	- 24	1.1/2"			67	64,8				
M03400-32	51	- 32	2"			80	68,3				
M03400-38	60	- 38	2.3/8"			82,5	69				
M03400-40	63	- 40	2.1/2"			88,2	68,8				
M03400-48	76	- 48	3"			103	75				
M03400-56	89	- 56	3.1/2"			123,4	91				



FERRULE

**M03500**

NO SKIVE FERRULE WIRE SPIRAL

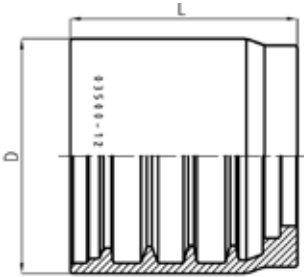

PART. REF.	HOSE BORE			DIMENSIONS mm							
	DN	Dash	inch			D	L				
M03500-06	10	- 6	3/8"			29,5	30,7				
M03500-08	12	- 8	1/2"			33,4	32				
M03500-10	16	- 10	5/8"			37,2	34,8				
M03500-12	19	- 12	3/4"			41,3	40				
M03500-16	25	- 16	1"			49,1	51				

FERRULE

**M00310/M00320**

NO-SKIVE FERRULE FOR TEXTILE BRAID HOSES

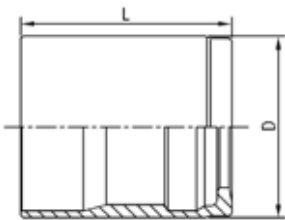

PART. REF.	HOSE BORE			DIMENSIONS mm							
	DN	Dash	inch			D	L				
M00310-03	5	- 3	3/16"			17,5	27				
M00310-04	6	- 4	1/4"			19,3	30				
M00310-05	8	- 5	5/16"			21	32				
M00310-06	10	- 6	3/8"			24	32				
M00310-08	12	- 8	1/2"			28,4	34				
M00310-10	16	- 10	5/8"			33	37				
M00320-12	19	- 12	3/4"			37	43				
M00310-16	25	- 16	1"			43,5	51				
M00310-20	31	- 20	1.1/4"			50	59				

FERRULE

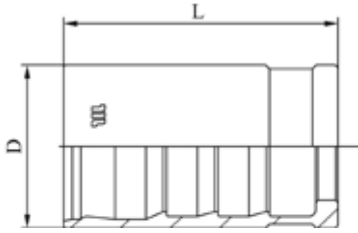

## M00820/M00830

NO-SKIVE FERRULE FOR COMPACT HOSES

FITTINGS F 2-4

PART. REF.	HOSE BORE			DIMENSIONS mm							
	DN	Dash	inch			D	L				
M00820-03	5	- 3	3/16"			14	26,4				
M00830-04	6	- 4	1/4"			18	29,6				
M00830-05	8	- 5	5/16"			19	31,9				
M00820-06	10	- 6	3/8"			22	32,9				
M00820-08	12	- 8	1/2"			26	33,9				
M00820-10	16	- 10	5/8"			29	35,9				
M00820-12	19	- 12	3/4"			33	41,7				
M00820-16	25	- 16	1"			41	49,7				
M00820-20	31	- 20	1.1/4"			48	57				
M00820-24	38	- 24	1.1/2"			55,5	66				
M00820-32	51	- 32	2"			68,6	70				

## BS STANDARD CONNECTIONS

### M10710

#### BSP MALE TAPERED - ISO 7

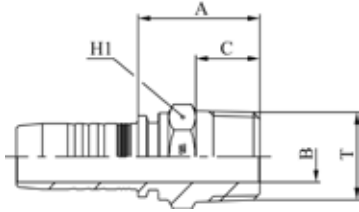

PART. REF.	HOSE BORE			Thread	DIMENSIONS mm							
	DN	Dash	inch		T	B	A	C	H1			
M10710-03-02	5	-3	3/16"	1/8" - 28		4,5	20,5	8	12			
M10710-03-04	5	-3	3/16"	1/4" - 19		4,5	24,5	12	14			
M10710-04-02	6	-4	1/4"	1/8" - 28		4,5	21	8	12			
M10710-04-04	6	-4	1/4"	1/4" - 19		4,5	25	12	14			
M10710-04-06	6	-4	1/4"	3/8" - 19		7	26	12	19			
M10710-04-08	6	-4	1/4"	1/2" - 14		10	29,5	15	22			
M10710-05-04	8	-5	5/16"	1/4" - 19		5,5	25	12	14			
M10710-05-06	8	-5	5/16"	3/8" - 19		7	26,5	12	19			
M10710-05-08	8	-5	5/16"	1/2" - 14		10	30	15	22			
M10710-06-06	10	-6	3/8"	3/8" - 19		7	27	12	19			
M10710-06-08	10	-6	3/8"	1/2" - 14		10	30,5	15	22			
M10710-08-04	12	-8	1/2"	1/4" - 19		4,5	26	12	19			
M10710-08-08	12	-8	1/2"	1/2" - 14		10	31	15	22			
M10710-10-08	16	-10	5/8"	1/2" - 14		10	31	15	22			
M10710-10-12	16	-10	5/8"	3/4" - 14		17	34	17	27			
M10710-12-12	19	-12	3/4"	3/4" - 14		17	35,5	17	27			
M10710-16-12	25	-16	1"	3/4" - 14		17	38	17	32			
M10710-16-16	25	-16	1"	1" - 11		22,5	42	21	36			
M10710-20-20	31	-20	1.1/4"	1.1/4" - 11		28,5	47,5	23	46			
M10710-24-24	38	-24	1.1/2"	1.1/2" - 11		32	50	23	50			
M10710-32-32	51	-32	2"	2" - 11		44	55,5	27	65			

## BS STANDARD CONNECTIONS

### M10510

BSP MALE PARALLEL 60° CONE SEAT - BS5200 / ISO 8434-6

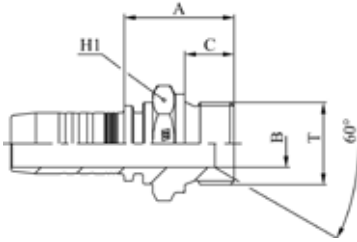

PART. REF.	HOSE BORE			Thread	DIMENSIONS mm							
	DN	Dash	inch		T	B	A	C	H1			
M10510-03-02	5	-3	3/16"	1/8" - 28		3,5	22,5	10	14			
M10510-03-04	5	-3	3/16"	1/4" - 19		5	25	11	19			
M10510-04-02	6	-4	1/4"	1/8" - 28		3,5	22,5	10	14			
M10510-04-04	6	-4	1/4"	1/4" - 19		5	25,5	11	19			
M10510-04-06	6	-4	1/4"	3/8" - 19		8	27	12	22			
M10510-04-08	6	-4	1/4"	1/2" - 14		11	30	14	27			
M10510-05-04	8	-5	5/16"	1/4" - 19		5	26	11	19			
M10510-05-06	8	-5	5/16"	3/8" - 19		8	27,5	12	22			
M10510-06-04	10	-6	3/8"	1/4" - 19		5	26	11	19			
M10510-06-06	10	-6	3/8"	3/8" - 19		8	28	12	22			
M10510-06-08	10	-6	3/8"	1/2" - 14		11	30,5	14	27			
M10510-08-06	12	-8	1/2"	3/8" - 19		8	28	12	22			
M10510-08-08	12	-8	1/2"	1/2" - 14		11	31	14	27			
M10510-08-10	12	-8	1/2"	5/8" - 14		14,5	33	16	30			
M10510-08-12	12	-8	1/2"	3/4" - 14		17	34	16	32			
M10510-10-10	16	-10	5/8"	5/8" - 14		14,5	33	16	30			
M10510-10-12	16	-10	5/8"	3/4" - 14		17	35,5	16	32			
M10510-12-08	19	-12	3/4"	1/2" - 14		11	32	14	27			
M10510-12-12	19	-12	3/4"	3/4" - 14		17	35,5	16	32			
M10510-12-16	19	-12	3/4"	1" - 11		22,5	39,5	19	41			
M10510-16-12	25	-16	1"	3/4" - 14		17	36,5	16	32			
M10510-16-16	25	-16	1"	1" - 11		22,5	41	19	41			
M10510-16-20	25	-16	1"	1.1/4" - 11		28,5	45	20	50			
M10510-20-20	31	-20	1.1/4"	1.1/4" - 11		28,5	46,5	20	50			
M10510-20-24	31	-20	1.1/4"	1.1/2" - 11		33,5	48,5	22	55			
M10510-24-24	38	-24	1.1/2"	1.1/2" - 11		33,5	49,5	22	55			
M10510-32-32	51	-32	2"	2" - 11		46	54	25	70			

## BS STANDARD CONNECTIONS

### M20512/M20513

BSP FEMALE 60° CONE - BS5200 / ISO 12151-6

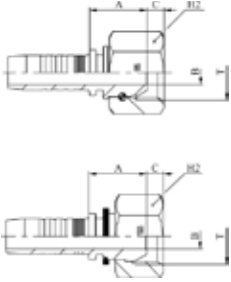

PART. REF.	HOSE BORE			Thread	DIMENSIONS mm							
	DN	Dash	inch		T	B	A	C	H2			
M20512-03-02	5	-3	3/16"	1/8" - 28		3	16	4,4	14			
M20513-03-04	5	-3	3/16"	1/4" - 19		4	16,5	5,4	19			
M20512-04-02	6	-4	1/4"	1/8" - 28		3,1	16,5	4,4	14			
M20513-04-04	6	-4	1/4"	1/4" - 19		4	17	5,4	19			
M20513-04-06	6	-4	1/4"	3/8" - 19		7	19	6	22			
M20513-04-08	6	-4	1/4"	1/2" - 14		9,5	19,5	6,3	27			
M20512-05-04	8	-5	5/16"	1/4" - 19		4,1	17,5	4,2	19			
M20513-05-06	8	-5	5/16"	3/8" - 19		7	19	6	22			
M20513-05-08	8	-5	5/16"	1/2" - 14		9,3	20,5	6,3	27			
M20512-06-04	10	-6	3/8"	1/4" - 19		4,1	18	4,2	19			
M20513-06-06	10	-6	3/8"	3/8" - 19		7	19,5	6	22			
M20513-06-08	10	-6	3/8"	1/2" - 14		9,3	20	6,3	27			
M20512-08-06	12	-8	1/2"	3/8" - 19		7,1	21	6	22			
M20513-08-08	12	-8	1/2"	1/2" - 14		9,3	20,5	6,3	27			
M20512-08-10	12	-8	1/2"	5/8" - 14		12,1	22	10,2	28			
M20512-08-12	12	-8	1/2"	3/4" - 14		15	24,5	9	32			
M20512-10-08	16	-10	5/8"	1/2" - 14		9,8	24	6,5	27			
M20512-10-10	16	-10	5/8"	5/8" - 14		12,5	21,5	10,2	28			
M20512-10-12	16	-10	5/8"	3/4" - 14		15	23	9	32			
M20512-12-08	19	-12	3/4"	1/2" - 14		9,8	25	6,5	27			
M20512-12-12	19	-12	3/4"	3/4" - 14		15	24,5	9	32			
M20512-12-16	19	-12	3/4"	1" - 11		19,8	26	10,5	38			
M20512-16-12	25	-16	1"	3/4" - 14		15	25,5	9	32			
M20512-16-16	25	-16	1"	1" - 11		19,8	27,5	10,5	38			

M20512: THRUST-WIRE NUT / M20513: SLIP-ON NUT

## BS STANDARD CONNECTIONS

### M20514

BSP FEMALE 60° CONE - BS5200 / ISO 12151-6

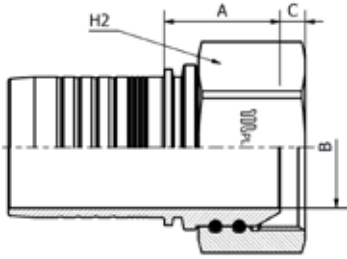

PART. REF.	HOSE BORE			Thread		DIMENSIONS mm						
	DN	Dash	inch			T	B	A	C	H2		
M20514-40-40	63	- 40	2.1/2"	2.1/2"		55,4	52,5	11,5	85			
M20514-48-48	76	- 48	3"	3"		65	57	10,9	100			

## BS STANDARD CONNECTIONS

### M20511KR

BSP FEMALE 60° CONE - BS5200 / ISO 12151-6

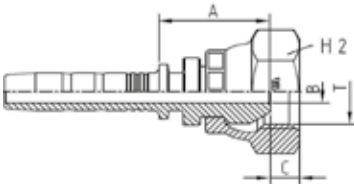

PART. REF.	HOSE BORE			Thread		DIMENSIONS mm						
	DN	Dash	inch			T	B	A	C	H2		
M20511-04-04H12KR	6	- 4	1/4"	1/4" - 19		4	25	5,2	19			
M20511-04-04KR	6	- 4	1/4"	1/4" - 19		4	20	5,2	19			
M20511-04-06H17KR	6	- 4	1/4"	3/8" - 19		7	27	6	22			
M20511-06-06H17KR	10	- 6	3/8"	3/8" - 19		7	27,5	6	22			
M20511-06-06KR	10	- 6	3/8"	3/8" - 19		7	22	6	22			
M20511-06-08H19KR	10	- 6	3/8"	1/2" - 14		9,3	29,5	6,5	27			
M20511-08-06H19KR	12	- 8	1/2"	3/8" - 19		7	29,5	6	22			
M20511-08-08H19KR	12	- 8	1/2"	1/2" - 14		9,3	30	6,5	27			
M20511-08-08KR	12	- 8	1/2"	1/2" - 14		9,3	24	6,5	27			

KR:CRIMPED-BACK KOMPACT ROBUST NUT  
H:FITTINGS WITH COUNTER-HEX.

## BS STANDARD CONNECTIONS

### M20592/M20593

90° BSP FEMALE SWEPT ELBOW 60° CONE - BS5200 / ISO 12151-6

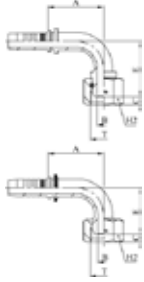

PART. REF.	HOSE BORE			Thread	DIMENSIONS mm							
	DN	Dash	inch		T	B	A	C	E	H2		
M20592-03-02	5	-3	3/16"	1/8" - 28		3	21,5	4,4	26	14		
M20593-03-04	5	-3	3/16"	1/4" - 19		4	29	5,4	29	19		
M20592-04-02	6	-4	1/4"	1/8" - 28		3,1	28,5	4,4	27	14		
M20593-04-04	6	-4	1/4"	1/4" - 19		4	29,5	5,4	29	19		
M20593-04-06	6	-4	1/4"	3/8" - 19		7	29,5	6	31	22		
M20592-05-04	8	-5	5/16"	1/4" - 19		4	26,5	4,1	29,5	19		
M20593-05-06	8	-5	5/16"	3/8" - 19		7	32	6	27,5	22		
M20593-05-08	8	-5	5/16"	1/2" - 14		9,3	36,5	6,3	32	27		
M20592-06-04	10	-6	3/8"	1/4" - 19		4	27	4,1	29,5	19		
M20593-06-06	10	-6	3/8"	3/8" - 19		7	36,5	6	31,5	22		
M20593-06-08	10	-6	3/8"	1/2" - 14		9,3	36,5	6,3	32	27		
M20592-08-06	12	-8	1/2"	3/8" - 19		7,1	45	6	41	22		
M20593-08-08	12	-8	1/2"	1/2" - 14		9,3	45	6,3	36,5	27		
M20592-08-10	12	-8	1/2"	5/8" - 14		12,1	44	10,2	44	28		
M20592-08-12	12	-8	1/2"	3/4" - 14		15	44	9	45,5	32		
M20592-10-08	16	-10	5/8"	1/2" - 14		9,3	53,5	6,5	54,5	27		
M20592-10-10	16	-10	5/8"	5/8" - 14		12,5	53,5	10,2	53,5	28		
M20592-10-12	16	-10	5/8"	3/4" - 14		15	53,5	9	55	32		
M20592-12-08	19	-12	3/4"	1/2" - 14		9,3	45,5	6,5	44	27		
M20592-12-12	19	-12	3/4"	3/4" - 14		15	61,5	9	59,5	32		
M20592-12-16	19	-12	3/4"	1" - 11		19,8	61,5	10,5	62	38		
M20592-16-12	25	-16	1"	3/4" - 14		15	64,5	9	59,5	32		
M20592-16-16	25	-16	1"	1" - 11		19,8	79,5	10,5	76	38		

M20592: THRUST-WIRE NUT / M20593: SLIP-ON NUT

## BS STANDARD CONNECTIONS

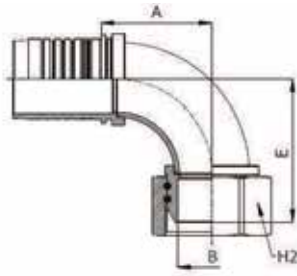

### M20594

90° BSP FEMALE SWEPT ELBOW 60° CONE - BS5200 / ISO 12151-6

PART. REF.	HOSE BORE			Thread		DIMENSIONS mm						
	DN	Dash	inch			T	B	A	C	E	H2	
M20594-40-40	63	- 40	2.1/2"	2.1/2"		55,4	88	11,5	114	85		
M20594-48-48	76	- 48	3"	3"		65	123	10,9	135	100		

BRAZED SOLUTION

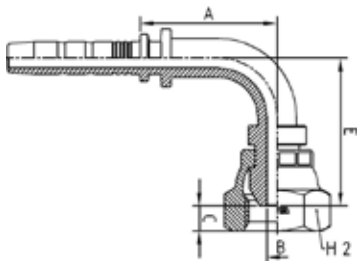

## BS STANDARD CONNECTIONS

### M20591KR

90° BSP FEMALE SWEPT ELBOW 60° CONE - BS5200 / ISO 12151-6

PART. REF.	HOSE BORE			Thread		DIMENSIONS mm						
	DN	Dash	inch			T	B	A	C	E	H2	
M20591-04-04KR	6	- 4	1/4"	1/4" - 19		4,2	28,5	5,2	30,5	19		
M20591-04-06KR	6	- 4	1/4"	3/8" - 19		7	28,5	6	32	22		
M20591-06-06KR	10	- 6	3/8"	3/8" - 19		7	35,5	6	37,5	22		
M20591-06-08KR	10	- 6	3/8"	1/2" - 14		9,3	35,5	6,5	39	27		
M20591-08-06KR	12	- 8	1/2"	3/8" - 19		7	44	6	42	22		
M20591-08-08KR	12	- 8	1/2"	1/2" - 14		9,3	44	6,5	43,5	27		

KR:CRIMPED-BACK KOMPACT ROBUST NUT



## BS STANDARD CONNECTIONS

### M20542/M20543

45° BSP FEMALE SWEPT ELBOW 60° CONE - BS5200 / ISO 12151-6

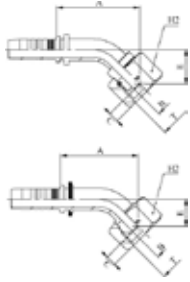

PART. REF.	HOSE BORE			Thread		DIMENSIONS mm						
	DN	Dash	inch			T	B	A	C	E	H2	
M20542-03-02	5	- 3	3/16"	1/8" - 28		3	31	4,4	15	14		
M20543-03-04	5	- 3	3/16"	1/4" - 19		4	35,5	5,4	14,5	19		
M20542-04-02	6	- 4	1/4"	1/8" - 28		3,1	35,5	4,4	14,5	14		
M20543-04-04	6	- 4	1/4"	1/4" - 19		4	36	5,4	15	19		
M20543-04-06	6	- 4	1/4"	3/8" - 19		7	37,5	6	16	22		
M20542-05-04	8	- 5	5/16"	1/4" - 19		4	35,5	4,1	16	19		
M20543-05-06	8	- 5	5/16"	3/8" - 19		7	38	6	13,5	22		
M20543-06-06	10	- 6	3/8"	3/8" - 19		7	42	6	15,5	22		
M20543-06-08	10	- 6	3/8"	1/2" - 14		9,3	42,5	6,3	16	27		
M20542-08-06	12	- 8	1/2"	3/8" - 19		7,1	52	6	20	22		
M20543-08-08	12	- 8	1/2"	1/2" - 14		9,3	49,5	6,3	17	27		
M20542-08-10	12	- 8	1/2"	5/8" - 14		12,1	54,5	10,2	22,5	28		
M20542-08-12	12	- 8	1/2"	3/4" - 14		15	57	9	25	32		
M20542-10-08	16	- 10	5/8"	1/2" - 14		9,3	63,5	6,5	26,5	27		
M20542-10-10	16	- 10	5/8"	5/8" - 14		12,5	63	10,2	26	28		
M20542-10-12	16	- 10	5/8"	3/4" - 14		15	64	9	27	32		
M20542-12-08	19	- 12	3/4"	1/2" - 14		9,3	55,5	6,5	22,5	27		
M20542-12-12	19	- 12	3/4"	3/4" - 14		15	70,5	9	28,5	32		
M20542-12-16	19	- 12	3/4"	1" - 11		19,8	72,5	10,5	30	38		
M20542-16-16	25	- 16	1"	1" - 11		19,8	91	10,5	36,5	38		

M20542: THRUST-WIRE NUT / M20543: SLIP-ON NUT

## BS STANDARD CONNECTIONS

### M20541KR

45° BSP FEMALE SWEPT ELBOW 60° CONE - BS5200 / ISO 12151-6

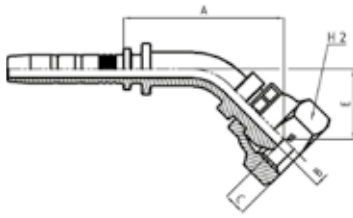

PART. REF.	HOSE BORE			Thread		DIMENSIONS mm						
	DN	Dash	inch			T	B	A	C	E	H2	
M20541-04-04KR	6	- 4	1/4"	1/4" - 19		4,2	38	5,2	16,6	19		
M20541-06-06KR	10	- 6	3/8"	3/8" - 19		7	45,5	6	20	22		
M20541-08-08KR	12	- 8	1/2"	1/2" - 14		9,3	54	6,5	22	27		

KR:CRIMPED-BACK KOMPACT ROBUST NUT

## BS STANDARD CONNECTIONS

### M20812/M20813

BSP O-RING FEMALE 60° CONE - BS5200 / ISO 12151-6

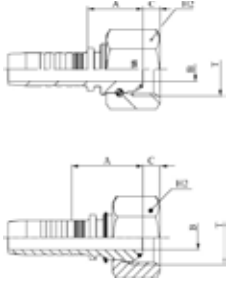

PART. REF.	HOSE BORE			Thread	DIMENSIONS mm							
	DN	Dash	inch		T	B	A	C	H2			
M20813-03-04	5	- 3	3/16"	1/4" - 19		4	16,5	5,4	19			
M20813-04-04	6	- 4	1/4"	1/4" - 19		4	17	5,4	19			
M20813-04-06	6	- 4	1/4"	3/8" - 19		7	19	6	22			
M20812-06-04	10	- 6	3/8"	1/4" - 19		4,1	18	4,1	19			
M20813-06-06	10	- 6	3/8"	3/8" - 19		7	19,5	6	22			
M20813-06-08	10	- 6	3/8"	1/2" - 14		9,3	21	6,3	27			
M20813-08-08	12	- 8	1/2"	1/2" - 14		9,3	20,5	6,3	27			
M20812-10-10	16	- 10	5/8"	5/8" - 14		12,5	22	9,7	28			
M20812-12-12	19	- 12	3/4"	3/4" - 14		15	25	8,5	32			
M20812-16-12	25	- 16	1"	3/4" - 14		15	26	8,5	32			
M20812-16-16	25	- 16	1"	1" - 11		19,8	27,5	10,6	38			
M20812-16-20	25	- 16	1"	1.1/4" - 11		26,1	31	10,5	50			
M20812-20-16	31	- 20	1.1/4"	1" - 11		19,8	29	10,5	38			
M20812-20-20	31	- 20	1.1/4"	1.1/4" - 11		26	31,5	10,5	50			
M20812-20-24	31	- 20	1.1/4"	1.1/2" - 11		32,1	29,5	12,5	60			
M20812-24-20	38	- 24	1.1/2"	1.1/4" - 11		26	31,5	10,5	50			
M20812-24-24	38	- 24	1.1/2"	1.1/2" - 11		32	30,5	12,5	60			
M20812-24-32	38	- 24	1.1/2"	2" - 11		42,1	30	16,1	70			
M20812-32-32	51	- 32	2"	2" - 11		42	32	16,1	70			

M20812: THRUST-WIRE NUT / M20813: SLIP-ON NUT

## BS STANDARD CONNECTIONS

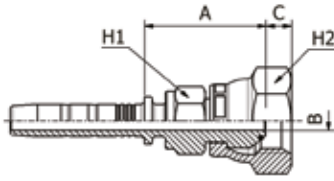

### M20811HKR

PART. REF.	HOSE BORE			Thread		DIMENSIONS mm						
	DN	Dash	inch			T	B	A	C	H1	H2	
M20811-04-04H12KR	6	- 4	1/4"	1/4" - 19		4	25	5,2	12	19		
M20811-04-06H17KR	6	- 4	1/4"	3/8" - 19		7	27	6	17	22		
M20811-06-04H17KR	10	- 6	3/8"	1/4" - 19		4	26	5,2	17	19		
M20811-06-06H17KR	10	- 6	3/8"	3/8" - 19		7	27,5	6	17	22		
M20811-06-08H19KR	10	- 6	3/8"	1/2" - 14		9,3	29,5	6,5	19	27		
M20811-08-06H19KR	12	- 8	1/2"	3/8" - 19		7	29,5	6	19	22		
M20811-08-08H19KR	12	- 8	1/2"	1/2" - 14		9,3	30	5,5	19	22		

## BS STANDARD CONNECTIONS

### M20892/M20893

90° BSP O-RING FEMALE SWEPT ELBOW 60° CONE - BS5200 / ISO  
12151-6

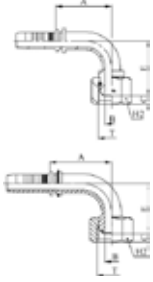

PART. REF.	HOSE BORE			Thread	DIMENSIONS mm						
	DN	Dash	inch		T	B	A	C	E	H2	
M20893-03-04	5	-3	3/16"	1/4" - 19	4	29	5,4	29	19		
M20893-04-04	6	-4	1/4"	1/4" - 19	4	29,5	5,4	29	19		
M20892-06-04	10	-6	3/8"	1/4" - 19	4,1	35,5	4,1	33	19		
M20893-06-06	10	-6	3/8"	3/8" - 19	7	36,5	6	31,5	22		
M20893-08-08	12	-8	1/2"	1/2" - 14	9,3	45	6,3	36,5	27		
M20892-10-10	16	-10	5/8"	5/8" - 14	12,5	53	9,7	55	28		
M20892-12-12	19	-12	3/4"	3/4" - 14	15	61,5	8,5	60	32		
M20892-12-16	19	-12	3/4"	1" - 11	19,8	61,5	10,6	62	38		
M20892-16-12	25	-16	1"	3/4" - 14	15	79,5	8,5	60	32		
M20892-16-16	25	-16	1"	1" - 11	19,8	79,5	10,6	76	38		
M20892-16-20	25	-16	1"	1.1/4" - 11	26,1	79,5	10,5	78,5	50		
M20892-20-16	31	-20	1.1/4"	1" - 11	19,8	79,5	10,6	76	38		
M20892-20-20	31	-20	1.1/4"	1.1/4" - 11	26	90,5	10,5	83,5	50		
M20892-20-24	31	-20	1.1/4"	1.1/2" - 11	32,1	90,5	12,5	84,5	60		
M20892-24-20	38	-24	1.1/2"	1.1/4" - 11	26	95	10,5	90,5	50		
M20892-24-24	38	-24	1.1/2"	1.1/2" - 11	32	108	12,5	98,5	60		
M20892-24-32	38	-24	1.1/2"	2" - 11	42,1	108	16,1	98	70		
M20892-32-32	51	-32	2"	2" - 11	42	131	16,1	110,5	70		

M20892: THRUST-WIRE NUT / M20893: SLIP-ON NUT

## BS STANDARD CONNECTIONS

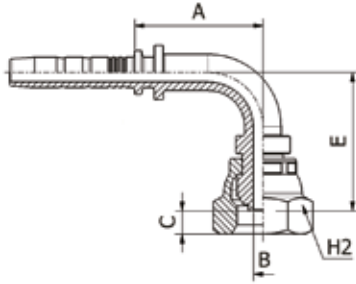

### M20891KR

90° BSP O-RING FEMALE 60° CONE - BS5200 / ISO 12151-6

PART. REF.	HOSE BORE			Thread		DIMENSIONS mm						
	DN	Dash	inch			T	B	A	C	E	H2	
M20891-04-04KR	6	- 4	1/4"	1/4" - 19		4,2	28,5	5,2	30,5	19		
M20891-04-06KR	6	- 4	1/4"	3/8" - 19		7	28,5	6	32	22		
M20891-06-04KR	10	- 6	3/8"	1/4" - 19		4	37,5	5,2	36	19		
M20891-06-06KR	10	- 6	3/8"	3/8" - 19		7	35,5	6	37,5	22		
M20891-06-08KR	10	- 6	3/8"	1/2" - 14		9,3	35,5	6,5	39	27		
M20891-08-06KR	12	- 8	1/2"	3/8" - 19		7	44	6	42	22		
M20891-08-08KR	12	- 8	1/2"	1/2" - 14		9,3	44	5,5	43,5	22		

KR:CRIMPED-BACK KOMPACT ROBUST NUT

## BS STANDARD CONNECTIONS

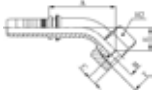
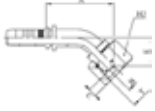

### M20842/M20843

45° BSP O-RING FEMALE SWEPT ELBOW 60° CONE BS5200 / ISO  
12151-6

PART. REF.	HOSE BORE			Thread		DIMENSIONS mm						
	DN	Dash	inch			T	B	A	C	E	H2	
M20843-04-04	6	- 4	1/4"	1/4" - 19		4	36	5,4	14,5	19		
M20843-06-06	10	- 6	3/8"	3/8" - 19		7	42	6	15,5	22		
M20843-08-08	12	- 8	1/2"	1/2" - 14		9,3	49,5	6,3	17	27		
M20842-10-10	16	- 10	5/8"	5/8" - 14		12,5	63,5	9,7	27,5	28		
M20842-12-12	19	- 12	3/4"	3/4" - 14		15	71	8,5	29	32		
M20842-16-12	25	- 16	1"	3/4" - 14		15	79,5	8,5	29	32		
M20842-16-16	25	- 16	1"	1" - 11		19,8	90,5	10,6	35,5	38		
M20842-16-20	25	- 16	1"	1.1/4" - 11		26,1	93	10,5	38	50		
M20842-20-20	31	- 20	1.1/4"	1.1/4" - 11		26	101,5	10,5	39	50		
M20842-20-24	31	- 20	1.1/4"	1.1/2" - 11		32,1	118,5	12,5	40,5	60		
M20842-24-20	38	- 24	1.1/2"	1.1/4" - 11		26	106	10,5	42	50		
M20842-24-24	38	- 24	1.1/2"	1.1/2" - 11		32	118	12,5	45	60		
M20842-24-32	38	- 24	1.1/2"	2" - 11		42,1	117,5	16,1	44,5	70		
M20842-32-32	51	- 32	2"	2" - 11		42	134	16,1	47	70		

M20842: THRUST-WIRE NUT / M20843: SLIP-ON NUT

## BS STANDARD CONNECTIONS

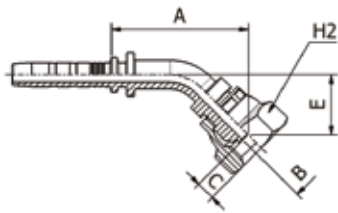

### M20841KR

45° BSP O-RING FEMALE 60° CONE BS5200 / ISO 12151-6

PART. REF.	HOSE BORE			Thread	DIMENSIONS mm							
	DN	Dash	inch		T	B	A	C	E	H2		
M20841-04-04KR	6	- 4	1/4"	1/4" - 19		4,2	38	5,2	16,6	19		
M20841-06-06KR	10	- 6	3/8"	3/8" - 19		7	45,5	6	16,5	22		
M20841-08-08KR	12	- 8	1/2"	1/2" - 14		9,3	54	6,5	22	27		

FITTINGS F 2-18

## BS STANDARD CONNECTIONS

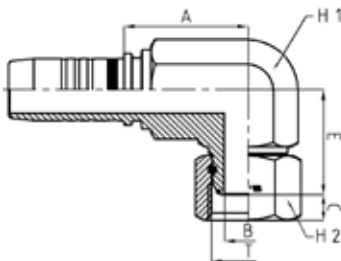

### M20882F

90° BSP O-RING FEMALE COMPACT ELBOW 60° CONE BS5200 / ISO 12151-6 (THRUST-WIRE NUT)

PART. REF.	HOSE BORE			Thread	DIMENSIONS mm							
	DN	Dash	inch		T	B	A	C	E	H1	H2	
M20882-04-04F	6	- 4	1/4"	1/4" - 19		4	20	4,1	22	14	19	
M20882-06-06F	10	- 6	3/8"	3/8" - 19		7	23	6	27,5	19	22	
M20882-08-08F	12	- 8	1/2"	1/2" - 14		9,3	25	6,5	31	22	27	
M20882-10-10F	16	- 10	5/8"	5/8" - 14		12,5	24,5	9,7	32,5	24	28	
M20882-12-12F	19	- 12	3/4"	3/4" - 14		15	37,5	8,5	36	27	32	
M20882-16-16F	25	- 16	1"	1" - 11		20	52	10,6	44	36	38	



## BS STANDARD CONNECTIONS

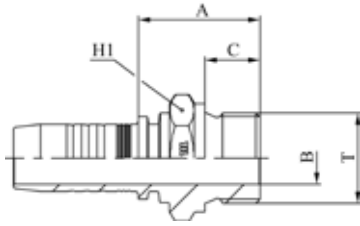

### M10610

#### BSP MALE FLAT SEAT

PART. REF.	HOSE BORE			Thread		DIMENSIONS mm						
	DN	Dash	inch			T	B	A	C	H1		
M10610-04-04	6	- 4	1/4"	1/4" - 19		6	25,5	11	19			
M10610-06-06	10	- 6	3/8"	3/8" - 19		9,5	28	12	22			
M10610-06-08	10	- 6	3/8"	1/2" - 14		13	30,5	14	27			
M10610-08-08	12	- 8	1/2"	1/2" - 14		13	31	14	27			
M10610-10-08	16	- 10	5/8"	1/2" - 14		13	31	14	27			
M10610-12-12	19	- 12	3/4"	3/4" - 14		18	35,5	16	32			

## BS STANDARD CONNECTIONS

### M20612/M20613

BSP FEMALE FLAT SEAT

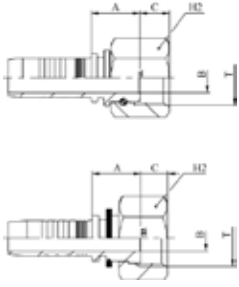

PART. REF.	HOSE BORE			Thread		DIMENSIONS mm						
	DN	Dash	inch			T	B	A	C			
M20613-04-04	6	-4	1/4"	1/4" - 19		4	14,5	7,9	19			
M20613-05-06	8	-5	5/16"	3/8" - 19		7	16	9	22			
M20613-06-06	10	-6	3/8"	3/8" - 19		7	16,5	9	22			
M20613-06-08	10	-6	3/8"	1/2" - 14		9,3	17,5	9,8	27			
M20613-08-08	12	-8	1/2"	1/2" - 14		9,3	18	9,8	27			
M20612-08-12	12	-8	1/2"	3/4" - 14		15	21	11,5	32			
M20612-10-12	16	-10	5/8"	3/4" - 14		15	20,5	11,5	32			
M20612-12-12	19	-12	3/4"	3/4" - 14		15	22	11,5	32			
M20612-12-16	19	-12	3/4"	1" - 11		19,8	23,5	13	38			
M20612-16-16	25	-16	1"	1" - 11		19,8	25	13	38			
M20612-20-20	31	-20	1.1/4"	1.1/4" - 11		26	26	15	50			

M20612: THRUST-WIRE NUT / M20613: SLIP-ON NUT

## SAE STANDARD CONNECTIONS

### M12510

#### JIC MALE 37° CONE - SAE J516 / ISO 12151-5

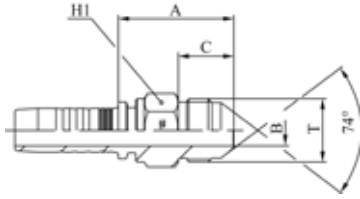

PART. REF.	HOSE BORE			Thread	DIMENSIONS mm							
	DN	Dash	inch		T	B	A	C	H1			
M12510-04-04	6	-4	1/4"	7/16" - 20		4	28	14	12			
M12510-04-05	6	-4	1/4"	1/2" - 20		5,5	29	14	14			
M12510-04-06	6	-4	1/4"	9/16" - 18		7	29	14	17			
M12510-05-04	8	-5	5/16"	7/16" - 20		4	29	14	14			
M12510-05-05	8	-5	5/16"	1/2" - 20		5,5	29	14	14			
M12510-05-06	8	-5	5/16"	9/16" - 18		7	29	14	17			
M12510-06-05	10	-6	3/8"	1/2" - 20		5,5	29,5	14	17			
M12510-06-06	10	-6	3/8"	9/16" - 18		7	29,5	14	17			
M12510-06-08	10	-6	3/8"	3/4" - 16		9,3	34	16,5	19			
M12510-06-10	10	-6	3/8"	7/8" - 14		12,5	38,5	19,5	24			
M12510-08-06	12	-8	1/2"	9/16" - 18		7	32	14	19			
M12510-08-08	12	-8	1/2"	3/4" - 16		9,3	34,5	16,5	19			
M12510-08-10	12	-8	1/2"	7/8" - 14		12,5	39	19,5	24			
M12510-08-12	12	-8	1/2"	1.1/16" - 12		15	43	22	27			
M12510-10-10	16	-10	5/8"	7/8" - 14		12,5	39	19,5	24			
M12510-10-12	16	-10	5/8"	1.1/16" - 12		15	42,5	22	27			
M12510-12-10	19	-12	3/4"	7/8" - 14		12,5	41,5	19,5	27			
M12510-12-12	19	-12	3/4"	1.1/16" - 12		15	44	22	27			
M12510-12-14	19	-12	3/4"	1.3/16" - 12		15	44,5	22,5	32			
M12510-12-16	19	-12	3/4"	1.5/16" - 12		19,8	47	23	34			
M12510-16-12	25	-16	1"	1.1/16" - 12		15	45	22	32			
M12510-16-16	25	-16	1"	1.5/16" - 12		19,8	48	23	34			
M12510-16-20	25	-16	1"	1.5/8" - 12		26	53	24,3	42			
M12510-20-20	31	-20	1.1/4"	1.5/8" - 12		26	53,5	24,3	42			
M12510-20-24	31	-20	1.1/4"	1.7/8" - 12		32	60,5	27,5	50			
M12510-24-24	38	-24	1.1/2"	1.7/8" - 12		32	60,5	27,5	50			
M12510-32-32	51	-32	2"	2.1/2" - 12		42	72	34	65			

## SAE STANDARD CONNECTIONS

### M22512/M22513

JIC FEMALE 37° CONE SEAT - SAE J516 / ISO 12151-5

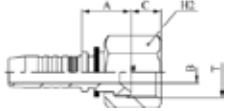
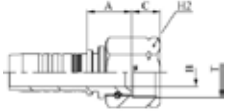

FITTINGS F 2-22

PART. REF.	HOSE BORE			Thread	DIMENSIONS mm							
	DN	Dash	inch		T	B	A	C	H2			
M22513-03-04	5	- 3	3/16"	7/16" - 20		3	15	8	15			
M22512-03-05	5	- 3	3/16"	1/2" - 20		4	15,5	9,1	17			
M22512-04-04	6	- 4	1/4"	7/16" - 20		4	15,5	8,7	17			
M22512-04-05	6	- 4	1/4"	1/2" - 20		4	16	9,1	17			
M22513-04-06	6	- 4	1/4"	9/16" - 18		4	16,5	9,8	19			
M22512-05-04	8	- 5	5/16"	7/16" - 20		4	15,5	8,7	17			
M22512-05-05	8	- 5	5/16"	1/2" - 20		5,5	16	9,1	17			
M22512-05-06	8	- 5	5/16"	9/16" - 18		7	15,5	9,2	19			
M22513-05-08	8	- 5	5/16"	3/4" - 16		5,5	17	10,1	22			
M22512-06-05	10	- 6	3/8"	1/2" - 20		5,5	16,5	9,1	17			
M22512-06-06	10	- 6	3/8"	9/16" - 18		7	16	9,2	19			
M22513-06-08	10	- 6	3/8"	3/4" - 16		7	17,5	10,1	22			
M22513-06-10	10	- 6	3/8"	7/8" - 14		9,3	18	12,4	27			
M22512-08-08	12	- 8	1/2"	3/4" - 16		9,3	20	10,2	22			
M22513-08-10	12	- 8	1/2"	7/8" - 14		9,3	18,5	12,4	27			
M22513-08-12	12	- 8	1/2"	1.1/16" - 12		12,5	22	14,1	32			
M22512-10-10	16	- 10	5/8"	7/8" - 14		12,5	20	12,3	27			
M22513-10-12	16	- 10	5/8"	1.1/16" - 12		12,5	21,5	14,1	32			
M22512-12-08	19	- 12	3/4"	3/4" - 16		9,3	21,5	10,2	22			
M22512-12-10	19	- 12	3/4"	7/8" - 14		12,5	21,5	12,3	27			
M22512-12-12	19	- 12	3/4"	1.1/16" - 12		15	22,5	14,2	32			
M22512-12-14	19	- 12	3/4"	1.3/16" - 12		15	23	14,3	36			
M22512-12-16	19	- 12	3/4"	1.5/16" - 12		19,8	23	15	38			
M22512-16-12	25	- 16	1"	1.1/16" - 12		15	23,5	14,2	32			
M22512-16-16	25	- 16	1"	1.5/16" - 12		19,8	24	15	38			
M22512-16-20	25	- 16	1"	1.5/8" - 12		26	30	16,2	50			
M22512-20-20	31	- 20	1.1/4"	1.5/8" - 12		26	30	16,2	50			
M22512-20-24	31	- 20	1.1/4"	1.7/8" - 12		32	35	18,8	60			
M22512-24-24	38	- 24	1.1/2"	1.7/8" - 12		32	35	18,8	60			
M22512-32-24	51	- 32	2"	1.7/8" - 12		32	37	18,8	60			
M22512-32-32	51	- 32	2"	2.1/2" - 12		44	35,5	24	75			

## SAE STANDARD CONNECTIONS

### M22712

JIC FEMALE 37° CONE SEAT DOUBLE HEXAGON SAE J516 / ISO 12151-5 (THRUST-WIRE NUT)

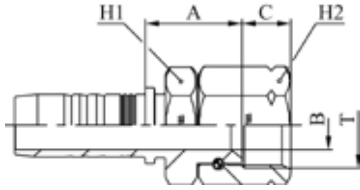

PART. REF.	HOSE BORE			Thread	DIMENSIONS mm							
	DN	Dash	inch		T	B	A	C	H1	H2		
M22712-03-04	5	- 3	3/16"	7/16" - 20		4	20,5	8,7	12	17		
M22712-04-04	6	- 4	1/4"	7/16" - 20		4	21	8,7	12	17		
M22712-04-05	6	- 4	1/4"	1/2" - 20		4	21,5	9,1	12	17		
M22712-04-06	6	- 4	1/4"	9/16" - 18		7	24	9,2	14	19		
M22712-05-05	8	- 5	5/16"	1/2" - 20		5,5	21,5	9,1	14	17		
M22712-05-06	8	- 5	5/16"	9/16" - 18		7	24	9,2	14	19		
M22712-05-08	8	- 5	5/16"	3/4" - 16		9,3	26	10,2	19	22		
M22712-06-04	10	- 6	3/8"	7/16" - 20		4	24,5	8,7	17	17		
M22712-06-05	10	- 6	3/8"	1/2" - 20		5,5	25	9,1	17	17		
M22712-06-06	10	- 6	3/8"	9/16" - 18		7	24,5	9,2	17	19		
M22712-06-08	10	- 6	3/8"	3/4" - 16		9,3	27	10,2	19	22		
M22712-06-10	10	- 6	3/8"	7/8" - 14		12,5	28	12,3	22	27		
M22712-08-06	12	- 8	1/2"	9/16" - 18		7	24,5	9,2	19	19		
M22712-08-08	12	- 8	1/2"	3/4" - 16		9,3	27,5	10,2	19	22		
M22712-08-10	12	- 8	1/2"	7/8" - 14		12,5	28,5	12,3	22	27		
M22712-08-12	12	- 8	1/2"	1.1/16" - 12		14	30	14,2	27	32		
M22712-10-08	16	- 10	5/8"	3/4" - 16		9,3	28,5	10,2	22	22		
M22712-10-10	16	- 10	5/8"	7/8" - 14		12,5	28,5	12,3	22	27		
M22712-10-12	16	- 10	5/8"	1.1/16" - 12		15	30	14,2	27	32		
M22712-12-08	19	- 12	3/4"	3/4" - 16		9,3	30	10,2	27	22		
M22712-12-10	19	- 12	3/4"	7/8" - 14		12,5	30	12,3	27	27		
M22712-12-12	19	- 12	3/4"	1.1/16" - 12		15	31,5	14,2	27	32		
M22712-12-14	19	- 12	3/4"	1.3/16" - 12		15	33	14,3	30	36		
M22712-12-16	19	- 12	3/4"	1.5/16" - 12		19,8	32,5	15	32	38		
M22712-16-12	25	- 16	1"	1.1/16" - 12		12,5	34	14,2	32	32		
M22712-16-16	25	- 16	1"	1.5/16" - 12		19,8	34,5	15	32	38		
M22712-16-20	25	- 16	1"	1.5/8" - 12		26	43	16,2	41	50		
M22712-20-16	31	- 20	1.1/4"	1.5/16" - 12		19,8	36	15	38	38		
M22712-20-20	31	- 20	1.1/4"	1.5/8" - 12		26	43,5	16,2	41	50		
M22712-24-24	38	- 24	1.1/2"	1.7/8" - 12		32	51	18,8	50	60		
M22712-32-32	51	- 32	2"	2.1/2" - 12		44	51,5	24	65	75		

## SAE STANDARD CONNECTIONS

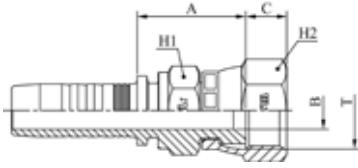

### M22711/M22711KR/M22711K

JIC FEMALE 37° CONE SEAT DOUBLE HEXAGON - SAE J516 / ISO  
12151-5

PART. REF.	HOSE BORE			Thread		DIMENSIONS mm						
	DN	Dash	inch			T	B	A	C	H1	H2	
M22711-03-04K	5	- 3	3/16"	7/16" - 20		4	20	8,9	12	15		
M22711-04-04KR	6	- 4	1/4"	7/16" - 20		4	20,5	8,9	12	15		
M22711-04-05KR	6	- 4	1/4"	1/2" - 20		4	21	9,4	14	17		
M22711-04-06KR	6	- 4	1/4"	9/16" - 18		7	21,5	9,5	14	17		
M22711-06-04KR	10	- 6	3/8"	7/16" - 20		4	21,5	8,9	17	15		
M22711-06-05KR	10	- 6	3/8"	1/2" - 20		4	22	9,4	17	17		
M22711-06-06KR	10	- 6	3/8"	9/16" - 18		7	22	9,5	17	17		
M22711-06-08KR	10	- 6	3/8"	3/4" - 16		9,3	26,5	10,7	19	22		
M22711-08-08KR	12	- 8	1/2"	3/4" - 16		9,3	27	10,7	19	22		
M22711-08-10KR	12	- 8	1/2"	7/8" - 14		9,3	29,5	12,5	22	25		
M22711-08-12KR	12	- 8	1/2"	1.1/16" - 12		15	28,5	14,1	27	32		
M22711-10-08KR	16	- 10	5/8"	3/4" - 16		9,3	28,5	10,7	22	22		
M22711-10-10KR	16	- 10	5/8"	7/8" - 14		12,5	29,5	12,5	22	25		
M22711-10-12KR	16	- 10	5/8"	1.1/16" - 12		15	29	14,1	27	32		
M22711-12-08KR	19	- 12	3/4"	3/4" - 16		9,3	29,5	10,7	27	22		
M22711-12-10KR	19	- 12	3/4"	7/8" - 14		12,5	30,5	12,5	27	25		
M22711-12-12KR	19	- 12	3/4"	1.1/16" - 12		15	30	14,1	27	32		
M22711-12-16	19	- 12	3/4"	1.5/16" - 12		19,8	34,5	15,3	32	38		
M22711-16-12KR	25	- 16	1"	1.1/16" - 12		15	32,5	14,1	32	32		
M22711-16-16	25	- 16	1"	1.5/16" - 12		19,8	35,5	15,3	32	38		
M22711-20-20	31	- 20	1.1/4"	1.5/8" - 12		26	42	16,1	41	50		
M22711-24-24	38	- 24	1.1/2"	1.7/8" - 12		32	46,5	18,6	50	60		
M22711-32-32	51	- 32	2"	2.1/2" - 12		42	50,5	23,5	65	75		

M22711: CRIMPED-BACK NUT / M22711KR and M22711K: CRIMPED-BACK COMPACT NUT

## SAE STANDARD CONNECTIONS

### M22592/M22593

90° JIC FEMALE SWEPT ELBOW 37° CONE SEAT - SAE J516 / ISO  
12151-5

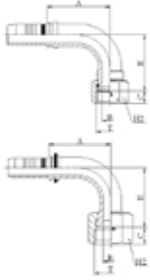

PART. REF.	HOSE BORE			Thread	DIMENSIONS mm							
	DN	Dash	inch		T	B	A	C	E	H2		
M22593-03-04	5	- 3	3/16"	7/16" - 20		3	26	8,5	23,5	15		
M22592-04-04	6	- 4	1/4"	7/16" - 20		4	28,5	8,7	27	17		
M22592-04-05	6	- 4	1/4"	1/2" - 20		4	28,5	9,1	27,5	17		
M22593-04-06	6	- 4	1/4"	9/16" - 18		4	29,5	9,8	28	19		
M22593-04-08	6	- 4	1/4"	3/4" - 16		7	29,5	10	30,5	22		
M22592-05-05	8	- 5	5/16"	1/2" - 20		5,5	31	9,1	28	17		
M22592-05-06	8	- 5	5/16"	9/16" - 18		7	31	9,2	28,5	19		
M22592-06-05	10	- 6	3/8"	1/2" - 20		5,5	30	9,1	26,5	17		
M22592-06-06	10	- 6	3/8"	9/16" - 18		7	35,5	9,2	32,5	19		
M22593-06-08	10	- 6	3/8"	3/4" - 16		7	36,5	10,1	29,5	22		
M22593-06-10	10	- 6	3/8"	7/8" - 14		9,3	36,5	12,4	31,5	27		
M22592-08-06	12	- 8	1/2"	9/16" - 18		7	37	9,2	33	19		
M22592-08-08	12	- 8	1/2"	3/4" - 16		9,3	44	10,2	41	22		
M22593-08-10	12	- 8	1/2"	7/8" - 14		9,3	45	12,4	36	27		
M22593-08-12	12	- 8	1/2"	1.1/16" - 12		12,5	45	14,1	36	32		
M22592-10-10	16	- 10	5/8"	7/8" - 14		12,5	53,5	12,3	52,5	27		
M22593-10-12	16	- 10	5/8"	1.1/16" - 12		12,5	51,5	14,1	50	32		
M22592-12-10	19	- 12	3/4"	7/8" - 14		12,5	55	12,3	52,5	27		
M22592-12-12	19	- 12	3/4"	1.1/16" - 12		15	62	14,2	58	32		
M22592-12-14	19	- 12	3/4"	1.3/16" - 12		15	63	14,3	58	36		
M22592-12-16	19	- 12	3/4"	1.5/16" - 12		19,8	63	15	57,5	38		
M22592-16-16	25	- 16	1"	1.5/16" - 12		19,8	77	15	68,5	38		
M22592-16-20	25	- 16	1"	1.5/8" - 12		26	77,5	16,2	74,5	50		
M22592-20-20	31	- 20	1.1/4"	1.5/8" - 12		26	90,5	16,2	86,5	50		
M22592-20-24	31	- 20	1.1/4"	1.7/8" - 12		32	90,5	18,8	90,5	60		
M22592-24-24	38	- 24	1.1/2"	1.7/8" - 12		32	108	18,8	100,5	60		
M22592-32-32	51	- 32	2"	2.1/2" - 12		44	142	24	137	75		

M22592: THRUST-WIRE NUT / M22593: SLIP-ON NUT

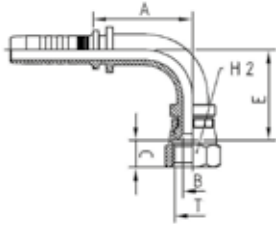

## SAE STANDARD CONNECTIONS

### M22591KR

90° JIC FEMALE SWEPT ELBOW 37° CONE SEAT - SAE J516 / ISO 12151-5

PART. REF.	HOSE BORE			Thread	DIMENSIONS mm						
	DN	Dash	inch		T	B	A	C	E	H2	
M22591-04-04KR	6	- 4	1/4"	7/16" - 20	4,2	28,5	8,9	26	15		
M22591-04-05KR	6	- 4	1/4"	1/2" - 20	4	28,5	9,4	26,5	17		
M22591-06-06KR	10	- 6	3/8"	9/16" - 18	7	35,5	9,5	32	17		
M22591-08-08KR	12	- 8	1/2"	3/4" - 16	9,3	44	10,7	40,5	22		
M22591-10-10KR	16	- 10	5/8"	7/8" - 14	12,5	53,5	12,5	47	25		
M22591-12-12KR	19	- 12	3/4"	1.1/16" - 12	15	62	14,1	57	32		
M22591-16-12KR	25	- 16	1"	1.1/16" - 12	15	62	14,1	57	32		

KR:CRIMPED-BACK KOMPACT ROBUST NUT

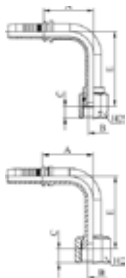

## SAE STANDARD CONNECTIONS

### M24792/M24793

90° JIC FEMALE LONG DROP ELBOW 37° CONE SEAT - SAE J516 / ISO 12151-5

PART. REF.	HOSE BORE			Thread	DIMENSIONS mm						
	DN	Dash	inch		T	B	A	C	E	H2	
M24792-04-04	6	- 4	1/4"	7/16" - 20	4	28,5	8,7	45	17		
M24792-04-05	6	- 4	1/4"	1/2" - 20	4	28,5	9,1	45	17		
M24793-04-06	6	- 4	1/4"	9/16" - 18	4	29,5	9,8	55,5	19		
M24792-06-06	10	- 6	3/8"	9/16" - 18	7	35,5	9,2	55	19		
M24793-06-08	10	- 6	3/8"	3/4" - 16	7	36,5	10,1	61,5	22		
M24792-08-08	12	- 8	1/2"	3/4" - 16	9,3	44	10,2	61	22		
M24793-08-10	12	- 8	1/2"	7/8" - 14	9,3	45	12,4	65	27		
M24792-10-10	16	- 10	5/8"	7/8" - 14	12,5	53,5	12,3	65,5	27		
M24792-12-12	19	- 12	3/4"	1.1/16" - 12	15	62	14,2	94,5	32		
M24792-16-16	25	- 16	1"	1.5/16" - 12	19,8	77,5	15	110	38		
M24792-20-20	31	- 20	1.1/4"	1.5/8" - 12	26	90,5	16,2	129	50		

M24792: THRUST-WIRE NUT - M24793: SLIP-ON NUT



## SAE STANDARD CONNECTIONS

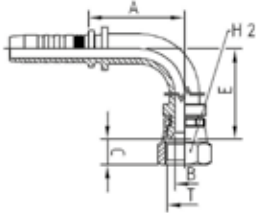

### M24791KR

90° JIC FEMALE LONG DROP ELBOW 37° CONE SEAT - SAE J516 / ISO  
12151-5

PART. REF.	HOSE BORE			Thread	DIMENSIONS mm							
	DN	Dash	inch		T	B	A	C	E	H2		
M24791-04-04KR	6	- 4	1/4"	7/16" - 20		4,2	28,5	8,9	45	15		
M24791-06-06KR	10	- 6	3/8"	9/16" - 18		7	35,5	9,5	55	17		
M24791-08-08KR	12	- 8	1/2"	3/4" - 16		9,3	44	10,7	64	22		
M24791-10-10KR	16	- 10	5/8"	7/8" - 14		12,5	53,5	12,5	70	25		
M24791-12-12KR	19	- 12	3/4"	1.1/16" - 12		15	62	14,1	96	32		

KR:CRIMPED-BACK KOMPACT ROBUST NUT

## SAE STANDARD CONNECTIONS

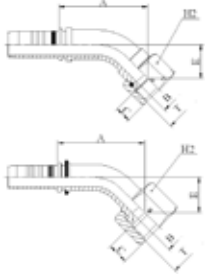

### M22542/M22543

45° JIC FEMALE SWEPT ELBOW 37° CONE SEAT - SAE J516 / ISO  
12151-5

PART. REF.	HOSE BORE			Thread	DIMENSIONS mm						
	DN	Dash	inch	T	B	A	C	E	H2		
M22542-03-04	5	- 3	3/16"	7/16" - 20	4	35	8,7	14,5	17		
M22542-04-04	6	- 4	1/4"	7/16" - 20	4	35,5	8,7	14,5	17		
M22542-04-05	6	- 4	1/4"	1/2" - 20	4	35,5	9,1	14,5	17		
M22543-04-06	6	- 4	1/4"	9/16" - 18	4	35,5	9,8	14	19		
M22542-05-05	8	- 5	5/16"	1/2" - 20	5,5	37,5	9,1	14	17		
M22542-05-06	8	- 5	5/16"	9/16" - 18	7	38	9,2	14,5	19		
M22542-06-06	10	- 6	3/8"	9/16" - 18	7	42	9,2	16,5	19		
M22543-06-08	10	- 6	3/8"	3/4" - 16	7	41	10,1	14	22		
M22543-06-10	10	- 6	3/8"	7/8" - 14	9,3	42,5	12,4	15,5	27		
M22542-08-06	12	- 8	1/2"	9/16" - 18	7	43	9,2	16,5	19		
M22542-08-08	12	- 8	1/2"	3/4" - 16	9,3	52	10,2	20	22		
M22543-08-10	12	- 8	1/2"	7/8" - 14	9,3	49,5	12,4	17	27		
M22543-08-12	12	- 8	1/2"	1.1/16" - 12	12,5	49,5	14,1	17	32		
M22542-10-10	16	- 10	5/8"	7/8" - 14	12,5	62	12,3	25,5	27		
M22543-10-12	16	- 10	5/8"	1.1/16" - 12	12,5	60	14,1	24	32		
M22542-12-08	19	- 12	3/4"	3/4" - 16	9,3	53,5	10,2	20	22		
M22542-12-10	19	- 12	3/4"	7/8" - 14	12,5	63,5	12,3	25	27		
M22542-12-12	19	- 12	3/4"	1.1/16" - 12	15	70	14,2	27,5	32		
M22542-12-14	19	- 12	3/4"	1.3/16" - 12	15	69,5	14,3	27,5	36		
M22542-12-16	19	- 12	3/4"	1.5/16" - 12	19,8	70	15	27,5	38		
M22542-16-12	25	- 16	1"	1.1/16" - 12	15	72,5	14,2	27,5	32		
M22542-16-16	25	- 16	1"	1.5/16" - 12	19,8	84	15	32	38		
M22542-16-20	25	- 16	1"	1.5/8" - 12	26	90	16,2	36	50		
M22542-20-20	31	- 20	1.1/4"	1.5/8" - 12	26	103,5	16,2	41,5	50		
M22542-20-24	31	- 20	1.1/4"	1.7/8" - 12	32	106,5	18,8	44,5	60		
M22542-24-24	38	- 24	1.1/2"	1.7/8" - 12	32	119	18,8	46,5	60		
M22542-32-32	51	- 32	2"	2.1/2" - 12	44	163	24	68	75		

M22542: THRUST-WIRE NUT - M22543: SLIP-ON NUT

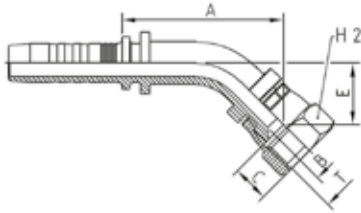

## SAE STANDARD CONNECTIONS

### M22541KR

45° JIC FEMALE SWEPT ELBOW 37° CONE SEAT - SAE J516 / ISO 12151-5

PART. REF.	HOSE BORE			Thread		DIMENSIONS mm						
	DN	Dash	inch			T	B	A	C	E	H2	
M22541-04-04KR	6	- 4	1/4"	7/16" - 20		4,2	34,5	8,9	13,5	15		
M22541-04-05KR	6	- 4	1/4"	1/2" - 20		4	35	9,4	14	17		
M22541-06-06KR	10	- 6	3/8"	9/16" - 18		7	42	9,5	16	17		
M22541-08-08KR	12	- 8	1/2"	3/4" - 16		9,3	52	10,7	20	22		
M22541-10-10KR	16	- 10	5/8"	7/8" - 14		12,5	61	12,5	22,5	25		
M22541-12-12KR	19	- 12	3/4"	1.1/16" - 12		15	69	14,1	26,5	32		

KR:CRIMPED-BACK KOMPACT ROBUST NUT

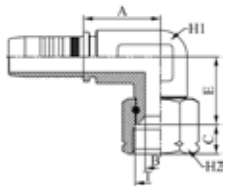

## SAE STANDARD CONNECTIONS

### M22582F

90° JIC FEMALE COMPACT ELBOW 37° CONE SEAT SAE J516 / ISO 12151-5 (THRUST-WIRE NUT)

PART. REF.	HOSE BORE			Thread		DIMENSIONS mm						
	DN	Dash	inch			T	B	A	C	E	H1	H2
M22582-04-04F	6	- 4	1/4"	7/16" - 20		4	20	8,7	20,5	14	17	
M22582-04-06F	6	- 4	1/4"	9/16" - 18		7	20	9,2	21,5	14	19	
M22582-06-06F	10	- 6	3/8"	9/16" - 18		7	23	9,2	24	19	19	
M22582-06-08F	10	- 6	3/8"	3/4" - 16		9,3	26,5	10,2	28	22	22	
M22582-08-08F	12	- 8	1/2"	3/4" - 16		9,3	25	10,2	28	22	22	
M22582-08-10F	12	- 8	1/2"	7/8" - 14		12,5	25	12,3	29	22	27	
M22582-12-12F	19	- 12	3/4"	1.1/16" - 12		15	37,5	14,2	33	27	32	
M22582-16-16F	25	- 16	1"	1.5/16" - 12		20	52	15	40	36	38	

## SAE STANDARD CONNECTIONS

### M12410

ORFS MALE - SAE J516 / ISO 12151-1

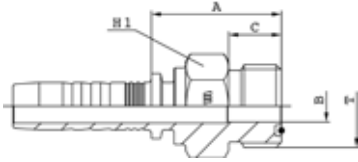

PART. REF.	HOSE BORE			Thread	DIMENSIONS mm						
	DN	Dash	inch		T	B	A	C	H1		
M12410-04-04	6	-4	1/4"	9/16" - 18		4	24	9,8	16		
M12410-04-06	6	-4	1/4"	11/16" - 16		6,7	26,5	11,2	19		
M12410-05-06	8	-5	5/16"	11/16" - 16		6,7	27	11,2	19		
M12410-06-06	10	-6	3/8"	11/16" - 16		6,7	27,5	11,2	19		
M12410-06-08	10	-6	3/8"	13/16" - 16		9,3	30	12,8	22		
M12410-08-06	12	-8	1/2"	11/16" - 16		6,7	29	11,2	22		
M12410-08-08	12	-8	1/2"	13/16" - 16		9,3	30,5	12,8	22		
M12410-08-10	12	-8	1/2"	1" - 14		12,5	35	15,5	27		
M12410-08-12	12	-8	1/2"	1.3/16" - 12		15	37,5	17	32		
M12410-10-08	16	-10	5/8"	13/16" - 16		9,3	30,5	12,8	22		
M12410-10-10	16	-10	5/8"	1" - 14		12,5	34,5	15,5	27		
M12410-10-12	16	-10	5/8"	1.3/16" - 12		15	37,5	17	32		
M12410-12-12	19	-12	3/4"	1.3/16" - 12		15	39	17	32		
M12410-12-16	19	-12	3/4"	1.7/16" - 12		19,8	40,5	17,5	38		
M12410-16-16	25	-16	1"	1.7/16" - 12		19,8	42	17,5	38		
M12410-16-20	25	-16	1"	1.11/16" - 12		26	44	17,5	46		
M12410-20-20	31	-20	1.1/4"	1.11/16" - 12		26	46,5	17,5	46		
M12410-24-24	38	-24	1.1/2"	2" - 12		32	48,5	17,5	55		

## SAE STANDARD CONNECTIONS

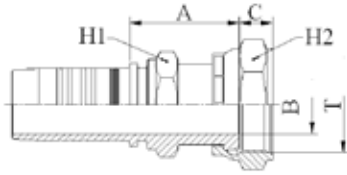

### M22411

ORFS FEMALE - SAE J516 / ISO 12151-1 PULLBACK TYPE  
(CRIMPED BACK-NUT)

PART. REF.	HOSE BORE			Thread	DIMENSIONS mm							
	DN	Dash	inch		T	B	A	C	H1	H2		
M22411-04-04	6	- 4	1/4"	9/16" - 18		4	27,5	8	13	19		
M22411-04-06	6	- 4	1/4"	11/16" - 16		7	30	9,5	16	22		
M22411-04-08	6	- 4	1/4"	13/16" - 16		9,3	35,5	11	19	24		
M22411-05-04	8	- 5	5/16"	9/16" - 18		4	28,5	8	16	19		
M22411-05-06	8	- 5	5/16"	11/16" - 16		7	30,5	9,5	16	22		
M22411-06-04	10	- 6	3/8"	9/16" - 18		4	29	8	16	19		
M22411-06-06	10	- 6	3/8"	11/16" - 16		7	31	9,5	16	22		
M22411-06-08	10	- 6	3/8"	13/16" - 16		9,3	36,5	11	19	24		
M22411-08-06	12	- 8	1/2"	11/16" - 16		7	32	9,5	19	22		
M22411-08-08	12	- 8	1/2"	13/16" - 16		9,3	37	11	19	24		
M22411-08-10	12	- 8	1/2"	1" - 14		11,5	39	13,5	24	30		
M22411-08-12	12	- 8	1/2"	1.3/16" - 12		13,9	44	14,5	28	36		
M22411-10-08	16	- 10	5/8"	13/16" - 16		9,3	37	11	24	24		
M22411-10-10	16	- 10	5/8"	1" - 14		11,5	39	13,5	24	30		
M22411-10-12	16	- 10	5/8"	1.3/16" - 12		13,9	44	14,5	28	36		
M22411-12-10	19	- 12	3/4"	1" - 14		11,5	41,5	13,5	28	30		
M22411-12-12	19	- 12	3/4"	1.3/16" - 12		13,9	45,5	14,5	28	36		
M22411-12-16	19	- 12	3/4"	1.7/16" - 12		19,8	48,5	15	36	41		
M22411-16-12	25	- 16	1"	1.3/16" - 12		13,9	48	13,5	36	36		
M22411-16-16	25	- 16	1"	1.7/16" - 12		19,8	49,5	15	36	41		
M22411-16-20	25	- 16	1"	1.11/16" - 12		26	49,5	14,8	41	50		
M22411-20-20	31	- 20	1.1/4"	1.11/16" - 12		26	52	14,8	41	50		
M22411-20-24	31	- 20	1.1/4"	2" - 12		32	54	15,8	50	60		
M22411-24-24	38	- 24	1.1/2"	2" - 12		32	54	15,8	50	60		

## SAE STANDARD CONNECTIONS

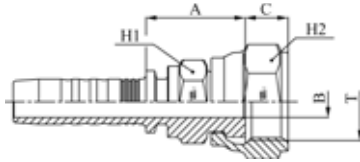

### M27411

ORFS FEMALE - SAE J516 / ISO 12151-1 SHORT TYPE  
(CRIMPED BACK-NUT)

PART. REF.	HOSE BORE			Thread		DIMENSIONS mm						
	DN	Dash	inch			T	B	A	C	H1	H2	
M27411-04-04	6	-4	1/4"	9/16" - 18		4	20,5	8	13	19		
M27411-04-06	6	-4	1/4"	11/16" - 16		7	22	9,5	16	22		
M27411-05-06	8	-5	5/16"	11/16" - 16		7	25,5	9,5	16	22		
M27411-06-06	10	-6	3/8"	11/16" - 16		7	26	9,5	16	22		
M27411-06-08	10	-6	3/8"	13/16" - 16		9,3	26,5	11	19	24		
M27411-08-08	12	-8	1/2"	13/16" - 16		9,3	26,5	11	19	24		
M27411-08-10	12	-8	1/2"	1" - 14		11,5	27,5	12,5	24	30		
M27411-08-12	12	-8	1/2"	1.3/16" - 12		13,9	31	13,5	28	36		
M27411-10-10	16	-10	5/8"	1" - 14		11,5	28	12,5	24	30		
M27411-10-12	16	-10	5/8"	1.3/16" - 12		13,9	31	13,5	28	36		
M27411-12-12	19	-12	3/4"	1.3/16" - 12		13,9	32,5	13,5	28	36		
M27411-16-16	25	-16	1"	1.7/16" - 12		19,8	36,5	13,5	36	41		

## SAE STANDARD CONNECTIONS

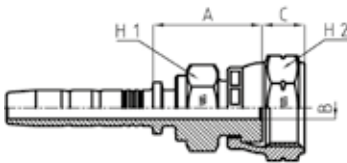

### M27411KR

ORFS FEMALE - SAE J516 / ISO 12151-1 SHORT TYPE

PART. REF.	HOSE BORE			Thread		DIMENSIONS mm						
	DN	Dash	inch			T	B	A	C	H1	H2	
M27411-04-04KR	6	-4	1/4"	9/16" - 18		4	20,5	8	14	17		
M27411-06-06KR	10	-6	3/8"	11/16" - 16		7	23	9,5	17	22		
M27411-08-08KR	12	-8	1/2"	13/16" - 16		9,3	27	11	19	24		

KR:CRIMPED-BACK KOMPACT ROBUST NUT

## SAE STANDARD CONNECTIONS

### M22491/M22493

#### 90° ORFS FEMALE SWEPT ELBOW - SAE J516 / ISO 12151-1

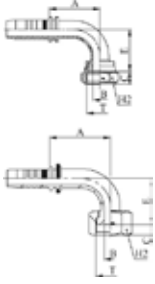

PART. REF.	HOSE BORE			Thread	DIMENSIONS mm							
	DN	Dash	inch		T	B	A	C	E	H2		
M22493-04-04	6	-4	1/4"	9/16" - 18		4	27,5	8,2	22	17		
M22493-04-06	6	-4	1/4"	11/16" - 16		7	27,5	9,5	22	22		
M22493-05-06	8	-5	5/16"	11/16" - 16		7	32	9,5	23	22		
M22491-06-04	10	-6	3/8"	9/16" - 18		4	28	8	23	19		
M22493-06-06	10	-6	3/8"	11/16" - 16		6	30	9,5	24	22		
M22493-06-08	10	-6	3/8"	13/16" - 16		9,3	30	11	26,5	24		
M22491-08-06	12	-8	1/2"	11/16" - 16		7	30	9,5	24,5	22		
M22493-08-08	12	-8	1/2"	13/16" - 16		9	40,5	11	30	24		
M22493-08-10	12	-8	1/2"	1" - 14		11,5	40	13,5	30,5	30		
M22493-08-12	12	-8	1/2"	1.3/16" - 12		13,9	39,5	14,5	37,5	36		
M22491-10-08	16	-10	5/8"	13/16" - 16		9,3	41	11	34	24		
M22493-10-10	16	-10	5/8"	1" - 14		11,5	48	13,5	37,5	30		
M22491-10-10032	16	-10	5/8"	1" - 14		11	42	7,5	32	30		
M22493-10-12	16	-10	5/8"	1.3/16" - 12		13,9	48	14,5	41	36		
M22491-12-10	19	-12	3/4"	1" - 14		11,5	49	12,5	38,5	30		
M22493-12-12	19	-12	3/4"	1.3/16" - 12		13,9	56,5	14,5	48	36		
M22493-12-16	19	-12	3/4"	1.7/16" - 12		19,8	56,5	14,8	47,5	41		
M22491-16-12	25	-16	1"	1.3/16" - 12		13,9	57,5	13,5	48	36		
M22493-16-16	25	-16	1"	1.7/16" - 12		19,8	71,5	14,8	56	41		
M22493-16-20	25	-16	1"	1.11/16" - 12		26	71,5	14,8	58,5	50		
M22493-20-20	31	-20	1.1/4"	1.11/16" - 12		26	83	14,8	66	50		
M22493-24-24	38	-24	1.1/2"	2" - 12		32	102	14,8	79,5	60		

M22491: CRIMPED BACK-NUT / M22493: SLIP-ON NUT

## SAE STANDARD CONNECTIONS

### M22491KR

90° ORFS FEMALE SWEPT ELBOW - SAE J516 / ISO 12151-1

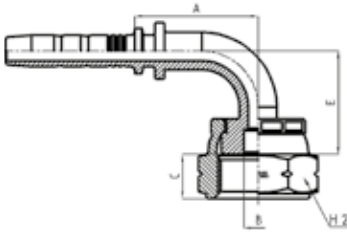

PART. REF.	HOSE BORE			Thread	DIMENSIONS mm						
	DN	Dash	inch		T	B	A	C	E	H2	
M22491-04-04KR	6	- 4	1/4"	9/16" - 18	4,2	54	8	22	17		
M22491-04-06KR	6	- 4	1/4"	11/16" - 16	6	26,3	9,5	22	22		
M22491-06-06KR	10	- 6	3/8"	11/16" - 16	6	29	9,5	24	22		
M22491-06-08KR	10	- 6	3/8"	13/16" - 16	9	35,5	11	28,5	24		
M22491-08-08KR	12	- 8	1/2"	13/16" - 16	9	40,5	11	30,5	24		

KR:CRIMPED-BACK KOMPACT ROBUST NUT



## SAE STANDARD CONNECTIONS

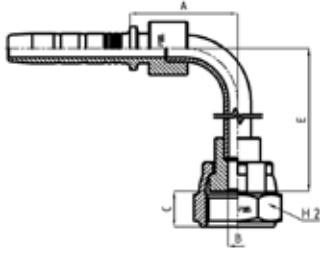

### M24491 LONG DROP

90° ORFS FEMALE LONG DROP ELBOW - SAE J516 / ISO 12151-1  
(CRIMPED-BACK NUT)

PART. REF.	HOSE BORE			Thread		DIMENSIONS mm						
	DN	Dash	inch			T	B	A	C	E	H2	
M24491-04-04	6	- 4	1/4"	9/16" - 18		4,4	25	8	46	17		
M24491-04-06	6	- 4	1/4"	11/16" - 16		7	26,5	9,5	53,5	22		
M24491-05-06	8	- 5	5/16"	11/16" - 16		6,7	31,5	9,5	54	22		
M24491-06-06	10	- 6	3/8"	11/16" - 16		6,7	32	9,5	54	22		
M24491-06-08	10	- 6	3/8"	13/16" - 16		6,7	32	11	54	24		
M24491-08-08	12	- 8	1/2"	13/16" - 16		9,6	37	11	64	24		
M24491-08-10	12	- 8	1/2"	1" - 14		9,6	37	12,5	64,5	30		
M24491-10-10	16	- 10	5/8"	1" - 14		12	41	13	70	30		
M24491-10-12	16	- 10	5/8"	1.3/16" - 12		12,7	41	13,5	73	36		
M24491-12-12	19	- 12	3/4"	1.3/16" - 12		15	58,5	13,5	96	36		
M24491-16-16	25	- 16	1"	1.7/16" - 12		19,8	71,5	13,5	114	41		
M24491-20-20	31	- 20	1.1/4"	1.11/16" - 12		26	82,5	13,6	129	50		

All items are made from brazing with the exception of M24491-04-06, M24491-12-12, M24491-16-16 and M24491-20-20

## SAE STANDARD CONNECTIONS

### M22441/M22443

#### 45° ORFS FEMALE SWEPT ELBOW - SAE J516 / ISO 12151-1

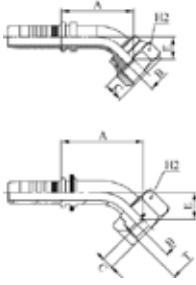

PART. REF.	HOSE BORE			Thread	DIMENSIONS mm							
	DN	Dash	inch		T	B	A	C	E	H2		
M22443-04-04	6	-4	1/4"	9/16" - 18		4	31	8,2	10,5	17		
M22443-04-06	6	-4	1/4"	11/16" - 16		7	31	9,5	10,5	22		
M22443-05-06	8	-5	5/16"	11/16" - 16		7	34	9,5	10,5	22		
M22443-06-06	10	-6	3/8"	11/16" - 16		6	32,5	9,5	11	22		
M22443-06-08	10	-6	3/8"	13/16" - 16		9,3	34	11	12,5	24		
M22441-08-06	12	-8	1/2"	11/16" - 16		7	32,5	9,5	11	22		
M22443-08-08	12	-8	1/2"	13/16" - 16		9	42	11	13	24		
M22443-08-10	12	-8	1/2"	1" - 14		11,5	42	13,5	13,5	30		
M22443-08-12	12	-8	1/2"	1.3/16" - 12		13,9	46,5	14,5	18,5	36		
M22443-10-10	16	-10	5/8"	1" - 14		11,5	49	13,5	16	30		
M22443-10-12	16	-10	5/8"	1.3/16" - 12		13,9	51,5	14,5	18,5	36		
M22441-12-10	19	-12	3/4"	1" - 14		11,5	51	12,5	16,5	30		
M22443-12-12	19	-12	3/4"	1.3/16" - 12		13,9	60,5	14,5	21,5	36		
M22443-12-16	19	-12	3/4"	1.7/16" - 12		19,8	60	14,8	21	41		
M22441-16-12	25	-16	1"	1.3/16" - 12		13,9	66	13,5	21,5	36		
M22443-16-16	25	-16	1"	1.7/16" - 12		19,8	72	14,8	23,5	41		
M22443-16-20	25	-16	1"	1.11/16" - 12		26	74	14,8	25	50		
M22443-20-20	31	-20	1.1/4"	1.11/16" - 12		26	82	14,8	27	50		
M22443-24-24	38	-24	1.1/2"	2" - 12		32	98	14,8	31,5	60		

M22441: CRIMPED BACK-NUT / M22443: SLIP-ON NUT

## SAE STANDARD CONNECTIONS

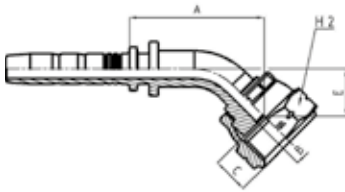

### M22441KR

45° ORFS FEMALE SWEEP ELBOW - SAE J516 / ISO 12151-1

PART. REF.	HOSE BORE			Thread		DIMENSIONS mm						
	DN	Dash	inch			T	B	A	C	E	H2	
M22441-04-04KR	6	- 4	1/4"	9/16" - 18		4,2	30	8	10,5	17		
M22441-06-06KR	10	- 6	3/8"	11/16" - 16		6	31,5	9,5	11	22		
M22441-08-08KR	12	- 8	1/2"	13/16" - 16		9	42,5	11	13,5	24		

## SAE STANDARD CONNECTIONS

### M13010

SAE MALE O-RING BOSS TYPE - SAE J516 / ISO 11926

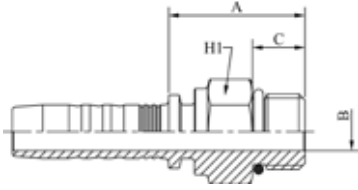

PART. REF.	HOSE BORE			Thread		DIMENSIONS mm						
	DN	Dash	inch			T	B	A	C			
M13010-04-04	6	-4	1/4"	7/16" - 20		4,4	24	9,1	14			
M13010-04-06	6	-4	1/4"	9/16" - 18		7,5	24,5	9,9	17			
M13010-06-06	10	-6	3/8"	9/16" - 18		7,5	25,5	9,9	17			
M13010-06-08	10	-6	3/8"	3/4" - 16		9,9	28,5	11,1	22			
M13010-06-10	10	-6	3/8"	7/8" - 14		12,3	31,5	12,7	25			
M13010-08-08	12	-8	1/2"	3/4" - 16		9,9	29	11,1	22			
M13010-08-10	12	-8	1/2"	7/8" - 14		12,3	32	12,7	25			
M13010-08-12	12	-8	1/2"	1.1/16" - 12		15,5	38,5	15,1	32			
M13010-10-10	16	-10	5/8"	7/8" - 14		12,5	32	12,7	25			
M13010-10-12	16	-10	5/8"	1.1/16" - 12		15,5	37,5	15,1	32			
M13010-12-12	19	-12	3/4"	1.1/16" - 12		15,5	39,5	15,1	32			
M13010-12-16	19	-12	3/4"	1.5/16" - 12		21,5	40	15,1	38			
M13010-16-16	25	-16	1"	1.5/16" - 12		21,5	41	15,1	38			
M13010-20-20	31	-20	1.1/4"	1.5/8" - 12		27,5	43,5	15,1	46			

## SAE STANDARD CONNECTIONS

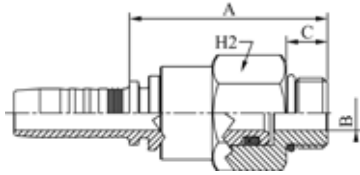

### M14310

SAE SWIVEL MALE O-RING BOSS TYPE - SAE J516 / ISO 11926

PART. REF.	HOSE BORE			Thread	DIMENSIONS mm							
	DN	Dash	inch		T	B	A	C	H2			
M14310-04-04	6	-4	1/4"	7/16" - 20		4	43	9,1	17			
M14310-04-06	6	-4	1/4"	9/16" - 18		7	44	9,9	22			
M14310-06-06	10	-6	3/8"	9/16" - 18		7	48	9,9	22			
M14310-06-08	10	-6	3/8"	3/4" - 16		9,3	47	11,1	22			
M14310-08-08	12	-8	1/2"	3/4" - 16		9,3	53	11,1	27			
M14310-08-10	12	-8	1/2"	7/8" - 14		9,3	41,5	13	27			
M14310-08-12	12	-8	1/2"	1.1/16" - 12		12,5	49,5	15	32			
M14310-10-10	16	-10	5/8"	7/8" - 14		9,3	41,5	13	27			
M14310-12-12	19	-12	3/4"	1.1/16" - 12		12,5	50,5	15	32			

Not to be used as a live swivel

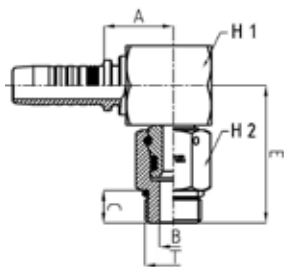

## SAE STANDARD CONNECTIONS

### M14390

90° SAE SWIVEL MALE O-RING BOSS TYPE - SAE J516 / ISO 11926

PART. REF.	HOSE BORE			Thread	DIMENSIONS mm						
	DN	Dash	inch		T	B	A	C	E	H1	H2
M14390-06-06	10	-6	3/8"	9/16" - 18		5,7	20	9,9	40	22	17
M14390-06-08	10	-6	3/8"	3/4" - 16		9,3	20	11,1	44,5	22	22
M14390-08-08	12	-8	1/2"	3/4" - 16		9,3	23,5	11,1	47	27	22
M14390-08-10	12	-8	1/2"	7/8" - 14		9,8	23,5	13	47	27	27
M14390-10-10	16	-10	5/8"	7/8" - 14		9,8	23,5	13	47	27	27
M14390-12-12	19	-12	3/4"	1.1/16" - 12		13	28	15	58,5	34	32

Brazed solution - Not to be used as a live swivel

## SAE STANDARD CONNECTIONS

### M22612

SAE FEMALE 45° CONE SEAT - SAE J516/J512 (THRUST-WIRE NUT)

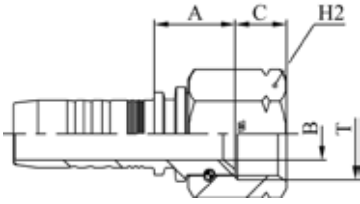

PART. REF.	HOSE BORE			Thread		DIMENSIONS mm					
	DN	Dash	inch			T	B	A	C	H2	
M22612-04-04	6	-4	1/4"	7/16" - 20		4	15,5	8,7	17		
M22612-05-06	8	-5	5/16"	5/8" - 18		7	16	10,8	22		
M22612-06-06	10	-6	3/8"	5/8" - 18		7	16,5	10,8	22		
M22612-12-12	19	-12	3/4"	1.1/16" - 14		15	22,5	14,4	32		

## SAE STANDARD CONNECTIONS

### M22692

90° SAE FEMALE SWEPT ELBOW 45° CONE SEAT - SAE J516/J512 (THRUST-WIRE NUT)

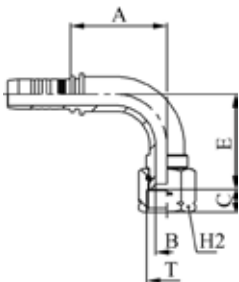

PART. REF.	HOSE BORE			Thread		DIMENSIONS mm					
	DN	Dash	inch			T	B	A	C	E	H2
M22692-04-04	6	-4	1/4"	7/16" - 20		4	28,5	8,7	27	17	
M22692-06-06	10	-6	3/8"	5/8" - 18		7	35,5	10,8	33	22	
M22692-12-12	19	-12	3/4"	1.1/16" - 14		15	62	14,4	58	32	

## SAE STANDARD CONNECTIONS

### M12810

NPTF MALE 60° CONE SEAT - SAE J516/J514

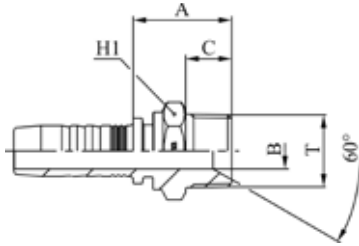

PART. REF.	HOSE BORE			Thread		DIMENSIONS mm						
	DN	Dash	inch			T	B	A	C			
M12810-03-02	5	-3	3/16"	1/8" - 27		3	23,5	10	12			
M12810-03-04	5	-3	3/16"	1/4" - 18		5,5	29	14,5	14			
M12810-04-02	6	-4	1/4"	1/8" - 27		4	24	10	12			
M12810-04-04	6	-4	1/4"	1/4" - 18		5,5	29	14,5	14			
M12810-04-06	6	-4	1/4"	3/8" - 18		9,3	27,5	14,5	19			
M12810-04-08	6	-4	1/4"	1/2" - 14		9,3	33,5	19,2	24			
M12810-05-04	8	-5	5/16"	1/4" - 18		5,5	29,5	14,5	14			
M12810-05-06	8	-5	5/16"	3/8" - 18		9,3	32	14,5	19			
M12810-06-04	10	-6	3/8"	1/4" - 18		5,5	30	14,5	14			
M12810-06-06	10	-6	3/8"	3/8" - 18		9,3	28,5	14,5	19			
M12810-06-08	10	-6	3/8"	1/2" - 14		12,5	34,5	19,2	24			
M12810-08-06	12	-8	1/2"	3/8" - 18		9,3	29	14,5	19			
M12810-08-08	12	-8	1/2"	1/2" - 14		12,5	35	19,2	24			
M12810-08-12	12	-8	1/2"	3/4" - 14		15,5	35,5	19,2	27			
M12810-10-08	16	-10	5/8"	1/2" - 14		12,5	38,5	19,2	24			
M12810-10-12	16	-10	5/8"	3/4" - 14		16	40	19,2	27			
M12810-12-08	19	-12	3/4"	1/2" - 14		12,5	36,5	19,2	27			
M12810-12-12	19	-12	3/4"	3/4" - 14		16	36,5	19,2	27			
M12810-12-16	19	-12	3/4"	1" - 11,5		19,8	46	24,2	36			
M12810-16-12	25	-16	1"	3/4" - 14		15,5	39	19,2	32			
M12810-16-16	25	-16	1"	1" - 11,5		19,8	44	24,2	36			
M12810-16-20	25	-16	1"	1.1/4" - 11,5		26	56,5	25	46			
M12810-20-20	31	-20	1.1/4"	1.1/4" - 11,5		26	56,5	25	46			
M12810-24-24	38	-24	1.1/2"	1.1/2" - 11,5		32	57,5	26	50			
M12810-32-32	51	-32	2"	2" - 11,5		45	64,5	26,5	65			
M12810-40-40	63	-40	2.1/2"	2.1/2" - 8		55,4	78	39,9	80			
M12810-48-48	76	-48	3"	3" - 8		68,9	86	41,5	100			

## SAE STANDARD CONNECTIONS

### M14110R

NPTF SWIVEL MALE 60° CONE SEAT - SAE J516/J514

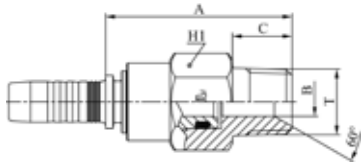

PART. REF.	HOSE BORE			Thread		DIMENSIONS mm						
	DN	Dash	inch			T	B	A	C			
M14110-04-02R	6	-4	1/4"	1/8" - 27		3	42	10	17			
M14110-04-04R	6	-4	1/4"	1/4" - 18		4	46,5	14,5	17			
M14110-04-06R	6	-4	1/4"	3/8" - 18		7	46,5	14,5	19			
M14110-06-04R	10	-6	3/8"	1/4" - 18		4	50,5	14,5	22			
M14110-06-06R	10	-6	3/8"	3/8" - 18		7	50,5	14,5	22			
M14110-06-08R	10	-6	3/8"	1/2" - 14		9,3	55	19,2	24			
M14110-08-06R	12	-8	1/2"	3/8" - 18		7	54,5	14,5	27			
M14110-08-08R	12	-8	1/2"	1/2" - 14		9,3	59	19,2	27			
M14110-12-12R	19	-12	3/4"	3/4" - 14		16	58	19,2	32			
M14110-16-16R	25	-16	1"	1" - 11,5		19,8	66	24,2	38			

Not to be used as a live swivel

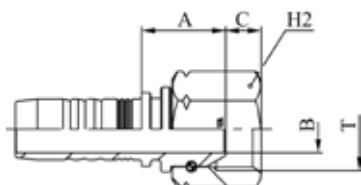

## SAE STANDARD CONNECTIONS

### M22812

NPSM FEMALE 60° CONE - SAE J516/J514 (THRUST-WIRE NUT)

PART. REF.	HOSE BORE			Thread		DIMENSIONS mm						
	DN	Dash	inch			T	B	A	C			
M22812-04-04	6	-4	1/4"	1/4" - 18		4	17,5	4,2	19			
M22812-06-04	10	-6	3/8"	1/4" - 18		4,1	18	4,2	19			
M22812-06-06	10	-6	3/8"	3/8" - 18		7	21	6	22			
M22812-08-08	12	-8	1/2"	1/2" - 14		9,3	23	6,5	27			
M22812-12-12	19	-12	3/4"	3/4" - 14		15	24,5	9	32			
M22812-16-16	25	-16	1"	1" - 11,5		19,8	27,5	10,5	38			



## SAE STANDARD CONNECTIONS

### M23311

ISO/SAE CODE 61 FLANGE - SAE J516 / ISO 12151-3

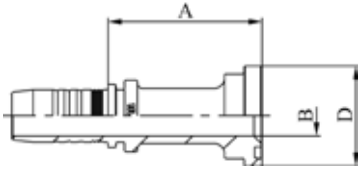

PART. REF.	HOSE BORE			Flange	DIMENSIONS mm						
	DN	Dash	inch		Inch	B	A	D			
M23311-08-08	12	- 8	1/2"	1/2"		9,3	51	30,3			
M23311-08-12	12	- 8	1/2"	3/4"		15,1	58	38			
M23311-10-08	16	- 10	5/8"	1/2"		9,3	51	30,3			
M23311-10-12	16	- 10	5/8"	3/4"		15	65,5	38			
M23311-10-24	16	- 10	5/8"	1.1/2"		32	69,5	60,5			
M23311-12-12	19	- 12	3/4"	3/4"		15	58	38			
M23311-12-16	19	- 12	3/4"	1"		20	58	44,6			
M23311-12-20	19	- 12	3/4"	1.1/4"		26	69,5	51			
M23311-16-12	25	- 16	1"	3/4"		15	60,5	38			
M23311-16-16	25	- 16	1"	1"		19,8	64,5	44,6			
M23311-16-20	25	- 16	1"	1.1/4"		26	70,5	51			
M23311-20-12	31	- 20	1.1/4"	3/4"		15	61	38			
M23311-20-16	31	- 20	1.1/4"	1"		19,8	64,5	44,6			
M23311-20-20	31	- 20	1.1/4"	1.1/4"		26	70,5	51			
M23311-20-24	31	- 20	1.1/4"	1.1/2"		32	72,5	60,5			
M23311-20-32	31	- 20	1.1/4"	2"		42	75,5	71,6			
M23311-24-24	38	- 24	1.1/2"	1.1/2"		32	75,5	60,5			
M23311-24-32	38	- 24	1.1/2"	2"		42	75,5	71,6			
M23311-32-32	51	- 32	2"	2"		42	79	71,6			
M23311-32-40	51	- 32	2"	2.1/2"		56	81	84,3			
M23311-38-40	60	- 38	2.3/8"	2.1/2"		50,5	84	84,3			
M23311-40-32	63	- 40	2.1/2"	2"		42	78,5	71,6			
M23311-40-40	63	- 40	2.1/2"	2.1/2"		55,4	84	84,3			
M23311-40-48	63	- 40	2.1/2"	3"		68,9	79	101,6			
M23311-40-56	63	- 40	2.1/2"	3.1/2"		79	90,5	114,3			
M23311-40-64	63	- 40	2.1/2"	4"		90	96,5	127			
M23311-48-48	76	- 48	3"	3"		68,9	85,5	101,6			
M23311-56-56	89	- 56	3.1/2"	3.1/2"		79	94,5	114,3			
M23311-64-64	102	- 64	4"	4"		90	100,5	127			

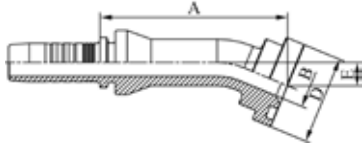

## SAE STANDARD CONNECTIONS

### M23321

22,5° ISO/SAE CODE 61 FLANGE - SAE J516 / ISO 12151-3

PART. REF.	HOSE BORE			Flange		DIMENSIONS mm						
	DN	Dash	inch	Inch		B	A	D	E			
M23321-08-08	12	- 8	1/2"	1/2"		9,3	64	30,3	8			
M23321-12-12	19	- 12	3/4"	3/4"		15	74,5	38	10			
M23321-12-16	19	- 12	3/4"	1"		20	74,5	44,6	10			
M23321-16-16	25	- 16	1"	1"		19,8	89	44,6	11,5			
M23321-16-20	25	- 16	1"	1.1/4"		26	88,5	51	11,5			
M23321-16-24	25	- 16	1"	1.1/2"		32	88,5	60,5	12			
M23321-20-20	31	- 20	1.1/4"	1.1/4"		26	100	51	12			
M23321-20-20018	31	- 20	1.1/4"	1.1/4"		26	99	51	18			
M23321-20-24	31	- 20	1.1/4"	1.1/2"		32	102	60,5	13			
M23321-24-24	38	- 24	1.1/2"	1.1/2"		32	116,5	60,5	14			
M23321-24-24023	38	- 24	1.1/2"	1.1/2"		32	115	60,5	23			
M23321-24-32	38	- 24	1.1/2"	2"		42	116,5	71,6	14			
M23321-32-32	51	- 32	2"	2"		42	134,5	71,6	15			
M23321-40-40	63	- 40	2.1/2"	2.1/2"		52	80	84,3	16,5			
M23321-40-48	63	- 40	2.1/2"	3"		61	107,5	101,6	20,5			
M23321-48-48	76	- 48	3"	3"		61	111	101,6	20,5			

All items are made from solid with the exception of M23321-40-40, M23321-40-48, M23321-48-48

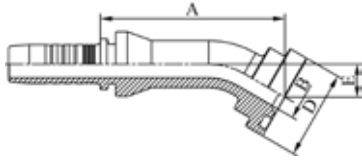

## SAE STANDARD CONNECTIONS

### M23331

30° ISO/SAE CODE 61 FLANGE - SAE J516 / ISO 12151-3

PART. REF.	HOSE BORE			Flange		DIMENSIONS mm						
	DN	Dash	inch	Inch		B	A	D	E			
M23331-08-08	12	- 8	1/2"	1/2"		9,3	62,5	30,3	11			
M23331-08-12	12	- 8	1/2"	3/4"		15	63,5	38	11,5			
M23331-12-12	19	- 12	3/4"	3/4"		15	73	38	14			
M23331-12-16	19	- 12	3/4"	1"		20	73	44,6	14			
M23331-16-16	25	- 16	1"	1"		19,8	87	44,6	16,5			
M23331-16-20	25	- 16	1"	1.1/4"		26	87	51	16,5			
M23331-20-20	31	- 20	1.1/4"	1.1/4"		26	98	51	17,5			
M23331-20-24	31	- 20	1.1/4"	1.1/2"		32	100	60,5	18,5			
M23331-20-24044	31	- 20	1.1/4"	1.1/2"		32	131,5	60,5	44			
M23331-24-24	38	- 24	1.1/2"	1.1/2"		32	114,5	60,5	20			
M23331-24-32	38	- 24	1.1/2"	2"		42	114,5	71,6	20			
M23331-32-32	51	- 32	2"	2"		42	132	71,6	22			
M23331-40-40	63	- 40	2.1/2"	2.1/2"		52	87,5	84,3	24			
M23331-40-48	63	- 40	2.1/2"	3"		52	85	101,6	24,5			
M23331-48-48	76	- 48	3"	3"		61	117,5	101,6	31,5			

All items are made from solid with the exception of M23331-40-40, M23331-40-48, M23331-48-48

## SAE STANDARD CONNECTIONS

### M23341

#### 45° ISO/SAE CODE 61 FLANGE - SAE J516 / ISO 12151-3

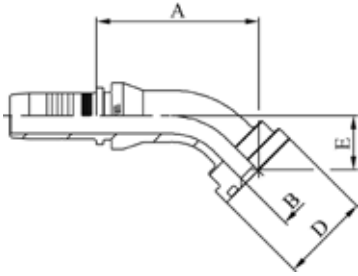

PART. REF.	HOSE BORE			Flange		DIMENSIONS mm						
	DN	Dash	inch	Inch		B	A	D	E			
M23341-06-08	10	- 6	3/8"	1/2"		9,3	52,5	30	17,5			
M23341-08-08	12	- 8	1/2"	1/2"		9,3	58,5	30,3	18,5			
M23341-08-12	12	- 8	1/2"	3/4"		15	59,5	38	19			
M23341-08-16	12	- 8	1/2"	1"		19,8	59,5	44,6	19			
M23341-10-12	16	- 10	5/8"	3/4"		15	61	38	22			
M23341-12-12	19	- 12	3/4"	3/4"		15	71	38	26			
M23341-12-16	19	- 12	3/4"	1"		20	68,5	44,6	23			
M23341-16-12	25	- 16	1"	3/4"		15	74,5	38	23			
M23341-16-16	25	- 16	1"	1"		19,8	81,5	44,6	27,5			
M23341-16-16032	25	- 16	1"	1"		19,8	86	44,5	32			
M23341-16-20	25	- 16	1"	1.1/4"		26	81,5	51	27,5			
M23341-20-16	31	- 20	1.1/4"	1"		19,8	84,5	44,6	29,5			
M23341-20-20	31	- 20	1.1/4"	1.1/4"		26	92	51	29,5			
M23341-20-20038	31	- 20	1.1/4"	1.1/4"		26	100,5	50,9	38			
M23341-20-24	31	- 20	1.1/4"	1.1/2"		32	93,5	60,5	31			
M23341-24-24	38	- 24	1.1/2"	1.1/2"		32	107,5	60,5	34,5			
M23341-24-24044	38	- 24	1.1/2"	1.1/2"		32	117	60,5	44			
M23341-24-32	38	- 24	1.1/2"	2"		42	107,5	71,6	34,5			
M23341-32-20	51	- 32	2"	1.1/4"		26	128,5	51	32			
M23341-32-32	51	- 32	2"	2"		42	124	71,6	39			
M23341-32-32056	51	- 32	2"	2"		42	141	71,5	56			
M23341-32-40	51	- 32	2"	2.1/2"		56	136,5	84,3	49,5			
M23341-40-32	63	- 40	2.1/2"	2"		42	152	71,6	48,5			
M23341-40-40	63	- 40	2.1/2"	2.1/2"		52	95	84,3	48,5			
M23341-40-48	63	- 40	2.1/2"	3"		61	117,5	101,6	53,5			
M23341-48-48	76	- 48	3"	3"		58	125,5	101,6	53,5			
M23341-56-56	89	- 56	3.1/2"	3.1/2"		79	139	114,3	68			
M23341-56-64	89	- 56	3.1/2"	4"		79	124,5	127	53,5			
M23341-64-64	102	- 64	4"	4"		90	132	127	56,5			

All items are made from solid with the exception of M23341-40-40, M23341-40-48, M23341-48-48, M23341-56-56, M23341-56-64, M23341-64-64.

## SAE STANDARD CONNECTIONS

### M23361

60° ISO/SAE CODE 61 FLANGE - SAE J516 / ISO 12151-3

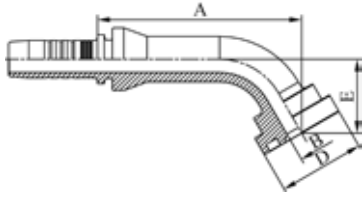

PART. REF.	HOSE BORE			Flange	DIMENSIONS mm								
	DN	Dash	inch		Inch	B	A	D	E				
M23361-08-08	12	- 8	1/2"	1/2"		9,3	71,5	30,3	26				
M23361-08-12	12	- 8	1/2"	3/4"		15	72	38	26,5				
M23361-12-12	19	- 12	3/4"	3/4"		15	87	38	33				
M23361-12-16	19	- 12	3/4"	1"		20	87	44,6	33				
M23361-16-16	25	- 16	1"	1"		19,8	104	44,6	39				
M23361-16-20	25	- 16	1"	1.1/4"		26	104	51	39				
M23361-20-20	31	- 20	1.1/4"	1.1/4"		26	120	51	43				
M23361-20-20065	31	- 20	1.1/4"	1.1/4"		26	107,5	51	65				
M23361-20-24	31	- 20	1.1/4"	1.1/2"		32	121	60,5	44,5				
M23361-24-20	38	- 24	1.1/2"	1.1/4"		26	136,5	51	46,5				
M23361-24-24	38	- 24	1.1/2"	1.1/2"		32	143,5	60,5	50,5				
M23361-24-32	38	- 24	1.1/2"	2"		42	143,5	71,6	51				
M23361-32-32	51	- 32	2"	2"		42	129	71,6	58				
M23361-40-40	63	- 40	2.1/2"	2.1/2"		52	94,5	84,3	67				
M23361-40-48	63	- 40	2.1/2"	3"		52	87,5	101,6	54,5				
M23361-48-48	76	- 48	3"	3"		61	128,5	101,6	79				

All items are made from solid with the exception of M23361-40-40, M23361-40-48, M23361-48-48.

## SAE STANDARD CONNECTIONS

### M23371

67,5° ISO/SAE CODE 61 FLANGE - SAE J516 / ISO 12151-3

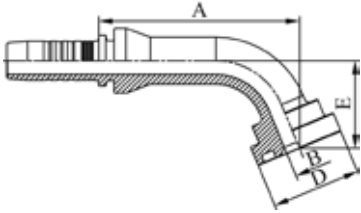

PART. REF.	HOSE BORE			Flange		DIMENSIONS mm						
	DN	Dash	inch	Inch		B	A	D	E			
M23371-08-08	12	- 8	1/2"	1/2"		9,3	68	30,3	29,5			
M23371-08-12	12	- 8	1/2"	3/4"		15	68,5	38	30,5			
M23371-08-16	12	- 8	1/2"	1"		19,8	68,5	44,6	30,5			
M23371-12-12	19	- 12	3/4"	3/4"		15	82	38	38			
M23371-12-16	19	- 12	3/4"	1"		20	82	44,6	38			
M23371-12-20	19	- 12	3/4"	1.1/4"		26	82	51	38			
M23371-16-16	25	- 16	1"	1"		19,8	98,5	44,6	45			
M23371-16-20	25	- 16	1"	1.1/4"		26	98,5	51	45			
M23371-20-20	31	- 20	1.1/4"	1.1/4"		26	114	51	50			
M23371-20-24	31	- 20	1.1/4"	1.1/2"		32	115	60,5	52			
M23371-24-24	38	- 24	1.1/2"	1.1/2"		32	136,5	60,5	59			
M23371-24-32	38	- 24	1.1/2"	2"		42	136,5	71,6	59			
M23371-32-32	51	- 32	2"	2"		42	162	71,6	68,5			
M23371-32-32085	51	- 32	2"	2"		42	150,5	71,6	85			
M23371-32-40	51	- 32	2"	2.1/2"		56	171,5	84,3	83,5			
M23371-40-40	63	- 40	2.1/2"	2.1/2"		52	95	84,3	78			
M23371-40-48	63	- 40	2.1/2"	3"		52	90,5	101,6	64,5			

All items are made from solid with the exception of M23371-40-40, M23371-40-48.

## M23391

90° ISO/SAE CODE 61 FLANGE - SAE J516 / ISO 12151-3

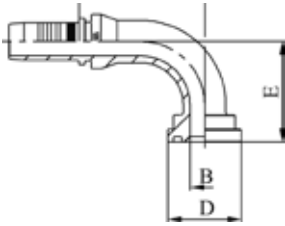

PART. REF.	HOSE BORE			Flange	DIMENSIONS mm							
	DN	Dash	inch		Inch	B	A	D	E			
M23391-06-08	10	- 6	3/8"	1/2"		9,3	44,5	30	34,5			
M23391-08-08	12	- 8	1/2"	1/2"		9,3	54,5	30,3	40			
M23391-08-12	12	- 8	1/2"	3/4"		15	54,5	38	41			
M23391-08-16	12	- 8	1/2"	1"		19,8	54,5	44,6	66			
M23391-10-08	16	- 10	5/8"	1/2"		9,3	56	30,3	46,5			
M23391-10-12	16	- 10	5/8"	3/4"		15	56	38	47,5			
M23391-12-12	19	- 12	3/4"	3/4"		15	64,5	38	52			
M23391-12-16	19	- 12	3/4"	1"		20	64,5	44,6	52			
M23391-12-20	19	- 12	3/4"	1.1/4"		26	64,5	51	52			
M23391-16-12	25	- 16	1"	3/4"		15	71	38	52			
M23391-16-16	25	- 16	1"	1"		19,8	77,5	44,6	62			
M23391-16-20	25	- 16	1"	1.1/4"		26	77,5	51	62			
M23391-16-24	25	- 16	1"	1.1/2"		32	77	60,5	64			
M23391-20-16	31	- 20	1.1/4"	1"		19,8	80	44,6	66			
M23391-20-20	31	- 20	1.1/4"	1.1/4"		26	90,5	51	70			
M23391-20-24	31	- 20	1.1/4"	1.1/2"		32	90,5	60,5	72			
M23391-20-32	31	- 20	1.1/4"	2"		42	93,5	71,6	76			
M23391-24-20	38	- 24	1.1/2"	1.1/4"		26	104,5	51	75			
M23391-24-24	38	- 24	1.1/2"	1.1/2"		32	108	60,5	84			
M23391-24-32	38	- 24	1.1/2"	2"		42	108	71,6	84			
M23391-32-24	51	- 32	2"	1.1/2"		32	133	60,5	84			
M23391-32-32	51	- 32	2"	2"		42	129	71,6	99			
M23391-32-40	51	- 32	2"	2.1/2"		56	132,5	84,3	116			
M23391-40-32	63	- 40	2.1/2"	2"		42	149,5	71,6	114			
M23391-40-40	63	- 40	2.1/2"	2.1/2"		52	88	84,3	119			
M23391-40-48	63	- 40	2.1/2"	3"		61	120	101,6	140			
M23391-48-48	76	- 48	3"	3"		58	123	101,6	140			
M23391-48-56	76	- 48	3"	3.1/2"		61	123	114,3	115			
M23391-56-56	89	- 56	3.1/2"	3.1/2"		79	134,5	114,3	160			
M23391-64-64	102	- 64	4"	4"		90	153,5	127	158,5			

All items are made from solid with the exception of M23391-40-40, M23391-40-48, M23391-48-48, M23391-48-56, M23391-56-56, M23391-64-64.

## SAE STANDARD CONNECTIONS

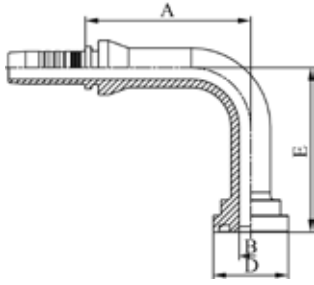

### M23391 LONG DROP

90° LONG DROP ISO/SAE CODE 61 FLANGE - SAE J516 / ISO 12151-3

PART. REF.	HOSE BORE			Flange		DIMENSIONS mm						
	DN	Dash	inch	Inch		B	A	D	E			
M23391-06-08041	10	- 6	3/8"	1/2"		9,3	44,5	30	41			
M23391-12-12058	19	- 12	3/4"	3/4"		15	64,5	38	58			
M23391-16-16070	25	- 16	1"	1"		19,8	77,5	44,5	70			
M23391-16-20117	25	- 16	1"	1.1/4"		26	77,5	51	117			
M23391-16-24107	25	- 16	1"	1.1/2"		32	77	60,5	107			
M23391-20-20091	31	- 20	1.1/4"	1.1/4"		26	90,5	51	91			
M23391-20-20100	31	- 20	1.1/4"	1.1/4"		26	90,5	51	100			
M23391-20-20112	31	- 20	1.1/4"	1.1/4"		26	90,5	51	112			
M23391-20-20130	31	- 20	1.1/4"	1.1/4"		26	90,5	51	130			
M23391-20-20168	31	- 20	1.1/4"	1.1/4"		26	90,5	51	168			
M23391-20-24118	31	- 20	1.1/4"	1.1/2"		32	90,5	60,5	118			
M23391-20-24130	31	- 20	1.1/4"	1.1/2"		32	90,5	60,5	130			
M23391-24-24104	38	- 24	1.1/2"	1.1/2"		32	108	60,5	104			
M23391-24-24148	38	- 24	1.1/2"	1.1/2"		32	108	60,5	148			
M23391-24-24172	38	- 24	1.1/2"	1.1/2"		32	108	60,5	172			
M23391-24-32115	38	- 24	1.1/2"	2"		42	108	71,6	115			
M23391-24-32172	38	- 24	1.1/2"	2"		42	108	71,6	172			
M23391-32-32138	51	- 32	2"	2"		42	129	71,5	138			
M23391-32-32203	51	- 32	2"	2"		42	129	71,6	203			



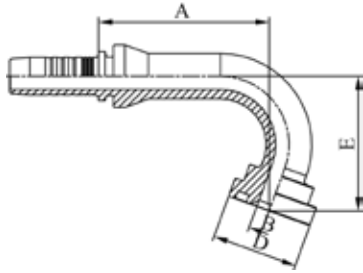

## SAE STANDARD CONNECTIONS

### M23301P

110° ISO/SAE CODE 61 FLANGE - SAE J516 / ISO 12151-3

PART. REF.	HOSE BORE			Flange	DIMENSIONS mm						
	DN	Dash	inch		Inch	B	A	D	E		
M23301-08-12P	12	- 8	1/2"	3/4"	15	53	38	48			
M23301-12-12P	19	- 12	3/4"	3/4"	15	89	38	62			
M23301-12-16P	19	- 12	3/4"	1"	20	89	44,6	62			
M23301-16-16P	25	- 16	1"	1"	19,8	88,5	44,6	79			
M23301-16-20133P	25	- 16	1"	1.1/4"	26	69	51	133			
M23301-20-20P	31	- 20	1.1/4"	1.1/4"	26	102	51	91			
M23301-20-24P	31	- 20	1.1/4"	1.1/2"	32	96,5	60,5	93			
M23301-24-24119P	38	- 24	1.1/2"	1.1/2"	32	105,5	60,5	119			
M23301-32-32P	51	- 32	2"	2"	42	142	71,6	123			

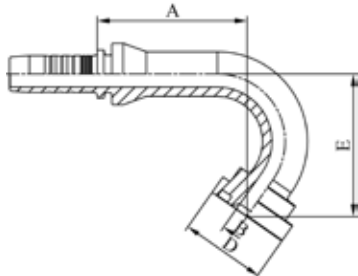

## SAE STANDARD CONNECTIONS

### M23301S

125° ISO/SAE CODE 61 FLANGE - SAE J516 / ISO 12151-3

PART. REF.	HOSE BORE			Flange	DIMENSIONS mm						
	DN	Dash	inch		Inch	B	A	D	E		
M23301-32-32151S	51	- 32	2"	2"	42	118,5	71,6	151			

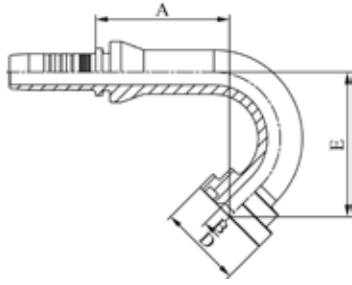

## SAE STANDARD CONNECTIONS

### M23301T

135° ISO/SAE CODE 61 FLANGE - SAE J516 / ISO 12151-3

PART. REF.	HOSE BORE			Flange	DIMENSIONS mm							
	DN	Dash	inch		Inch	B	A	D	E			
M23301-12-12T	19	- 12	3/4"	3/4"		15	74,5	38	70			
M23301-12-16T	19	- 12	3/4"	1"		20	74,5	44,6	70			
M23301-16-16T	25	- 16	1"	1"		19,8	70	44,6	88,5			

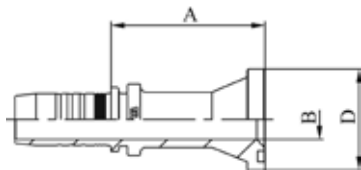

## SAE STANDARD CONNECTIONS

### M23611

ISO/SAE CODE 62 FLANGE - SAE J516 / ISO 12151-3

PART. REF.	HOSE BORE			Flange	DIMENSIONS mm						
	DN	Dash	inch		Inch	B	A	D			
M23611-08-08	12	- 8	1/2"	1/2"		9,3	52	31,8			
M23611-08-12	12	- 8	1/2"	3/4"		15	68,5	41,5			
M23611-10-08	16	- 10	5/8"	1/2"		9,3	52	31,8			
M23611-10-12	16	- 10	5/8"	3/4"		15	70	41,5			
M23611-10-16	16	- 10	5/8"	1"		20	80	47,7			
M23611-12-12	19	- 12	3/4"	3/4"		15	69	41,5			
M23611-12-16	19	- 12	3/4"	1"		20	81	47,7			
M23611-16-16	25	- 16	1"	1"		19,8	82,5	47,7			
M23611-16-20	25	- 16	1"	1.1/4"		26	90	54,2			
M23611-20-16	31	- 20	1.1/4"	1"		19,8	82,5	47,7			
M23611-20-20	31	- 20	1.1/4"	1.1/4"		26	84,5	54,2			
M23611-20-24	31	- 20	1.1/4"	1.1/2"		32	90,5	63,7			
M23611-24-24	38	- 24	1.1/2"	1.1/2"		32	92,5	63,6			
M23611-32-32	51	- 32	2"	2"		42	109	79,5			

## SAE STANDARD CONNECTIONS

### M23691

90° ISO/SAE CODE 62 FLANGE - SAE J516 / ISO 12151-3

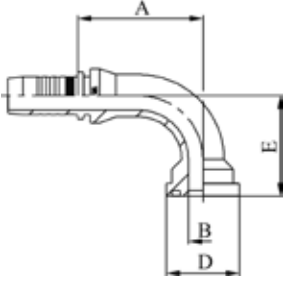

PART. REF.	HOSE BORE			Flange	DIMENSIONS mm						
	DN	Dash	inch		Inch	B	A	D	E		
M23691-08-08	12	- 8	1/2"	1/2"	9,3	54,5	31,8	45			
M23691-08-08040	12	- 8	1/2"	1/2"	9,3	54,5	31,7	41			
M23691-08-12	12	- 8	1/2"	3/4"	15	54,5	41,5	53			
M23691-10-08	16	- 10	5/8"	1/2"	9,3	57,5	31,8	45			
M23691-10-12	16	- 10	5/8"	3/4"	15	53,5	41,5	60,5			
M23691-10-16	16	- 10	5/8"	1"	19,8	56	47,7	64			
M23691-12-12	19	- 12	3/4"	3/4"	15	64	41,5	59			
M23691-12-16	19	- 12	3/4"	1"	20	64,5	47,7	65			
M23691-16-16	25	- 16	1"	1"	19,8	73,5	47,7	68			
M23691-16-20	25	- 16	1"	1.1/4"	26	73,5	54,2	75			
M23691-20-16	31	- 20	1.1/4"	1"	19,8	82,5	47,7	68			
M23691-20-20	31	- 20	1.1/4"	1.1/4"	26	85,5	54,2	81			
M23691-20-20090	31	- 20	1.1/4"	1.1/4"	26	85,5	54,1	90			
M23691-20-24	31	- 20	1.1/4"	1.1/2"	32	85,5	63,7	91,5			
M23691-24-24	38	- 24	1.1/2"	1.1/2"	32	106	63,7	94,5			
M23691-24-24104	38	- 24	1.1/2"	1.1/2"	32	106	63,7	104			
M23691-24-32	38	- 24	1.1/2"	2"	42	106	79,6	110,5			
M23691-32-32	51	- 32	2"	2"	42	138	79,6	132			
M23691-32-32138	51	- 32	2"	2"	42	138	79,6	138			

## SAE STANDARD CONNECTIONS

### M23641

45° ISO/SAE CODE 62 FLANGE - SAE J516 / ISO 12151-3

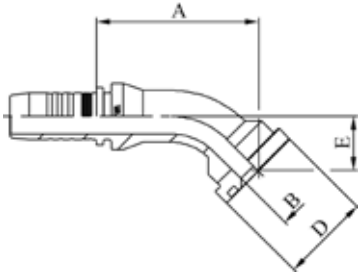

PART. REF.	HOSE BORE			Flange		DIMENSIONS mm						
	DN	Dash	inch	Inch		B	A	D	E			
M23641-08-08	12	- 8	1/2"	1/2"		9,3	59	31,7	19			
M23641-08-12	12	- 8	1/2"	3/4"		15	68	41,5	27,5			
M23641-10-08	16	- 10	5/8"	1/2"		9,3	62,5	31,8	23,5			
M23641-10-12	16	- 10	5/8"	3/4"		15	67,5	41,5	31			
M23641-12-12	19	- 12	3/4"	3/4"		15	72,5	41,5	28			
M23641-12-16	19	- 12	3/4"	1"		20	77	47,7	32,5			
M23641-16-12	25	- 16	1"	3/4"		15	80	41,5	30			
M23641-16-16	25	- 16	1"	1"		19,8	83,5	47,7	32,5			
M23641-16-20	25	- 16	1"	1.1/4"		26	88,5	54,2	37,5			
M23641-20-20	31	- 20	1.1/4"	1.1/4"		26	95	54,2	37,5			
M23641-20-24	31	- 20	1.1/4"	1.1/2"		32	102,5	63,7	45			
M23641-24-24	38	- 24	1.1/2"	1.1/2"		32	118	63,7	44			
M23641-24-32	38	- 24	1.1/2"	2"		42	129	79,6	55,5			
M23641-32-32	51	- 32	2"	2"		42	151,5	79,6	60,5			
M23641-32-32056	51	- 32	2"	2"		42	147,5	79,6	56,5			

## DIN STANDARD CONNECTIONS

### M22010

METRIC STANDPIPE LIGHT DUTY - DIN 2353 / ISO 8434-1

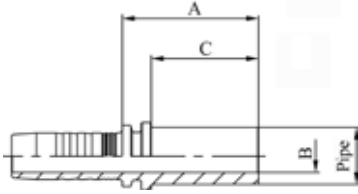

PART. REF.	HOSE BORE			Pipe	DIMENSIONS mm						
	DN	Dash	inch		mm	B	A	C			
M22010-03-04	5	-3	3/16"	4	2	29,5	22				
M22010-03-06	5	-3	3/16"	6	3	29,5	22				
M22010-04-06	6	-4	1/4"	6	3	30	22				
M22010-05-08	8	-5	5/16"	8	5,5	30	22				
M22010-05-10	8	-5	5/16"	10	7	31	23				
M22010-06-10	10	-6	3/8"	10	7	31,5	23				
M22010-06-12	10	-6	3/8"	12	8	31,5	23				
M22010-06-15	10	-6	3/8"	15	10,5	33,5	25				
M22010-08-12	12	-8	1/2"	12	8	32	23				
M22010-08-15	12	-8	1/2"	15	10,5	34	25				
M22010-08-18	12	-8	1/2"	18	12,5	35	26				
M22010-10-18	16	-10	5/8"	18	12,5	35	26				
M22010-10-22	16	-10	5/8"	22	15	37	28				
M22010-12-18	19	-12	3/4"	18	12,5	36,5	26				
M22010-12-22	19	-12	3/4"	22	15	38,5	28				
M22010-16-28	25	-16	1"	28	19,8	41,5	30				
M22010-20-35	31	-20	1.1/4"	35	26	48,5	36				
M22010-24-42	38	-24	1.1/2"	42	32	52,5	40				

## DIN STANDARD CONNECTIONS

### M22110

METRIC STANDPIPE HEAVY DUTY - DIN 2353 / ISO 8434-1

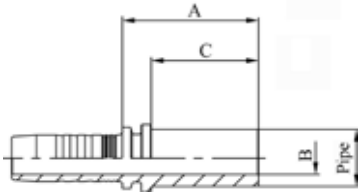

PART. REF.	HOSE BORE			Pipe	DIMENSIONS mm						
	DN	Dash	inch		mm	B	A	C			
M22110-03-08	5	- 3	3/16"	8	3	31	24				
M22110-03-10	5	- 3	3/16"	10	3	29,5	22				
M22110-04-08	6	- 4	1/4"	8	4	32	24				
M22110-04-10	6	- 4	1/4"	10	4	34	26				
M22110-04-12	6	- 4	1/4"	12	7	34	26				
M22110-05-12	8	- 5	5/16"	12	7	34	26				
M22110-06-14	10	- 6	3/8"	14	8	37,5	29				
M22110-08-14	12	- 8	1/2"	14	9,3	38	29				
M22110-08-16	12	- 8	1/2"	16	10,5	39	30				
M22110-10-20	16	- 10	5/8"	20	12,5	45	36				
M22110-12-20	19	- 12	3/4"	20	15	46,5	36				
M22110-12-25	19	- 12	3/4"	25	15	50,5	40				
M22110-16-25	25	- 16	1"	25	15	51,5	40				
M22110-16-30	25	- 16	1"	30	19,8	55,5	44				
M22110-16-38	25	- 16	1"	38	26	61,5	50				
M22110-20-30	31	- 20	1.1/4"	30	20,5	56,5	44				
M22110-20-38	31	- 20	1.1/4"	38	26	62,5	50				
M22110-24-38	38	- 24	1.1/2"	38	26	62,5	50				

## DIN STANDARD CONNECTIONS

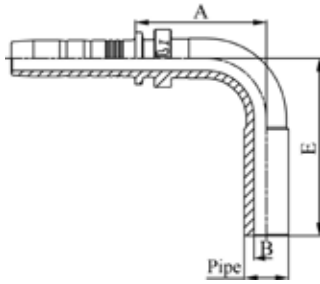

### M22090

90° METRIC STANDPIPE LIGHT DUTY - DIN 2353 / ISO 8434-1

PART. REF.	HOSE BORE			Pipe	DIMENSIONS					
	mm	inch	mm		B	A	E			
M22090-03-06	5	-3	3/16"	6	3	22,5	34			
M22090-04-06	6	-4	1/4"	6	3	23	34			
M22090-05-10	8	-5	5/16"	10	7	29,5	40			
M22090-06-10	10	-6	3/8"	10	7	33	42,5			
M22090-06-12	10	-6	3/8"	12	8	34	45			
M22090-08-12	12	-8	1/2"	12	8	34,5	45			
M22090-08-15	12	-8	1/2"	15	10,5	42	52			
M22090-08-18	12	-8	1/2"	18	12,5	42	55			
M22090-10-18	16	-10	5/8"	18	12,5	49	59			
M22090-10-22	16	-10	5/8"	22	15	53,5	63			
M22090-12-22	19	-12	3/4"	22	15	54,5	63			
M22090-16-28	25	-16	1"	28	19,8	67,5	75			
M22090-20-35	31	-20	1.1/4"	35	26	80,5	94			

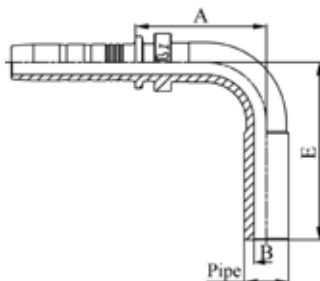

## DIN STANDARD CONNECTIONS

### M22190

90° METRIC STANDPIPE HEAVY DUTY - DIN 2353 / ISO 8434-1

PART. REF.	HOSE BORE			Pipe	DIMENSIONS					
	mm	inch	mm		B	A	E			
M22190-04-08	6	-4	1/4"	8	4	27	38			
M22190-04-10	6	-4	1/4"	10	6	27	41			
M22190-04-12	6	-4	1/4"	12	7	27	44			
M22190-05-12	8	-5	5/16"	12	7	30,5	44			
M22190-06-14	10	-6	3/8"	14	9,3	35	51			
M22190-08-14	12	-8	1/2"	14	9,3	42	53,5			
M22190-08-16	12	-8	1/2"	16	10,5	43	55			
M22190-10-20	16	-10	5/8"	20	12,5	49	66,5			
M22190-12-20	19	-12	3/4"	20	15	54,5	69			
M22190-12-25	19	-12	3/4"	25	15	57,5	75			
M22190-16-25	25	-16	1"	25	15	61,5	76,5			
M22190-16-30	25	-16	1"	30	19,8	69,5	87			

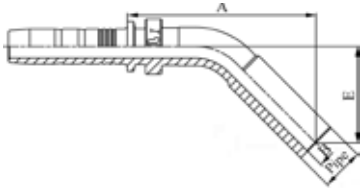

## DIN STANDARD CONNECTIONS

### M22040

45° METRIC STANDPIPE LIGHT DUTY - DIN 2353 / ISO 8434-1

PART. REF.	HOSE BORE			Pipe	DIMENSIONS mm						
	DN	Dash	inch		mm	B	A	E			
M22040-03-06	5	-3	3/16"	6	3	37,5	20,5				
M22040-04-06	6	-4	1/4"	6	3	38	20,5				
M22040-05-10	8	-5	5/16"	10	7	44,5	22,5				
M22040-06-10	10	-6	3/8"	10	7	47,5	23				
M22040-06-12	10	-6	3/8"	12	8	49,5	25				
M22040-08-15	12	-8	1/2"	15	10,5	58	28				
M22040-10-18	16	-10	5/8"	18	12,5	63,5	30,5				
M22040-12-22	19	-12	3/4"	22	15	69	32				
M22040-16-28	25	-16	1"	28	19,8	81,5	37				

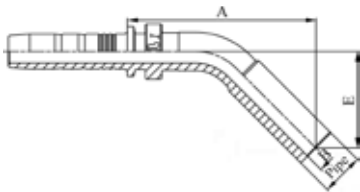

## DIN STANDARD CONNECTIONS

### M22140

45° METRIC STANDPIPE HEAVY DUTY - DIN 2353 / ISO 8434-1

PART. REF.	HOSE BORE			Pipe	DIMENSIONS mm						
	DN	Dash	inch		mm	B	A	E			
M22140-04-08	6	-4	1/4"	8	4	42	22				
M22140-04-10	6	-4	1/4"	10	6	44	24				
M22140-06-14	10	-6	3/8"	14	9,3	54,5	29				
M22140-08-16	12	-8	1/2"	16	10,5	61	30				
M22140-10-20	16	-10	5/8"	20	12,5	69	36				
M22140-12-25	19	-12	3/4"	25	15	80,5	40,5				
M22140-16-25	25	-16	1"	25	15	82	41				



## DIN STANDARD CONNECTIONS

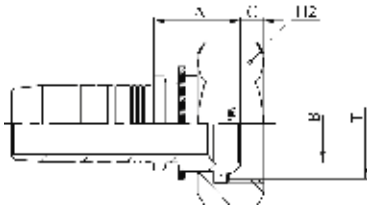

### M21013

METRIC FEMALE 60° CONE - DIN 20078/3863

PART. REF.	HOSE BORE			Thread		DIMENSIONS mm						
	DN	Dash	inch			T	B	A	C	H2		
M21013-10-30	16	- 10	5/8"	M 30x1,5		20	20	6	36			
M21013-12-30	19	- 12	3/4"	M 30x1,5		20	21	6	36			
M21013-16-38	25	- 16	1"	M 38x1,5		26	23	7,5	46			
M21013-20-45	31	- 20	1.1/4"	M 45x1,5		33	23,5	8	50			
M21013-24-52	38	- 24	1.1/2"	M 52x1,5		40	25	8	60			

## DIN STANDARD CONNECTIONS

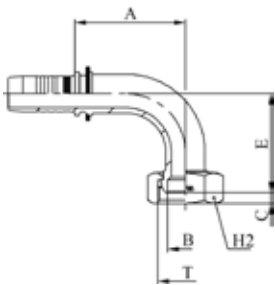

### M21093

90° METRIC FEMALE SWEPT ELBOW 60° CONE - DIN 20078/3863

PART. REF.	HOSE BORE			Thread		DIMENSIONS mm						
	DN	Dash	inch			T	B	A	C	E	H2	
M21093-12-30	19	- 12	3/4"	M 30x1,5		20	61	6	54,5	36		
M21093-16-38	25	- 16	1"	M 38x1,5		26	76,5	7,5	63	46		
M21093-20-45	31	- 20	1.1/4"	M 45x1,5		33	92	8	81	50		

## DIN STANDARD CONNECTIONS

### M21312/M21313

METRIC FEMALE MULTISEAL - DIN 20078/3868

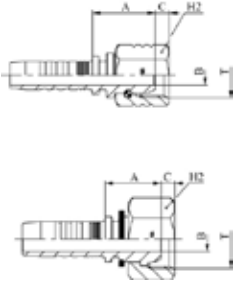

**FITTINGS**  
**F 2-60**

PART. REF.	HOSE BORE			Thread	Pipe	DIMENSIONS mm						
	DN	Dash	inch			T	mm	B	A	C	H2	
M21313-03-12	5	- 3	3/16"	M 12x1,5	6	3	18,5	3,2	14			
M21312-04-12	6	- 4	1/4"	M 12x1,5	6	4	19,5	4	17			
M21313-04-14	6	- 4	1/4"	M 14x1,5	8	4	19,5	3	17			
M21313-04-16	6	- 4	1/4"	M 16x1,5	10	4	19,5	4	19			
M21313-05-16	8	- 5	5/16"	M 16x1,5	10	5,5	19,5	4	19			
M21313-05-18	8	- 5	5/16"	M 18x1,5	12	5,5	19,5	4	22			
M21312-06-14	10	- 6	3/8"	M 14x1,5	8	4	19,5	3,9	17			
M21312-06-16	10	- 6	3/8"	M 16x1,5	10	7	21,5	5	19			
M21313-06-18	10	- 6	3/8"	M 18x1,5	12	7	20	4	22			
M21313-06-22	10	- 6	3/8"	M 22x1,5	15	7	21	4,7	27			
M21312-08-18	12	- 8	1/2"	M 18x1,5	12	7	23	5,9	22			
M21313-08-22	12	- 8	1/2"	M 22x1,5	15	9,3	21,5	4,7	27			
M21312-10-22	16	- 10	5/8"	M 22x1,5	15	9,3	23,5	5,5	27			
M21313-10-26	16	- 10	5/8"	M 26x1,5	18	12,5	22	5	32			

M21312: THRUST-WIRE NUT / M21313: SLIP-ON NUT

## DIN STANDARD CONNECTIONS

### M21392/M21393

#### 90° METRIC FEMALE SWEPT ELBOW MULTISEAL DIN 20078/3868

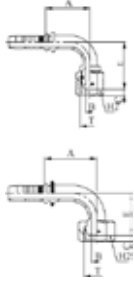

PART. REF.	HOSE BORE			Thread	Pipe	DIMENSIONS mm						
	DN	Dash	inch			T	mm	B	A	C	E	H2
M21393-03-12	5	- 3	3/16"	M 12x1,5	6	3	26	3,2	27	14		
M21392-04-12	6	- 4	1/4"	M 12x1,5	6	4	28	4	30,5	17		
M21393-04-14	6	- 4	1/4"	M 14x1,5	8	4	29,5	3	29,5	17		
M21393-04-16	6	- 4	1/4"	M 16x1,5	10	4	29,5	4	29,5	19		
M21393-05-16	8	- 5	5/16"	M 16x1,5	10	5,5	32	4	29	19		
M21393-05-18	8	- 5	5/16"	M 18x1,5	12	7	32	4	30,5	22		
M21392-06-16	10	- 6	3/8"	M 16x1,5	10	7	35,5	5	38	19		
M21393-06-18	10	- 6	3/8"	M 18x1,5	12	7	36,5	4	31,5	22		
M21393-06-22	10	- 6	3/8"	M 22x1,5	15	7	36,5	4,7	32	27		
M21393-08-22	12	- 8	1/2"	M 22x1,5	15	9,3	45	4,7	36,5	27		
M21393-10-26	16	- 10	5/8"	M 26x1,5	18	12,5	51,5	5	50	32		
M21392-12-26	19	- 12	3/4"	M 26x1,5	18	15	61,5	2,3	63	32		

M21392: THRUST-WIRE NUT / M21393: SLIP-ON NUT

## DIN STANDARD CONNECTIONS

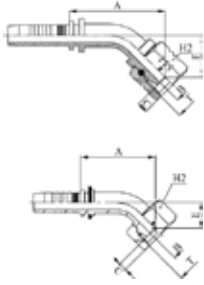

### M21342/M21343

45° METRIC FEMALE SWEPT ELBOW MULTISEAL DIN 20078/3868

PART. REF.	HOSE BORE			Thread	Pipe	DIMENSIONS mm						
	DN	Dash	inch			T	mm	B	A	C	E	H2
M21343-04-14	6	-4	1/4"	M 14x1,5	8	4	36,5	3	15	17		
M21343-04-16	6	-4	1/4"	M 16x1,5	10	4	36,5	4	15	19		
M21342-05-14	8	-5	5/16"	M 14x1,5	8	4	40	3,9	19,5	17		
M21343-05-16	8	-5	5/16"	M 16x1,5	10	5,5	39	4	15	19		
M21342-06-16	10	-6	3/8"	M 16x1,5	10	7	46	5	20	19		
M21343-06-18	10	-6	3/8"	M 18x1,5	12	7	42	4	15,5	22		
M21343-06-22	10	-6	3/8"	M 22x1,5	15	7	42,5	4,7	15,5	27		
M21343-08-22	12	-8	1/2"	M 22x1,5	15	9,3	49,5	4,7	17	27		
M21343-10-26	16	-10	5/8"	M 26x1,5	18	12,5	60	5	24	32		

M21342: THRUST-WIRE NUT / M21343: SLIP-ON NUT

## DIN STANDARD CONNECTIONS

### M11110

METRIC MALE 24° CONE SEAT LIGHT DUTY - DIN 20066 / ISO 12151-2

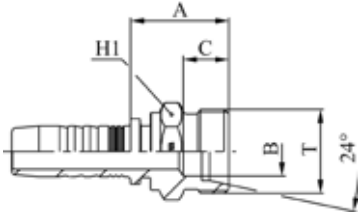

PART. REF.	HOSE BORE			Thread	Pipe	DIMENSIONS mm						
	DN	Dash	inch			T	mm	B	A			
M11110-03-12	5	-3	3/16"	M 12x1,5	6	3	21	10	14			
M11110-04-12	6	-4	1/4"	M 12x1,5	6	4	21,5	10	14			
M11110-04-14	6	-4	1/4"	M 14x1,5	8	4	21,5	10	14			
M11110-04-16	6	-4	1/4"	M 16x1,5	10	7	23,5	11	17			
M11110-04-18	6	-4	1/4"	M 18x1,5	12	9	23,5	11	19			
M11110-05-16	8	-5	5/16"	M 16x1,5	10	7	24	11	17			
M11110-05-18	8	-5	5/16"	M 18x1,5	12	9	24	11	19			
M11110-06-16	10	-6	3/8"	M 16x1,5	10	7	24	11	17			
M11110-06-18	10	-6	3/8"	M 18x1,5	12	9	24,5	11	19			
M11110-06-22	10	-6	3/8"	M 22x1,5	15	10	25,5	12	22			
M11110-06-26	10	-6	3/8"	M 26x1,5	18	12,5	26,5	12	27			
M11110-08-16	12	-8	1/2"	M 16x1,5	10	7	24,5	11	22			
M11110-08-18	12	-8	1/2"	M 18x1,5	12	9,3	24,5	11	22			
M11110-08-22	12	-8	1/2"	M 22x1,5	15	10	25,5	12	22			
M11110-08-26	12	-8	1/2"	M 26x1,5	18	12,5	26,5	12	27			
M11110-10-22	16	-10	5/8"	M 22x1,5	15	10	25,5	12	22			
M11110-10-26	16	-10	5/8"	M 26x1,5	18	12,5	26,5	12	27			
M11110-10-30	16	-10	5/8"	M 30x2	22	15	28,5	14	30			
M11110-12-26	19	-12	3/4"	M 26x1,5	18	15	28	12	27			
M11110-12-30	19	-12	3/4"	M 30x2	22	15	30	14	30			
M11110-12-36	19	-12	3/4"	M 36x2	28	19,8	31	14	36			
M11110-16-36	25	-16	1"	M 36x2	28	19,8	32,5	14	36			
M11110-20-45	31	-20	1.1/4"	M 45x2	35	26	40,5	16	46			
M11110-24-52	38	-24	1.1/2"	M 52x2	42	32	43	16	55			

## DIN STANDARD CONNECTIONS

### M21512/M21513

METRIC O-RING FEMALE 24° CONE LIGHT DUTY - DIN 20066 / ISO 12151-2

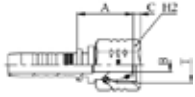

PART. REF.	HOSE BORE			Thread	Pipe	DIMENSIONS mm						
	DN	Dash	inch			T	mm	B	A	C	H2	
M21513-03-12	5	- 3	3/16"	M 12x1,5	6	3	22	0,7	14			
M21513-03-14	5	- 3	3/16"	M 14x1,5	8	4	24,5	1,3	17			
M21512-04-12	6	- 4	1/4"	M 12x1,5	6	3	21	2,2	17			
M21513-04-14	6	- 4	1/4"	M 14x1,5	8	4	22	1,3	17			
M21513-04-16	6	- 4	1/4"	M 16x1,5	10	6	22,5	1,8	19			
M21513-04-18	6	- 4	1/4"	M 18x1,5	12	7	22	2	22			
M21512-05-14	8	- 5	5/16"	M 14x1,5	8	4	20	2,9	17			
M21513-05-16	8	- 5	5/16"	M 16x1,5	10	6	22,5	1,8	19			
M21513-05-18	8	- 5	5/16"	M 18x1,5	12	7	22	2	22			
M21512-06-16	10	- 6	3/8"	M 16x1,5	10	6	23	3	19			
M21513-06-18	10	- 6	3/8"	M 18x1,5	12	7	22,5	2	22			
M21513-06-22	10	- 6	3/8"	M 22x1,5	15	9,3	25	1,5	27			
M21512-08-18	12	- 8	1/2"	M 18x1,5	12	7	29	2,9	22			
M21513-08-22	12	- 8	1/2"	M 22x1,5	15	9,3	25,5	1,5	27			
M21513-08-26	12	- 8	1/2"	M 26x1,5	18	12,5	26	2	32			
M21512-10-18	16	- 10	5/8"	M 18x1,5	12	7	29	2,9	22			
M21512-10-22	16	- 10	5/8"	M 22x1,5	15	9,5	26,5	2,4	27			
M21513-10-26	16	- 10	5/8"	M 26x1,5	18	12,5	26	2	32			
M21513-10-30	16	- 10	5/8"	M 30x2	22	15	34	3	36			
M21513-10-36	16	- 10	5/8"	M 36x2	28	20	30,5	3,7	41			
M21512-12-22	19	- 12	3/4"	M 22x1,5		9,5	31	2,4	27			
M21512-12-26	19	- 12	3/4"	M 26x1,5	18	12,5	31	2,3	32			
M21513-12-30	19	- 12	3/4"	M 30x2	22	15	28	3	36			
M21513-12-36	19	- 12	3/4"	M 36x2	28	20	28,5	3,7	41			
M21512-16-30	25	- 16	1"	M 30x2	22	15	34	4,2	36			
M21513-16-36	25	- 16	1"	M 36x2	28	19,8	29,5	3,7	41			
M21513-16-45	25	- 16	1"	M 45x2	35	26	39	4	50			
M21512-20-36	31	- 20	1.1/4"	M 36x2	28	19,8	35,5	5	41			
M21513-20-45	31	- 20	1.1/4"	M 45x2	35	26	33	4	50			
M21513-20-52	31	- 20	1.1/4"	M 52x2	42	32	32,5	4,5	60			
M21512-24-45	38	- 24	1.1/2"	M 45x2	35	26	42,5	5,8	50			
M21513-24-52	38	- 24	1.1/2"	M 52x2	42	32	33	4,5	60			
M21512-32-52	51	- 32	2"	M 52x2	42	32	50,5	5,6	60			

M21512: THRUST-WIRE NUT / M21513: SLIP-ON NUT

## DIN STANDARD CONNECTIONS

### M21592/M21593

90° METRIC O-RING FEMALE SWEPT ELBOW 24° CONE LIGHT DUTY  
DIN 20066 / ISO 12151-2



PART. REF.	HOSE BORE			Thread	Pipe	DIMENSIONS mm						
	DN	Dash	inch			T	mm	B	A	C	E	H2
M21593-03-12	5	- 3	3/16"	M 12x1,5	6	3	26	0,7	30	14		
M21593-03-14	5	- 3	3/16"	M 14x1,5	8	4	29	1,3	31,5	17		
M21592-04-12	6	- 4	1/4"	M 12x1,5	6	3	28,5	2,2	32,5	17		
M21593-04-14	6	- 4	1/4"	M 14x1,5	8	4	29,5	1,3	31,5	17		
M21593-04-16	6	- 4	1/4"	M 16x1,5	10	6	29,5	1,8	32	19		
M21593-04-18	6	- 4	1/4"	M 18x1,5	12	7	29,5	2	33	22		
M21592-05-14	8	- 5	5/16"	M 14x1,5	8	4	31	2,9	33	17		
M21593-05-16	8	- 5	5/16"	M 16x1,5	10	6	32	1,8	32,5	19		
M21593-05-18	8	- 5	5/16"	M 18x1,5	12	7	32	2	32,5	22		
M21593-05-22	8	- 5	5/16"	M 22x1,5	15	9,3	36	1,5	35	27		
M21592-06-16	10	- 6	3/8"	M 16x1,5	10	6	35,5	3	40	19		
M21593-06-18	10	- 6	3/8"	M 18x1,5	12	7	36,5	2	33,5	22		
M21593-06-22	10	- 6	3/8"	M 22x1,5	15	9,3	36,5	1,5	35	27		
M21592-08-18	12	- 8	1/2"	M 18x1,5	12	7	44	2,9	48	22		
M21593-08-22	12	- 8	1/2"	M 22x1,5	15	9,3	45	1,5	39,5	27		
M21593-08-26	12	- 8	1/2"	M 26x1,5	18	12,5	45	2	40	32		
M21592-10-22	16	- 10	5/8"	M 22x1,5	15	9,3	53,5	3	57,5	27		
M21593-10-26	16	- 10	5/8"	M 26x1,5	18	12,5	51,5	2	53	32		
M21593-10-30	16	- 10	5/8"	M 30x2	22	15	51,5	3	54	36		
M21592-12-26	19	- 12	3/4"	M 26x1,5	18	12,5	61,5	2,3	63	32		
M21593-12-30	19	- 12	3/4"	M 30x2	22	15	61,5	3	59,5	36		
M21593-12-36	19	- 12	3/4"	M 36x2	28	19,8	61,5	3,7	61	41		
M21592-16-30	25	- 16	1"	M 30x2	22	15	79,5	4,2	80,5	36		
M21593-16-36	25	- 16	1"	M 36x2	28	19,8	76,5	3,7	69,5	41		
M21593-16-45	25	- 16	1"	M 45x2	35	26	79	4	72	50		
M21592-20-36	31	- 20	1.1/4"	M 36x2	28	19,8	93,5	5	92	41		
M21593-20-45	31	- 20	1.1/4"	M 45x2	35	26	93,5	4	81	50		
M21592-24-36	38	- 24	1.1/2"	M 36x2	28	19,8	97	5	68	41		
M21593-24-52	38	- 24	1.1/2"	M 52x2	42	32	107,5	4,5	98	60		
M21592-32-52	51	- 32	2"	M 52x2	42	32	131	5,6	119	60		

M21592: THRUST-WIRE NUT / M21593: SLIP-ON NUT

## DIN STANDARD CONNECTIONS

### M21542/M21543

45° METRIC O-RING FEMALE SWEEP ELBOW 24° CONE LIGHT DUTY  
DIN 20066 / ISO 12151-2

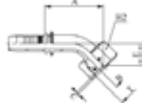
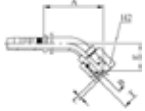

PART. REF.	HOSE BORE			Thread	Pipe	DIMENSIONS mm						
	DN	Dash	inch			T	mm	B	A	C	E	H2
M21543-03-12	5	- 3	3/16"	M 12x1,5	6	3	35	0,7	16	14		
M21542-04-12	6	- 4	1/4"	M 12x1,5	6	3	39	2,2	18	17		
M21543-04-14	6	- 4	1/4"	M 14x1,5	8	4	38	1,3	16,5	17		
M21543-04-16	6	- 4	1/4"	M 16x1,5	10	6	38	1,8	17	19		
M21543-04-18	6	- 4	1/4"	M 18x1,5	12	7	38,5	2	17,5	22		
M21543-05-16	8	- 5	5/16"	M 16x1,5	10	6	41,5	1,8	17,5	19		
M21543-05-18	8	- 5	5/16"	M 18x1,5	12	7	41,5	2	17	22		
M21542-06-16	10	- 6	3/8"	M 16x1,5	10	6	47,5	3	21,5	19		
M21543-06-18	10	- 6	3/8"	M 18x1,5	12	7	43,5	2	16,5	22		
M21543-06-22	10	- 6	3/8"	M 22x1,5	15	9,3	45	1,5	18	27		
M21542-08-18	12	- 8	1/2"	M 18x1,5	12	7	56,5	2,9	25	22		
M21543-08-22	12	- 8	1/2"	M 22x1,5	15	9,3	52	1,5	19	27		
M21543-08-26	12	- 8	1/2"	M 26x1,5	18	12,5	52,5	2	19,5	32		
M21542-10-22	16	- 10	5/8"	M 22x1,5	15	9,3	65,5	3	29	27		
M21543-10-26	16	- 10	5/8"	M 26x1,5	18	12,5	62	2	26,5	32		
M21542-12-26	19	- 12	3/4"	M 26x1,5	18	12,5	73	2,3	31	32		
M21543-12-30	19	- 12	3/4"	M 30x2	22	15	71	3	28,5	36		
M21543-12-36	19	- 12	3/4"	M 36x2	28	19,8	72	3,7	30	41		
M21543-16-36	25	- 16	1"	M 36x2	28	19,8	85	3,7	32	41		
M21542-20-36	31	- 20	1.1/4"	M 36x2	28	19,8	107,5	5	44	41		
M21543-20-45	31	- 20	1.1/4"	M 45x2	35	26	100	4	36	50		
M21543-20-52	31	- 20	1.1/4"	M 52x2	42	32	100	4,5	42	60		
M21542-24-36	38	- 24	1.1/2"	M 36x2	28	19,8	113	5	34,5	41		
M21543-24-52	38	- 24	1.1/2"	M 52x2	42	32	117	4,5	44,5	60		

M21542: THRUST-WIRE NUT / M21543: SLIP-ON NUT



## DIN STANDARD CONNECTIONS

### M11210

METRIC MALE 24° CONE SEAT HEAVY DUTY - DIN 20066 / ISO 12151-2

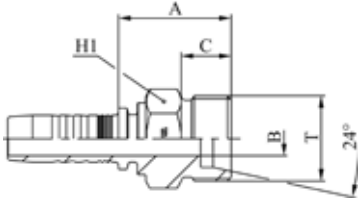

PART. REF.	HOSE BORE			Thread	Pipe	DIMENSIONS mm						
	DN	Dash	inch			T	mm	B	A			
M11210-04-16	6	- 4	1/4"	M 16x1,5	8	5,5	25,5	12	17			
M11210-04-18	6	- 4	1/4"	M 18x1,5	10	6	26,5	12	19			
M11210-04-20	6	- 4	1/4"	M 20x1,5	12	7	29	12	22			
M11210-05-16	8	- 5	5/16"	M 16x1,5	8	5,5	26	12	17			
M11210-05-18	8	- 5	5/16"	M 18x1,5	10	7	26,5	12	19			
M11210-05-20	8	- 5	5/16"	M 20x1,5	12	7	29	12	22			
M11210-06-18	10	- 6	3/8"	M 18x1,5	10	7	27	12	19			
M11210-06-20	10	- 6	3/8"	M 20x1,5	12	7	29	12	22			
M11210-06-22	10	- 6	3/8"	M 22x1,5	14	8	31	14	22			
M11210-08-20	12	- 8	1/2"	M 20x1,5	12	9,3	29,5	12	22			
M11210-08-22	12	- 8	1/2"	M 22x1,5	14	9,3	31,5	14	22			
M11210-08-24	12	- 8	1/2"	M 24x1,5	16	9,3	31,5	14	24			
M11210-10-30	16	- 10	5/8"	M 30x2	20	15	35,5	16	30			
M11210-10-36	16	- 10	5/8"	M 36x2	25	19,8	40	18	36			
M11210-12-30	19	- 12	3/4"	M 30x2	20	15	37	16	30			
M11210-12-36	19	- 12	3/4"	M 36x2	25	19,8	41	18	36			
M11210-16-36	25	- 16	1"	M 36x2	25	19,8	42,5	18	36			
M11210-16-42	25	- 16	1"	M 42x2	30	25	44,5	20	46			
M11210-20-52	31	- 20	1.1/4"	M 52x2	38	30	51	22	55			

## DIN STANDARD CONNECTIONS

### M21612/M21613

METRIC O-RING FEMALE 24° CONE HEAVY DUTY - DIN 20066 / ISO 12151-2

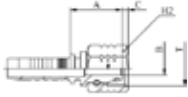

PART. REF.	HOSE BORE			Thread	Pipe	DIMENSIONS mm						
	DN	Dash	inch			T	mm	B	A	C	H2	
M21613-03-14	5	- 3	3/16"	M 14x1,5	6	2,5	25,5	3,5	17			
M21613-03-16	5	- 3	3/16"	M 16x1,5	8	3	21,5	3,4	19			
M21613-04-14	6	- 4	1/4"	M 14x1,5	6	3	23,5	1,9	17			
M21613-04-16	6	- 4	1/4"	M 16x1,5	8	4	22	3,4	19			
M21613-04-18	6	- 4	1/4"	M 18x1,5	10	4	28	2,5	22			
M21613-04-20	6	- 4	1/4"	M 20x1,5	12	7	26	2	24			
M21613-05-18	8	- 5	5/16"	M 18x1,5	10	5,5	28	2,5	22			
M21613-05-20	8	- 5	5/16"	M 20x1,5	12	5,5	25	2	24			
M21613-06-18	10	- 6	3/8"	M 18x1,5	10	7	28,5	2,5	22			
M21613-06-20	10	- 6	3/8"	M 20x1,5	12	7	25,5	2	24			
M21613-06-22	10	- 6	3/8"	M 22x1,5	14	7	32,5	3	27			
M21613-06-24	10	- 6	3/8"	M 24x1,5	16	7	32	4	30			
M21612-08-20	12	- 8	1/2"	M 20x1,5	12	7	29	2,5	24			
M21612-08-22	12	- 8	1/2"	M 22x1,5	14	7	27	2,5	27			
M21613-08-24	12	- 8	1/2"	M 24x1,5	16	9,3	26,5	4	30			
M21613-08-30	12	- 8	1/2"	M 30x2	20	12,5	37	3,5	36			
M21612-10-24	16	- 10	5/8"	M 24x1,5	16	9,3	29,5	4	30			
M21613-10-30	16	- 10	5/8"	M 30x2	20	12,5	30,5	3,5	36			
M21613-10-36	16	- 10	5/8"	M 36x2	25	15	40	4,5	41			
M21612-12-24	19	- 12	3/4"	M 24x1,5	16	9,3	30,5	4	30			
M21612-12-30	19	- 12	3/4"	M 30x2	20	12,5	33,5	2,2	36			
M21613-12-36	19	- 12	3/4"	M 36x2	25	15	34	4,5	41			
M21612-16-30	25	- 16	1"	M 30x2	20	12,5	34,5	2,2	36			
M21612-16-36	25	- 16	1"	M 36x2	25	15	35,5	1,7	41			
M21613-16-42	25	- 16	1"	M 42x2	30	19,8	35,5	6,3	50			
M21613-20-52	31	- 20	1.1/4"	M 52x2	38	26	37,5	8	60			
M21613-24-52	38	- 24	1.1/2"	M 52x2	38	26	49,5	8	60			

M21612: THRUST-WIRE NUT / M21613: SLIP-ON NUT

## DIN STANDARD CONNECTIONS

### M21692/M21693

90° METRIC O-RING FEMALE SWEPT ELBOW 24° CONE HEAVY DUTY  
DIN 20066 / ISO 12151-2

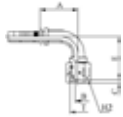

PART. REF.	HOSE BORE			Thread	Pipe	DIMENSIONS mm						
	DN	Dash	inch			T	mm	B	A	C	E	H2
M21693-03-14	5	- 3	3/16"	M 14x1,5	6	3	26	3,5	30	17		
M21693-03-16	5	- 3	3/16"	M 16x1,5	8	3	26	3,4	29,5	19		
M21693-04-14	6	- 4	1/4"	M 14x1,5	6	3	29,5	1,9	32,5	17		
M21693-04-16	6	- 4	1/4"	M 16x1,5	8	4	29,5	3,4	29,5	19		
M21693-04-18	6	- 4	1/4"	M 18x1,5	10	4	29,5	2,5	31	22		
M21693-04-20	6	- 4	1/4"	M 20x1,5	12	5,5	29,5	2	34,5	24		
M21693-05-18	8	- 5	5/16"	M 18x1,5	10	4	32	2,5	33,5	22		
M21693-05-20	8	- 5	5/16"	M 20x1,5	12	5,5	32	2	34	24		
M21692-06-18	10	- 6	3/8"	M 18x1,5	10	4	35,5	3,9	42,5	22		
M21693-06-20	10	- 6	3/8"	M 20x1,5	12	7	36,5	2	35	24		
M21693-06-22	10	- 6	3/8"	M 22x1,5	14	7	36,5	3	37	27		
M21693-06-24	10	- 6	3/8"	M 24x1,5	16	9,3	36,5	4	36	30		
M21692-08-22	12	- 8	1/2"	M 22x1,5	14	7	44	2,5	48,5	27		
M21693-08-24	12	- 8	1/2"	M 24x1,5	16	9,3	45	4	40,5	30		
M21693-08-30	12	- 8	1/2"	M 30x2	20	12,5	45	3,5	44,5	36		
M21692-10-24	16	- 10	5/8"	M 24x1,5	16	9,3	53,5	4	58,5	30		
M21693-10-30	16	- 10	5/8"	M 30x2	20	12,5	51,5	3,5	57,5	36		
M21692-12-30	19	- 12	3/4"	M 30x2	20	12,5	61,5	2,2	67,5	36		
M21693-12-36	19	- 12	3/4"	M 36x2	25	15	61,5	4,5	64,5	41		
M21692-16-36	25	- 16	1"	M 36x2	25	15	79,5	1,7	86	41		
M21693-16-42	25	- 16	1"	M 42x2	30	19,8	79	6,3	74,5	50		
M21693-20-52	31	- 20	1.1/4"	M 52x2	38	26	93,5	8	85,5	60		
M21692-24-52	38	- 24	1.1/2"	M 52x2	38	24,7	91,5	8,8	95,5	60		

M21692: THRUST-WIRE NUT / M21693: SLIP-ON NUT

## DIN STANDARD CONNECTIONS

### M21642/M21643

45° METRIC O-RING FEMALE SWEPT ELBOW 24° CONE HEAVY DUTY  
DIN 20066 / ISO 12151-2

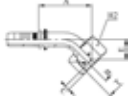
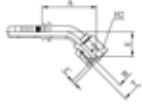

PART. REF.	HOSE BORE			Thread	Pipe	DIMENSIONS mm						
	DN	Dash	inch			T	mm	B	A	C	E	H2
M21643-04-14	6	-4	1/4"	M 14x1,5	6	3	38,5	1,9	17,5	17		
M21643-04-16	6	-4	1/4"	M 16x1,5	8	4	36,5	3,4	15	19		
M21643-04-18	6	-4	1/4"	M 18x1,5	10	4	37,5	2,5	16,5	22		
M21643-05-18	8	-5	5/16"	M 18x1,5	10	4	42,5	2,5	18	22		
M21643-05-20	8	-5	5/16"	M 20x1,5	12	5,5	42	2	18,5	24		
M21642-06-18	10	-6	3/8"	M 18x1,5	10	4	49	3,9	23	22		
M21643-06-20	10	-6	3/8"	M 20x1,5	12	7	45	2,5	18	24		
M21643-06-22	10	-6	3/8"	M 22x1,5	14	7	45,5	3	18,5	27		
M21642-08-22	12	-8	1/2"	M 22x1,5	14	7	57,5	2,5	25,5	27		
M21643-08-24	12	-8	1/2"	M 24x1,5	16	9,3	52,5	4	20	30		
M21643-10-30	16	-10	5/8"	M 30x2	20	12,5	65,5	3,5	29,5	36		
M21642-12-30	19	-12	3/4"	M 30x2	20	12,5	76,5	2,2	34	36		
M21643-12-36	19	-12	3/4"	M 36x2	25	15	75	4,5	32,5	41		
M21642-16-36	25	-16	1"	M 36x2	25	15	98	1,7	43,5	41		
M21643-16-42	25	-16	1"	M 42x2	30	19,8	90	6,3	35,5	50		
M21643-20-52	31	-20	1.1/4"	M 52x2	38	26	103	8	39,5	60		
M21642-24-52	38	-24	1.1/2"	M 52x2	38	24,7	111	8,8	48	60		

M21642: THRUST-WIRE NUT / M21643: SLIP-ON NUT

## NF STANDARD CONNECTIONS

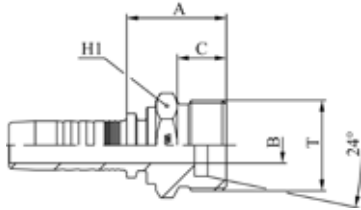

### M11710

#### FRENCH METRIC MALE 24° CONE SEAT MILLIMETRIC TYPE

PART. REF.	HOSE BORE			Thread	Pipe	DIMENSIONS mm						
	DN	Dash	inch			T	mm	B	A	C	H1	
M11710-10-2718	16	- 10	5/8"	M 27x1,5	18	12,5	28,5	14	28			
M11710-10-2720	16	- 10	5/8"	M 27x1,5	20	12,5	28,5	14	28			
M11710-12-30	19	- 12	3/4"	M 30x1,5	22	15	30	14	30			
M11710-12-33	19	- 12	3/4"	M 33x1,5	25	15	31	14	34			

## NF STANDARD CONNECTIONS

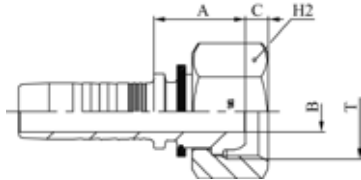

### M21713

#### FRENCH METRIC FEMALE MILLIMETRIC TYPE (SLIP-ON NUT)

PART. REF.	HOSE BORE			Thread	Pipe	DIMENSIONS mm						
	DN	Dash	inch			T	mm	B	A	C	H2	
M21713-10-2718	16	- 10	5/8"	M 27x1,5	18	12,5	21,5	5	32			
M21713-10-2720	16	- 10	5/8"	M 27x1,5	20	12,5	21,5	5	32			
M21713-12-30	19	- 12	3/4"	M 30x1,5	22	15	25,5	2	36			
M21713-12-33	19	- 12	3/4"	M 33x1,5	25	15	25,5	2	38			
M21713-16-36	25	- 16	1"	M 36x1,5	28	19,8	28	4,7	41			
M21713-16-39	25	- 16	1"	M 39x1,5	30	19,8	28,5	4,2	46			

## NF STANDARD CONNECTIONS

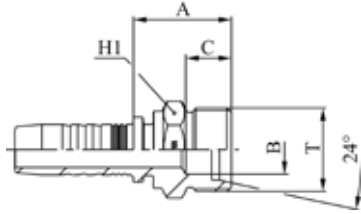

### M11810

#### FRENCH METRIC MALE 24° CONE SEAT GAZ TYPE

PART. REF.	HOSE BORE			Thread	Pipe	DIMENSIONS mm						
	DN	Dash	inch			T	mm	B	A	C	H1	
M11810-05-20	8	- 5	5/16"	M 20x1,5	13,25	8	27	12	22			
M11810-06-20	10	- 6	3/8"	M 20x1,5	13,25	8	27,5	12	22			
M11810-06-24	10	- 6	3/8"	M 24x1,5	16,75	12	28	12	24			
M11810-08-24	12	- 8	1/2"	M 24x1,5	16,75	12	28,5	12	24			
M11810-10-30	16	- 10	5/8"	M 30x1,5	21,25	15	31,5	14	30			
M11810-12-36	19	- 12	3/4"	M 36x1,5	26,75	21	34	14	36			
M11810-16-45	25	- 16	1"	M 45x1,5	33,5	26	39,5	16	46			

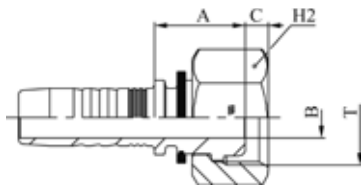

## NF STANDARD CONNECTIONS

### M21813

#### FRENCH METRIC FEMALE GAZ TYPE (SLIP-ON NUT)

PART. REF.	HOSE BORE			Thread	Pipe	DIMENSIONS mm						
	DN	Dash	inch			T	mm	B	A	C	H2	
M21813-04-20	6	- 4	1/4"	M 20x1,5	13,25	7	22	4	24			
M21813-05-20	8	- 5	5/16"	M 20x1,5	13,25	7	22	4	24			
M21813-06-20	10	- 6	3/8"	M 20x1,5	13,25	7	22,5	4	24			
M21813-06-24	10	- 6	3/8"	M 24x1,5	16,75	9,3	25,5	3,5	30			
M21813-08-24	12	- 8	1/2"	M 24x1,5	16,75	9,3	26	3,5	30			
M21813-08-30	12	- 8	1/2"	M 30x1,5	21,25	12,5	23,5	2	36			
M21813-10-30	16	- 10	5/8"	M 30x1,5	21,25	12,5	23,5	2	36			
M21813-12-36	19	- 12	3/4"	M 36x1,5	26,75	15	27	4,7	41			
M21813-16-45	25	- 16	1"	M 45x1,5	33,5	19,8	27	4,5	50			

## NF STANDARD CONNECTIONS

### M21893

90° FRENCH METRIC FEMALE GAZ TYPE (SLIP-ON NUT)

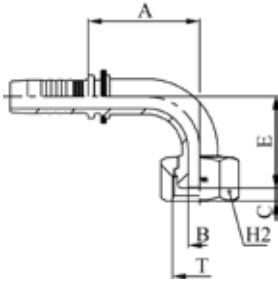

PART. REF.	HOSE BORE			Thread	Pipe	DIMENSIONS mm						
	DN	Dash	inch			T	mm	B	A	C	E	H2
M21893-05-20	8	- 5	5/16"	M 20x1,5	13,25	7	32	4	29,5	24		
M21893-06-20	10	- 6	3/8"	M 20x1,5	13,25	7	36,5	4	33,5	24		
M21893-08-24	12	- 8	1/2"	M 24x1,5	16,75	12	45	3,5	41	30		
M21893-10-30	16	- 10	5/8"	M 30x1,5	21,25	12,5	51,5	2	53,5	36		
M21893-12-36	19	- 12	3/4"	M 36x1,5	26,75	15	61,5	4,7	60	41		

## JIS STANDARD CONNECTIONS

### M24011/M24012

JIS METRIC FEMALE 60° CONE SEAT (KOMATSU) JIS B 8363

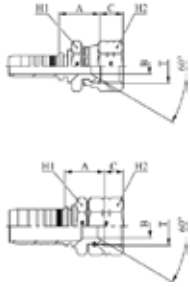

PART. REF.	HOSE BORE			Thread	DIMENSIONS mm							
	DN	Dash	inch		T	B	A	C	H1	H2		
M24011-04-14	6	- 4	1/4"	M 14x1,5		4	23	10,5	19	19		
M24011-04-18	6	- 4	1/4"	M 18x1,5		7	22,5	11,5	24	24		
M24011-05-16	8	- 5	5/16"	M 16x1,5		5,5	22,5	9,3	21	21		
M24011-06-14	10	- 6	3/8"	M 14x1,5		4	23,5	10,5	19	19		
M24011-06-18	10	- 6	3/8"	M 18x1,5		7	23,5	11,5	24	24		
M24011-08-22	12	- 8	1/2"	M 22x1,5		9,3	25	13	27	27		
M24011-10-24	16	- 10	5/8"	M 24x1,5		12,5	26,5	15,1	32	32		
M24011-12-30	19	- 12	3/4"	M 30x1,5		15	31,5	18,3	36	36		
M24011-16-33	25	- 16	1"	M 33x1,5		19,8	33,5	21,3	41	41		
M24011-20-36	31	- 20	1.1/4"	M 36x1,5		19,8	41	20	46	46		
M24012-24-42	38	- 24	1.1/2"	M 42x1,5		26	44	18,8	55	55		

M24011: CRIMPED-BACK NUT / M24012: THRUST-WIRE NUT

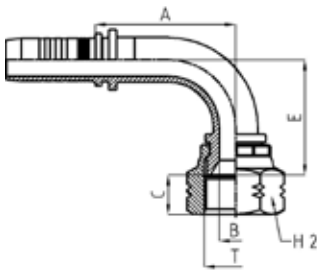

## JIS STANDARD CONNECTIONS

### M24091

90° JIS METRIC FEMALE 60° CONE SEAT

PART. REF.	HOSE BORE			Thread	DIMENSIONS mm							
	DN	Dash	inch		T	B	A	C	E	H2		
M24091-04-14	6	- 4	1/4"	M 14x1,5		4	29	10,5	28,5	19		
M24091-06-18	10	- 6	3/8"	M 18x1,5		7	35,5	11,5	34	24		
M24091-08-22	12	- 8	1/2"	M 22x1,5		9,3	44	13	40	27		
M24091-10-24	16	- 10	5/8"	M 24x1,5		12,5	53,5	15,2	47	32		
M24091-12-30	19	- 12	3/4"	M 30x1,5		15	61,5	18,3	56,5	36		



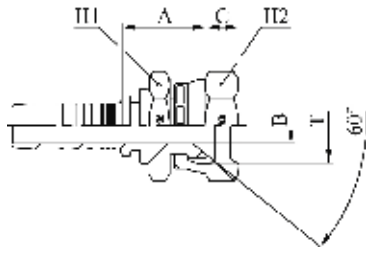

## JIS STANDARD CONNECTIONS

### M23811

JIS BSP FEMALE 60° CONE SEAT (TOYOTA) - JIS B 8363  
(CRIMPED-BACK NUT)

PART. REF.	HOSE BORE			Thread		DIMENSIONS mm						
	DN	Dash	inch			T	B	A	C	H1	H2	
M23811-04-04	6	- 4	1/4"	1/4" - 19		4	18,5	8,3	19	19		
M23811-06-06	10	- 6	3/8"	3/8" - 19		7	23	10	22	22		
M23811-08-08	12	- 8	1/2"	1/2" - 14		9,3	22	11,5	27	27		
M23811-12-12	19	- 12	3/4"	3/4" - 14		15	26	13,5	32	32		
M23811-16-16	25	- 16	1"	1" - 11		19,8	30,5	14,5	38	38		



## JIS STANDARD CONNECTIONS

### M20711/M20712

JIS BSP FEMALE 60° CONE (NISSAN) - JIS B 8363

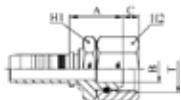

PART. REF.	HOSE BORE			Thread		DIMENSIONS mm						
	DN	Dash	inch			T	B	A	C	H1	H2	
M20711-04-04	6	- 4	1/4"	1/4" - 19		4	22,5	4,5	19	19		
M20711-06-06	10	- 6	3/8"	3/8" - 19		7	24,5	6,4	22	22		
M20711-08-08	12	- 8	1/2"	1/2" - 14		9,3	26,5	6,7	27	27		
M20712-10-08	16	- 10	5/8"	1/2" - 14		9,3	29	6,5	27	27		
M20712-10-12	16	- 10	5/8"	3/4" - 14		15	30,5	9	32	32		
M20711-12-12	19	- 12	3/4"	3/4" - 14		15	30	8,9	32	32		
M20712-16-16	25	- 16	1"	1" - 11		19,8	35,5	10,5	38	38		
M20712-20-20	31	- 20	1.1/4"	1.1/4" - 11		26	44,5	12,5	50	50		

M20711: CRIMPED-BACK NUT / M20712: THRUST-WIRE NUT

## ORIGINAL EQUIPMENT CONNECTIONS

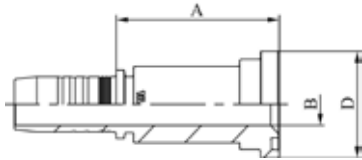

### M24111

#### STRAIGHT KOMATSU FLANGE

PART. REF.	HOSE BORE			Flange	DIMENSIONS mm							
	DN	Dash	inch		Inch	B	A	D				
M24111-08-10	12	- 8	1/2"	5/8"		14	66	34				
M24111-10-10	16	- 10	5/8"	5/8"		14	65,5	34				
M24111-12-10	19	- 12	3/4"	5/8"		14	66,5	34				

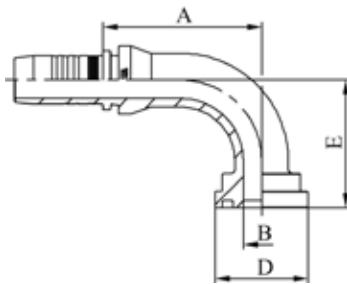

## ORIGINAL EQUIPMENT CONNECTIONS

### M24191

#### 90° KOMATSU FLANGE

PART. REF.	HOSE BORE			Flange	DIMENSIONS mm							
	DN	Dash	inch		Inch	B	A	D	E			
M24191-10-10	16	- 10	5/8"	5/8"		14	56	34	47,5			
M24191-12-10	19	- 12	3/4"	5/8"		14	56	34	47,5			

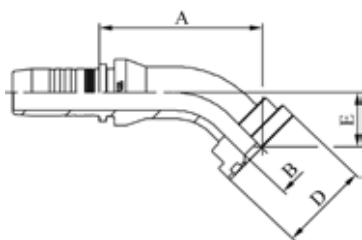

## ORIGINAL EQUIPMENT CONNECTIONS

### M24141

#### 45° KOMATSU FLANGE

PART. REF.	HOSE BORE			Flange	DIMENSIONS mm							
	DN	Dash	inch		Inch	B	A	D	E			
M24141-10-10	16	- 10	5/8"	5/8"		14	61	34	22			

## ORIGINAL EQUIPMENT CONNECTIONS

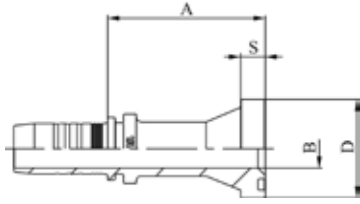

### M23911

#### STRAIGHT SUPERCAT FLANGE

PART. REF.	HOSE BORE			Flange	DIMENSIONS mm						
	DN	Dash	inch		Inch	B	A	D	S		
M23911-12-12	19	- 12	3/4"	3/4"		15	74,5	41,5	14,3		
M23911-12-16	19	- 12	3/4"	1"		19,8	83,5	47,7	14,3		
M23911-16-16	25	- 16	1"	1"		19,8	87	47,7	14,3		
M23911-16-20	25	- 16	1"	1.1/4"		26	92,5	54	14,3		
M23911-20-20	31	- 20	1.1/4"	1.1/4"		26	86	54	14,3		
M23911-24-24	38	- 24	1.1/2"	1.1/2"		32	94	63,6	14,3		

## ORIGINAL EQUIPMENT CONNECTIONS

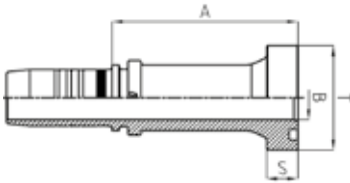

### M23911CT

#### STRAIGHT REALCAT FLANGE

PART. REF.	HOSE BORE			Flange	DIMENSIONS mm						
	DN	Dash	inch		Inch	B	A	D	S		
M23911-16-16CT	25	- 16	1"	1"		19,8	85	47,7	14,3		
M23911-20-20CT	31	- 20	1.1/4"	1.1/4"		26	88,5	54	14,3		
M23911-24-24CT	38	- 24	1.1/2"	1.1/2"		32	93	63,6	14,3		

## ORIGINAL EQUIPMENT CONNECTIONS

### M23991

#### 90° SUPERCAT FLANGE

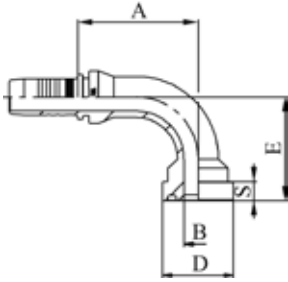

PART. REF.	HOSE BORE			Flange	DIMENSIONS mm						
	DN	Dash	inch		Inch	B	A	D	E	S	
M23991-12-12	19	- 12	3/4"	3/4"	15	64,5	41,5	64,5	14,3		
M23991-16-16	25	- 16	1"	1"	19,8	77,5	47,7	76,5	14,3		
M23991-16-20	25	- 16	1"	1.1/4"	26	75,5	54	80,5	14,3		
M23991-20-20	31	- 20	1.1/4"	1.1/4"	26	85,5	54	87	14,3		
M23991-20-24	31	- 20	1.1/4"	1.1/2"	32	85,5	63,7	93	14,3		

## ORIGINAL EQUIPMENT CONNECTIONS

### M23991CT

#### 90° REALCAT FLANGE

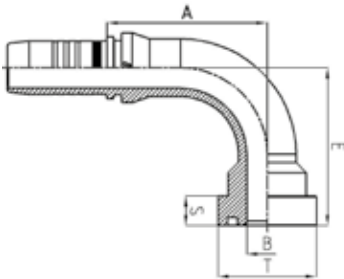

PART. REF.	HOSE BORE			Flange	DIMENSIONS mm						
	DN	Dash	inch		Inch	B	A	D	E	S	
M23991-16-16CT	25	- 16	1"	1"	19,8	77,5	47,7	76,5	14,3		
M23991-16-20CT	25	- 16	1"	1.1/4"	26	75,5	54	80,5	14,3		
M23991-20-20CT	31	- 20	1.1/4"	1.1/4"	26	85,5	54	87	14,3		
M23991-24-24CT	38	- 24	1.1/2"	1.1/2"	32	106	63,7	96	14,3		

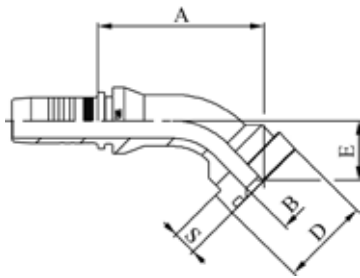

## ORIGINAL EQUIPMENT CONNECTIONS

### M23941

#### 45° SUPERCAT FLANGE

PART. REF.	HOSE BORE			Flange	DIMENSIONS mm						
	DN	Dash	inch		Inch	B	A	D	E	S	
M23941-12-12	19	- 12	3/4"	3/4"	15	77	41,5	32	14,3		
M23941-16-16	25	- 16	1"	1"	19,8	89,5	47,7	36,5	14,3		
M23941-16-20	25	- 16	1"	1"	26	92,5	54	40,5	14,3		
M23941-20-20	31	- 20	1.1/4"	1.1/4"	26	99	54	41,5	14,3		
M23941-24-24	38	- 24	1.1/2"	1.1/2"	32	119	63,6	45,5	14,3		

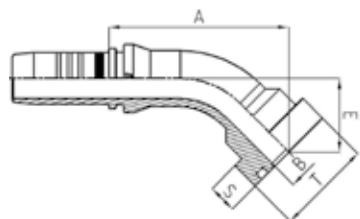

## ORIGINAL EQUIPMENT CONNECTIONS

### M23941CT

#### 45° REALCAT FLANGE

PART. REF.	HOSE BORE			Flange	DIMENSIONS mm						
	DN	Dash	inch		Inch	B	A	D	E	S	
M23941-16-16CT	25	- 16	1"	1"	19,8	89,5	47,7	36,5	14,3		
M23941-16-20CT	25	- 16	1"	1.1/4"	26	93	54	40,5	14,3		
M23941-20-20CT	31	- 20	1.1/4"	1.1/4"	26	99	54	41,5	14,3		
M23941-24-24CT	38	- 24	1.1/2"	1.1/2"	32	119	63,7	45	14,3		

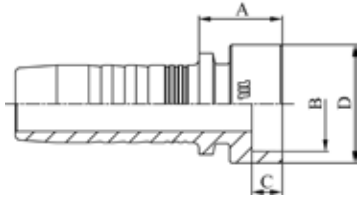

TAIL

**M..IP..**

**BRAZING TAIL**

FITTINGS

F 2-80

PART. REF.	HOSE BORE			DIMENSIONS mm							
	DN	Dash	inch	B	A	C	D				
M03IP06	5	- 3	3/16"	6	11,5	5	10				
M04IP08	6	- 4	1/4"	8	13	5	12				
M05IP10	8	- 5	5/16"	10	13,5	6	14				
M06IP14	10	- 6	3/8"	14	13,5	6	18				
M06IP12	10	- 6	3/8"	12	13,5	6	16				
M08IP15	12	- 8	1/2"	15	14	6	20				
M08IP16	12	- 8	1/2"	16	14	6	20				
M10IP18	16	- 10	5/8"	18	15	7	23				
M12IP22	19	- 12	3/4"	22	16	7	26				
M16IP28	25	- 16	1"	28	18,5	8	34				
M20IP35	31	- 20	1.1/4"	35	20,5	9	40				
M24IP40	38	- 24	1.1/2"	40	21,5	9	50				
M32IP50	51	- 32	2"	50	23	10	60				
M40IP60	63	- 40	2.1/2"	61	19	7	73				
M48IP70	76	- 48	3"	70	38	10	89				

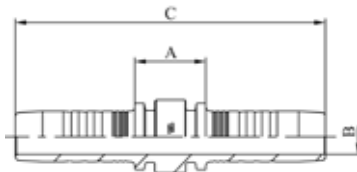

DOUBLE CONNECTOR

**M10050**

**DOUBLE CONNECTOR**

PART. REF.	HOSE BORE			DIMENSIONS mm							
	DN	Dash	inch	B	A	C					
M10050-03-03	5	- 3	3/16"	3	15,5	58,2					
M10050-04-04	6	- 4	1/4"	4	14	69					
M10050-05-05	8	- 5	5/16"	5,5	14	70					
M10050-06-06	10	- 6	3/8"	7	14,5	73,5					
M10050-08-08	12	- 8	1/2"	9,3	15,5	77,9					
M10050-10-10	16	- 10	5/8"	12,5	15,5	84					
M10050-12-12	19	- 12	3/4"	15	18,5	91,5					
M10050-16-16	25	- 16	1"	19,8	22,5	119					
M10050-20-20	31	- 20	1.1/4"	26	23	128,1					
M10050-24-24	38	- 24	1.1/2"	32	23,5	147,5					

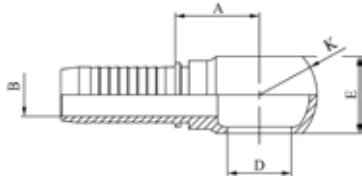

## BANJO CONNECTIONS

### O20910

METRIC BANJO - DIN 7642

PART. REF.	HOSE BORE			Thread		DIMENSIONS mm						
	DN	Dash	inch			T	B	A	D	E		
O20910-04-12	6	- 4	1/4"	M 12x1,5		4,4	22,5	12	12	20		
O20910-04-14	6	- 4	1/4"	M 14x1,5		4,4	23,5	14	14	24		
O20910-05-14	8	- 5	5/16"	M 14x1,5		5,6	23,5	14	14	24		
O20910-06-14	10	- 6	3/8"	M 14x1,5		7,1	25	14	14	24		
O20910-06-16	10	- 6	3/8"	M 16x1,5		7,1	25	16	16	28		
O20910-06-18	10	- 6	3/8"	M 18x1,5		7,1	27	18	20	32		
O20910-08-18	12	- 8	1/2"	M 18x1,5		9,8	28	18	20	32		
O20910-08-22	12	- 8	1/2"	M 22x1,5		9,8	31	22	25	39		
O20910-10-22	16	- 10	5/8"	M 22x1,5		12,7	31	22	25	39		
O20910-12-26	19	- 12	3/4"	M 26x1,5		15,5	34,5	26	30	46		

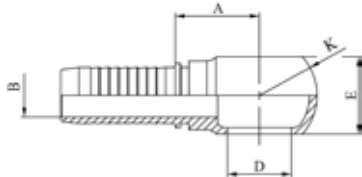

## BANJO CONNECTIONS

### O20310

BSP BANJO

PART. REF.	HOSE BORE			Thread		DIMENSIONS mm						
	DN	Dash	inch			T	B	A	D	E		
O20310-04-04	6	- 4	1/4"	1/4" - 19		4,4	22	13,2	15	24		
O20310-04-06	6	- 4	1/4"	3/8" - 19		4,4	23,5	16,7	18	28		
O20310-05-04	8	- 5	5/16"	1/4" - 19		5	23	13,2	14	24		
O20310-05-06	8	- 5	5/16"	3/8" - 19		5,6	23	16,7	20	29		
O20310-06-06	10	- 6	3/8"	3/8" - 19		7	24,5	16,7	20	29		
O20310-06-08	10	- 6	3/8"	1/2" - 19		7,1	27	21	25	38		
O20310-08-08	12	- 8	1/2"	1/2" - 14		9,8	27,5	21	25	38		
O20310-10-10	16	- 10	5/8"	5/8" - 14		12,7	29,5	23	27	40		
O20310-12-12	19	- 12	3/4"	3/4" - 14		15,5	36,5	26,5	31	48		
O20310-16-16	25	- 16	1"	1" - 11		20,5	40,5	33,3	42	60		

BOLT

**O80810**

METRIC BOLT - DIN 7643

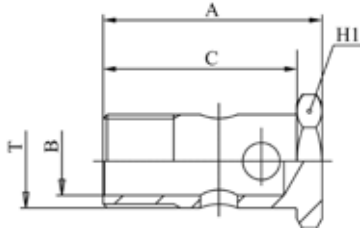

PART. REF.	HOSE BORE			Thread	DIMENSIONS mm							
	DN	Dash	inch		T	B	A	C	H1			
O80810-12				M 12x1,5		7	29	24	17			
O80810-14				M 14x1,5		9	31	26	19			
O80810-16				M 16x1,5		11	33	28	22			
O80810-18				M 18x1,5		13	37	32	24			
O80810-22				M 22x1,5		16	45	39	27			
O80810-26				M 26x1,5		20	51	45	32			

BOLT

**O80210**

BSP BOLT

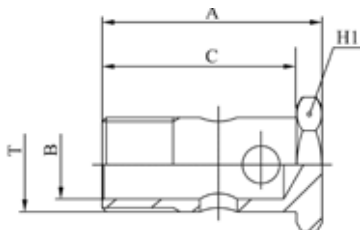

PART. REF.	HOSE BORE			Thread	DIMENSIONS mm							
	DN	Dash	inch		T	B	A	C	H1			
O80210-04				1/4" - 19		6	34,5	28,5	17			
O80210-06				3/8" - 19		9	45,5	38,5	22			
O80210-08				1/2" - 14		13	52	44	27			
O80210-10				5/8" - 14		15	56,5	48,5	30			
O80210-12				3/4" - 14		18	64	54	32			
O80210-16				1" - 11		24	77,5	68,5	41			





# INTERLOCK PLUS



FITTING CODE	SECTION	PAGE
JO29	3	31
M01500	3	1
M01600	3	1
M01800-M01810	3	2
M30050	3	30
M30510	3	2
M31210	3	18
M32410	3	6
M32510	3	4
M32810	3	11
M33010	3	11
M40812	3	3
M40842	3	4
M40892	3	3
M41243 LONG DROP	3	20
M41293 LONG DROP	3	20
M41612-M41613	3	18
M41642-M41643	3	19
M41692-M41693	3	19
M42411	3	7
M42412	3	7
M42441	3	9
M42442	3	10
M42443	3	10
M42491	3	8
M42492	3	8
M42493	3	9
M42512	3	5
M42542	3	6
M42592	3	5
M43310	3	12

FITTING CODE	SECTION	PAGE
M43320	3	12
M43330	3	13
M43340	3	13
M43390	3	14
M43610	3	15
M43630	3	16
M43640	3	16
M43660	3	17
M43690	3	17
M43710	3	21
M43740	3	21
M43790	3	21
M43910	3	22
M43910CT	3	22
M43920	3	23
M43930	3	23
M43940	3	24
M43940CT	3	24
M43960	3	25
M43970	3	25
M43990	3	26
M43990 LONG DROP	3	27
M43990CT	3	26
M44492 LONG DROP	3	10
M48410	3	27
M48490	3	28
M48510	3	28
M48540	3	29
M48590	3	29
M49510WL	3	30

## INTERLOCK PLUS

DN	5	6	8	10	12	16	19	25	31	38	51	60	63	76	89	102
Inch	3/16"	1/4"	5/16"	3/8"	1/2"	5/8"	3/4"	1"	1 1/4"	1 1/2"	2"	2 3/8"	2 1/2"	3"	3 1/2"	4"
Size	-03	-04	-05	-06	-08	-10	-12	-16	-20	-24	-32	-38	-40	-48	-56	-64

### FERRULES

M01500																	
M01600																	
M01800 / M01810																	

### FITTINGS

BSP																	
SAE (JIC)																	
SAE (ORFS)																	
SAE																	
SAE (NPTF-NPSM)																	
SAE FLANGE CODE 61																	
SAE FLANGE CODE 62																	
DIN METRIC 24° CONE HEAVY TYPE																	
ORIGINAL EQUIPMENT CONNECTIONS																	
XTRAFRANGE																	

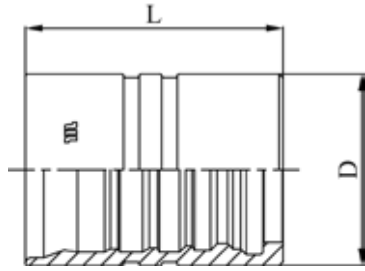

FERRULE

**M01500**

**DOUBLE SKIVE FERRULE FOR HEAVY DUTY SPIRAL HOSES (4 PLY)**

PART. REF.	HOSE BORE			DIMENSIONS mm							
	DN	Dash	inch			D	L				
M01500-10	16	- 10	5/8"			35	40,9				
M01500-12	19	- 12	3/4"			40	51,4				
M01500-16	25	- 16	1"			48	64,5				
M01500-20	31	- 20	1.1/4"			57	84				
M01500-24	38	- 24	1.1/2"			64,3	94				
M01500-32	51	- 32	2"			83,5	107				
M01500-40	63	- 40	2.1/2"			100	135				
M01500-48	76	- 48	3"			107	125				

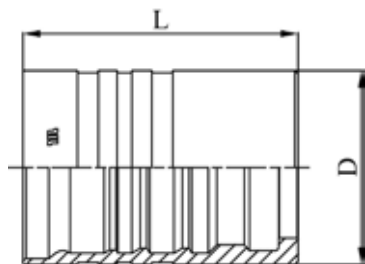

FERRULE

**M01600**

**DOUBLE SKIVE FERRULE FOR HEAVY DUTY SPIRAL HOSES (6 PLY)**

PART. REF.	HOSE BORE			DIMENSIONS mm							
	DN	Dash	inch			D	L				
M01600-20	31	- 20	1.1/4"			60	85				
M01600-24	38	- 24	1.1/2"			69	96				

FERRULE

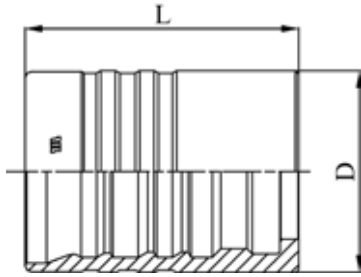

## M01800/M01810

DOUBLE SKIVE FERRULE FOR EXTRA DUTY SPIRAL HOSES (6 PLY)

FITTINGS F 3-2

PART. REF.	HOSE BORE			DIMENSIONS mm							
	DN	Dash	inch			D	L				
M01800-20	31	- 20	1.1/4"			65	88,2				
M01800-32	51	- 32	2"			86,5	108				
M01810-40	63	- 40	2.1/2"			103	135				
M01810-48	76	- 48	3"			113,5	125				

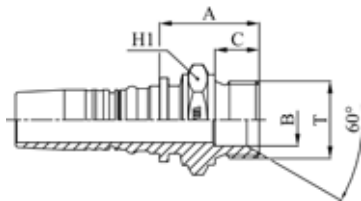

BS STANDARD CONNECTIONS

## M30510

BSP MALE PARALLEL 60° CONE SEAT - BS5200 / ISO 8434-6

PART. REF.	HOSE BORE			Thread	DIMENSIONS mm						
	DN	Dash	inch		T	B	A	C	H1		
M30510-12-12	19	- 12	3/4"	3/4" - 14		17	37	16	32		
M30510-12-16	19	- 12	3/4"	1" - 11		22,5	43	19	41		
M30510-16-16	25	- 16	1"	1" - 11		22,5	43	19	41		
M30510-16-20	25	- 16	1"	1.1/4" - 11		28,5	48	20	50		
M30510-20-20	31	- 20	1.1/4"	1.1/4" - 11		28,5	50,5	20	50		
M30510-24-24	38	- 24	1.1/2"	1.1/2" - 11		33,5	54,5	22	55		
M30510-32-32	51	- 32	2"	2" - 11		42	58	25	70		

## BS STANDARD CONNECTIONS

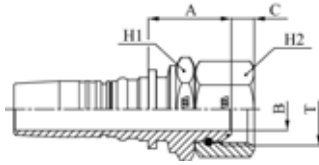

### M40812

**BSP O-RING FEMALE 60° CONE - BS5200 / ISO 12151-6 (THRUST-WIRE NUT)**

PART. REF.	HOSE BORE			Thread		DIMENSIONS mm						
	DN	Dash	inch			T	B	A	C	H1	H2	
M40812-12-12	19	- 12	3/4"	3/4" - 14		14,5	39	8,5	32	32		
M40812-12-16	19	- 12	3/4"	1" - 11		19	36,5	10,6	32	41		
M40812-16-12	25	- 16	1"	3/4" - 14		15	35	8,5	41	32		
M40812-16-16	25	- 16	1"	1" - 11		19,5	44,5	10,6	41	41		
M40812-16-20	25	- 16	1"	1.1/4" - 11		26,1	41	10,5	41	50		
M40812-20-16	31	- 20	1.1/4"	1" - 11		19	44,5	10,6	50	41		
M40812-20-20	31	- 20	1.1/4"	1.1/4" - 11		26,1	52,5	10,5	50	50		
M40812-20-24	31	- 20	1.1/4"	1.1/2" - 11		32,1	46	12,5	50	60		
M40812-24-20	38	- 24	1.1/2"	1.1/4" - 11		26,1	48,5	10,5	60	50		
M40812-24-24	38	- 24	1.1/2"	1.1/2" - 11		32,1	51,5	12,5	60	60		
M40812-32-32	51	- 32	2"	2" - 11		42	51,5	16,1	70	70		

## BS STANDARD CONNECTIONS

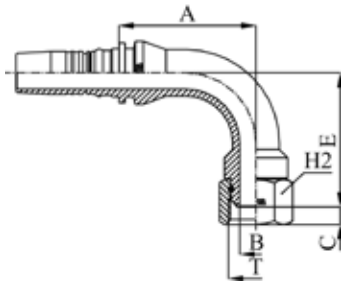

### M40892

**90° BSP O-RING FEMALE SWEPT ELBOW 60° CONE BS5200 / ISO 12151-6 (THRUST-WIRE NUT)**

PART. REF.	HOSE BORE			Thread		DIMENSIONS mm						
	DN	Dash	inch			T	B	A	C	E	H2	
M40892-12-12	19	- 12	3/4"	3/4" - 14		14,5	72,5	8,5	70	32		
M40892-12-16	19	- 12	3/4"	1" - 11		19	72,5	10,6	71	41		
M40892-16-16	25	- 16	1"	1" - 11		19,5	82	10,6	80,5	41		
M40892-16-20	25	- 16	1"	1.1/4" - 11		26,1	95	10,5	78,5	50		
M40892-20-20	31	- 20	1.1/4"	1.1/4" - 11		26,1	98,5	10,5	98	50		
M40892-20-24	31	- 20	1.1/4"	1.1/2" - 11		32,1	98,5	12,5	84,5	60		
M40892-24-24	38	- 24	1.1/2"	1.1/2" - 11		32,1	111,5	12,5	109	60		
M40892-32-32	51	- 32	2"	2" - 11		42	143	16,1	140,5	70		

## BS STANDARD CONNECTIONS

### M40842

45° BSP O-RING FEMALE SWEPT ELBOW 60° CONE BS5200 / ISO 12151-6 (THRUST-WIRE NUT)

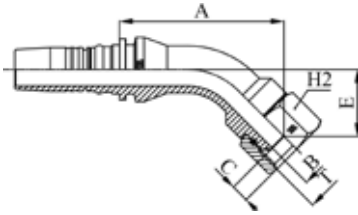

PART. REF.	HOSE BORE			Thread		DIMENSIONS mm						
	DN	Dash	inch			T	B	A	C	E	H2	
M40842-12-12	19	- 12	3/4"	3/4" - 14		14,5	88	8,5	35	32		
M40842-12-16	19	- 12	3/4"	1" - 11		19	89,5	10,6	36,5	41		
M40842-16-12	25	- 16	1"	3/4" - 14		15	105,5	8,5	36	32		
M40842-16-16	25	- 16	1"	1" - 11		19,5	97	10,6	40	41		
M40842-16-20	25	- 16	1"	1.1/4" - 11		26,1	108,5	10,5	38	50		
M40842-20-16	31	- 20	1.1/4"	1" - 11		19	118	10,6	47,5	41		
M40842-20-20	31	- 20	1.1/4"	1.1/4" - 11		26,1	120	10,5	49,5	50		
M40842-20-24	31	- 20	1.1/4"	1.1/2" - 11		32,1	114,5	12,5	40	60		
M40842-24-24	38	- 24	1.1/2"	1.1/2" - 11		32,1	126,5	12,5	50	60		
M40842-32-32	51	- 32	2"	2" - 11		42	162,5	16,1	66,5	70		

## SAE STANDARD CONNECTIONS

### M32510

JIC MALE 37° CONE - SAE J516 / ISO 12151-5

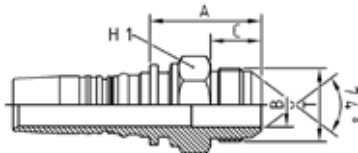

PART. REF.	HOSE BORE			Thread		DIMENSIONS mm					
	DN	Dash	inch			T	B	A	C	H1	
M32510-10-10	16	- 10	5/8"	7/8" - 14		12	41	19,5	27		
M32510-12-12	19	- 12	3/4"	1.1/16" - 12		15	45,5	22	32		
M32510-16-16	25	- 16	1"	1.5/16" - 12		20	50,5	23	38		
M32510-16-20	25	- 16	1"	1.5/8" - 12		26	57	24,3	42		
M32510-20-20	31	- 20	1.1/4"	1.5/8" - 12		26,1	66	24,3	46		
M32510-24-24	38	- 24	1.1/2"	1.7/8" - 12		32,1	64	27,5	50		
M32510-32-32	51	- 32	2"	2.1/2" - 12		42	81	34	70		



## SAE STANDARD CONNECTIONS

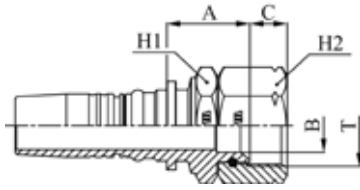

### M42512

**JIC FEMALE 37° CONE SEAT - SAE J516 / ISO 12151-5 (THRUST-WIRE NUT)**

PART. REF.	HOSE BORE			Thread		DIMENSIONS mm						
	DN	Dash	inch			T	B	A	C	H1	H2	
M42512-12-12	19	- 12	3/4"	1.1/16" - 12		15	36	14,2	32	32		
M42512-12-16	19	- 12	3/4"	1.5/16" - 12		21,7	32,5	15,2	41	41		
M42512-16-16	25	- 16	1"	1.5/16" - 12		21,7	40,5	15,2	41	41		
M42512-16-20	25	- 16	1"	1.5/8" - 12		26,1	44	16,2	50	50		
M42512-20-20	31	- 20	1.1/4"	1.5/8" - 12		26,1	51,5	16,2	50	50		
M42512-20-24	31	- 20	1.1/4"	1.7/8" - 12		30,5	51	18,8	55	60		
M42512-24-24	38	- 24	1.1/2"	1.7/8" - 12		31	54,5	18,8	55	60		
M42512-32-32	51	- 32	2"	2.1/2" - 12		42	54	24	70	75		

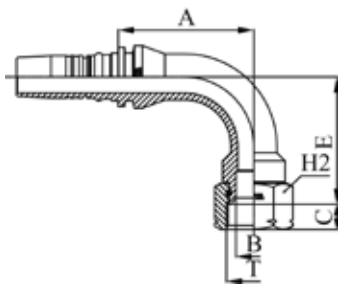

## SAE STANDARD CONNECTIONS

### M42592

**90° JIC FEMALE SWEPT ELBOW 37° CONE SEAT - SAE J516 / ISO 12151-5 (THRUST-WIRE NUT)**

PART. REF.	HOSE BORE			Thread		DIMENSIONS mm						
	DN	Dash	inch			T	B	A	C	E	H2	
M42592-12-12	19	- 12	3/4"	1.1/16" - 12		15	72,5	14,2	66	32		
M42592-12-16	19	- 12	3/4"	1.5/16" - 12		21,7	72,5	15,2	71,5	41		
M42592-16-16	25	- 16	1"	1.5/16" - 12		21,7	82,5	15,2	77,5	41		
M42592-16-20	25	- 16	1"	1.5/8" - 12		26,1	90,5	16,2	76,5	50		
M42592-20-20	31	- 20	1.1/4"	1.5/8" - 12		26,1	98,5	16,2	92	50		
M42592-20-24	31	- 20	1.1/4"	1.7/8" - 12		32,1	101,5	18,8	108	60		
M42592-24-24	38	- 24	1.1/2"	1.7/8" - 12		32,1	111,5	18,8	106	60		
M42592-32-32	51	- 32	2"	2.1/2" - 12		42	144,5	24	137	75		

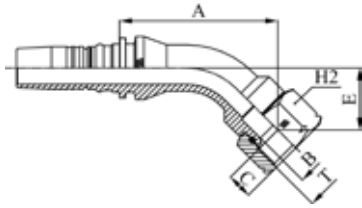

## SAE STANDARD CONNECTIONS

### M42542

45° JIC FEMALE SWEPT ELBOW 37° CONE SEAT - SAE J516 / ISO 12151-5 (THRUST-WIRE NUT)

PART. REF.	HOSE BORE			Thread		DIMENSIONS mm						
	DN	Dash	inch			T	B	A	C	E	H2	
M42542-12-12	19	- 12	3/4"	1.1/16" - 12		15	86	14,2	33	32		
M42542-16-16	25	- 16	1"	1.5/16" - 12		21,7	95	15,2	37	41		
M42542-16-20	25	- 16	1"	1.5/8" - 12		26,1	102,5	16,2	36,5	50		
M42542-20-20	31	- 20	1.1/4"	1.5/8" - 12		26,1	115,5	16,2	45	50		
M42542-24-24	38	- 24	1.1/2"	1.7/8" - 12		32,1	126,5	18,8	50	60		
M42542-32-32	51	- 32	2"	2.1/2" - 12		42	161,5	24	63,5	75		

FITTINGS F 3-6

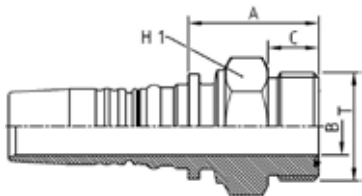

## SAE STANDARD CONNECTIONS

### M32410

ORFS MALE - SAE J516 / ISO 12151-1

PART. REF.	HOSE BORE			Thread		DIMENSIONS mm					
	DN	Dash	inch			T	B	A	C	H1	
M32410-10-08	16	- 10	5/8"	13/16" - 16		9,3	33	12,8	27		
M32410-10-10	16	- 10	5/8"	1" - 14		12	36	15,5	27		
M32410-10-12	16	- 10	5/8"	1.3/16" - 12		15	39	17	32		
M32410-12-12	19	- 12	3/4"	1.3/16" - 12		14,5	40,5	17	32		
M32410-12-16	19	- 12	3/4"	1.7/16" - 12		19,8	42,5	17,5	38		
M32410-16-16	25	- 16	1"	1.7/16" - 12		19,5	45	17,5	41		
M32410-16-20	25	- 16	1"	1.11/16" - 12		25	48	17,5	46		
M32410-20-16	31	- 20	1.1/4"	1.7/16" - 12		19,5	47	17,5	50		
M32410-20-20	31	- 20	1.1/4"	1.11/16" - 12		25	50,5	17,5	46		
M32410-24-24	38	- 24	1.1/2"	2" - 12		31	53	17,5	55		
M32410-32-24	51	- 32	2"	2" - 12		31	53	17,5	70		

## SAE STANDARD CONNECTIONS

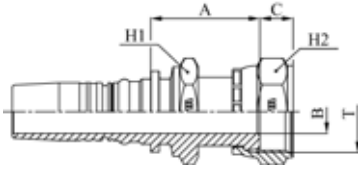

### M42411

**ORFS FEMALE - SAE J516 / ISO 12151-1 PULLBACK TYPE (CRIMPED BACK-NUT)**

PART. REF.	HOSE BORE			Thread		DIMENSIONS mm						
	DN	Dash	inch			T	B	A	C	H1	H2	
M42411-10-10	16	- 10	5/8"	1" - 14		11,5	40,5	12,5	24	30		
M42411-12-12	19	- 12	3/4"	1.3/16" - 12		14,5	48	13,5	32	36		
M42411-12-16	19	- 12	3/4"	1.7/16" - 12		19	50	13,5	36	41		
M42411-16-12	25	- 16	1"	1.3/16" - 12		14,3	50	13,5	41	36		
M42411-16-16	25	- 16	1"	1.7/16" - 12		19,5	51,5	13,5	41	41		
M42411-16-20	25	- 16	1"	1.11/16" - 12		26	48,5	14,8	41	50		
M42411-20-20	31	- 20	1.1/4"	1.11/16" - 12		25	55	14,8	50	50		
M42411-24-24	38	- 24	1.1/2"	2" - 12		31	58	15,8	60	60		

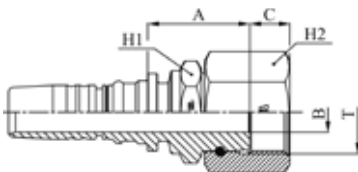

## SAE STANDARD CONNECTIONS

### M42412

**ORFS FEMALE - SAE J516 / ISO 12151-1 HEAVY TYPE (THRUST-WIRE NUT)**

PART. REF.	HOSE BORE			Thread		DIMENSIONS mm						
	DN	Dash	inch			T	B	A	C	H1	H2	
M42412-12-12	19	- 12	3/4"	1.3/16" - 12		14,5	37	14,1	32	36		
M42412-12-16	19	- 12	3/4"	1.7/16" - 12		19,8	41	15	41	46		
M42412-16-16	25	- 16	1"	1.7/16" - 12		19,5	42	15	41	46		
M42412-16-20	25	- 16	1"	1.11/16" - 12		26	50	15,1	46	55		
M42412-20-20	31	- 20	1.1/4"	1.11/16" - 12		25	52	15,1	50	55		
M42412-20-24	31	- 20	1.1/4"	2" - 12		31	53	15	55	60		
M42412-24-24	38	- 24	1.1/2"	2" - 12		31	55	15	60	60		

## SAE STANDARD CONNECTIONS

### M42491

90° ORFS FEMALE SWEPT ELBOW - SAE J516 / ISO 12151-1  
(CRIMPED BACK-NUT)

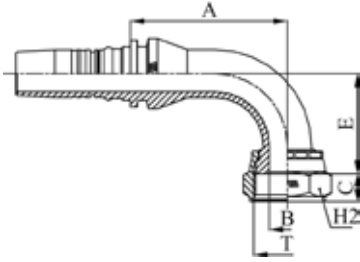

PART. REF.	HOSE BORE			Thread		DIMENSIONS mm						
	DN	Dash	inch			T	B	A	C	E	H2	
M42491-10-12	16	- 10	5/8"	1.3/16" - 12		14,3	51	13,5	47	36		
M42491-12-12	19	- 12	3/4"	1.3/16" - 12		14,5	65	13,5	48	36		
M42491-12-12109	19	- 12	3/4"	1.3/16" - 12		14,5	65	13,5	109	36		
M42491-12-16	19	- 12	3/4"	1.7/16" - 12		19	70	13,5	53	41		
M42491-16-16	25	- 16	1"	1.7/16" - 12		19,5	85	13,5	57	41		
M42491-16-16128	25	- 16	1"	1.7/16" - 12		19,5	85	13,5	128	41		
M42491-16-20	25	- 16	1"	1.11/16" - 12		24	85	14,8	58	50		
M42491-20-20	31	- 20	1.1/4"	1.11/16" - 12		25	98,5	14,8	65	50		
M42491-24-24	38	- 24	1.1/2"	2" - 12		31	115,5	15,8	79,5	60		

## SAE STANDARD CONNECTIONS

### M42492

90° ORFS FEMALE SWEPT ELBOW - SAE J516 / ISO 12151-1 HEAVY  
TYPE (THRUST-WIRE-NUT)

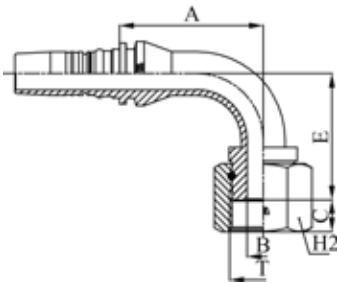

PART. REF.	HOSE BORE			Thread		DIMENSIONS mm						
	DN	Dash	inch			T	B	A	C	E	H2	
M42492-12-12	19	- 12	3/4"	1.3/16" - 12		14,5	72,5	14,1	70,5	36		
M42492-16-16	25	- 16	1"	1.7/16" - 12		19,5	82,5	15	84,5	46		
M42492-20-20	31	- 20	1.1/4"	1.11/16" - 12		25	98,5	15,1	98	55		
M42492-24-24	38	- 24	1.1/2"	2" - 12		31	111,5	15	109	60		

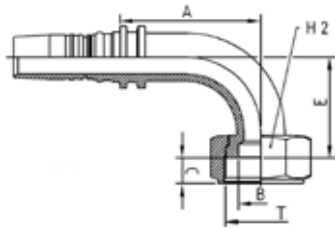

## SAE STANDARD CONNECTIONS

### M42493

90° ORFS FEMALE SWEPT ELBOW - SAE J516 / ISO 12151-1 (SLIP-ON NUT)

PART. REF.	HOSE BORE			Thread		DIMENSIONS mm						
	DN	Dash	inch			T	B	A	C	E	H2	
M42493-12-16	19	- 12	3/4"	1.7/16" - 12		19,8	67	14,8	53	41		
M42493-16-20	25	- 16	1"	1.11/16" - 12		26	81,5	14,8	58,5	50		
M42493-20-24	31	- 20	1.1/4"	2" - 12		32	100	14,8	70,5	60		

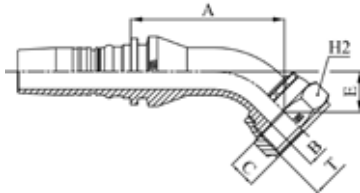

## SAE STANDARD CONNECTIONS

### M42441

45° ORFS FEMALE SWEPT ELBOW - SAE J516 / ISO 12151-1 (CRIMPED BACK-NUT)

PART. REF.	HOSE BORE			Thread		DIMENSIONS mm						
	DN	Dash	inch			T	B	A	C	E	H2	
M42441-10-12	16	- 10	5/8"	1.3/16" - 12		14,3	56	13,5	21,5	36		
M42441-12-12	19	- 12	3/4"	1.3/16" - 12		14,5	69	13,5	21,5	36		
M42441-12-16	19	- 12	3/4"	1.7/16" - 12		19	77,5	13,5	25	41		
M42441-16-16	25	- 16	1"	1.7/16" - 12		19,5	86	13,5	24	41		
M42441-20-20	31	- 20	1.1/4"	1.11/16" - 12		25	96,5	14,8	26	50		
M42441-24-24	38	- 24	1.1/2"	2" - 12		31	112	15,8	31,5	60		

## SAE STANDARD CONNECTIONS

### M42442

45° ORFS FEMALE SWEPT ELBOW - SAE J516 / ISO 12151-1 HEAVY TYPE (THRUST-WIRE-NUT)

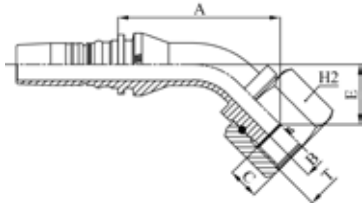

PART. REF.	HOSE BORE			Thread	DIMENSIONS mm						
	DN	Dash	inch		T	B	A	C	E	H2	
M42442-12-12	19	- 12	3/4"	1.3/16" - 12	14,5	89	14	36	36		
M42442-16-16	25	- 16	1"	1.7/16" - 12	19,5	100	15	42,5	46		
M42442-20-20	31	- 20	1.1/4"	1.11/16" - 12	25	119,5	15,1	49,5	55		
M42442-24-24	38	- 24	1.1/2"	2" - 12	31	128,5	15	52	60		

## SAE STANDARD CONNECTIONS

### M42443

45° ORFS FEMALE SWEPT ELBOW - SAE J516 / ISO 12151-1 (SLIP-ON NUT)

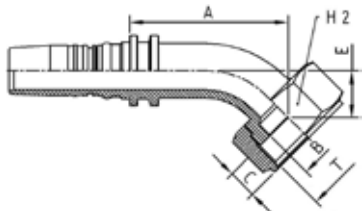

PART. REF.	HOSE BORE			Thread	DIMENSIONS mm						
	DN	Dash	inch		T	B	A	C	E	H2	
M42443-12-16	19	- 12	3/4"	1.7/16" - 12	19,8	71	14,8	23,5	41		
M42443-16-20	25	- 16	1"	1.11/16" - 12	26	81	14,8	24	50		
M42443-20-24	31	- 20	1.1/4"	2" - 12	32	99	14,8	29	60		

## SAE STANDARD CONNECTIONS

### M44492 LONG DROP

90° ORFS FEMALE LONG DROP ELBOW - SAE J516 / ISO 12151-1 (THURST- WIRE NUT)

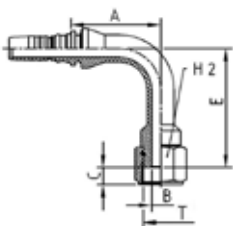

PART. REF.	HOSE BORE			Thread	DIMENSIONS mm						
	DN	Dash	inch		T	B	A	C	E	H2	
M44492-12-12	19	- 12	3/4"	1.3/16" - 12	14,5	72,5	14,1	96	36		
M44492-20-20	31	- 20	1.1/4"	1.11/16" - 12	25	98,5	15,1	129	55		

## SAE STANDARD CONNECTIONS

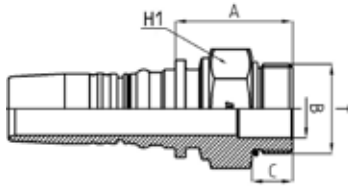

### M33010

SAE MALE O-RING BOSS TYPE - SAE J516 / ISO 11926

PART. REF.	HOSE BORE			Thread		DIMENSIONS mm						
	DN	Dash	inch			T	B	A	C			
M33010-12-12	19	- 12	3/4"	1.1/16" - 12		15,5	42	15,1	32			
M33010-16-16	25	- 16	1"	1.5/16" - 12		21,5	43,5	15,1	38			
M33010-20-20	31	- 20	1.1/4"	1.5/8" - 12		27,5	47,5	15,1	46			

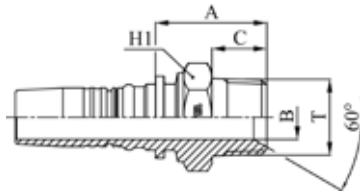

## SAE STANDARD CONNECTIONS

### M32810

NPTF MALE 60° CONE SEAT - SAE J516/J514

PART. REF.	HOSE BORE			Thread		DIMENSIONS mm						
	DN	Dash	inch			T	B	A	C			
M32810-10-12	16	- 10	5/8"	3/4" - 14		16	40,7	19,2	27			
M32810-12-12	19	- 12	3/4"	3/4" - 14		16	42,9	19,2	32			
M32810-16-16	25	- 16	1"	1" - 11,5		19,5	50,5	24,2	38			
M32810-20-20	31	- 20	1.1/4"	1.1/4" - 11,5		26,1	61	25	46			
M32810-24-24	38	- 24	1.1/2"	1.1/2" - 11,5		32,1	62,5	26	50			
M32810-24-32	38	- 24	1.1/2"	2" - 11,5		42	67	26,5	70			
M32810-32-32	51	- 32	2"	2" - 11,5		42	67	26,5	70			
M32810-40-40	63	- 40	2.1/2"	2.1/2" - 8		51,5	94,5	43	80			
M32810-48-48	76	- 48	3"	3" - 8		62,5	123,5	51,5	100			

## SAE STANDARD CONNECTIONS

### M43310

ISO/SAE CODE 61 FLANGE - SAE J516 / ISO 12151-3

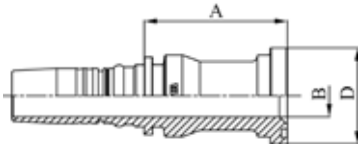

PART. REF.	HOSE BORE			Flange	DIMENSIONS mm						
	DN	Dash	inch		Inch	B	A	D			
M43310-10-16	16	- 10	5/8"	1"		20	64	44,6			
M43310-12-12	19	- 12	3/4"	3/4"		16	60	38			
M43310-12-16	19	- 12	3/4"	1"		20	65,5	44,6			
M43310-16-12	25	- 16	1"	3/4"		16	67	38			
M43310-16-16	25	- 16	1"	1"		20	66,5	44,6			
M43310-16-20	25	- 16	1"	1.1/4"		26,1	73	51			
M43310-20-20	31	- 20	1.1/4"	1.1/4"		26,1	75	51			
M43310-20-24	31	- 20	1.1/4"	1.1/2"		32,1	80	60,5			
M43310-24-24	38	- 24	1.1/2"	1.1/2"		32,1	80,5	60,5			
M43310-24-32	38	- 24	1.1/2"	2"		42	88,5	71,6			
M43310-32-24	38	- 24	1.1/2"	2"		32,1	104	60,5			
M43310-32-32	51	- 32	2"	2"		42	82,5	71,6			
M43310-40-40	63	- 40	2.1/2"	2.1/2"		51,5	92,5	84,3			
M43310-48-48	76	- 48	3"	3"		62,5	101	101,6			

## SAE STANDARD CONNECTIONS

### M43320

22,5° ISO/SAE CODE 61 FLANGE - SAE J516 / ISO 12151-3

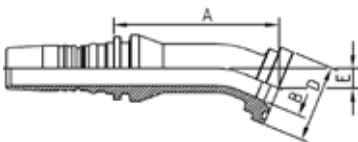

PART. REF.	HOSE BORE			Flange	DIMENSIONS mm						
	DN	Dash	inch		Inch	B	A	D	E		
M43320-16-16	25	- 16	1"	1"		20	94,5	44,6	11,5		



## SAE STANDARD CONNECTIONS

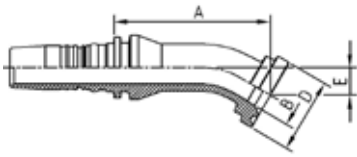

### M43330

30° ISO/SAE CODE 61 FLANGE - SAE J516 / ISO 12151-3

PART. REF.	HOSE BORE			Flange	DIMENSIONS mm						
	DN	Dash	inch		Inch	B	A	D	E		
M43330-16-16	25	- 16	1"	1"	20	93	44,6	16,5			
M43330-20-20	31	- 20	1.1/4"	1.1/4"	26,1	106,5	51	17,5			
M43330-24-24	38	- 24	1.1/2"	1.1/2"	32,1	118	60,5	20			
M43330-32-32	51	- 32	2"	2"	42	137	71,6	22			

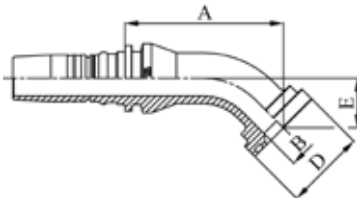

## SAE STANDARD CONNECTIONS

### M43340

45° ISO/SAE CODE 61 FLANGE - SAE J516 / ISO 12151-3

PART. REF.	HOSE BORE			Flange	DIMENSIONS mm						
	DN	Dash	inch		Inch	B	A	D	E		
M43340-12-12	19	- 12	3/4"	3/4"	16	75,5	38	26			
M43340-12-16	19	- 12	3/4"	1"	20	76	44,6	23			
M43340-16-16	25	- 16	1"	1"	20	87	44,6	27,5			
M43340-16-16032	25	- 16	1"	1"	20	92	44,5	32			
M43340-16-20	25	- 16	1"	1.1/4"	26	87,5	51	27,5			
M43340-20-20	31	- 20	1.1/4"	1.1/4"	26,1	100,5	51	29,5			
M43340-20-20038	31	- 20	1.1/4"	1.1/4"	26,1	109	50,9	38			
M43340-20-24	31	- 20	1.1/4"	1.1/2"	32,1	101,5	60,5	31			
M43340-24-24	38	- 24	1.1/2"	1.1/2"	32,1	111	60,5	34,5			
M43340-24-24044	38	- 24	1.1/2"	1.1/2"	32,1	120	60,5	44			
M43340-24-32	38	- 24	1.1/2"	2"	42	113	71,6	34,5			
M43340-32-32	51	- 32	2"	2"	42	128,5	71,6	39			
M43340-32-32056	51	- 32	2"	2"	42	146	71,6	56			
M43340-48-48	76	- 48	3"	3"	59	147,5	101,6	53			

All items are made from solid with the exception of M43340-48-48

## SAE STANDARD CONNECTIONS

### M43390

90° ISO/SAE CODE 61 FLANGE - SAE J516 / ISO 12151-3

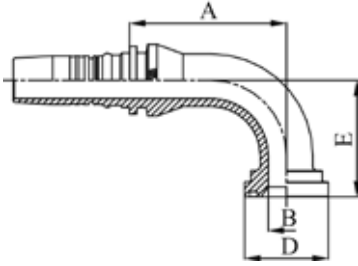

PART. REF.	HOSE BORE			Flange	DIMENSIONS mm						
	DN	Dash	inch		Inch	B	A	D	E		
M43390-10-16	16	- 10	5/8"	1"	20	71	44,6	52			
M43390-12-12	19	- 12	3/4"	3/4"	16	72	38	52			
M43390-12-12058	19	- 12	3/4"	3/4"	16	72	38	58			
M43390-12-16	19	- 12	3/4"	1"	20	72,5	44,6	52			
M43390-16-16	25	- 16	1"	1"	20	83,5	44,6	62			
M43390-16-16070	25	- 16	1"	1"	20	83,5	44,5	70			
M43390-16-20	25	- 16	1"	1.1/4"	26	83,5	51	62			
M43390-20-16	31	- 20	1.1/4"	1"	19,8	96,5	44,6	66			
M43390-20-20	31	- 20	1.1/4"	1.1/4"	26,1	99	51	70			
M43390-20-20090	31	- 20	1.1/4"	1.1/4"	26,1	99	50,9	90			
M43390-20-24	31	- 20	1.1/4"	1.1/2"	32,1	98,5	60,5	72			
M43390-24-24	38	- 24	1.1/2"	1.1/2"	32,1	111,5	60,5	84			
M43390-24-24104	38	- 24	1.1/2"	1.1/2"	32,1	111,5	60,5	104			
M43390-24-32	38	- 24	1.1/2"	2"	42	111,5	71,6	84			
M43390-32-32	51	- 32	2"	2"	42	133,5	71,6	99			
M43390-32-32138	51	- 32	2"	2"	42	133,5	71,5	138			
M43390-48-48	76	- 48	3"	3"	59	145	101,6	140			

All items are made from solid with the exception of M43390-48-48

FITTINGS  
F 3-14

## SAE STANDARD CONNECTIONS

### M43610

ISO/SAE CODE 62 FLANGE - SAE J516 / ISO 12151-3

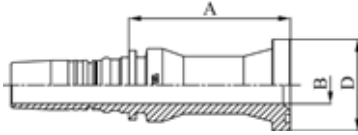

PART. REF.	HOSE BORE			Flange		DIMENSIONS mm						
	DN	Dash	inch	Inch		B	A	D				
M43610-10-12	16	- 10	5/8"	3/4"		16	65	41,5				
M43610-10-16	16	- 10	5/8"	1"		20	81,5	47,7				
M43610-12-12	19	- 12	3/4"	3/4"		16	71,5	41,4				
M43610-12-16	19	- 12	3/4"	1"		20	83,5	47,7				
M43610-16-12	25	- 16	1"	3/4"		16	80,5	41,4				
M43610-16-16	25	- 16	1"	1"		20	84,5	47,7				
M43610-16-20	25	- 16	1"	1.1/4"		26	89	54,2				
M43610-20-16	31	- 20	1.1/4"	1"		20	87	47,7				
M43610-20-20	31	- 20	1.1/4"	1.1/4"		26,1	91	54,2				
M43610-20-24	31	- 20	1.1/4"	1.1/2"		32,1	97	63,7				
M43610-24-20	38	- 24	1.1/2"	1.1/4"		26	101	54,2				
M43610-24-24	38	- 24	1.1/2"	1.1/2"		32,1	97,5	63,7				
M43610-24-32	38	- 24	1.1/2"	2"		42	113	79,6				
M43610-32-24	51	- 32	2"	1.1/2"		32,1	117	63,7				
M43610-32-32	51	- 32	2"	2"		42	112,5	79,6				
M43610-40-40	63	- 40	2.1/2"	2.1/2"		51,5	126,5	107,9				
M43610-48-48	76	- 48	3"	3"		62,5	167	131,9				

## SAE STANDARD CONNECTIONS

### M43630

30° ISO/SAE CODE 62 FLANGE - SAE J516 / ISO 12151-3

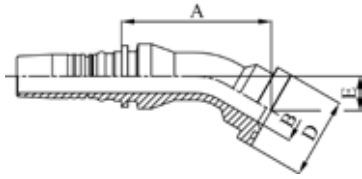

PART. REF.	HOSE BORE			Flange	DIMENSIONS mm							
	DN	Dash	inch		Inch	B	A	D	E			
M43630-12-12	19	- 12	3/4"	3/4"		16	87	41,4	17,5			
M43630-16-12	25	- 16	1"	3/4"		16	93	41,4	17			
M43630-16-16	25	- 16	1"	1"		20	98,5	47,7	20			
M43630-20-20	31	- 20	1.1/4"	1.1/4"		26,1	115,5	54,2	23			
M43630-24-24	38	- 24	1.1/2"	1.1/2"		32	133,5	63,7	27			
M43630-32-32	51	- 32	2"	2"		42	167	79,6	36,5			

## SAE STANDARD CONNECTIONS

### M43640

45° ISO/SAE CODE 62 FLANGE - SAE J516 / ISO 12151-3

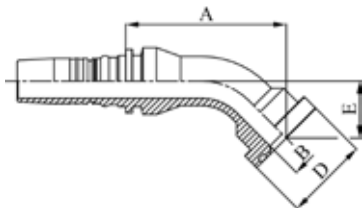

PART. REF.	HOSE BORE			Flange	DIMENSIONS mm							
	DN	Dash	inch		Inch	B	A	D	E			
M43640-10-12	16	- 10	5/8"	3/4"		16	71	41,4	31			
M43640-10-16	16	- 10	5/8"	1"		20	83,5	47,7	32,5			
M43640-12-12	19	- 12	3/4"	3/4"		16	79	41,4	26			
M43640-12-16	19	- 12	3/4"	1"		20	85,5	47,7	32,5			
M43640-16-12	25	- 16	1"	3/4"		16	87	41,4	28			
M43640-16-16	25	- 16	1"	1"		20	91,5	47,7	32,5			
M43640-16-20	25	- 16	1"	1.1/4"		26	93,5	54,2	37,5			
M43640-20-16	31	- 20	1.1/4"	1"		20	106,5	47,7	36			
M43640-20-20	31	- 20	1.1/4"	1.1/4"		26,1	108	54,2	37,5			
M43640-20-24	31	- 20	1.1/4"	1.1/2"		32,1	115	63,7	45			
M43640-24-20	38	- 24	1.1/2"	1.1/4"		26	124,5	54,2	43			
M43640-24-24	38	- 24	1.1/2"	1.1/2"		32	124,5	63,7	44			
M43640-24-32	38	- 24	1.1/2"	2"		42	135,5	79,6	55,5			
M43640-32-32	51	- 32	2"	2"		42	154	79,6	60,5			
M43640-32-32056	51	- 32	2"	2"		42	150	79,6	56,5			

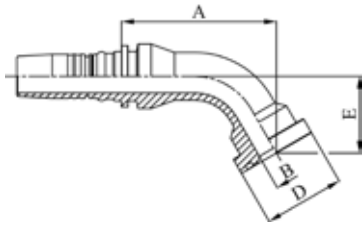

## SAE STANDARD CONNECTIONS

### M43660

60° ISO/SAE CODE 62 FLANGE - SAE J516 / ISO 12151-3

PART. REF.	HOSE BORE			Flange	DIMENSIONS mm						
	DN	Dash	inch		Inch	B	A	D	E		
M43660-12-12	19	- 12	3/4"	3/4"	16	98,5	41,4	39			
M43660-12-16	19	- 12	3/4"	1"	20	101	47,7	44			
M43660-16-16	25	- 16	1"	1"	20	107	47,7	52			
M43660-20-20	31	- 20	1.1/4"	1.1/4"	26,1	130	54,2	59			
M43660-20-24	31	- 20	1.1/4"	1.1/2"	32,1	136,5	63,7	66			
M43660-24-24	38	- 24	1.1/2"	1.1/2"	32	154	63,7	61,5			
M43660-32-32	51	- 32	2"	2"	42	197,5	79,6	85			

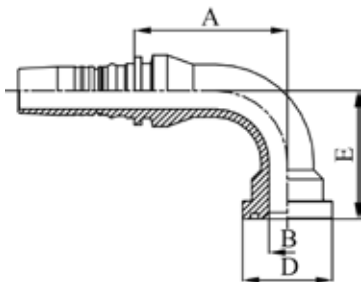

## SAE STANDARD CONNECTIONS

### M43690

90° ISO/SAE CODE 62 FLANGE - SAE J516 / ISO 12151-3

PART. REF.	HOSE BORE			Flange	DIMENSIONS mm						
	DN	Dash	inch		Inch	B	A	D	E		
M43690-10-12	16	- 10	5/8"	3/4"	16	56,5	41,4	60,5			
M43690-12-12	19	- 12	3/4"	3/4"	16	72,5	41,4	59			
M43690-12-16	19	- 12	3/4"	1"	20	72,5	47,7	65			
M43690-16-12	25	- 16	1"	3/4"	16	81,5	41,4	62			
M43690-16-16	25	- 16	1"	1"	20	81	47,7	68			
M43690-16-20	25	- 16	1"	1.1/4"	26	78,5	54,2	76			
M43690-20-16	31	- 20	1.1/4"	1"	20	98,5	47,7	79			
M43690-20-20	31	- 20	1.1/4"	1.1/4"	26,1	98,5	54,2	81			
M43690-20-20090	31	- 20	1.1/4"	1.1/4"	26,1	98,5	54,1	90			
M43690-20-24	31	- 20	1.1/4"	1.1/2"	32,1	98,5	63,7	91,5			
M43690-24-20	38	- 24	1.1/2"	1.1/4"	26	111	54,2	91			
M43690-24-24	38	- 24	1.1/2"	1.1/2"	32	112,5	63,7	94,5			
M43690-24-24104	38	- 24	1.1/2"	1.1/2"	32	112,5	63,7	104			
M43690-24-32	38	- 24	1.1/2"	2"	42	112,5	79,6	110,5			
M43690-32-32	51	- 32	2"	2"	42	140,5	79,6	132			
M43690-32-32138	51	- 32	2"	2"	42	140,5	79,6	138			

## DIN STANDARD CONNECTIONS

### M31210

METRIC MALE 24° CONE SEAT HEAVY DUTY - DIN 20066 / ISO 12151-2

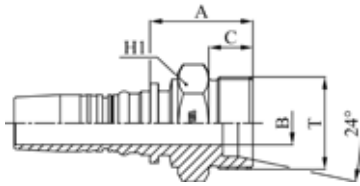

PART. REF.	HOSE BORE			Thread	Pipe	DIMENSIONS mm						
	DN	Dash	inch			T	mm	B	A	C	H1	
M31210-10-30	16	- 10	5/8"	M 30x2	20	12	37	16	30			
M31210-12-30	19	- 12	3/4"	M 30x2	20	14,5	38,5	16	32			
M31210-12-36	19	- 12	3/4"	M 36x2	25	14,5	43,5	18	36			
M31210-16-36	25	- 16	1"	M 36x2	25	19,5	45	18	36			
M31210-16-42	25	- 16	1"	M 42x2	30	19,5	47	20	46			
M31210-20-52	31	- 20	1.1/4"	M 52x2	38	25	55	22	55			
M31210-24-52	38	- 24	1.1/2"	M 52x2	38	31	55,5	22	55			

## DIN STANDARD CONNECTIONS

### M41612/M41613

METRIC O-RING FEMALE 24° CONE HEAVY DUTY - DIN 20066 / ISO 12151-2

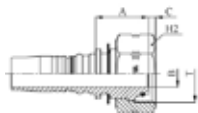
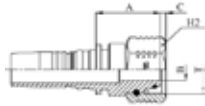

PART. REF.	HOSE BORE			Thread	Pipe	DIMENSIONS mm						
	DN	Dash	inch			T	mm	B	A	C	H2	
M41612-10-24	16	- 10	5/8"	M 24x1,5	16	9,3	31	4	30			
M41613-10-30	16	- 10	5/8"	M 30x2	20	12	37	3,5	36			
M41612-12-30	19	- 12	3/4"	M 30x2	20	12,5	44	3,2	36			
M41613-12-36	19	- 12	3/4"	M 36x2	25	14,5	42	3,4	41			
M41613-12-42	19	- 12	3/4"	M 42x2	30	19	36	6,3	50			
M41612-16-36	25	- 16	1"	M 36x2	25	16	47	4,1	41			
M41613-16-42	25	- 16	1"	M 42x2	30	19,5	46,5	5,3	50			
M41613-16-52	25	- 16	1"	M 52x2	38	26,1	49,5	8	60			
M41612-20-42	31	- 20	1.1/4"	M 42x2	30	19	47,5	6	50			
M41613-20-52	31	- 20	1.1/4"	M 52x2	38	26,1	41,5	8	60			
M41612-24-52	38	- 24	1.1/2"	M 52x2	38	29	52,5	8,8	60			

M41612: THRUST-WIRE NUT - M41613: SLIP-ON NUT

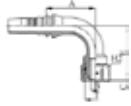

## DIN STANDARD CONNECTIONS

### M41692/M41693

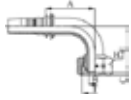

**90° METRIC O-RING FEMALE SWEPT ELBOW 24° CONE HEAVY DUTY**  
**DIN 20066 / ISO 12151-2**

PART. REF.	HOSE BORE			Thread	Pipe	DIMENSIONS mm						
	DN	Dash	inch			T	mm	B	A	C	E	H2
M41693-10-30	16	- 10	5/8"	M 30x2	20	12	52,5	3,5	57,5	36		
M41692-12-30	19	- 12	3/4"	M 30x2	25	12,5	64	3,2	68,5	36		
M41693-12-36	19	- 12	3/4"	M 36x2	25	14,5	67	3,4	67,5	41		
M41692-16-36	25	- 16	1"	M 36x2	25	16	81,5	4,1	89	41		
M41693-16-42	25	- 16	1"	M 42x2	30	19,5	81,5	5,3	75,5	50		
M41692-20-42	31	- 20	1.1/4"	M 42x2	30	19,1	103,5	6	90	50		
M41693-20-52	31	- 20	1.1/4"	M 52x2	38	26,1	100	8	86,5	60		

M41692: THRUST-WIRE NUT - M41693: SLIP-ON NUT

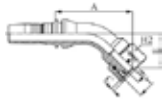

## DIN STANDARD CONNECTIONS

### M41642/M41643

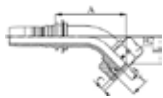

**45° METRIC O-RING FEMALE SWEPT ELBOW 24° CONE HEAVY DUTY**  
**DIN 20066 / ISO 12151-2**

PART. REF.	HOSE BORE			Thread	Pipe	DIMENSIONS mm						
	DN	Dash	inch			T	mm	B	A	C	E	H2
M41643-10-30	16	- 10	5/8"	M 30x2	20	12	66,5	3,5	29,5	36		
M41642-12-30	19	- 12	3/4"	M 30x2	20	12,5	79	3,2	35	36		
M41643-12-36	19	- 12	3/4"	M 36x2	25	14,5	81	3,4	33,5	41		
M41642-16-36	25	- 16	1"	M 36x2	25	16	103	4,1	45,5	41		
M41643-16-42	25	- 16	1"	M 42x2	30	19,5	93	5,3	36	50		
M41642-20-42	31	- 20	1.1/4"	M 42x2	30	19,1	116,5	6	44,5	50		
M41643-20-52	31	- 20	1.1/4"	M 52x2	38	26,1	110	8	40	60		
M41642-24-52	38	- 24	1.1/2"	M 52x2	38	29	128	8,8	51,5	60		

M41642: THRUST-WIRE NUT - M41643: SLIP-ON NUT

## DIN STANDARD CONNECTIONS

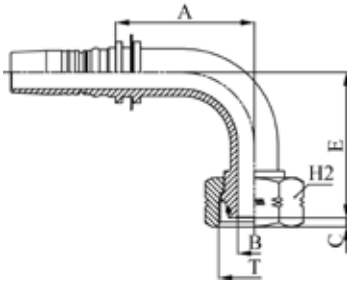

### M41293 LONG DROP

90° METRIC O-RING FEMALE MEDIUM/LONG DROP ELBOW 24°  
CONE HEAVY DUTY DIN 20066 / ISO 12151-2 (SLIP-ON NUT)

PART. REF.	HOSE BORE			Thread	Pipe	DIMENSIONS mm						
	DN	Dash	inch			T	mm	B	A	C	E	H2
M41293-10-30	16	- 10	5/8"	M 30x2	20	12	53	3,5	60	36		
M41293-12-36	19	- 12	3/4"	M 36x2	25	14,5	67	3,4	67,5	41		
M41293-16-42	25	- 16	1"	M 42x2	30	19,5	81,5	5,3	86	50		
M41293-20-52	31	- 20	1.1/4"	M 52x2	38	26,1	100	8	92	60		

## DIN STANDARD CONNECTIONS

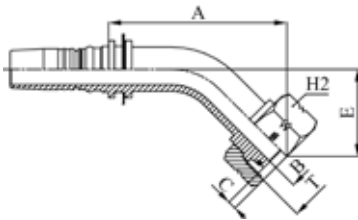

### M41243 LONG DROP

45° METRIC O-RING FEMALE MEDIUM/LONG DROP ELBOW 24°  
CONE HEAVY DUTY DIN 20066/ ISO 12151-2 (SLIP-ON NUT)

PART. REF.	HOSE BORE			Thread	Pipe	DIMENSIONS mm						
	DN	Dash	inch			T	mm	B	A	C	E	H2
M41243-10-30	16	- 10	5/8"	M 30x2	20	12	77,5	3,5	35	36		
M41243-12-36	19	- 12	3/4"	M 36x2	25	14,5	101	3,4	45	41		
M41243-16-42	25	- 16	1"	M 42x2	30	19,5	112	5,3	55	50		
M41243-20-52	31	- 20	1.1/4"	M 52x2	38	26,1	133	8	63	60		



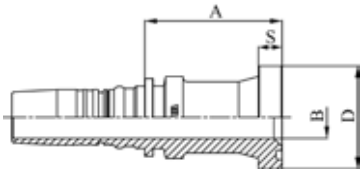

## ORIGINAL EQUIPMENT CONNECTIONS

### M43710

FLANGE PLUS (SAE J518 CODE 62 - ISO 6162-2 PORT COMPATIBLE)

PART. REF.	HOSE BORE			Flange	DIMENSIONS mm						
	DN	Dash	inch		Inch	B	A	D	S		
M43710-10-12	16	- 10	5/8"	3/4"	16	51,5	41,5	9			
M43710-12-12	19	- 12	3/4"	3/4"	14,5	71,5	41,4	10			
M43710-16-16	25	- 16	1"	1"	19,5	64	47,7	11			
M43710-20-20	31	- 20	1.1/4"	1.1/4"	25	81	54,2	12			

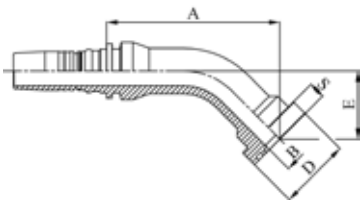

## ORIGINAL EQUIPMENT CONNECTIONS

### M43740

45° FLANGE PLUS (SAE J518 CODE 62 - ISO 6162-2 PORT COMPATIBLE)

PART. REF.	HOSE BORE			Flange	DIMENSIONS mm						
	DN	Dash	inch		Inch	B	A	D	E	S	
M43740-10-12	16	- 10	5/8"	3/4"	16	72,5	41,4	31	9		
M43740-12-12	19	- 12	3/4"	3/4"	14,5	113	41,4	40	10		
M43740-16-16	25	- 16	1"	1"	19,5	113,5	47,7	43	11		
M43740-20-20	31	- 20	1.1/4"	1.1/4"	25	133,5	54,2	50	12		

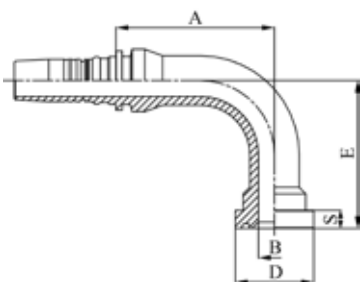

## ORIGINAL EQUIPMENT CONNECTIONS

### M43790

90° FLANGE PLUS (SAE J518 CODE 62 - ISO 6162-2 PORT COMPATIBLE)

PART. REF.	HOSE BORE			Flange	DIMENSIONS mm						
	DN	Dash	inch		Inch	B	A	D	E	S	
M43790-10-12	16	- 10	5/8"	3/4"	16	61,5	41,4	60,5	9		
M43790-12-12	19	- 12	3/4"	3/4"	14,5	93	41,4	75	10		
M43790-16-16	25	- 16	1"	1"	19,5	90	47,7	90	11		
M43790-20-20	31	- 20	1.1/4"	1.1/4"	25	115	54,2	110	12		

## ORIGINAL EQUIPMENT CONNECTIONS

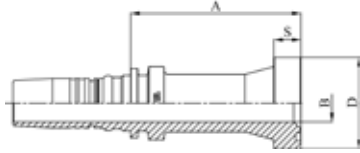

### M43910

#### STRAIGHT SUPERCAT SERIES FLANGE

PART. REF.	HOSE BORE			Flange	DIMENSIONS mm							
	DN	Dash	inch		Inch	B	A	D	S			
M43910-12-12	19	- 12	3/4"	3/4"		16	77	41,5	14,3			
M43910-12-16	19	- 12	3/4"	1"		20	88,5	47,7	14,3			
M43910-16-16	25	- 16	1"	1"		20	89,5	47,7	14,3			
M43910-16-20	25	- 16	1"	1.1/4"		26	93,5	54	14,3			
M43910-20-20	31	- 20	1.1/4"	1.1/4"		26,1	95	54	14,3			
M43910-20-24	31	- 20	1.1/4"	1.1/2"		32,1	98,5	63,6	14,3			
M43910-24-24	38	- 24	1.1/2"	1.1/2"		32,1	99	63,6	14,3			
M43910-24-32	38	- 24	1.1/2"	2"		42	115	79,3	14,3			
M43910-32-24	51	- 32	2"	1.1/2"		32,1	119,5	63,6	14,3			
M43910-32-32	51	- 32	2"	2"		42	114,5	79,3	14,3			

## ORIGINAL EQUIPMENT CONNECTIONS

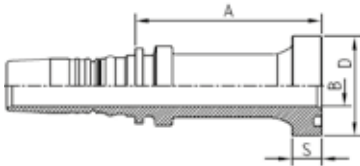

### M43910CT

#### STRAIGHT REALCAT FLANGE

PART. REF.	HOSE BORE			Flange	DIMENSIONS mm							
	DN	Dash	inch		Inch	B	A	D	S			
M43910-16-16CT	25	- 16	1"	1"		19,5	89,5	47,7	14,3			
M43910-20-20CT	31	- 20	1.1/4"	1.1/4"		25	95	54	14,3			
M43910-20-24CT	31	- 20	1.1/4"	1.1/2"		31	98	63,6	14,3			
M43910-24-24CT	38	- 24	1.1/2"	1.1/2"		31	99	63,6	14,3			

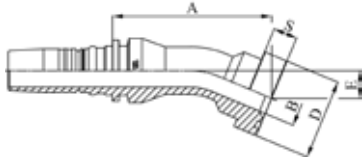

## ORIGINAL EQUIPMENT CONNECTIONS

### M43920

#### 22,5° SUPERCAT SERIES FLANGE

PART. REF.	HOSE BORE			Flange		DIMENSIONS mm						
	DN	Dash	inch			Inch	B	A	D	E		
M43920-12-12	19	- 12	3/4"	3/4"		16	94	41,5	14,5	14,3		
M43920-12-16	19	- 12	3/4"	1"		20	101,5	47,7	16,5	14,3		
M43920-16-16	25	- 16	1"	1"		20	110,5	47,7	16,5	14,3		
M43920-16-20	25	- 16	1"	1.1/4"		26,1	115,5	54	19	14,3		
M43920-20-20	31	- 20	1.1/4"	1.1/4"		26,1	122	54	18	14,3		
M43920-20-24	31	- 20	1.1/4"	1.1/2"		32	139	63,7	23	14,3		
M43920-24-24	38	- 24	1.1/2"	1.1/2"		32	138	63,7	20	14,3		

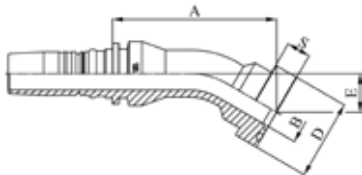

## ORIGINAL EQUIPMENT CONNECTIONS

### M43930

#### 30° SUPERCAT SERIES FLANGE

PART. REF.	HOSE BORE			Flange		DIMENSIONS mm						
	DN	Dash	inch			Inch	B	A	D	E		
M43930-12-12	19	- 12	3/4"	3/4"		16	92	41,5	20	14,3		
M43930-12-16	19	- 12	3/4"	1"		20	99	47,7	22,5	14,3		
M43930-16-16	25	- 16	1"	1"		20	108	47,7	23	14,3		
M43930-16-20	25	- 16	1"	1.1/4"		26,1	112,5	54	26	14,3		
M43930-20-20	31	- 20	1.1/4"	1.1/4"		26,1	119,5	54	25	14,3		
M43930-20-24	31	- 20	1.1/4"	1.1/2"		32	135,5	63,7	32	14,3		
M43930-24-24	38	- 24	1.1/2"	1.1/2"		32	135	63,7	28	14,3		
M43930-24-32	38	- 24	1.1/2"	2"		42	151,5	79,3	36	14,3		
M43930-32-32	51	- 32	2"	2"		42	171,5	79,3	37,5	14,3		

## ORIGINAL EQUIPMENT CONNECTIONS

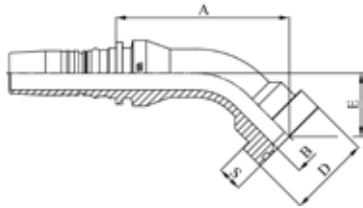

### M43940

#### 45° SUPERCAT SERIES FLANGE

PART. REF.	HOSE BORE			Flange	DIMENSIONS mm						
	DN	Dash	inch		Inch	B	A	D	E	S	
M43940-12-12	19	- 12	3/4"	3/4"	16	85	41,5	32	14,3		
M43940-12-16	19	- 12	3/4"	1"	20	91,5	47,7	35,5	14,3		
M43940-16-16	25	- 16	1"	1"	20	100,5	47,7	36,5	14,3		
M43940-16-20	25	- 16	1"	1.1/4"	26,1	103,5	54	40,5	14,3		
M43940-20-20	31	- 20	1.1/4"	1.1/4"	26,1	110,5	54	40,5	14,3		
M43940-20-24	31	- 20	1.1/4"	1.1/2"	32	124,5	63,7	50,5	14,3		
M43940-24-24	38	- 24	1.1/2"	1.1/2"	32	125,5	63,7	45,5	14,3		
M43940-24-32	38	- 24	1.1/2"	2"	42	139,5	79,3	56,5	14,3		
M43940-32-32	51	- 32	2"	2"	42	158,5	79,3	61,5	14,3		

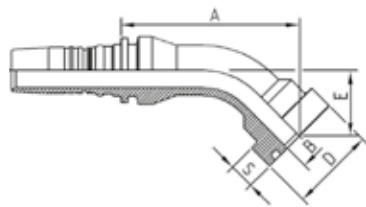

## ORIGINAL EQUIPMENT CONNECTIONS

### M43940CT

#### 45° REALCAT FLANGE

PART. REF.	HOSE BORE			Flange	DIMENSIONS mm						
	DN	Dash	inch		Inch	B	A	D	E	S	
M43940-16-16CT	25	- 16	1"	1"	19,5	100,5	47,7	36,5	14,3		
M43940-16-20CT	25	- 16	1"	1.1/4"	25	103,5	54	40,5	14,3		
M43940-20-20CT	31	- 20	1.1/4"	1.1/4"	25	110,5	54	40,5	14,3		
M43940-20-24CT	31	- 20	1.1/4"	1.1/2"	31	124,5	63,7	50,5	14,3		
M43940-24-24CT	38	- 24	1.1/2"	1.1/2"	31	125,5	63,7	45	14,3		

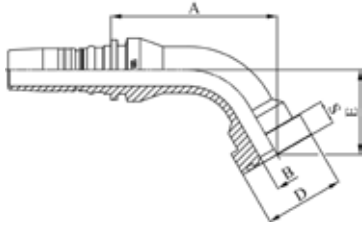

## ORIGINAL EQUIPMENT CONNECTIONS

### M43960

#### 60° SUPERCAT SERIES FLANGE

PART. REF.	HOSE BORE			Flange	DIMENSIONS mm							
	DN	Dash	inch		Inch	B	A	D	E	S		
M43960-12-12	19	- 12	3/4"	3/4"		16	101	41,5	44	14,3		
M43960-12-16	19	- 12	3/4"	1"		20	106	47,7	48	14,3		
M43960-16-16	25	- 16	1"	1"		20	122	47,7	51	14,3		
M43960-16-16055	25	- 16	1"	1"		20	102,5	47,7	55	14,3		
M43960-16-20	25	- 16	1"	1.1/4"		26,1	122	54	55	14,3		
M43960-20-20	31	- 20	1.1/4"	1.1/4"		26,1	136	54	56	14,3		
M43960-20-24	31	- 20	1.1/4"	1.1/2"		32	149	63,7	69	14,3		
M43960-24-24	38	- 24	1.1/2"	1.1/2"		32	154,5	63,7	63	14,3		
M43960-32-32	51	- 32	2"	2"		42	202	79,3	86,5	14,3		
M43960-32-32150	51	- 32	2"	2"		42	196,5	79,3	150	14,3		

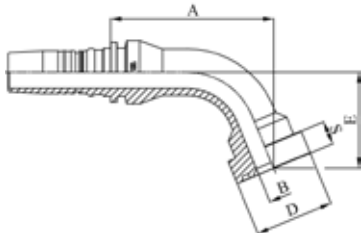

## ORIGINAL EQUIPMENT CONNECTIONS

### M43970

#### 67,5° SUPERCAT SERIES FLANGE

PART. REF.	HOSE BORE			Flange	DIMENSIONS mm							
	DN	Dash	inch		Inch	B	A	D	E	S		
M43970-12-12	19	- 12	3/4"	3/4"		16	95	41,5	49,5	14,3		
M43970-12-16	19	- 12	3/4"	1"		20	99,5	47,7	54	14,3		
M43970-16-16	25	- 16	1"	1"		20	115	47,7	58	14,3		
M43970-16-20	25	- 16	1"	1.1/4"		26,1	114,5	54	62	14,3		
M43970-20-20	31	- 20	1.1/4"	1.1/4"		26,1	128	54	64	14,3		
M43970-20-24	31	- 20	1.1/4"	1.1/2"		32	139,5	63,7	78	14,3		
M43970-24-24	38	- 24	1.1/2"	1.1/2"		32	146	63,7	72	14,3		
M43970-32-32	51	- 32	2"	2"		42	189,5	79,3	99	14,3		

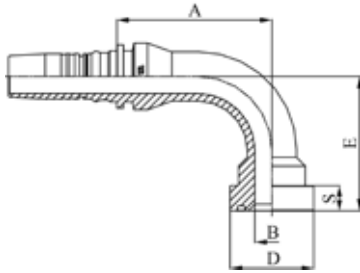

## ORIGINAL EQUIPMENT CONNECTIONS

### M43990

#### 90° SUPERCAT SERIES FLANGE

PART. REF.	HOSE BORE			Flange	DIMENSIONS mm						
	DN	Dash	inch		Inch	B	A	D	E	S	
M43990-12-12	19	- 12	3/4"	3/4"	16	72,5	41,5	64,5	14,3		
M43990-12-16	19	- 12	3/4"	1"	20	75	47,7	69,5	14,3		
M43990-16-16	25	- 16	1"	1"	20	88,5	47,7	76,5	14,3		
M43990-16-20	25	- 16	1"	1.1/4"	26,1	86,5	54	80,5	14,3		
M43990-20-20	31	- 20	1.1/4"	1.1/4"	26,1	98,5	54	85	14,3		
M43990-20-24	31	- 20	1.1/4"	1.1/2"	32	104	63,7	101	14,3		
M43990-24-24	38	- 24	1.1/2"	1.1/2"	32	112,5	63,7	96	14,3		
M43990-24-32	38	- 24	1.1/2"	2"	42	115	79,3	112	14,3		
M43990-32-32	51	- 32	2"	2"	42	144	79,3	133,5	14,3		

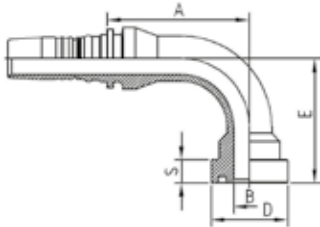

## ORIGINAL EQUIPMENT CONNECTIONS

### M43990CT

#### 90° REALCAT FLANGE

PART. REF.	HOSE BORE			Flange	DIMENSIONS mm						
	DN	Dash	inch		Inch	B	A	D	E	S	
M43990-16-16CT	25	- 16	1"	1"	19,5	88,5	47,7	76,5	14,3		
M43990-16-20CT	25	- 16	1"	1.1/4"	25	86,5	54	80,5	14,3		
M43990-20-20CT	31	- 20	1.1/4"	1.1/4"	25	98,5	54	85	14,3		
M43990-24-24CT	38	- 24	1.1/2"	1.1/2"	31	112,5	63,7	96	14,3		

## ORIGINAL EQUIPMENT CONNECTIONS

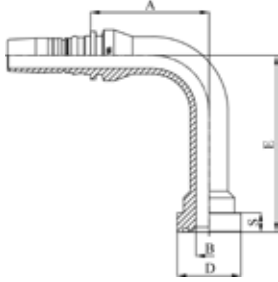

### M43990 LONG DROP

#### 90° LONG DROP SUPERCAT SERIES FLANGE

PART. REF.	HOSE BORE			Flange	DIMENSIONS mm						
	DN	Dash	inch		Inch	B	A	D	E	S	
M43990-16-16132	25	- 16	1"	1"	20	88,5	47,7	132	14,3		
M43990-16-16150	25	- 16	1"	1"	20	88,5	47,7	150	14,3		
M43990-16-20150	25	- 16	1"	1.1/4"	26,1	88,5	54	150	14,3		
M43990-20-20092	31	- 20	1.1/4"	1.1/4"	26,1	98,5	54	92	14,3		
M43990-20-20150	31	- 20	1.1/4"	1.1/4"	26,1	98,5	54	150	14,3		
M43990-20-24135	31	- 20	1.1/4"	1.1/2"	32	98,5	63,7	135	14,3		
M43990-24-24106	38	- 24	1.1/2"	1.1/2"	32	112,5	63,7	106	14,3		

## XTRAF LANGE

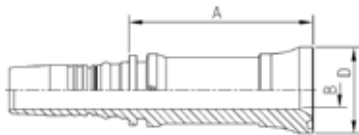

### M48410

#### XTRAF LANGE/61 (ISO6162-1/SAE J518 CODE 61 PORT COMPATIBLE)

PART. REF.	HOSE BORE			Flange	DIMENSIONS mm						
	DN	Dash	inch		Inch	B	A	D			
M48410-16-16	25	- 16	1"	1"	19,5	94,5	44,5				
M48410-20-20	31	- 20	1.1/4"	1.1/4"	25	103,5	50,5				
M48410-24-24	38	- 24	1.1/2"	1.1/2"	31	116	60,5				
M48410-32-32	51	- 32	2"	2"	41	101	71,6				
M48410-40-40	63	- 40	2.1/2"	2.1/2"	51,5	103	84,4				

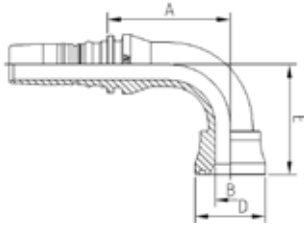

## XTRAFLLANGE

### M48490

90° XTRAFLLANGE/61 (ISO6162-1/SAE J518 CODE 61 PORT COMPATIBLE)

PART. REF.	HOSE BORE			Flange	DIMENSIONS mm							
	DN	Dash	inch		Inch	B	A	D	E			
M48490-16-16	25	- 16	1"	1"	19,5	77,5	44,5	69,5				
M48490-20-20	31	- 20	1.1/4"	1.1/4"	25	107	50,5	90				
M48490-24-24	38	- 24	1.1/2"	1.1/2"	31	112	60,5	104				
M48490-32-32	51	- 32	2"	2"	41	145	71,6	138				

## XTRAFLLANGE

### M48510

XTRAFLLANGE/62 (SAE J518 CODE 62 - ISO 6162-2 PORT COMPATIBLE)

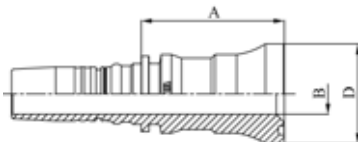

PART. REF.	HOSE BORE			Flange	DIMENSIONS mm							
	DN	Dash	inch		Inch	B	A	D				
M48510-12-12	19	- 12	3/4"	3/4"	14,5	64	41,4					
M48510-16-16	25	- 16	1"	1"	19,5	68,5	47,7					
M48510-20-20	31	- 20	1.1/4"	1.1/4"	25	88	54,4					
M48510-24-24	38	- 24	1.1/2"	1.1/2"	31	102	63,7					
M48510-32-32	51	- 32	2"	2"	41	128,5	79,6					
M48510-40-40	63	- 40	2.1/2"	2.1/2"	51,5	148,5	99,2					



## XTRAFLANGE

### M48540

45° XTRAFLANGE/62 (SAE J518 CODE 62 - ISO 6162-2 PORT COMPATIBLE)

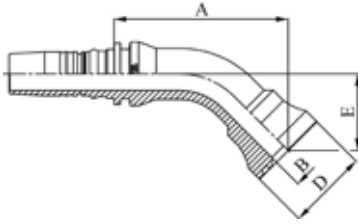

PART. REF.	HOSE BORE			Flange		DIMENSIONS mm						
	DN	Dash	inch			Inch	B	A	D			
M48540-12-12	19	- 12	3/4"	3/4"		14,5	92,5	41,4	38			
M48540-16-16	25	- 16	1"	1"		19,5	101,5	47,7	45			
M48540-20-20	31	- 20	1.1/4"	1.1/4"		25	138	54,4	62,5			
M48540-24-24	38	- 24	1.1/2"	1.1/2"		31	155	63,7	71,5			
M48540-32-32	51	- 32	2"	2"		39	193,5	79,6	92,5			

## XTRAFLANGE

### M48590

90° XTRAFLANGE/62 (SAE J518 CODE 62 - ISO 6162-2 PORT COMPATIBLE)

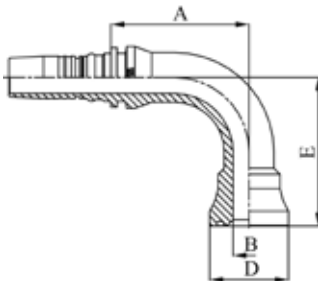

PART. REF.	HOSE BORE			Flange		DIMENSIONS mm						
	DN	Dash	inch			Inch	B	A	D			
M48590-12-12	19	- 12	3/4"	3/4"		14,5	75,5	41,4	75			
M48590-16-16	25	- 16	1"	1"		19,5	83,5	47,7	90			
M48590-20-20	31	- 20	1.1/4"	1.1/4"		25	107	54,4	120			
M48590-24-24	38	- 24	1.1/2"	1.1/2"		31	122	63,7	140			
M48590-32-32	51	- 32	2"	2"		39	147,5	79,6	178			

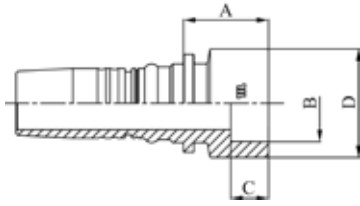

TAIL

**M49510WL**

WELDING TAIL

PART. REF.	HOSE BORE			DIMENSIONS mm								
	DN	Dash	inch			B	A	C	D			
M49510-10-18WL	16	- 10	5/8"			18,1	20,5	10	26			
M49510-12-22WL	19	- 12	3/4"			22,1	27,5	12	34			
M49510-16-28WL	25	- 16	1"			28,1	31,5	14	40			
M49510-20-35WL	31	- 20	1.1/4"			35,1	33	14	49			

FITTINGS  
F 3-30

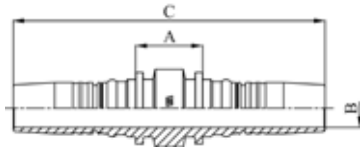

DOUBLE CONNECTOR

**M30050**

DOUBLE CONNECTOR

PART. REF.	HOSE BORE			DIMENSIONS mm								
	DN	Dash	inch			B	A	C				
M30050-20-20	31	- 20	1.1/4"			25	42	206				
M30050-24-24	38	- 24	1.1/2"			31	43,1	229,1				
M30050-32-32	51	- 32	2"			41	43	244,7				

O-RING

**JO29**

OPTIONAL INTERLOCK PLUS O-RING

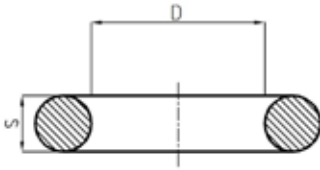

PART. REF.	HOSE BORE			DIMENSIONS mm								
	DN	Dash	inch			D	S					
JO29161218	16	- 10	5/8"			12,4	1,8					
JO29191618	19	- 12	3/4"			15,6	1,8					
JO29262218	25	- 16	1"			22	1,8					
JO29322818	31	- 20	1.1/4"			28,3	1,8					
JO29383518	38	- 24	1.1/2"			34,6	1,8					
JO29514718	51	- 32	2"			47,4	1,8					
JO29605718	63	- 40	2.1/2"			57,9	1,8					
JO29737018	76	- 48	3"			69,6	1,8					





# INTERLOCK PLUS STAINLESS STEEL



FITTING CODE	SECTION	PAGE
IM01500	3	33
IM01600	3	33
IM01800/IM01810	3	34
IM30510	3	34
IM31210	3	44
IM32510	3	36
IM32810	3	40
IM40812	3	35
IM40842	3	35
IM40892	3	3
IM41613	3	44
IM41643	3	45
IM41692/IM41693	3	45
IM42412	3	38
IM42442	3	39
IM42492	3	39
IM42512	3	37
IM42542	3	37
IM42592	3	38
IM43310	3	40
IM43340	3	41
IM43390	3	41
IM43610	3	42
IM43640	3	43
IM43690	3	43
IM43910	3	46
IM43940	3	46
IM43990	3	47

## INTERLOCK PLUS STAINLESS STEEL

DN	5	6	8	10	12	16	19	25	31	38	51	60	63	76	89	102
Inch	3/16"	1/4"	5/16"	3/8"	1/2"	5/8"	3/4"	1"	1 1/4"	1 1/2"	2"	2 3/8"	2 1/2"	3"	3 1/2"	4"
Size	-03	-04	-05	-06	-08	-10	-12	-16	-20	-24	-32	-38	-40	-48	-56	-64

### FERRULES

IM01500																	
IM01600																	
IM01800 / IM01810																	

### FITTINGS

BSP																	
SAE (JIC)																	
SAE (ORFS)																	
SAE (NPTF)																	
SAE FLANGE CODE 61																	
SAE FLANGE CODE 62																	
DIN METRIC 24° CONE HEAVY TYPE																	
ORIGINAL EQUIPMENT CONNECTIONS																	

FITTINGS F 3-W



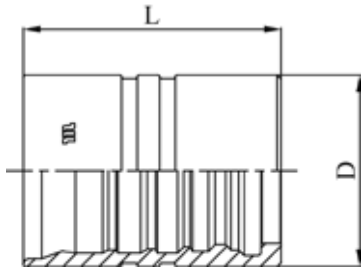

FERRULE

## IM01500

**DOUBLE SKIVE FERRULE FOR HEAVY DUTY SPIRAL HOSES (4 PLY)  
STAINLESS STEEL**

PART. REF.	HOSE BORE			DIMENSIONS mm							
	DN	Dash	inch			D	L				
IM01500-10	16	- 10	5/8"			35	40,9				
IM01500-12	19	- 12	3/4"			40	51,4				
IM01500-16	25	- 16	1"			48	64,5				
IM01500-20	31	- 20	1.1/4"			57	84				
IM01500-24	38	- 24	1.1/2"			64,3	94				
IM01500-32	51	- 32	2"			83,5	107				
IM01500-40	63	- 40	2.1/2"			100	135				
IM01500-48	76	- 48	3"			107	125				

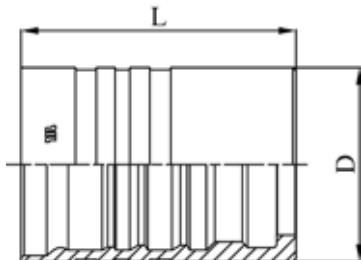

FERRULE

## IM01600

**DOUBLE SKIVE FERRULE FOR HEAVY DUTY SPIRAL HOSES (6 PLY)  
STAINLESS STEEL**

PART. REF.	HOSE BORE			DIMENSIONS mm							
	DN	Dash	inch			D	L				
IM01600-20	31	- 20	1.1/4"			60	85				
IM01600-24	38	- 24	1.1/2"			69	96				

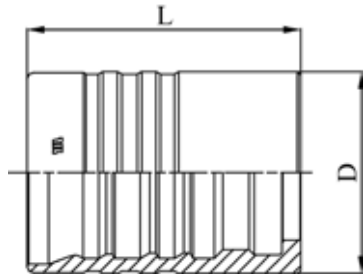

FERRULE

## IM01800/IM01810

DOUBLE SKIVE FERRULE FOR EXTRA DUTY SPIRAL HOSES (6 PLY)  
STAINLESS STEEL

PART. REF.	HOSE BORE			DIMENSIONS mm							
	DN	Dash	inch			D	L				
IM01800-20	31	- 20	1.1/4"			64,5	88,2				
IM01800-32	51	- 32	2"			86,5	108				
IM01810-40	63	- 40	2.1/2"			103	135				
IM01810-48	76	- 48	3"			113,5	125				

FITTINGS  
F 3-34

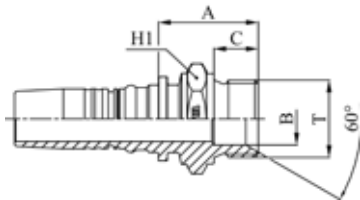

BS STANDARD CONNECTIONS

## IM30510

BSP MALE PARALLEL 60° CONE SEAT - BS5200 / ISO 8434-6  
(STAINLESS STEEL)

PART. REF.	HOSE BORE			Thread	DIMENSIONS mm							
	DN	Dash	inch		T	B	A	C	H1			
IM30510-12-12	19	- 12	3/4"	3/4" - 14		17	37	16	32			
IM30510-16-16	25	- 16	1"	1" - 11		22,5	43	19	41			
IM30510-20-20	31	- 20	1.1/4"	1.1/4" - 11		28,5	50,5	20	50			
IM30510-24-24	38	- 24	1.1/2"	1.1/2" - 11		33,5	54,5	22	55			
IM30510-32-32	51	- 32	2"	2" - 11		42	58	25	70			

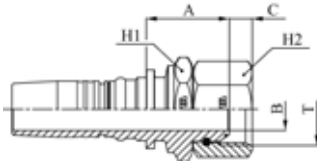

## BS STANDARD CONNECTIONS

### IM40812

**BSP O-RING FEMALE 60° CONE - BS5200 / ISO 12151-6 (THRUST-WIRE NUT) STAINLESS STEEL**

PART. REF.	HOSE BORE			Thread	DIMENSIONS mm						
	DN	Dash	inch		T	B	A	C	H1	H2	
IM40812-12-12	19	- 12	3/4"	3/4" - 14	14,5	39	8,5	32	32		
IM40812-16-16	25	- 16	1"	1" - 11	19,5	44,5	10,6	41	41		
IM40812-20-20	31	- 20	1.1/4"	1.1/4" - 11	26,1	52,5	10,5	50	50		
IM40812-24-24	38	- 24	1.1/2"	1.1/2" - 11	32,1	51,5	12,5	60	60		
IM40812-32-32	38	- 24	1.1/2"	1.1/2" - 11	42	51,5	16,1	70	70		

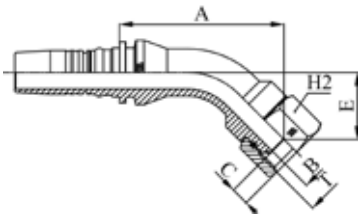

## BS STANDARD CONNECTIONS

### IM40842

**45° BSP O-RING FEMALE SWEPT ELBOW 60° CONE BS5200 / ISO 12151-6 (THRUST-WIRE NUT) STAINLESS STEEL**

PART. REF.	HOSE BORE			Thread	DIMENSIONS mm					
	DN	Dash	inch		T	B	A	C	E	H2
IM40842-12-12	19	- 12	3/4"	3/4" - 14	14,5	88	8,5	35	32	
IM40842-16-16	25	- 16	1"	1" - 11	19,5	97	10,6	40	41	
IM40842-20-20	31	- 20	1.1/4"	1.1/4" - 11	26,1	120	10,5	49,5	50	
IM40842-24-24	38	- 24	1.1/2"	1.1/2" - 11	32,1	126,5	12,5	50	60	
IM40842-32-32	51	- 32	2"	2" - 11,5	42	162,5	16,1	66,5	70	

## BS STANDARD CONNECTIONS

### IM40892

90° BSP O-RING FEMALE SWEPT ELBOW 60° CONE BS5200 / ISO 12151-6 (THRUST-WIRE NUT) STAINLESS STEEL

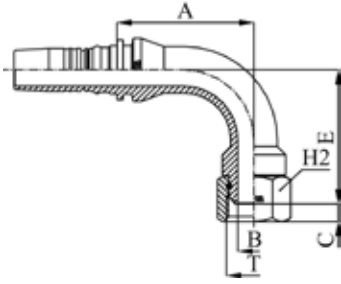

PART. REF.	HOSE BORE			Thread		DIMENSIONS mm						
	DN	Dash	inch			T	B	A	C	E	H2	
IM40892-12-12	19	- 12	3/4"	3/4" - 14		14,5	72,5	8,5	70	32		
IM40892-16-16	25	- 16	1"	1" - 11		19,5	82	10,6	80,5	41		
IM40892-20-20	31	- 20	1.1/4"	1.1/4" - 11		26,1	98,5	10,5	98	50		
IM40892-24-24	38	- 24	1.1/2"	1.1/2" - 11		32,1	111,5	12,5	109	60		
IM40892-32-32	51	- 32	2"	2" - 11,5		42	143	16,1	140,5	70		

## SAE STANDARD CONNECTIONS

### IM32510

JIC MALE 37° CONE - SAE J516 / ISO 12151-5 STAINLESS STEEL

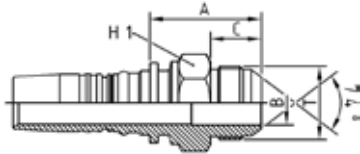

PART. REF.	HOSE BORE			Thread		DIMENSIONS mm					
	DN	Dash	inch			T	B	A	C	H1	
IM32510-10-10	16	- 10	5/8"	7/8" - 14		12	41	19,5	27		
IM32510-12-12	19	- 12	3/4"	1.1/16" - 12		15	45,5	22	32		
IM32510-16-16	25	- 16	1"	1.5/16" - 12		20	50,5	23	38		
IM32510-20-20	31	- 20	1.1/4"	1.5/8" - 12		26,1	66	24,3	46		
IM32510-24-24	38	- 24	1.1/2"	1.7/8" - 12		32,1	64	27,5	50		
IM32510-32-32	51	- 32	2"	2.1/2" - 12		42	81	34	70		

## SAE STANDARD CONNECTIONS

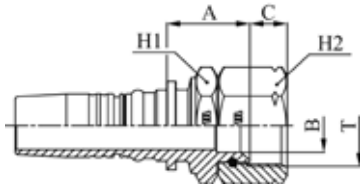

### IM42512

**JIC FEMALE 37° CONE SEAT - SAE J516 / ISO 12151-5 (THRUST-WIRE NUT) STAINLESS STEEL**

PART. REF.	HOSE BORE			Thread		DIMENSIONS mm						
	DN	Dash	inch			T	B	A	C	H1	H2	
IM42512-12-12	19	- 12	3/4"	1.1/16" - 12		15	36	16	32	32		
IM42512-16-16	25	- 16	1"	1.5/16" - 12		21,7	40,5	15,2	41	41		
IM42512-20-20	31	- 20	1.1/4"	1.5/8" - 12		26,1	51,5	16,2	50	50		
IM42512-24-24	38	- 24	1.1/2"	1.7/8" - 12		31	54,5	18,8	55	60		
IM42512-32-32	51	- 32	2"	2.1/2" - 8		42	54	24	70	75		

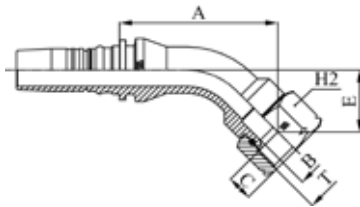

## SAE STANDARD CONNECTIONS

### IM42542

**45° JIC FEMALE SWEEP ELBOW 37° CONE SEAT - SAE J516 / ISO 12151-5 (THRUST-WIRE NUT) STAINLESS STEEL**

PART. REF.	HOSE BORE			Thread		DIMENSIONS mm						
	DN	Dash	inch			T	B	A	C	E	H2	
IM42542-12-12	19	- 12	3/4"	1.1/16" - 12		15	86	16	33	32		
IM42542-16-16	25	- 16	1"	1.5/16" - 12		21,7	95	15,2	37	41		
IM42542-20-20	31	- 20	1.1/4"	1.5/8" - 12		26,1	115,5	16,2	45	50		
IM42542-24-24	38	- 24	1.1/2"	1.7/8" - 12		32,1	126,5	18,8	50	60		

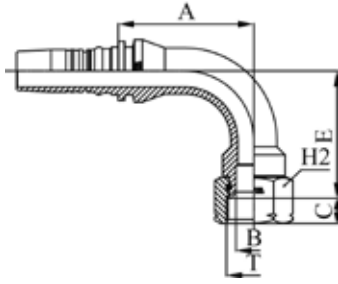

## SAE STANDARD CONNECTIONS

### IM42592

90° JIC FEMALE SWEEP ELBOW 37° CONE SEAT - SAE J516 / ISO 12151-5 (THRUST-WIRE NUT) STAINLESS STEEL

PART. REF.	HOSE BORE			Thread		DIMENSIONS mm						
	DN	Dash	inch			T	B	A	C	E	H2	
IM42592-12-12	19	- 12	3/4"	1.1/16" - 12		15	72,5	16	66	32		
IM42592-12-16	19	- 12	3/4"	1.5/16" - 12		21,7	72,5	15,2	71,5	41		
IM42592-16-16	25	- 16	1"	1.5/16" - 12		21,7	82,5	15,2	77,5	41		
IM42592-20-20	31	- 20	1.1/4"	1.5/8" - 12		26,1	98,5	16,2	92	50		
IM42592-24-24	38	- 24	1.1/2"	1.7/8" - 12		32,1	111,5	18,8	106	60		
IM42592-32-32	51	- 32	2"	2.1/2" - 8		42	144,5	24	137	75		

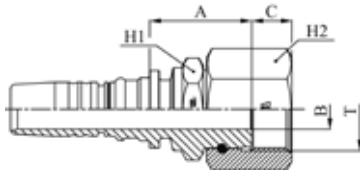

## SAE STANDARD CONNECTIONS

### IM42412

ORFS FEMALE - SAE J516 / ISO 12151-1 HEAVY TYPE (THRUST-WIRE NUT)

PART. REF.	HOSE BORE			Thread		DIMENSIONS mm						
	DN	Dash	inch			T	B	A	C	H1	H2	
IM42412-12-12	19	- 12	3/4"	1.3/16" - 12		14,5	37		32	36		
IM42412-16-16	25	- 16	1"	1.7/16" - 12		19,5	42	15	41	46		
IM42412-20-20	31	- 20	1.1/4"	1.11/16" - 12		25	52	15,1	50	55		
IM42412-24-24	38	- 24	1.1/2"	2" - 12		31	55	15	60	60		

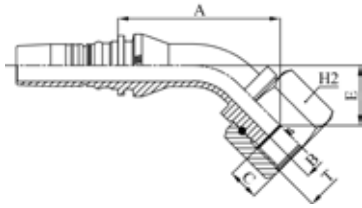

## SAE STANDARD CONNECTIONS

### IM42442

**45° ORFS FEMALE SWEPT ELBOW - SAE J516 / ISO 12151-1 HEAVY TYPE (THRUST-WIRE-NUT) STAINLESS STEEL**

PART. REF.	HOSE BORE			Thread	DIMENSIONS mm						
	DN	Dash	inch		T	B	A	C	E	H2	
IM42442-12-12	19	- 12	3/4"	1.3/16" - 12	14,5	89	13,9	36	36		
IM42442-16-16	25	- 16	1"	1.7/16" - 12	19,5	100	15	42,5	46		
IM42442-20-20	31	- 20	1.1/4"	1.11/16" - 12	25	119,5	15,1	49,5	55		
IM42442-24-24	38	- 24	1.1/2"	2" - 12	31	128,5	15	52	60		

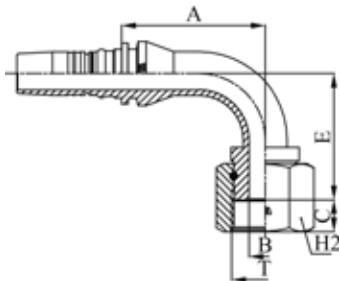

## SAE STANDARD CONNECTIONS

### IM42492

**90° ORFS FEMALE SWEPT ELBOW - SAE J516 / ISO 12151-1 HEAVY TYPE (THRUST-WIRE-NUT) STAINLESS STEEL**

PART. REF.	HOSE BORE			Thread	DIMENSIONS mm						
	DN	Dash	inch		T	B	A	C	E	H2	
IM42492-12-12	19	- 12	3/4"	1.3/16" - 12	14,5	72,5	13,9	70,5	36		
IM42492-16-16	25	- 16	1"	1.7/16" - 12	19,5	82,5	15	84,5	46		
IM42492-20-20	31	- 20	1.1/4"	1.11/16" - 12	25	98,5	15,1	98	55		
IM42492-24-24	38	- 24	1.1/2"	2" - 12	31	111,5	15	109	60		

## SAE STANDARD CONNECTIONS

### IM32810

NPTF MALE 60° CONE SEAT - SAE J516/J514 (STAINLESS STEEL)

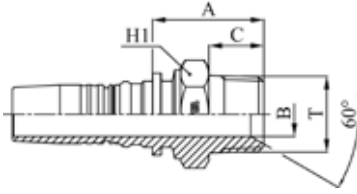

PART. REF.	HOSE BORE			Thread		DIMENSIONS mm						
	DN	Dash	inch			T	B	A	C			
IM32810-10-08	16	- 10	5/8"	1/2" - 14		12	39,5	19,2	24			
IM32810-10-12	16	- 10	5/8"	3/4" - 14		16	40,5	19,2	27			
IM32810-12-12	19	- 12	3/4"	3/4" - 14		16	43	19,2	32			
IM32810-16-16	25	- 16	1"	1" - 11,5		19,5	50,5	24,2	38			
IM32810-20-20	31	- 20	1.1/4"	1.1/4" - 11,5		26,1	61	25	46			
IM32810-24-24	38	- 24	1.1/2"	1.1/2" - 11,5		32,1	62,5	26	50			
IM32810-32-32	51	- 32	2"	2" - 11		42	67	26,5	70			
IM32810-40-40	63	- 40	2.1/2"	2.1/2" - 8		51,5	94,5	43	80			
IM32810-48-48	76	- 48	3"	3" - 8		62,5	123,5	51,5	100			

## SAE STANDARD CONNECTIONS

### IM43310

ISO/SAE CODE 61 FLANGE - SAE J516 / ISO 12151-3 (STAINLESS STEEL)

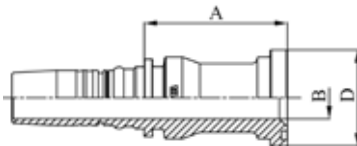

PART. REF.	HOSE BORE			Flange		DIMENSIONS mm						
	DN	Dash	inch			Inch	B	A	D			
IM43310-12-12	19	- 12	3/4"	3/4"		16	60	38				
IM43310-16-16	25	- 16	1"	1"		20	66,5	44,6				
IM43310-20-20	31	- 20	1.1/4"	1.1/4"		26,1	75	51				
IM43310-24-24	38	- 24	1.1/2"	1.1/2"		32,1	80,5	60,5				
IM43310-32-32	51	- 32	2"	2"		42	83	71,6				



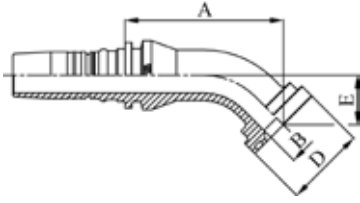

## SAE STANDARD CONNECTIONS

### IM43340

45° ISO/SAE CODE 61 FLANGE - SAE J516 / ISO 12151-3 (STAINLESS STEEL)

PART. REF.	HOSE BORE			Flange	DIMENSIONS mm						
	DN	Dash	inch		Inch	B	A	D	E		
IM43340-12-12	19	- 12	3/4"	3/4"	16	75,5	38	23			
IM43340-16-16	25	- 16	1"	1"	20	87	44,6	27,3			
IM43340-20-20	31	- 20	1.1/4"	1.1/4"	26,1	100,5	51	29,5			
IM43340-24-24	38	- 24	1.1/2"	1.1/2"	32,1	111	60,5	34,5			
IM43340-32-32	51	- 32	2"	2"	42	128,5	71,6	39			

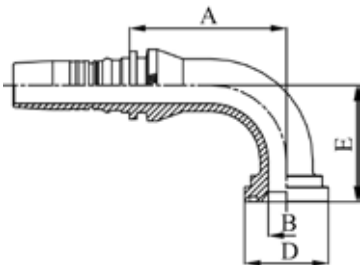

## SAE STANDARD CONNECTIONS

### IM43390

90° ISO/SAE CODE 61 FLANGE - SAE J516 / ISO 12151-3 (STAINLESS STEEL)

PART. REF.	HOSE BORE			Flange	DIMENSIONS mm						
	DN	Dash	inch		Inch	B	A	D	E		
IM43390-12-12	19	- 12	3/4"	3/4"	16	72	38	52			
IM43390-16-16	25	- 16	1"	1"	20	83,5	44,6	62			
IM43390-20-20	31	- 20	1.1/4"	1.1/4"	26,1	99	51	70			
IM43390-24-24	38	- 24	1.1/2"	1.1/2"	32,1	111,5	60,5	84			
IM43390-32-32	51	- 32	2"	2"	42	133,5	71,6	99			

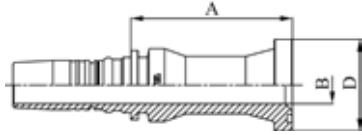

## SAE STANDARD CONNECTIONS

### IM43610

ISO/SAE CODE 62 FLANGE - SAE J516 / ISO 12151-3 (STAINLESS STEEL)

PART. REF.	HOSE BORE			Flange		DIMENSIONS mm						
	DN	Dash	inch	Inch		B	A	D				
IM43610-10-12	16	- 10	5/8"	3/4"		16	65	41,5				
IM43610-10-16	16	- 10	5/8"	1"		20	81,5	47,7				
IM43610-12-12	19	- 12	3/4"	3/4"		16	71,5	41,4				
IM43610-12-16	19	- 12	3/4"	1"		20	83,5	47,7				
IM43610-16-12	25	- 16	1"	3/4"		16	80,3	41,4				
IM43610-16-16	25	- 16	1"	1"		20	84,5	47,7				
IM43610-16-20	25	- 16	1"	1.1/4"		26	89	54,2				
IM43610-20-16	31	- 20	1.1/4"	1"		20	87	47,7				
IM43610-20-20	31	- 20	1.1/4"	1.1/4"		26,1	91	54,2				
IM43610-20-24	31	- 20	1.1/4"	1.1/2"		32,1	97	63,7				
IM43610-24-20	38	- 24	1.1/2"	1.1/4"		26	101	54,2				
IM43610-24-24	38	- 24	1.1/2"	1.1/2"		32,1	97,5	63,7				
IM43610-24-32	38	- 24	1.1/2"	2"		42	113	79,6				
IM43610-32-24	51	- 32	2"	1.1/2"		32,1	117	63,7				
IM43610-32-32	51	- 32	2"	2"		42	113	79,6				
IM43610-40-40	63	- 40	2.1/2"	2.1/2"		51,5	126,5	107,9				
IM43610-48-48	76	- 48	3"	3"		62,5	167	131,9				

**FITTINGS**  
 F 3-42

## SAE STANDARD CONNECTIONS

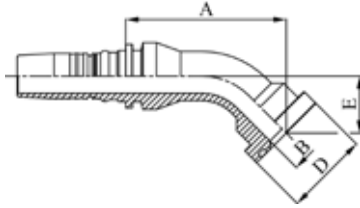

### IM43640

45° ISO/SAE CODE 62 FLANGE - SAE J516 / ISO 12151-3 (STAINLESS STEEL)

PART. REF.	HOSE BORE			Flange		DIMENSIONS mm						
	DN	Dash	inch			Inch	B	A	D			
IM43640-12-12	19	- 12	3/4"	3/4"		16	81	41,4	28			
IM43640-16-16	25	- 16	1"	1"		20	91,5	47,7	32,5			
IM43640-20-20	31	- 20	1.1/4"	1.1/4"		26	108	54,2	37,5			
IM43640-24-24	38	- 24	1.1/2"	1.1/2"		32	124,5	63,7	44			
IM43640-32-32	51	- 32	2"	2"		42	154	79,6	60,5			

## SAE STANDARD CONNECTIONS

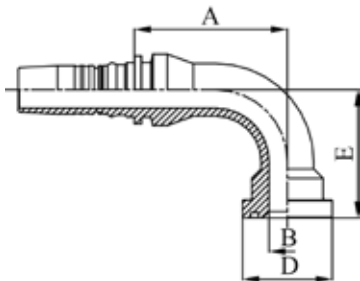

### IM43690

90° ISO/SAE CODE 62 FLANGE - SAE J516 / ISO 12151-3 (STAINLESS STEEL)

PART. REF.	HOSE BORE			Flange		DIMENSIONS mm						
	DN	Dash	inch			Inch	B	A	D			
IM43690-10-12	16	- 10	5/8"	3/4"		16	57,5	41,4	60,5			
IM43690-12-12	19	- 12	3/4"	3/4"		16	72,4	41,4	59			
IM43690-16-16	25	- 16	1"	1"		20	81	47,7	68			
IM43690-20-20	31	- 20	1.1/4"	1.1/4"		26	98,5	54,2	81			
IM43690-24-24	38	- 24	1.1/2"	1.1/2"		32	112,5	63,7	94,5			
IM43690-32-32	51	- 32	2"	2"		42	140,5	79,6	132			

## DIN STANDARD CONNECTIONS

### IM31210

METRIC MALE 24° CONE SEAT HEAVY DUTY - DIN 20066 / ISO 12151-2 (STAINLESS STEEL)

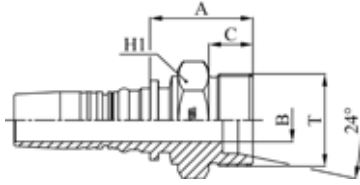

PART. REF.	HOSE BORE			Thread	Pipe	DIMENSIONS mm						
	DN	Dash	inch			T	mm	B	A	C	H1	
IM31210-10-30	16	- 10	5/8"	M 30x2	20	12	37	16	30			
IM31210-12-36	19	- 12	3/4"	M 36x2	25	14,5	43,5	18	36			
IM31210-16-42	25	- 16	1"	M 42x2	30	19,5	46,8	20	46			
IM31210-20-52	31	- 20	1.1/4"	M 52x2	38	25	55	22	55			

## DIN STANDARD CONNECTIONS

### IM41613

METRIC O-RING FEMALE 24° CONE HEAVY DUTY - DIN 20066 / ISO 12151-2 (STAINLESS STEEL)

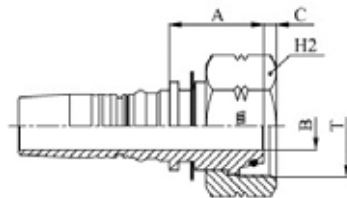

PART. REF.	HOSE BORE			Thread	Pipe	DIMENSIONS mm						
	DN	Dash	inch			T	mm	B	A	C	H2	
IM41613-10-30	16	- 10	5/8"	M 30x2	20	12	37	3,5	36			
IM41613-12-36	19	- 12	3/4"	M 36x2	25	14,5	42	3,4	41			
IM41613-16-42	25	- 16	1"	M 42x2	30	19,5	46,5	5,3	50			
IM41613-20-52	31	- 20	1.1/4"	M 52x2	38	26,1	41,5	8	60			

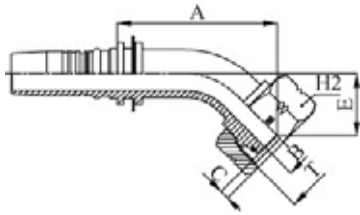

## DIN STANDARD CONNECTIONS

### IM41643

**45° METRIC O-RING FEMALE SWEPT ELBOW 24° CONE HEAVY DUTY  
DIN 20066 / ISO 12151-2 (STAINLESS STEEL)**

PART. REF.	HOSE BORE			Thread	Pipe	DIMENSIONS mm						
	DN	Dash	inch			T	mm	B	A	C	E	H2
IM41643-10-30	16	- 10	5/8"	M 30x2	20	12	66,5	3,5	29,5	36		
IM41643-12-36	19	- 12	3/4"	M 36x2	25	14,5	81	3,4	33,5	41		
IM41643-16-42	25	- 16	1"	M 42x2	30	19,5	93	5,3	36	50		
IM41643-20-52	31	- 20	1.1/4"	M 52x2	38	26,1	110	8	40	60		

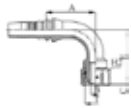

## DIN STANDARD CONNECTIONS

### IM41692/IM41693

**90° METRIC O-RING FEMALE SWEPT ELBOW 24° CONE HEAVY DUTY  
DIN 20066 / ISO 12151-2 (STAINLESS STEEL)**

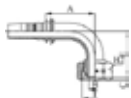

PART. REF.	HOSE BORE			Thread	Pipe	DIMENSIONS mm						
	DN	Dash	inch			T	mm	B	A	C	E	H2
IM41693-10-30	16	- 10	5/8"	M 30x2	20	12	52,5	3,5	57,5	36		
IM41693-12-36	19	- 12	3/4"	M 36x2	25	14,5	67	3,4	67,5	41		
IM41693-16-42	25	- 16	1"	M 42x2	30	19,5	81,5	5,3	75,5	50		
IM41692-20-42	31	- 20	1.1/4"	M 42x2	30	19,1	103,5	6,1	90	50		
IM41693-20-52	31	- 20	1.1/4"	M 52x2	38	26	100	8	86,5	60		

M41692: THRUST-WIRE NUT - M41693: SLIP-ON NUT

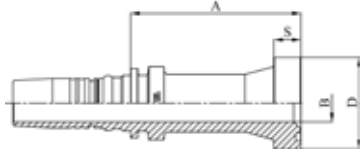

## ORIGINAL EQUIPMENT CONNECTIONS

### IM43910

STRAIGHT SUPERCAT SERIES FLANGE (STAINLESS STEEL)

PART. REF.	HOSE BORE			Flange	DIMENSIONS mm						
	DN	Dash	inch		Inch	B	A	D	S		
IM43910-12-12	19	- 12	3/4"	3/4"		16	77	41,5	14,3		
IM43910-16-16	25	- 16	1"	1"		20	89,5	47,7	14,3		
IM43910-20-20	31	- 20	1.1/4"	1.1/4"		26	95	54	14,3		
IM43910-24-24	38	- 24	1.1/2"	1.1/2"		32,1	99	63,6	14,3		
IM43910-32-32	51	- 32	2"	2"		42	114	79,3	14,3		

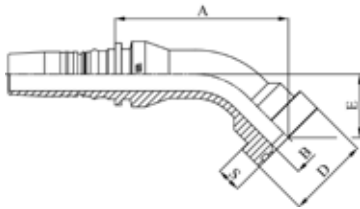

## ORIGINAL EQUIPMENT CONNECTIONS

### IM43940

45° SUPERCAT SERIES FLANGE (STAINLESS STEEL)

PART. REF.	HOSE BORE			Flange	DIMENSIONS mm					
	DN	Dash	inch		Inch	B	A	D	E	S
IM43940-12-12	19	- 12	3/4"	3/4"		16	85	41,5	32	14,3
IM43940-16-16	25	- 16	1"	1"		20	100,5	47,7	36,5	14,3
IM43940-20-20	31	- 20	1.1/4"	1.1/4"		26,1	110,5	54	40,5	14,3
IM43940-24-24	38	- 24	1.1/2"	1.1/2"		32	125,5	63,7	45,5	14,3
IM43940-32-32	51	- 32	2"	2"		42	158,5	79,3	61,5	14,3

ORIGINAL EQUIPMENT CONNECTIONS

**IM43990**

90° SUPERCAT SERIES FLANGE (STAINLESS STEEL)

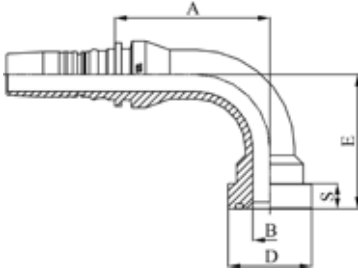

PART. REF.	HOSE BORE			Flange	DIMENSIONS mm						
	DN	Dash	inch		Inch	B	A	D	E	S	
IM43990-12-12	19	- 12	3/4"	3/4"	16	72,5	41,5	64,5	14,3		
IM43990-16-16	25	- 16	1"	1"	20	88,5	47,7	76,5	14,3		
IM43990-20-20	31	- 20	1.1/4"	1.1/4"	26,1	98,5	54	85	14,3		
IM43990-24-24	38	- 24	1.1/2"	1.1/2"	32	112,5	63,7	96	14,3		
IM43990-32-32	51	- 32	2"	2"	42	144	79,3	133,5	14,3		







# INTERLOCK SUPER



FITTING CODE	SECTION	PAGE
JO29 IS	4	2
M02700	4	1
M02800	4	1
MB3610	4	2
MB8510	4	2

## INTERLOCK SUPER

DN	5	6	8	10	12	16	19	25	31	38	51	60	63	76	89	102
Inch	$\frac{3}{16}$ "	$\frac{1}{4}$ "	$\frac{5}{16}$ "	$\frac{3}{8}$ "	$\frac{1}{2}$ "	$\frac{5}{8}$ "	$\frac{3}{4}$ "	1"	$1\frac{1}{4}$ "	$1\frac{1}{2}$ "	2"	$2\frac{3}{8}$ "	$2\frac{1}{2}$ "	3"	$3\frac{1}{2}$ "	4"
Size	-03	-04	-05	-06	-08	-10	-12	-16	-20	-24	-32	-38	-40	-48	-56	-64

### FERRULES

M02700																		
M02800																		

### FITTINGS

SAE FLANGE CODE 62																		
XTRAFLANGE																		

FERRULE

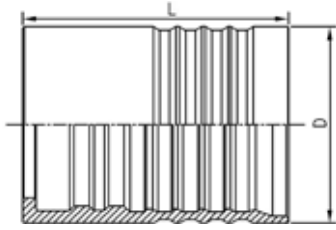

**M02700**

DOUBLE SKIVE FERRULE EXD.8WS

PART. REF.	HOSE BORE			DIMENSIONS mm							
	DN	Dash	inch			D	L				
M02700-48	76	- 48	3"			122	165				

FERRULE

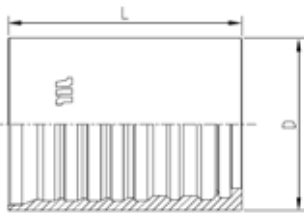

**M02800**

DOUBLE SKIVE FERRULE FOR HEAVY DUTY SPIRAL HOSES (8 PLY)

PART. REF.	HOSE BORE			DIMENSIONS mm							
	DN	Dash	inch			D	L				
M02800-48	76	- 48	3"			122	165				
M02800-56	89	- 56	3.1/2"			149	236,7				

## SAE STANDARD CONNECTIONS

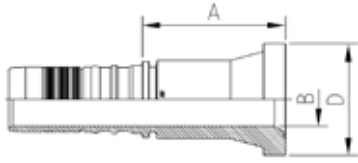

### MB3610

ISO/SAE CODE 62 FLANGE - SAE J516 / ISO 12151-3

PART. REF.	HOSE BORE			Flange	DIMENSIONS mm								
	DN	Dash	inch		Inch	B	A	D					
MB3610-48-48	76	- 48	3"	3"		62,5	169	131,9					

## XTRAFRANGE

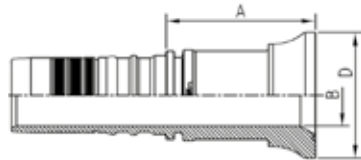

### MB8510

XTRAFRANGE/62 (SAE J518 CODE 62 - ISO 6162-2 PORT COMPATIBLE)

PART. REF.	HOSE BORE			Flange	DIMENSIONS mm								
	DN	Dash	inch		Inch	B	A	D					
MB8510-48-48	76	- 48	3"	3"		62,5	152	128					

## O-RING

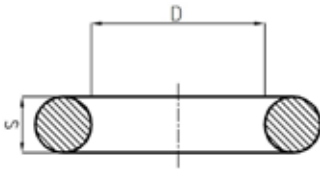

### JO29

INTERLOCK SUPER O-RING

PART. REF.	HOSE BORE			DIMENSIONS mm								
	DN	Dash	inch			D	S					
JO29757026	76	- 48	3"			69,5	2,6					
JO29878226	89	- 56	3.1/2"			82,2	2,6					
JO291029535	102	- 64	4"			94,8	3,5					



**XTRALOCK**





FITTING CODE	SECTION	PAGE
M01750	5	1
M01800	5	1
M52810-M57810	5	2
M53510	5	2
M68510	5	4
M68540	5	5
M68590	5	5
M68610	5	3
M68640	5	4
M68690	5	3

## XTRALOCK

DN	5	6	8	10	12	16	19	25	31	38	51	60	63	76	89	102
Inch	3/16"	1/4"	5/16"	3/8"	1/2"	5/8"	3/4"	1"	1 1/4"	1 1/2"	2"	2 3/8"	2 1/2"	3"	3 1/2"	4"
Size	-03	-04	-05	-06	-08	-10	-12	-16	-20	-24	-32	-38	-40	-48	-56	-64

## FERRULES

M01750																	
M01800																	

## FITTINGS

SAE (NPTF-NPSM)																	
SAE FLANGE CODE 62																	
XTRAFLLANGE																	

FITTINGS  
F 511

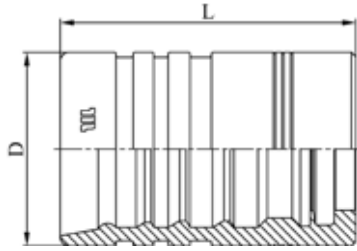

FERRULE

**M01750**

DOUBLE SKIVE FERRULE FOR EXTRA DUTY SPIRAL HOSES (4 PLY)

PART. REF.	HOSE BORE			DIMENSIONS mm								
	DN	Dash	inch			D	L					
M01750-12	19	- 12	3/4"			45,1	69					

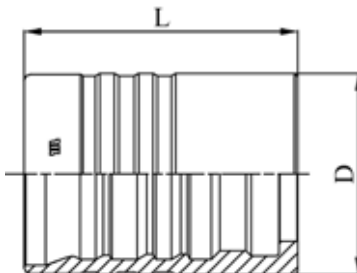

FERRULE

**M01800**

DOUBLE SKIVE FERRULE FOR EXTRA DUTY SPIRAL HOSES (6 PLY)

PART. REF.	HOSE BORE			DIMENSIONS mm								
	DN	Dash	inch			D	L					
M01800-16	25	- 16	1"			53,5	69					
M01800-24	38	- 24	1.1/2"			73	97,8					

## SAE STANDARD CONNECTION

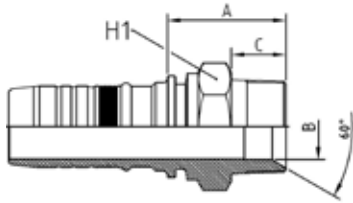

### M52810/M57810

NPTF MALE 60° CONE SEAT - SAE J516/J514 ANSI B1.20.3

PART. REF.	HOSE BORE			Thread		DIMENSIONS mm						
	DN	Dash	inch			T	B	A	C			
M52810-12-12	19	- 12	3/4"	3/4" - 14		15	49,4	21	32			
M57810-16-16	25	- 16	1"	1" - 11		19	60,4	24,2	41			
M57810-20-20	31	- 20	1.1/4"	1.1/4" - 11		26,1	63,9	28	46			
M57810-24-24	38	- 24	1.1/2"	1.1/2" - 11		32,1	70,4	30	55			
M57810-32-32	51	- 32	2"	2" - 11		42	75,5	35	70			
M57810-40-40	63	- 40	2.1/2"	2.1/2" - 8		55,4	94,7	43	80			
M57810-48-48	76	- 48	3"	3" - 8		62,5	123,5	51,5	100			

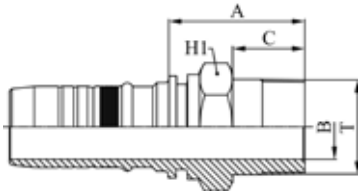

## SAE STANDARD CONNECTIONS

### M53510

NPT MALE - ANSI B1.20.1

PART. REF.	HOSE BORE			Thread		DIMENSIONS mm						
	DN	Dash	inch			T	B	A	C			
M53510-32-32	51	- 32	2"	2" - 11,5		41	119,5	55	70			
M53510-40-40	63	- 40	2.1/2"	2.1/2" - 8		51,5	135	63	80			
M53510-48-48	76	- 48	3"	3" - 8		62,5	143,5	71,5	100			

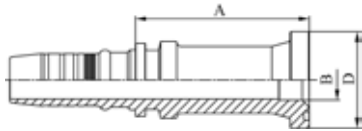

## SAE STANDARD CONNECTIONS

### M68610

ISO/SAE CODE 62 FLANGE - SAE J516 / ISO 12151-3

PART. REF.	HOSE BORE			Flange		DIMENSIONS mm						
	DN	Dash	inch	Inch		B	A	D				
M68610-12-12	19	- 12	3/4"	3/4"		16	74	41,4				
M68610-12-16	19	- 12	3/4"	1"		20	85,5	47,7				
M68610-16-16	25	- 16	1"	1"		20	85	47,7				
M68610-20-20	31	- 20	1.1/4"	1.1/4"		26,1	91	54,2				
M68610-24-24	38	- 24	1.1/2"	1.1/2"		32,1	97,5	63,7				
M68610-32-32	51	- 32	2"	2"		42	112,5	79,6				
M68610-32-40	51	- 32	2"	2.1/2"		51,5	124	107,8				
M68610-40-32	63	- 40	2.1/2"	2"		41	115	79,6				
M68610-40-40	63	- 40	2.1/2"	2.1/2"		51,5	126,5	107,9				
M68610-48-48	76	- 48	3"	3"		62,5	167	131,9				

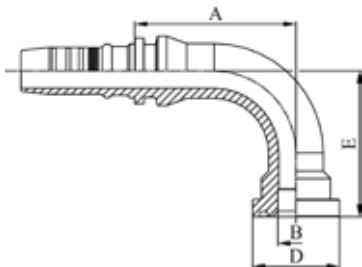

## SAE STANDARD CONNECTIONS

### M68690

90° ISO/SAE CODE 62 FLANGE - SAE J516 / ISO 12151-3

PART. REF.	HOSE BORE			Flange		DIMENSIONS mm						
	DN	Dash	inch	Inch		B	A	D	E			
M68690-12-12	19	- 12	3/4"	3/4"		16	75	41,4	59			
M68690-16-16	25	- 16	1"	1"		20	87	47,7	80			
M68690-20-20	31	- 20	1.1/4"	1.1/4"		24	110	54,2	93			
M68690-24-24	38	- 24	1.1/2"	1.1/2"		30,5	124,5	63,7	109,5			
M68690-32-32	51	- 32	2"	2"		42	148	79,6	135,5			

## SAE STANDARD CONNECTIONS

### M68640

45° ISO/SAE CODE 62 FLANGE - SAE J516 / ISO 12151-3

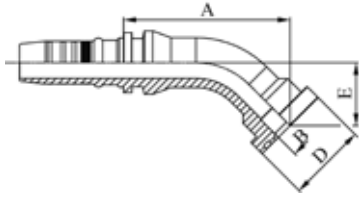

PART. REF.	HOSE BORE			Flange		DIMENSIONS mm						
	DN	Dash	inch	Inch		B	A	D	E			
M68640-12-16	19	- 12	3/4"	1"		20	88	47,7	32			
M68640-16-16	25	- 16	1"	1"		20	98,5	47,7	38			
M68640-20-20	31	- 20	1.1/4"	1.1/4"		24	121,5	54,2	43,5			
M68640-24-24	38	- 24	1.1/2"	1.1/2"		30,5	136	63,7	50			
M68640-32-32	51	- 32	2"	2"		42	160	79,6	61			

## XTRAFRANGE

### M68510

XTRAFRANGE/62 (SAE J518 CODE 62 - ISO 6162-2 PORT COMPATIBLE)

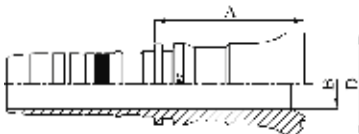

PART. REF.	HOSE BORE			Flange		DIMENSIONS mm						
	DN	Dash	inch	Inch		B	A	D				
M68510-16-16	25	- 16	1"	1"		20	69,5	47,7				
M68510-20-20	31	- 20	1.1/4"	1.1/4"		24	88	54,4				
M68510-20-24	31	- 20	1.1/4"	1.1/2"		30,5	100	63,7				
M68510-24-24	38	- 24	1.1/2"	1.1/2"		30,5	102	63,7				
M68510-32-32	51	- 32	2"	2"		41	129	79,6				
M68510-40-40	63	- 40	2.1/2"	2.1/2"		51,5	149	99,2				

## XTRAFLANGE

### M68590

90° XTRAFLANGE/62 (SAE J518 CODE 62 AND ISO 6162-2 PORT COMPATIBLE)

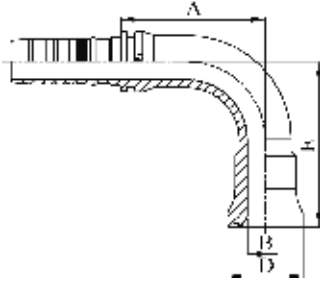

PART. REF.	HOSE BORE			Flange		DIMENSIONS mm						
	DN	Dash	inch	Inch	B	A	D	E				
M68590-16-16	25	- 16	1"	1"	20	84	47,7	90				
M68590-20-20	31	- 20	1.1/4"	1.1/4"	24	107	54,4	120				
M68590-24-24	38	- 24	1.1/2"	1.1/2"	30,5	122	63,7	140				
M68590-24-32	38	- 24	1.1/2"	2"	39	122	79,6	170				
M68590-32-32	51	- 32	2"	2"	39	147,5	79,6	178				

## XTRAFLANGE

### M68540

45° XTRAFLANGE/62 (SAE J518 CODE 62 AND ISO 6162-2 PORT COMPATIBLE)

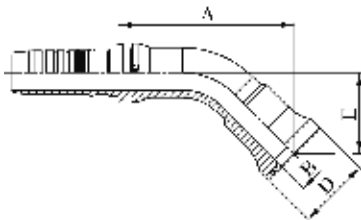

PART. REF.	HOSE BORE			Flange		DIMENSIONS mm						
	DN	Dash	inch	Inch	B	A	D	E				
M68540-16-16	25	- 16	1"	1"	20	103	47,7	45				
M68540-20-20	31	- 20	1.1/4"	1.1/4"	24	138	54,4	62,5				
M68540-24-24	38	- 24	1.1/2"	1.1/2"	30,5	155	63,7	71,5				
M68540-24-32	38	- 24	1.1/2"	2"	39	176,5	79,6	93				
M68540-32-32	51	- 32	2"	2"	39	193,5	79,6	92,5				







# SPIRALFIT



FITTING CODE	SECTION	PAGE
M05400	6	1
M05500	6	1
M70050	6	26
M70510	6	2
M71210	6	17
M72410	6	6
M72510	6	4
M72810	6	9
M73010	6	9
M80812	6	2
M80842	6	3
M80892	6	3
M81612	6	17
M81642-M81643	6	18
M81692-M81693	6	18
M82412	6	7
M82442	6	8
M82492	6	7
M82542	6	5
M82592	6	5
M82712	6	4
M83301P	6	16
M83311	6	10
M83321	6	10
M83331	6	11
M83341	6	11

FITTING CODE	SECTION	PAGE
M83361	6	12
M83371	6	12
M83391	6	13
M83611	6	14
M83631	6	14
M83641	6	15
M83661	6	15
M83691	6	16
M83711	6	19
M83741	6	19
M83791	6	19
M83911	6	20
M83921	6	20
M83931	6	21
M83941	6	21
M83961	6	22
M83971	6	22
M83991	6	23
M83991 LONG DROP	6	23
M84492	6	8
M84792	6	6
M88511	6	24
M88541	6	24
M88591	6	25
M89510WL	6	25

## SPIRALFIT

DN	5	6	8	10	12	16	19	25	31	38	51	60	63	76	89	102
Inch	3/16"	1/4"	5/16"	3/8"	1/2"	5/8"	3/4"	1"	1 1/4"	1 1/2"	2"	2 3/8"	2 1/2"	3"	3 1/2"	4"
Size	-03	-04	-05	-06	-08	-10	-12	-16	-20	-24	-32	-38	-40	-48	-56	-64

## FERRULES

M05400																
M05500																

## FITTINGS

BSP																
SAE (JIC)																
SAE (ORFS)																
SAE																
SAE (NPTF-NPSM)																
SAE FLANGE CODE 61																
SAE FLANGE CODE 62																
DIN METRIC 24° CONE HEAVY TYPE																
ORIGINAL EQUIPMENT CONNECTIONS																
XTRAFEDGE/62																

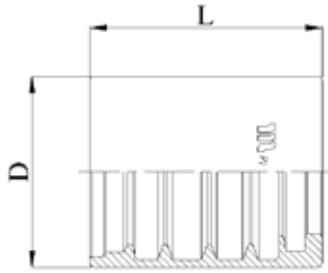

FERRULE

## M05400

NO-SKIVE FERRULE FOR HEAVY DUTY SPIRAL HOSES (4 PLY)

PART. REF.	HOSE BORE			DIMENSIONS mm								
	DN	Dash	inch			D	L					
M05400-10	16	- 10	5/8"			40	44,3					
M05400-12	19	- 12	3/4"			43,8	53,3					
M05400-16	25	- 16	1"			52	64,3					
M05400-20	31	- 20	1.1/4"			59,3	72					
M05400-24	38	- 24	1.1/2"			68,5	78					
M05400-32	51	- 32	2"			84,6	97,1					
M05400-40	63	- 40	2.1/2"			97	116					
M05400-48	76	- 48	3"			109,8	124					
M05400-56	89	- 56	3.1/2"			127,7	123,5					
M05400-64	102	- 64	4"			145	126,5					

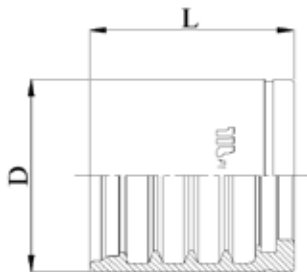

FERRULE

## M05500

NO-SKIVE FERRULE FOR HEAVY DUTY SPIRAL HOSES (4-6 PLY)

PART. REF.	HOSE BORE			DIMENSIONS mm								
	DN	Dash	inch			D	L					
M05500-20	31	- 20	1.1/4"			66	70					
M05500-24	38	- 24	1.1/2"			75	79					
M05500-32	51	- 32	2"			90	98,1					

## BS STANDARD CONNECTIONS

### M70510

BSP MALE PARALLEL 60° CONE SEAT - BS5200 / ISO 12151-6

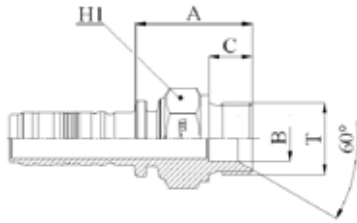

PART. REF.	HOSE BORE			Thread		DIMENSIONS mm						
	DN	Dash	inch			T	B	A	C	H1		
M70510-12-12	19	- 12	3/4"	3/4" - 14		16,8	43,5	16	32			
M70510-12-16	19	- 12	3/4"	1" - 11		22,2	49,5	19	41			
M70510-16-16	25	- 16	1"	1" - 11		22,2	51	19	41			
M70510-16-20	25	- 16	1"	1.1/4" - 11		28,5	56	20	50			
M70510-20-20	31	- 20	1.1/4"	1.1/4" - 11		28,5	56,5	20	50			
M70510-24-24	38	- 24	1.1/2"	1.1/2" - 11		33,5	60,5	22	55			
M70510-32-32	51	- 32	2"	2" - 11		42	64	25	70			

## BS STANDARD CONNECTIONS

### M80812

BSP O-RING FEMALE 60° CONE - BS5200 / ISO 12151-6

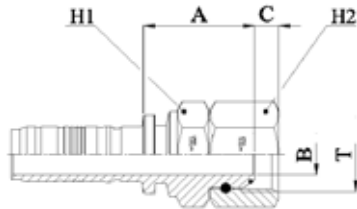

PART. REF.	HOSE BORE			Thread		DIMENSIONS mm						
	DN	Dash	inch			T	B	A	C	H1	H2	
M80812-12-12	19	- 12	3/4"	3/4" - 14		14,5	39,5	8,5	32	32		
M80812-12-16	19	- 12	3/4"	1" - 11		19,5	44	10,6	41	41		
M80812-16-12	25	- 16	1"	3/4" - 14		15	44,5	8,5	41	32		
M80812-16-16	25	- 16	1"	1" - 11		19,5	45,5	10,6	41	41		
M80812-16-20	25	- 16	1"	1.1/4" - 11		26,1	50,5	10,5	50	50		
M80812-20-16	31	- 20	1.1/4"	1" - 11		19	48	10,6	50	41		
M80812-20-20	31	- 20	1.1/4"	1.1/4" - 11		26,1	50,5	10,5	50	50		
M80812-20-24	31	- 20	1.1/4"	1.1/2" - 11		32,1	50	12,5	50	60		
M80812-24-20	38	- 24	1.1/2"	1.1/4" - 11		26,1	52	10,5	55	50		
M80812-24-24	38	- 24	1.1/2"	1.1/2" - 11		32,1	52	12,5	60	60		
M80812-32-32	51	- 32	2"	2" - 11		42	53,5	16,1	70	70		

## BS STANDARD CONNECTIONS

### M80892

90° BSP O-RING FEMALE SWEPT ELBOW 60° CONE - BS5200 / ISO 12151-6

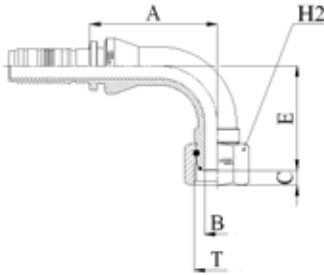

PART. REF.	HOSE BORE			Thread		DIMENSIONS mm						
	DN	Dash	inch			T	B	A	C	E	H2	
M80892-12-12	19	- 12	3/4"	3/4" - 14		14,5	73,5	8,5	60	32		
M80892-12-12050	19	- 12	3/4"	3/4" - 14		14,5	67,5	8,5	50	32		
M80892-12-16	19	- 12	3/4"	1" - 11		19,5	73,5	10,6	62	41		
M80892-16-12	25	- 16	1"	3/4" - 14		15	90	8,5	70	32		
M80892-16-16	25	- 16	1"	1" - 11		19,5	83	10,6	76	41		
M80892-16-16058	25	- 16	1"	1" - 11		19,5	74,5	10,6	58,5	41		
M80892-16-20	25	- 16	1"	1.1/4" - 11		26,1	96	10,5	78,5	50		
M80892-20-16	31	- 20	1.1/4"	1" - 11		19,5	90	10,6	76	41		
M80892-20-20	31	- 20	1.1/4"	1.1/4" - 11		26	88	10,5	83,5	50		
M80892-20-24	31	- 20	1.1/4"	1.1/2" - 11		32	88	12,5	92	60		
M80892-24-24	38	- 24	1.1/2"	1.1/2" - 11		32	103	12,5	98,5	60		
M80892-32-32	51	- 32	2"	2" - 11		42	135,9	16,1	140,5	70		

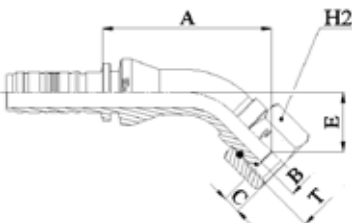

## BS STANDARD CONNECTIONS

### M80842

45° BSP O-RING FEMALE SWEPT ELBOW 60° CONE BS5200 / ISO 12151-6

PART. REF.	HOSE BORE			Thread		DIMENSIONS mm						
	DN	Dash	inch			T	B	A	C	E	H2	
M80842-12-12	19	- 12	3/4"	3/4" - 14		14,5	82,5	8,5	29	32		
M80842-12-16	19	- 12	3/4"	1" - 11		19,5	84	10,6	30	41		
M80842-16-12	25	- 16	1"	3/4" - 14		15	106,5	8,5	36	32		
M80842-16-16	25	- 16	1"	1" - 11		19,5	95	10,6	36,5	41		
M80842-16-16028	25	- 16	1"	1" - 11		19,5	84	10,6	28	41		
M80842-16-20	25	- 16	1"	1.1/4" - 11		26,1	109,5	10,5	38	50		
M80842-20-16	31	- 20	1.1/4"	1" - 11		19,5	102	10,6	36,5	41		
M80842-20-20	31	- 20	1.1/4"	1.1/4" - 11		26	99	10,5	39	50		
M80842-20-24	31	- 20	1.1/4"	1.1/2" - 11		32	114	12,5	54	60		
M80842-24-24	38	- 24	1.1/2"	1.1/2" - 11		32	112,5	12,5	45	60		
M80842-32-32	51	- 32	2"	2" - 11		42	155	16,1	66	70		

## SAE STANDARD CONNECTIONS

### M72510

JIC MALE 37° CONE - SAE J516 / ISO 12151-5

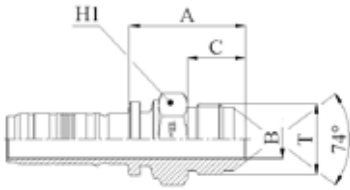

PART. REF.	HOSE BORE			Thread		DIMENSIONS mm						
	DN	Dash	inch			T	B	A	C	H1		
M72510-12-12	19	- 12	3/4"	1.1/16" - 12		14,5	44,5	22	30			
M72510-16-16	25	- 16	1"	1.5/16" - 12		19,5	51,5	23	38			
M72510-20-20	31	- 20	1.1/4"	1.5/8" - 12		26,1	56	24,3	46			
M72510-24-24	38	- 24	1.1/2"	1.7/8" - 12		32,1	60	27,5	50			
M72510-32-32	51	- 32	2"	2.1/2" - 12		42	75,5	34	65			

## SAE STANDARD CONNECTIONS

### M82712

JIC FEMALE 37° CONE SEAT DOUBLE HEXAGON SAE J516 / ISO 12151-5 (THRUST-WIRE NUT)

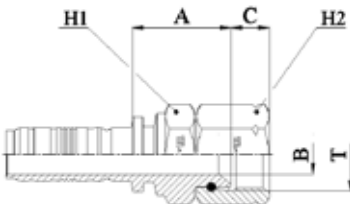

PART. REF.	HOSE BORE			Thread		DIMENSIONS mm						
	DN	Dash	inch			T	B	A	C	H1	H2	
M82712-12-12	19	- 12	3/4"	1.1/16" - 12		14,5	36,5	14,2	32	32		
M82712-12-16	19	- 12	3/4"	1.5/16" - 12		19,5	36,5	15,2	32	41		
M82712-16-16	25	- 16	1"	1.5/16" - 12		19,5	41,5	15,2	41	41		
M82712-16-20	25	- 16	1"	1.5/8" - 12		26,1	46,5	16,2	41	50		
M82712-20-20	31	- 20	1.1/4"	1.5/8" - 12		26,1	51,5	16,2	50	50		
M82712-20-24	31	- 20	1.1/4"	1.7/8" - 12		32	54,5	18,8	55	60		
M82712-24-24	38	- 24	1.1/2"	1.7/8" - 12		32,1	54,5	18,8	55	60		
M82712-32-32	51	- 32	2"	2.1/2" - 12		42	56	24	65	75		



## SAE STANDARD CONNECTIONS

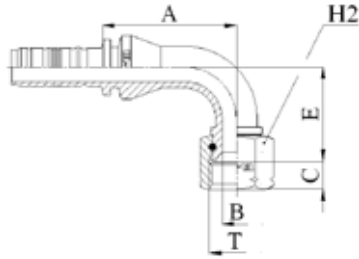

### M82592

**90° JIC FEMALE SWEPT ELBOW 37° CONE SEAT - SAE J516 / ISO 12151-5**

PART. REF.	HOSE BORE			Thread		DIMENSIONS mm						
	DN	Dash	inch			T	B	A	C	E		
M82592-12-12	19	- 12	3/4"	1.1/16" - 12		14,5	67,5	14,2	47,5	32		
M82592-12-16	19	- 12	3/4"	1.5/16" - 12		19,8	73,5	15,2	57,5	41		
M82592-16-12	25	- 16	1"	1.1/16" - 12		14,5	76,5	14,2	47,5	32		
M82592-16-16	25	- 16	1"	1.5/16" - 12		19,5	74,5	15,2	55,5	41		
M82592-20-20	31	- 20	1.1/4"	1.5/8" - 12		26	88	16,2	86,5	50		
M82592-20-24	31	- 20	1.1/4"	1.7/8" - 12		32	88	18,8	90,5	60		
M82592-24-24	38	- 24	1.1/2"	1.7/8" - 12		32,1	105	18,8	101	60		
M82592-32-32	51	- 32	2"	2.1/2" - 12		42	145	24	139	75		

## SAE STANDARD CONNECTIONS

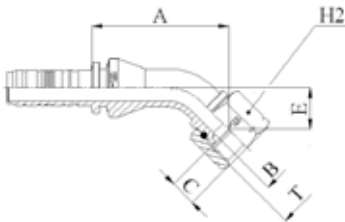

### M82542

**45° JIC FEMALE SWEPT ELBOW 37° CONE SEAT - SAE J516 / ISO 12151-5**

PART. REF.	HOSE BORE			Thread		DIMENSIONS mm						
	DN	Dash	inch			T	B	A	C	E		
M82542-12-12	19	- 12	3/4"	1.1/16" - 12		14,5	75	14,2	22,5	32		
M82542-16-16	25	- 16	1"	1.5/16" - 12		19,5	81,5	15,2	26	41		
M82542-20-20	31	- 20	1.1/4"	1.5/8" - 12		26	101	16,2	41,5	50		
M82542-24-24	38	- 24	1.1/2"	1.7/8" - 12		32,1	121,5	18,8	48,5	60		
M82542-32-32	51	- 32	2"	2.1/2" - 12		42	162	24	63,5	75		

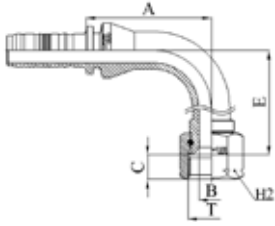

## SAE STANDARD CONNECTIONS

### M84792

90° JIC FEMALE LONG DROP ELBOW 37° CONE SEAT - SAE J516 / ISO 12151-5

PART. REF.	HOSE BORE			Thread		DIMENSIONS mm						
	DN	Dash	inch			T	B	A	C	E	H2	
M84792-12-12	19	- 12	3/4"	1.1/16" - 12		14,5	73,5	14,2	94,5	32		
M84792-16-16	25	- 16	1"	1.5/16" - 12		19,5	81	15,2	114	41		
M84792-20-20	31	- 20	1.1/4"	1.5/8" - 12		26	88	16,2	129	50		
M84792-24-24	38	- 24	1.1/2"	1.7/8" - 12		32,1	105	18,8	141	60		
M84792-32-32	38	- 24	1.1/2"	2.1/2" - 12		42	145	24	222	75		

FITTINGS F 66

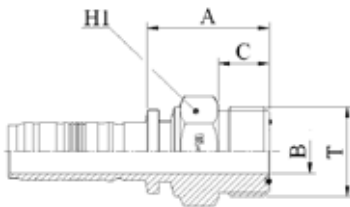

## SAE STANDARD CONNECTIONS

### M72410

ORFS MALE - SAE J516 / ISO 12151-1

PART. REF.	HOSE BORE			Thread		DIMENSIONS mm					
	DN	Dash	inch			T	B	A	C	H1	
M72410-12-12	19	- 12	3/4"	1.3/16" - 12		14,5	41	17	32		
M72410-16-16	25	- 16	1"	1.7/16" - 12		19,5	46	17,5	41		
M72410-20-20	31	- 20	1.1/4"	1.11/16" - 12		26	50,5	17,5	46		
M72410-24-24	38	- 24	1.1/2"	2" - 12		32	53	17,5	55		

## SAE STANDARD CONNECTIONS

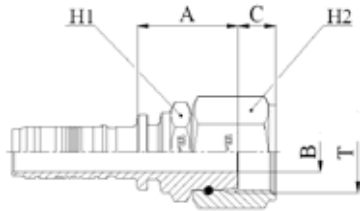

### M82412

ORFS FEMALE SAE J516/ISO 12151.1

PART. REF.	HOSE BORE			Thread	DIMENSIONS mm							
	DN	Dash	inch		T	B	A	C	H1	H2		
M82412-12-12	19	- 12	3/4"	1.3/16" - 12		14,5	38	14,1	32	36		
M82412-12-16	19	- 12	3/4"	1.7/16" - 12		19,5	42	15	41	46		
M82412-16-16	25	- 16	1"	1.7/16" - 12		19,5	43	15	41	46		
M82412-20-20	31	- 20	1.1/4"	1.11/16" - 12		25	52,5	15,1	50	55		
M82412-24-24	38	- 24	1.1/2"	2" - 12		30,5	55	15	60	60		

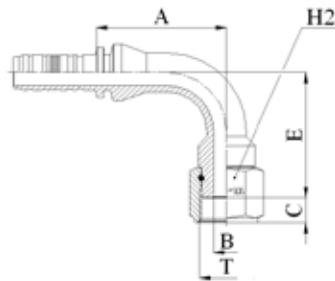

## SAE STANDARD CONNECTIONS

### M82492

90° ORFS FEMALE SWEPT ELBOW SAE J516/ISO 12151-1

PART. REF.	HOSE BORE			Thread	DIMENSIONS mm							
	DN	Dash	inch		T	B	A	C	E	H2		
M82492-12-12	19	- 12	3/4"	1.3/16" - 12		14,5	73,5	14,1	70,5	36		
M82492-12-16	19	- 12	3/4"	1.7/16" - 12		19,5	86	15	71	46		
M82492-16-12	25	- 16	1"	1.3/16" - 12		14,5	89,5	14,1	70,5	36		
M82492-16-16	25	- 16	1"	1.7/16" - 12		19,5	83	15	84,5	46		
M82492-20-20	31	- 20	1.1/4"	1.11/16" - 12		25	99	15,1	98	55		
M82492-24-24	38	- 24	1.1/2"	2" - 12		32	105	15	104	60		

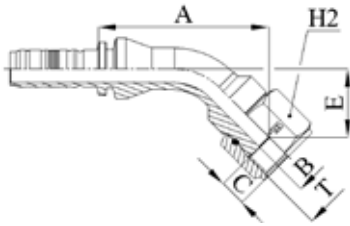

## SAE STANDARD CONNECTIONS

### M82442

45° ORFS FEMALE SWEPT ELBOW SAE J516/ISO 12151-1

PART. REF.	HOSE BORE			Thread		DIMENSIONS mm						
	DN	Dash	inch			T	B	A	C	E	H2	
M82442-12-12	19	- 12	3/4"	1.3/16" - 12		14,5	90	14,1	36	36		
M82442-12-16	19	- 12	3/4"	1.7/16" - 12		19,5	90,5	15	36,5	46		
M82442-16-16	25	- 16	1"	1.7/16" - 12		19,5	101	15	42,5	46		
M82442-20-20	31	- 20	1.1/4"	1.11/16" - 12		25	120	15,1	49,5	55		
M82442-24-24	38	- 24	1.1/2"	2" - 12		32	123,5	15	50,5	60		

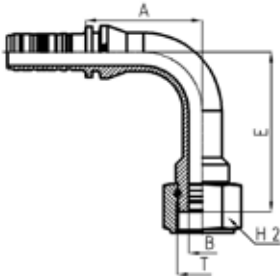

## SAE STANDARD CONNECTIONS

### M84492

90° ORFS FEMALE LONG DROP ELBOW - SAE J516 / ISO 12151-1  
(THURST- WIRE NUT)

PART. REF.	HOSE BORE			Thread		DIMENSIONS mm						
	DN	Dash	inch			T	B	A	C	E	H2	
M84492-12-12	19	- 12	3/4"	1.3/16" - 12		14,5	73,5	14,1	96	36		
M84492-16-16	25	- 16	1"	1.7/16" - 12		19,5	83	15	114	46		
M84492-20-20	31	- 20	1.1/4"	1.11/16" - 12		25	99	15,1	129	55		

## SAE STANDARD CONNECTIONS

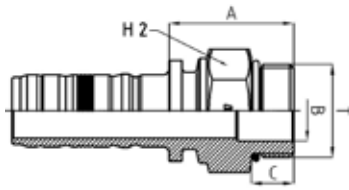

### M73010

SAE MALE O-RING BOSS TYPE - SAE J516 / ISO 11926

PART. REF.	HOSE BORE			Thread	DIMENSIONS mm						
	DN	Dash	inch		T	B	A	C	H1		
M73010-12-12	19	- 12	3/4"	1.1/16" - 12	15,5	42,5	15,1	32			
M73010-16-16	25	- 16	1"	1.5/16" - 12	21,5	44,5	15,1	38			
M73010-20-20	31	- 20	1.1/4"	1.5/8" - 12	27,5	47,5	15,1	46			

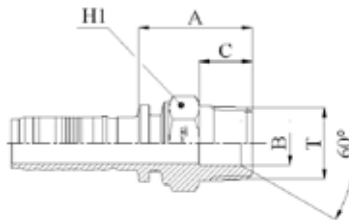

## SAE STANDARD CONNECTIONS

### M72810

NPTF MALE 60° CONE SEAT - SAE J516/J514

PART. REF.	HOSE BORE			Thread	DIMENSIONS mm						
	DN	Dash	inch		T	B	A	C	H1		
M72810-12-12	19	- 12	3/4"	3/4" - 14	16	41,5	19,2	30			
M72810-16-16	25	- 16	1"	1" - 11,5	19,5	52	24,2	38			
M72810-20-20	31	- 20	1.1/4"	1.1/4" - 11,5	25	61,5	25	46			
M72810-24-24	38	- 24	1.1/2"	1.1/2" - 11,5	30,5	60,5	26	50			
M72810-32-32	51	- 32	2"	2" - 11,5	41	67,5	26,5	65			
M72810-48-48	76	- 48	3"	3" - 8	62,5	121,5	51,5	100			

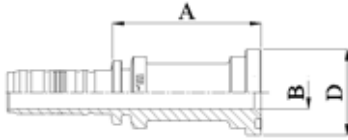

## SAE STANDARD CONNECTIONS

### M83311

ISO/SAE CODE 61 FLANGE - SAE J516 / ISO 12151-3

PART. REF.	HOSE BORE			Flange	DIMENSIONS mm							
	DN	Dash	inch		Inch	B	A	D				
M83311-12-12	19	- 12	3/4"	3/4"		14,5	66,5	38				
M83311-12-16	19	- 12	3/4"	1"		19,5	52,5	44,6				
M83311-16-12	25	- 16	1"	3/4"		14,5	67,5	38				
M83311-16-16	25	- 16	1"	1"		19,5	67,5	44,6				
M83311-16-20	25	- 16	1"	1.1/4"		26	53,5	51				
M83311-20-16	31	- 20	1.1/4"	1"		19,5	69	44,6				
M83311-20-20	31	- 20	1.1/4"	1.1/4"		26	75	51				
M83311-20-24	31	- 20	1.1/4"	1.1/2"		32	60	60,5				
M83311-24-24	38	- 24	1.1/2"	1.1/2"		32	78,5	60,5				
M83311-24-32	38	- 24	1.1/2"	2"		42	60,5	71,6				
M83311-32-32	51	- 32	2"	2"		42	82,5	71,6				
M83311-40-40	63	- 40	2.1/2"	2.1/2"		51,5	93	84,3				
M83311-48-48	76	- 48	3"	3"		62,5	88,5	101,6				
M83311-56-56	89	- 56	3.1/2"	3.1/2"		76	98,5	114,3				
M83311-64-64	102	- 64	4"	4"		89	105	127				

## SAE STANDARD CONNECTIONS

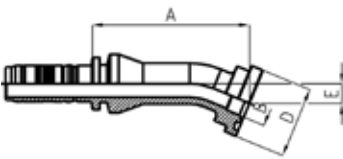

### M83321

22,5° ISO/SAE CODE 61 FLANGE

PART. REF.	HOSE BORE			Flange	DIMENSIONS mm							
	DN	Dash	inch		Inch	B	A	D	E			
M83321-12-12	19	- 12	3/4"	3/4"		16	84,5	38	11			
M83321-16-16	25	- 16	1"	1"		19,5	93	44,6	14			
M83321-16-20	25	- 16	1"	1.1/4"		26	101	51	15			
M83321-20-20	31	- 20	1.1/4"	1.1/4"		26	94,5	51	15			
M83321-24-24	38	- 24	1.1/2"	1.1/2"		32	112,5	60,5	18			
M83321-32-32	51	- 32	2"	2"		42	158	71,6	22			

## SAE STANDARD CONNECTIONS

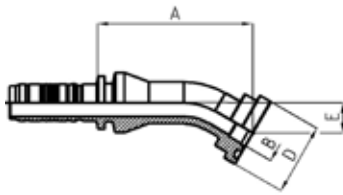

### M83331

30° ISO/SAE CODE 61 FLANGE

PART. REF.	HOSE BORE			Flange	DIMENSIONS mm						
	DN	Dash	inch		B	A	D	E			
M83331-12-12	19	- 12	3/4"	3/4"	16	82,5	38	16			
M83331-12-16	19	- 12	3/4"	1"	19,5	83,5	44,6	19			
M83331-16-16	25	- 16	1"	1"	19,5	91,1	44,6	19			
M83331-24-24	38	- 24	1.1/2"	1.1/2"	32	109,5	60,5	25			
M83331-24-32	38	- 24	1.1/2"	2"	42	111,5	71,6	32			
M83331-32-32	51	- 32	2"	2"	42	154	71,6	32			

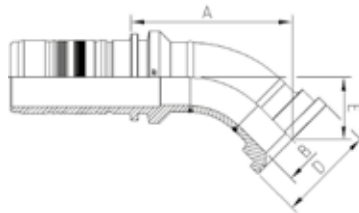

## SAE STANDARD CONNECTIONS

### M83341

45° ISO/SAE CODE 61 FLANGE - SAE J516 / ISO 12151-3

PART. REF.	HOSE BORE			Flange	DIMENSIONS mm						
	DN	Dash	inch		B	A	D	E			
M83341-12-12	19	- 12	3/4"	3/4"	16	78	38	24,5			
M83341-12-16	19	- 12	3/4"	1"	19,5	78	44,6	24,5			
M83341-16-12	25	- 16	1"	3/4"	16	90,5	38	24,5			
M83341-16-16	25	- 16	1"	1"	19,5	86,5	44,6	26,5			
M83341-16-20	25	- 16	1"	1.1/4"	26	92	51	32			
M83341-20-16	31	- 20	1.1/4"	1"	19,5	90,5	44,6	26,5			
M83341-20-20	31	- 20	1.1/4"	1.1/4"	26	87,5	51	29			
M83341-20-24	31	- 20	1.1/4"	1.1/2"	32	88,5	60,5	30			
M83341-24-24	38	- 24	1.1/2"	1.1/2"	32	102,5	60,5	38			
M83341-24-32	38	- 24	1.1/2"	2"	42	102,5	71,6	38			
M83341-32-32	51	- 32	2"	2"	42	143,5	71,6	52			
M83341-40-40	63	- 40	2.1/2"	2.1/2"	49,2	131	84,3	44,5			
M83341-48-48	76	- 48	3"	3"	59	147	101,6	53			
M83341-56-56	89	- 56	3.1/2"	3.1/2"	73,7	169	114,3	68			

All items are made from solid with the exception of M83341-40-40, M83341-48-48 and M83341-56-56

## SAE STANDARD CONNECTIONS

### M83361

60° ISO/SAE CODE 61 FLANGE

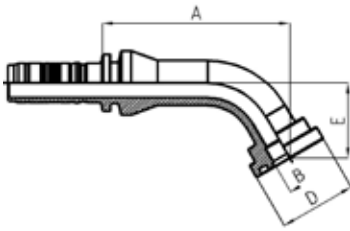

PART. REF.	HOSE BORE			Flange	DIMENSIONS mm						
	DN	Dash	inch		Inch	B	A	D	E		
M83361-12-12	19	- 12	3/4"	3/4"	16	92,5	38	37			
M83361-12-16	19	- 12	3/4"	1"	19,5	106,5	44,6	44			
M83361-16-16	25	- 16	1"	1"	19,5	104,3	44,6	44			
M83361-24-24	38	- 24	1.1/2"	1.1/2"	32	129	60,5	53			
M83361-24-32	38	- 24	1.1/2"	2"	42	123	71,6	75			
M83361-32-32	51	- 32	2"	2"	42	188	71,6	75			

## SAE STANDARD CONNECTIONS

### M83371

67,5° ISO/SAE CODE 61 FLANGE

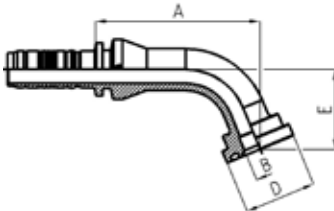

PART. REF.	HOSE BORE			Flange	DIMENSIONS mm						
	DN	Dash	inch		Inch	B	A	D	E		
M83371-12-12	19	- 12	3/4"	3/4"	16	87,5	38	42			
M83371-16-16	25	- 16	1"	1"	19,5	97,5	44,6	51			
M83371-24-24	38	- 24	1.1/2"	1.1/2"	32	122	60,5	61			



## SAE STANDARD CONNECTIONS

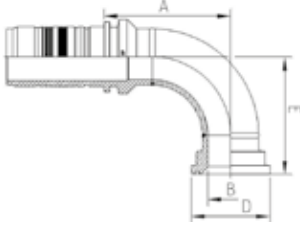

### M83391

90° ISO/SAE CODE 61 FLANGE - SAE J516 / ISO 12151-3

PART. REF.	HOSE BORE			Flange		DIMENSIONS mm						
	DN	Dash	inch			Inch	B	A	D	E		
M83391-12-12	19	- 12	3/4"	3/4"		16	72,5	38	58			
M83391-12-16	19	- 12	3/4"	1"		19,5	72,5	44,6	70			
M83391-12-16054	19	- 12	3/4"	1"		19,5	72,5	44,6	54			
M83391-16-12	25	- 16	1"	3/4"		16	85	38	58			
M83391-16-16	25	- 16	1"	1"		19,5	82	44,6	60			
M83391-16-20	25	- 16	1"	1.1/4"		26	82	51	68			
M83391-20-16	31	- 20	1.1/4"	1"		19,5	86	44,6	60			
M83391-20-20	31	- 20	1.1/4"	1.1/4"		26	85	51	67			
M83391-20-24	31	- 20	1.1/4"	1.1/2"		32	85	60,5	69			
M83391-24-24	38	- 24	1.1/2"	1.1/2"		32	96,5	60,5	81			
M83391-24-32	38	- 24	1.1/2"	2"		42	101,5	71,6	84			
M83391-32-32	51	- 32	2"	2"		42	135,5	71,6	120			
M83391-40-40	63	- 40	2.1/2"	2.1/2"		49,2	128	84,3	118			
M83391-48-48	76	- 48	3"	3"		59	144,5	101,6	140			
M83391-56-56	89	- 56	3.1/2"	3.1/2"		73,7	164	114,3	160			

All items are made from solid with the exception of M83391-40-40, M83391-48-48 and M83391-56-56

## SAE STANDARD CONNECTIONS

### M83611

ISO/SAE CODE 62 FLANGE - SAE J516 / ISO 12151-3

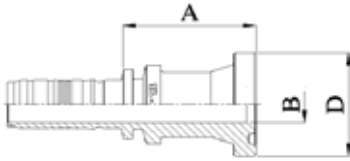

PART. REF.	HOSE BORE			Flange	DIMENSIONS mm							
	DN	Dash	inch		Inch	B	A	D				
M83611-12-12	19	- 12	3/4"	3/4"		14,5	53,5	41,4				
M83611-12-16	19	- 12	3/4"	1"		19,5	59,5	47,7				
M83611-16-12	25	- 16	1"	3/4"		16	62,5	41,4				
M83611-16-16	25	- 16	1"	1"		19,5	63,5	47,7				
M83611-16-20	25	- 16	1"	1.1/4"		26	70	54,2				
M83611-20-16	31	- 20	1.1/4"	1"		19,5	62	47,7				
M83611-20-20	31	- 20	1.1/4"	1.1/4"		26	66	54,2				
M83611-20-24	31	- 20	1.1/4"	1.1/2"		32	74,5	63,7				
M83611-24-20	38	- 24	1.1/2"	1.1/4"		26	66,5	54,2				
M83611-24-24	38	- 24	1.1/2"	1.1/2"		32	74,5	63,7				
M83611-24-32	38	- 24	1.1/2"	2"		42	88,5	79,6				
M83611-32-24	51	- 32	2"	1.1/2"		32	91,5	63,7				
M83611-32-32	51	- 32	2"	2"		42	91,5	79,6				

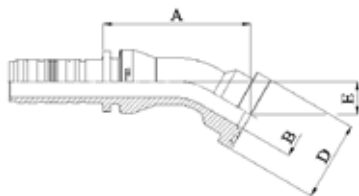

## SAE STANDARD CONNECTIONS

### M83631

30° ISO/SAE CODE 62 FLANGE - SAE J516 / ISO 12151-3

PART. REF.	HOSE BORE			Flange	DIMENSIONS mm							
	DN	Dash	inch		Inch	B	A	D	E			
M83631-12-12	19	- 12	3/4"	3/4"		16	78,5	41,4	17,5			
M83631-16-16	25	- 16	1"	1"		19,5	89	47,7	20			
M83631-20-20	31	- 20	1.1/4"	1.1/4"		26	90,5	54,2	22,5			
M83631-24-24	38	- 24	1.1/2"	1.1/2"		32	104,5	63,7	27			
M83631-32-32	51	- 32	2"	2"		42	139,5	79,6	35			

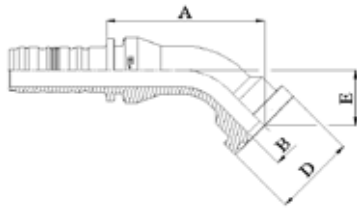

## SAE STANDARD CONNECTIONS

### M83641

45° ISO/SAE CODE 62 FLANGE - SAE J516 / ISO 12151-3

PART. REF.	HOSE BORE			Flange	DIMENSIONS mm						
	DN	Dash	inch		Inch	B	A	D	E		
M83641-12-12	19	- 12	3/4"	3/4"	16	81,5	41,4	28			
M83641-12-16	19	- 12	3/4"	1"	19,5	85,5	47,7	32,5			
M83641-16-12	25	- 16	1"	3/4"	16	87,5	41,4	28			
M83641-16-16	25	- 16	1"	1"	19,5	92	47,7	32,5			
M83641-16-20	25	- 16	1"	1.1/4"	26	97	54,2	37			
M83641-20-16	31	- 20	1.1/4"	1"	19,5	95,5	47,7	31,5			
M83641-20-20	31	- 20	1.1/4"	1.1/4"	26	96,5	54,2	38			
M83641-20-24	31	- 20	1.1/4"	1.1/2"	32	104,5	63,7	44,5			
M83641-24-20	38	- 24	1.1/2"	1.1/4"	26	110,5	54,2	38			
M83641-24-24	38	- 24	1.1/2"	1.1/2"	32	109,5	63,7	44			
M83641-24-32	38	- 24	1.1/2"	2"	42	121,5	79,6	56			
M83641-32-32	51	- 32	2"	2"	42	148	79,6	59			

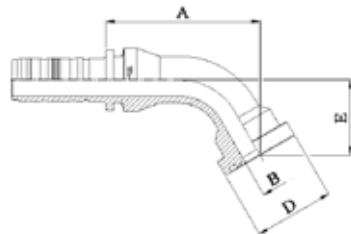

## SAE STANDARD CONNECTIONS

### M83661

60° ISO/SAE CODE 62 FLANGE - SAE J516 / ISO 12151-3

PART. REF.	HOSE BORE			Flange	DIMENSIONS mm						
	DN	Dash	inch		Inch	B	A	D	E		
M83661-12-12	19	- 12	3/4"	3/4"	16	81	41,4	39			
M83661-12-16	19	- 12	3/4"	1"	19,5	84	47,7	44			
M83661-16-16	25	- 16	1"	1"	19,5	92	47,7	45			
M83661-20-20	31	- 20	1.1/4"	1.1/4"	26	97,5	54,2	55			
M83661-20-24	31	- 20	1.1/4"	1.1/2"	32	101,5	63,7	62			
M83661-24-24	38	- 24	1.1/2"	1.1/2"	32	110,5	63,7	61,5			
M83661-32-32	51	- 32	2"	2"	42	151	79,6	85			

## SAE STANDARD CONNECTIONS

### M83691

90° ISO/SAE CODE 62 FLANGE - SAE J516 / ISO 12151-3

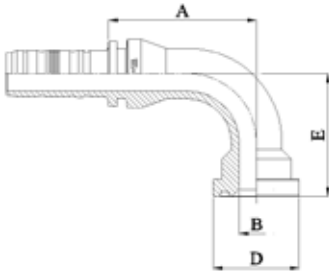

PART. REF.	HOSE BORE			Flange	DIMENSIONS mm						
	DN	Dash	inch		Inch	B	A	D	E		
M83691-12-12	19	- 12	3/4"	3/4"	16	72,5	41,4	59			
M83691-12-16	19	- 12	3/4"	1"	19,5	72,6	47,7	65			
M83691-16-12	25	- 16	1"	3/4"	16	82	41,4	62			
M83691-16-16	25	- 16	1"	1"	19,5	82	47,7	68			
M83691-16-20	25	- 16	1"	1.1/4"	26	82	54,2	90			
M83691-16-20075	25	- 16	1"	1.1/4"	26	82	54,2	75			
M83691-20-16	31	- 20	1.1/4"	1"	19,5	86	47,7	68			
M83691-20-20	31	- 20	1.1/4"	1.1/4"	26	85	54,2	90			
M83691-20-24	31	- 20	1.1/4"	1.1/2"	32	85	63,7	104			
M83691-24-20	38	- 24	1.1/2"	1.1/4"	26	99	54,2	90			
M83691-24-24	38	- 24	1.1/2"	1.1/2"	32	98	63,7	104			
M83691-24-32	38	- 24	1.1/2"	2"	42	98	79,6	138			
M83691-32-32	51	- 32	2"	2"	42	136	79,6	138			

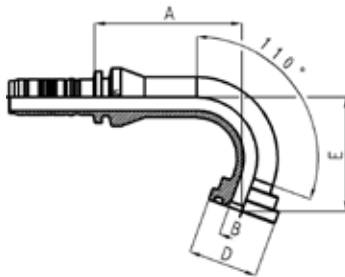

## SAE STANDARD CONNECTIONS

### M83301...P

110° ISO/SAE CODE 61 FLANGE

PART. REF.	HOSE BORE			Flange	DIMENSIONS mm						
	DN	Dash	inch		Inch	B	A	D	E		
M83301-12-12P	19	- 12	3/4"	3/4"	16	80	38	62			
M83301-16-16P	25	- 16	1"	1"	19,5	91,5	44,6	79			
M83301-20-20P	31	- 20	1.1/4"	1.1/4"	26	121,5	51	91			
M83301-24-24P	38	- 24	1.1/2"	1.1/2"	32	124,8	60,5	109			
M83301-32-32P	51	- 32	2"	2"	42	146,5	71,6	140			

## DIN STANDARD CONNECTIONS

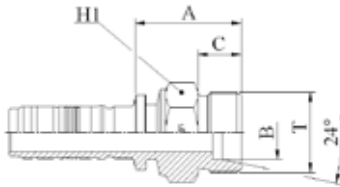

### M71210

**METRIC MALE 24° CONE SEAT HEAVY DUTY**  
- DIN 20066 / ISO 12151-2

PART. REF.	HOSE BORE			Thread	Pipe	DIMENSIONS mm						
	DN	Dash	inch			T	mm	B	A	C	H1	
M71210-12-30	19	- 12	3/4"	M 30x2	20	14,5	39,5	16	32			
M71210-12-36	19	- 12	3/4"	M 36x2	25	14,5	44,5	18	36			
M71210-16-36	25	- 16	1"	M 36x2	25	19,5	46	18	36			
M71210-16-42	25	- 16	1"	M 42x2	30	19,5	47,5	20	46			
M71210-20-52	31	- 20	1.1/4"	M 52x2	38	25	55	22	55			
M71210-24-52	38	- 24	1.1/2"	M 52x2	38	30,5	55,5	22	55			

## DIN STANDARD CONNECTIONS

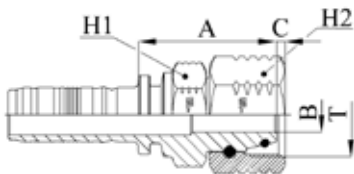

### M81612

**METRIC O-RING FEMALE 24° CONE HEAVY DUTY - DIN 20066 /**  
**ISO 12151-2**

PART. REF.	HOSE BORE			Thread	Pipe	DIMENSIONS mm						
	DN	Dash	inch			T	mm	B	A	C	H1	H2
M81612-12-30	19	- 12	3/4"	M 30x2	20	12,5	49,5	3,2	32	36		
M81612-12-36	19	- 12	3/4"	M 36x2	25	14,5	52	4,1	36	41		
M81612-12-42	19	- 12	3/4"	M 42x2	30	19,5	52,5	6	41	50		
M81612-16-36	25	- 16	1"	M 36x2	25	16	56	4,1	41	41		
M81612-16-42	25	- 16	1"	M 42x2	30	19,5	54,5	6	41	50		
M81612-16-52	25	- 16	1"	M 52x2	38	25	56	8,8	50	60		
M81612-20-42	31	- 20	1.1/4"	M 42x2	30	19,5	56	6,1	46	50		
M81612-20-52	31	- 20	1.1/4"	M 52x2	38	25	57	8,8	50	60		
M81612-24-52	38	- 24	1.1/2"	M 52x2	38	26,1	58	8,8	55	60		

## DIN STANDARD CONNECTIONS

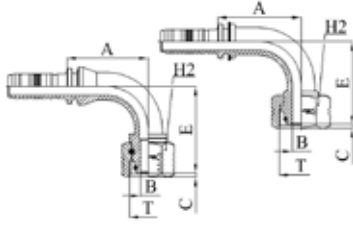

### M81692/M81693

**90° METRIC O-RING FEMALE SWEPT ELBOW 24° CONE HEAVY DUTY  
DIN 20066 / ISO 12151-2**

PART. REF.	HOSE BORE			Thread	Pipe	DIMENSIONS mm						
	DN	Dash	inch			T	mm	B	A	C	E	H2
M81692-12-30	19	- 12	3/4"	M 30x2	20	12,5	64,5	3,2	68,5	36		
M81693-12-36	19	- 12	3/4"	M 36x2	25	14,5	68	3,4	67,5	41		
M81692-16-36	25	- 16	1"	M 36x2	25	15	83	4,1	87,5	41		
M81693-16-42	25	- 16	1"	M 42x2	30	19,5	82,5	5,3	75,5	50		
M81692-20-42	31	- 20	1.1/4"	M 42x2	30	19,1	102	6	90	50		
M81693-20-52	31	- 20	1.1/4"	M 52x2	38	26,1	101	8	86,5	60		

M81692: THRUST-WIRE NUT - M81693: SLIP-ON NUT

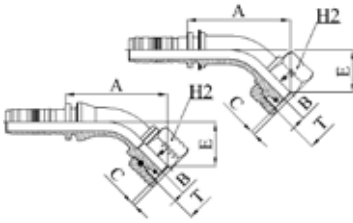

## DIN STANDARD CONNECTIONS

### M81642/M81643

**45° METRIC O-RING FEMALE SWEPT ELBOW 24° CONE HEAVY DUTY  
DIN 20066 / ISO 12151-2**

PART. REF.	HOSE BORE			Thread	Pipe	DIMENSIONS mm						
	DN	Dash	inch			T	mm	B	A	C	E	H2
M81642-12-30	19	- 12	3/4"	M 30x2	20	12,5	80	3,2	35	36		
M81643-12-36	19	- 12	3/4"	M 36x2	25	14,5	82	3,4	33,5	41		
M81642-16-36	25	- 16	1"	M 36x2	25	15	103	4,1	44,5	41		
M81643-16-42	25	- 16	1"	M 42x2	30	19,5	94	5,3	36	50		
M81642-20-42	31	- 20	1.1/4"	M 42x2	30	19,1	117,5	6	44	50		
M81643-20-52	31	- 20	1.1/4"	M 52x2	38	26,1	111	8	40	60		

M81642: THRUST-WIRE NUT - M81643: SLIP-ON NUT

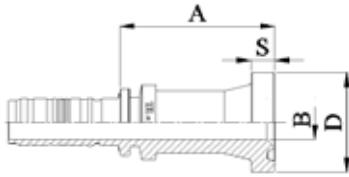

## ORIGINAL EQUIPMENT CONNECTIONS

**M83711**

**FLANGE PLUS (SAE J518 -2 / ISO 6162-2 PORT COMPATIBLE)**

PART. REF.	HOSE BORE			Flange	DIMENSIONS mm						
	DN	Dash	inch		Inch	B	A	D	S		
M83711-12-12	19	- 12	3/4"	3/4"		14,5	65	41,4	10		
M83711-16-16	25	- 16	1"	1"		19,5	65	47,7	11		
M83711-20-20	31	- 20	1.1/4"	1.1/4"		25	81	54,2	12		

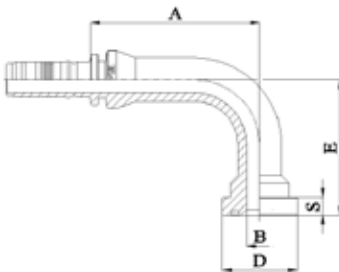

## ORIGINAL EQUIPMENT CONNECTIONS

**M83791**

**90° FLANGE PLUS (SAE J518 -2/ ISO 6162-2 PORT COMPATIBLE)**

PART. REF.	HOSE BORE			Flange	DIMENSIONS mm					
	DN	Dash	inch		Inch	B	A	D	E	S
M83791-12-12	19	- 12	3/4"	3/4"		14,5	93,5	41,4	75	10
M83791-16-16	25	- 16	1"	1"		19,5	91	47,7	90	11
M83791-20-20	31	- 20	1.1/4"	1.1/4"		25	115	54,2	110	12

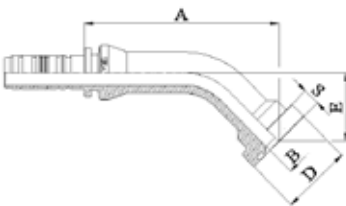

## ORIGINAL EQUIPMENT CONNECTIONS

**M83741**

**45° FLANGE PLUS (SAE J518-2/ISO 6162-2 PORT COMPATIBLE)**

PART. REF.	HOSE BORE			Flange	DIMENSIONS mm					
	DN	Dash	inch		Inch	B	A	D	E	S
M83741-12-12	19	- 12	3/4"	3/4"		14,5	114	41,4	40	10
M83741-16-16	25	- 16	1"	1"		19,5	107,5	47,7	43	11
M83741-20-20	31	- 20	1.1/4"	1.1/4"		25	133,5	54,2	50	12

## ORIGINAL EQUIPMENT CONNECTIONS

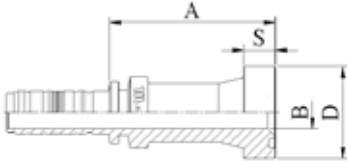

### M83911

#### STRAIGHT SUPERCAT SERIES FLANGE

PART. REF.	HOSE BORE			Flange	DIMENSIONS mm						
	DN	Dash	inch		Inch	B	A	D	S		
M83911-12-12	19	- 12	3/4"	3/4"		14,5	75	41,5	14,3		
M83911-12-16	19	- 12	3/4"	1"		19,5	80,5	47,7	14,3		
M83911-16-16	25	- 16	1"	1"		19,5	80	47,7	14,3		
M83911-16-20	25	- 16	1"	1.1/4"		26	84	54	14,3		
M83911-20-20	31	- 20	1.1/4"	1.1/4"		26	80,5	54	14,3		
M83911-20-24	31	- 20	1.1/4"	1.1/2"		32	84	63,6	14,3		
M83911-24-24	38	- 24	1.1/2"	1.1/2"		32	84,5	63,6	14,3		
M83911-24-32	38	- 24	1.1/2"	2"		42	107,5	79,3	14,3		
M83911-32-24	51	- 32	2"	1.1/2"		32	95,5	63,6	14,3		
M83911-32-32	51	- 32	2"	2"		42	110,5	79,3	14,3		

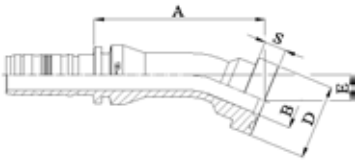

## ORIGINAL EQUIPMENT CONNECTIONS

### M83921

#### 22,5° SUPERCAT SERIES FLANGE

PART. REF.	HOSE BORE			Flange	DIMENSIONS mm						
	DN	Dash	inch		Inch	B	A	D	E	S	
M83921-12-12	19	- 12	3/4"	3/4"		16	101,5	41,5	16	14,3	
M83921-12-16	19	- 12	3/4"	1"		19,5	98	47,7	16,5	14,3	
M83921-16-16	25	- 16	1"	1"		19,5	108,5	47,7	16,5	14,3	
M83921-16-20	25	- 16	1"	1.1/4"		26	113	54	18,5	14,3	
M83921-20-20	31	- 20	1.1/4"	1.1/4"		26	120,5	54	18	14,3	
M83921-20-24	31	- 20	1.1/4"	1.1/2"		32	119	63,7	21	14,3	
M83921-24-24	38	- 24	1.1/2"	1.1/2"		32	123,5	63,7	20	14,3	



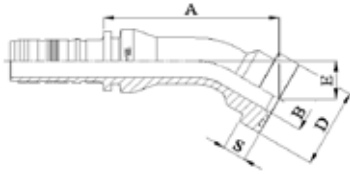

## ORIGINAL EQUIPMENT CONNECTIONS

### M83931

#### 30° SUPERCAT SERIES FLANGE

PART. REF.	HOSE BORE			Flange	DIMENSIONS mm						
	DN	Dash	inch		Inch	B	A	D	E	S	
M83931-12-12	19	- 12	3/4"	3/4"	16	99	41,5	22	14,3		
M83931-12-16	19	- 12	3/4"	1"	19,5	99,5	47,7	22,5	14,3		
M83931-16-16	25	- 16	1"	1"	19,5	106	47,7	23	14,3		
M83931-16-20	25	- 16	1"	1.1/4"	26	110	54	26	14,3		
M83931-20-20	31	- 20	1.1/4"	1.1/4"	26	117,5	54	25	14,3		
M83931-20-24	31	- 20	1.1/4"	1.1/2"	32	115,5	63,7	29	14,3		
M83931-24-24	38	- 24	1.1/2"	1.1/2"	32	120,5	63,7	28	14,3		
M83931-24-32	38	- 24	1.1/2"	2"	42	134,5	79,3	36	14,3		
M83931-32-32	51	- 32	2"	2"	42	163,5	79,3	37,5	14,3		

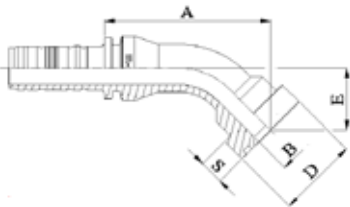

## ORIGINAL EQUIPMENT CONNECTIONS

### M83941

#### 45° SUPERCAT SERIES FLANGE

PART. REF.	HOSE BORE			Flange	DIMENSIONS mm						
	DN	Dash	inch		Inch	B	A	D	E	S	
M83941-12-12	19	- 12	3/4"	3/4"	16	91,5	41,5	34,5	14,3		
M83941-12-16	19	- 12	3/4"	1"	19,5	92	47,7	35,5	14,3		
M83941-16-16	25	- 16	1"	1"	19,5	98	47,7	36,5	14,3		
M83941-16-20	25	- 16	1"	1.1/4"	26	101	54	40,5	14,3		
M83941-20-20	31	- 20	1.1/4"	1.1/4"	26	109	54	40	14,3		
M83941-20-24	31	- 20	1.1/4"	1.1/2"	32	106	63,7	46	14,3		
M83941-24-24	38	- 24	1.1/2"	1.1/2"	32	111	63,7	45,5	14,3		
M83941-24-32	38	- 24	1.1/2"	2"	42	122	79,3	56,5	14,3		
M83941-32-32	51	- 32	2"	2"	42	150,5	79,3	61,5	14,3		

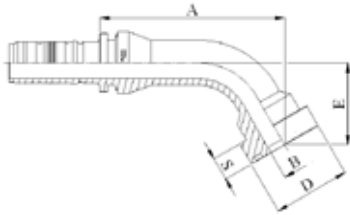

## ORIGINAL EQUIPMENT CONNECTIONS

### M83961

#### 60° SUPERCAT SERIES FLANGE

PART. REF.	HOSE BORE			Flange	DIMENSIONS mm						
	DN	Dash	inch		Inch	B	A	D	E	S	
M83961-12-12	19	- 12	3/4"	3/4"	16	106,5	41,5	47	14,3		
M83961-12-16	19	- 12	3/4"	1"	19,5	107	47,7	48	14,3		
M83961-16-16	25	- 16	1"	1"	19,5	114	47,7	51	14,3		
M83961-16-16055	25	- 16	1"	1"	19,5	100	47,7	55	14,3		
M83961-16-20	25	- 16	1"	1.1/4"	26	116,5	54	54	14,3		
M83961-20-20	31	- 20	1.1/4"	1.1/4"	26	130	54	54,5	14,3		
M83961-20-24	31	- 20	1.1/4"	1.1/2"	32	126	63,7	63,5	14,3		
M83961-24-24	38	- 24	1.1/2"	1.1/2"	32	140	63,7	63	14,3		
M83961-32-32	51	- 32	2"	2"	42	194	79,3	86,5	14,3		
M83961-32-32150	51	- 32	2"	2"	42	198	79,3	150	14,3		

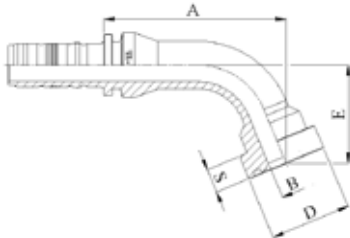

## ORIGINAL EQUIPMENT CONNECTIONS

### M83971

#### 67,5° SUPERCAT SERIES FLANGE

PART. REF.	HOSE BORE			Flange	DIMENSIONS mm						
	DN	Dash	inch		Inch	B	A	D	E	S	
M83971-12-12	19	- 12	3/4"	3/4"	16	100	41,5	53	14,3		
M83971-12-16	19	- 12	3/4"	1"	19,5	100,5	47,7	54	14,3		
M83971-16-16	25	- 16	1"	1"	19,5	107	47,7	58	14,3		
M83971-16-20	25	- 16	1"	1.1/4"	26	109	54	62	14,3		
M83971-20-20	31	- 20	1.1/4"	1.1/4"	26	123	54	62	14,3		
M83971-20-24	31	- 20	1.1/4"	1.1/2"	32	117,5	63,7	71,5	14,3		
M83971-24-24	38	- 24	1.1/2"	1.1/2"	32	131	63,7	72	14,3		
M83971-32-32	51	- 32	2"	2"	42	181,5	79,3	99	14,3		

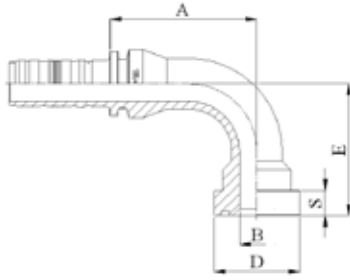

## ORIGINAL EQUIPMENT CONNECTIONS

### M83991

#### 90° SUPERCAT SERIES FLANGE

PART. REF.	HOSE BORE			Flange	DIMENSIONS mm						
	DN	Dash	inch		Inch	B	A	D	E	S	
M83991-12-12	19	- 12	3/4"	3/4"	16	76	41,5	68,5	14,3		
M83991-12-16	19	- 12	3/4"	1"	19,5	76	47,7	69,5	14,3		
M83991-16-16	25	- 16	1"	1"	19,5	82	47,7	73,5	14,3		
M83991-16-20	25	- 16	1"	1.1/4"	26	82	54	78,5	14,3		
M83991-20-20	31	- 20	1.1/4"	1.1/4"	26	94	54	82	14,3		
M83991-20-24	31	- 20	1.1/4"	1.1/2"	32	85	63,7	92	14,3		
M83991-24-24	38	- 24	1.1/2"	1.1/2"	32	98	63,7	96	14,3		
M83991-24-32	38	- 24	1.1/2"	2"	42	98	79,3	112	14,3		
M83991-32-32	51	- 32	2"	2"	42	136	79,3	133,5	14,3		

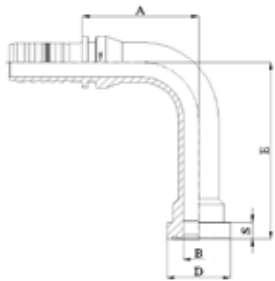

## ORIGINAL EQUIPMENT CONNECTIONS

### M83991 LONG DROP

#### 90° LONG DROP SUPERCAT SERIES FLANGE

PART. REF.	HOSE BORE			Flange	DIMENSIONS mm						
	DN	Dash	inch		Inch	B	A	D	E	S	
M83991-16-16132	25	- 16	1"	1"	19,5	86	47,7	132	14,3		
M83991-16-16150	25	- 16	1"	1"	19,5	86	47,7	150	14,3		
M83991-16-20150	25	- 16	1"	1.1/4"	26	82	54	150	14,3		
M83991-20-20092	31	- 20	1.1/4"	1.1/4"	26,1	99	54	92	14,3		
M83991-20-20150	31	- 20	1.1/4"	1.1/4"	26,1	99	54	150	14,3		
M83991-20-24135	31	- 20	1.1/4"	1.1/2"	32	98,5	63,7	135	14,3		
M83991-24-24106	38	- 24	1.1/2"	1.1/2"	32	112,5	63,7	106	14,3		

## XTRAFLANGE

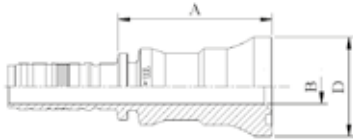

### M88511

XTRAFLANGE/62 (SAE J518 -2/ ISO 6162-2 PORT COMPATIBLE)

FITTINGS

F 6-24

PART. REF.	HOSE BORE			Flange		DIMENSIONS mm						
	DN	Dash	inch			Inch	B	A	D			
M88511-12-12	19	- 12	3/4"	3/4"		14,5	65,5	41,4				
M88511-16-16	25	- 16	1"	1"		19,5	69	47,7				
M88511-20-20	31	- 20	1.1/4"	1.1/4"		25	88	54,4				
M88511-24-24	38	- 24	1.1/2"	1.1/2"		30,5	102	63,7				
M88511-32-32	51	- 32	2"	2"		41	129,5	79,6				

## XTRAFLANGE

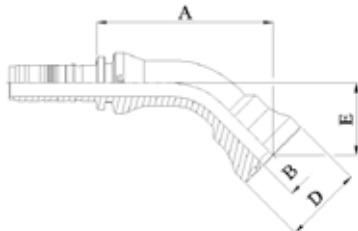

### M88541

45° XTRAFLANGE/62 (SAE J518 -2/ ISO 6162-2 PORT COMPATIBLE)

PART. REF.	HOSE BORE			Flange		DIMENSIONS mm						
	DN	Dash	inch			Inch	B	A	D	E		
M88541-12-12	19	- 12	3/4"	3/4"		14,5	93,5	41,4	38			
M88541-16-16	25	- 16	1"	1"		19,5	103,5	47,7	45			
M88541-20-20	31	- 20	1.1/4"	1.1/4"		25	138	54,4	62,5			
M88541-24-24	38	- 24	1.1/2"	1.1/2"		30,5	155	63,7	71,5			
M88541-32-32	51	- 32	2"	2"		39	194,5	79,6	92,5			

## XTRAFLANGE

### M88591

90° XTRAFLANGE/62 (SAE J518 -2/ ISO 6162-2 PORT COMPATIBLE)

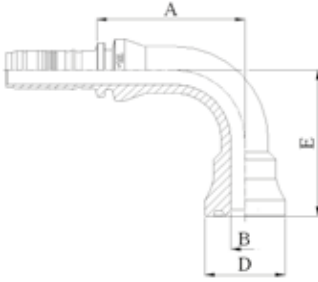

PART. REF.	HOSE BORE			Flange	DIMENSIONS mm							
	DN	Dash	inch		B	A	D	E				
M88591-12-12	19	- 12	3/4"	3/4"	14,5	76,5	41,4	75				
M88591-16-16	25	- 16	1"	1"	19,5	84,5	47,7	90				
M88591-20-20	31	- 20	1.1/4"	1.1/4"	25	107	54,4	120				
M88591-24-24	38	- 24	1.1/2"	1.1/2"	30,5	122	63,7	140				
M88591-32-32	51	- 32	2"	2"	39	148,5	79,6	178				

## TAIL

### M89510WL

WELDING TAIL

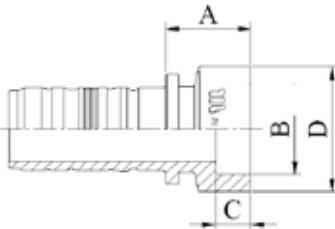

PART. REF.	HOSE BORE			DIMENSIONS mm						
	DN	Dash	inch	B	A	C	D			
M89510-12-22WL	19	- 12	3/4"	22,1	28,5	12	34			
M89510-16-28WL	25	- 16	1"	28,1	32,5	14	40			
M89510-20-35WL	31	- 20	1.1/4"	35,1	33	14	49			

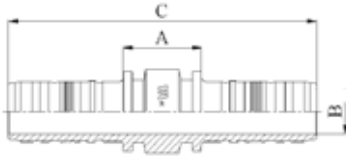

## DOUBLE CONNECTOR

**M70050**

DOUBLE CONNECTOR

PART. REF.	HOSE BORE			DIMENSIONS mm								
	DN	Dash	inch			B	A	C				
M70050-20-20	31	- 20	1.1/4"			25	42,5	166,2				
M70050-24-24	38	- 24	1.1/2"			30,5	43	178,9				
M70050-32-32	51	- 32	2"			41	45,5	220,8				

**FITTINGS**  
 F 6-26



**PUSHLOCK**





FITTING CODE	SECTION	PAGE
L10510	7	1
L20513	7	1
L20543	7	2
L20593	7	2

## PUSHLOCK

<b>DN</b>	5	6	8	10	12	16	19	25	31	38	51	60	63	76	89	102
<b>Inch</b>	3/16"	1/4"	5/16"	3/8"	1/2"	5/8"	3/4"	1"	1 1/4"	1 1/2"	2"	2 3/8"	2 1/2"	3"	3 1/2"	4"
<b>Size</b>	-03	-04	-05	-06	-08	-10	-12	-16	-20	-24	-32	-38	-40	-48	-56	-64

## FITTINGS

BSP																	
-----	--	--	--	--	--	--	--	--	--	--	--	--	--	--	--	--	--

## BS STANDARD CONNECTIONS

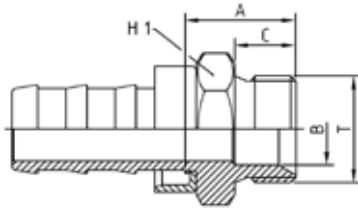

### L10510

**BSP MALE PARALLEL 60° CONE SEAT - BS5200/ISO 8434-6**

PART. REF.	HOSE BORE			Thread		DIMENSIONS mm						
	DN	Dash	inch			T	B	A	C			
L10510-04-04	6	-4	1/4"	1/4" - 19		5	20,5	11	19			
L10510-04-06	6	-4	1/4"	3/8" - 19		8	22,5	12	22			
L10510-06-06	10	-6	3/8"	3/8" - 19		8	23	12	22			
L10510-08-08	12	-8	1/2"	1/2" - 14		11	27	14	27			
L10510-10-10	16	-10	5/8"	5/8" - 14		14,5	28,5	16	30			
L10510-12-12	19	-12	3/4"	3/4" - 14		17	30,5	16	32			
L10510-16-16	25	-16	1"	1" - 11		22,5	34,5	19	41			

No ferrule needed

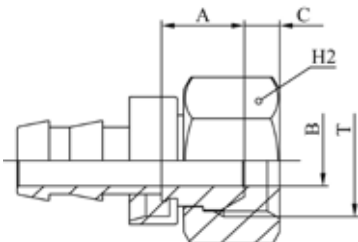

## BS STANDARD CONNECTIONS

### L20513

**BSP FEMALE 60° CONE - BS5200/ISO 12151-6 (SLIP-ON NUT)**

PART. REF.	HOSE BORE			Thread		DIMENSIONS mm						
	DN	Dash	inch			T	B	A	C			
L20513-04-04	6	-4	1/4"	1/4" - 19		4	12,5	5,8	19			
L20513-04-06	6	-4	1/4"	3/8" - 19		7	14,6	6,2	22			
L20513-06-06	10	-6	3/8"	3/8" - 19		7	15	6,2	22			
L20513-08-08	12	-8	1/2"	1/2" - 14		9,5	16,5	6,5	27			
L20513-10-10	16	-10	5/8"	5/8" - 14		12	16	9	28			
L20513-12-12	19	-12	3/4"	3/4" - 14		16	18	9	32			
L20513-12-16	19	-12	3/4"	1" - 11		19	19,5	11	38			
L20513-16-16	25	-16	1"	1" - 11		19	19,5	11	38			

No ferrule needed

## BS STANDARD CONNECTIONS

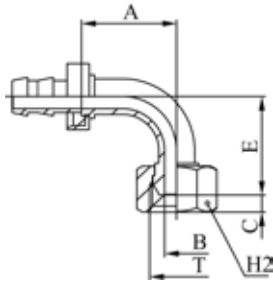

### L20593

**90° BSP FEMALE SWEPT ELBOW 60° CONE - BS5200/ISO 12151-6 (SLIP-ON NUT)**

PART. REF.	HOSE BORE			Thread		DIMENSIONS mm						
	DN	Dash	inch			T	B	A	C	E	H2	
L20593-04-04	6	-4	1/4"	1/4" - 19		4	26	5,8	24	19		
L20593-06-06	10	-6	3/8"	3/8" - 19		7	35	6,2	30,5	22		
L20593-08-08	12	-8	1/2"	1/2" - 14		9,5	38	6,5	38,5	27		
L20593-10-10	16	-10	5/8"	5/8" - 14		12	45,5	9	41	28		
L20593-12-12	19	-12	3/4"	3/4" - 14		16	48,5	9	46,5	32		
L20593-12-16	19	-12	3/4"	1" - 11		19	48,5	11	48,5	38		
L20593-16-16	25	-16	1"	1" - 11		19	54	11	54	38		

No ferrule needed

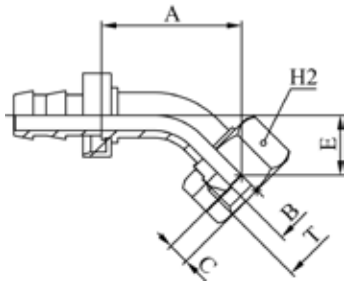

## BS STANDARD CONNECTIONS

### L20543

**45° BSP FEMALE SWEPT ELBOW 60° CONE - BS5200/ISO 12151-6 (SLIP-ON NUT)**

PART. REF.	HOSE BORE			Thread		DIMENSIONS mm						
	DN	Dash	inch			T	B	A	C	E	H2	
L20543-04-04	6	-4	1/4"	1/4" - 19		4	31	5,8	12	19		
L20543-06-06	10	-6	3/8"	3/8" - 19		7	38,5	6,2	14,5	22		
L20543-08-08	12	-8	1/2"	1/2" - 14		9,5	44	6,5	18,5	27		
L20543-10-10	16	-10	5/8"	5/8" - 14		12	50,5	9	19	28		
L20543-12-12	19	-12	3/4"	3/4" - 14		16	53	9	21	32		
L20543-16-16	25	-16	1"	1" - 11		19	56	11	23,5	38		

No ferrule needed



# ACCESSORIES



FITTING CODE	SECTION	PAGE
O820	8	1
O83308	8	2
O83607	8	3
O83609	8	2
O88507	8	3
O88407	8	4





## ACCESSORIES

### O820

#### ANTI-KINK SLEEVE

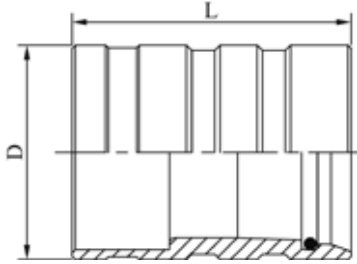

PART. REF.	HOSE BORE			DIMENSIONS mm							
	DN	Dash	inch			D	L				
O82040-12	19	- 12	3/4"			45	67				
O82040-16	25	- 16	1"			52	81				
O82068-16	25	- 16	1"			55	75				
O82062-20	31	- 20	1.1/4"			64	83				
O82060-20	31	- 20	1.1/4"			64	84				
O82068-20	31	- 20	1.1/4"			65,5	83				
O82068-24	38	- 24	1.1/2"			73	99				
O82060-24	38	- 24	1.1/2"			72	102				
O82068-32	51	- 32	2"			86,5	116				
O82068-40	63	- 40	2.1/2"			100,5	148,5				
O82068-48	76	- 48	3"			112	158				

## ACCESSORIES

### 083308

ISO/SAE CODE 61 SPLIT FLANGE CLAMPS - SAE J518 / ISO 6162-1

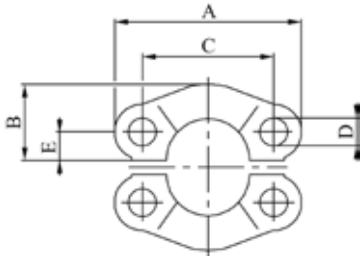

PART. REF.	HOSE BORE			DIMENSIONS mm							
	DN	Dash	inch	B	A	C	D	E			
O83308-08				22,8	54	38,1	8,8	8,7			
O83308-12				25,9	65	47,6	10,8	11,1			
O83308-16				29,2	70	52,4	10,8	13,1			
O83308-20				36,3	79	58,7	12	15,1			
O83308-24				41,1	94	69,8	13,5	17,9			
O83308-32				48,2	102	77,8	13,5	21,4			
O83308-40				54,1	114	88,9	13,5	25,4			
O83308-48				65,3	135	106,4	16,8	31			
O83308-56				70	152	120,6	17	34,8			
O83308-64				75	160	130,2	17	38,9			

## ACCESSORIES

### 083609

ISO/SAE CODE 62 SPLIT FLANGE CLAMPS - SAE J518 / ISO 6162-2

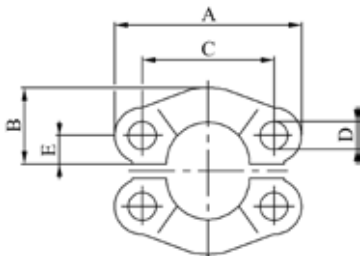

PART. REF.	HOSE BORE			DIMENSIONS mm							
	DN	Dash	inch	B	A	C	D	E			
O83609-08				23,6	56	40,5	8,8	9,1			
O83609-12				30	71	50,8	11	11,9			
O83609-16				34,8	81	57,1	13	13,9			
O83609-20				38,6	95	66,7	15	15,9			
O83609-24				47,5	113	79,4	17	18,3			
O83609-32				56,9	133	96,8	21	22,2			

## ACCESSORIES

### O83607

ONE-PIECE FLANGE CLAMP ISO 6162-2 / SAE J518 CODE 62

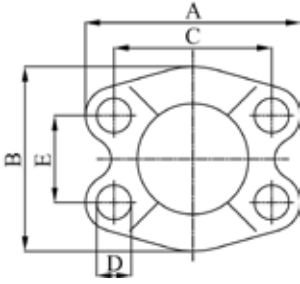

PART. REF.	HOSE BORE			DIMENSIONS mm							
	DN	Dash	inch	B	A	C	D	E			
O83607-12	19	- 12	3/4"	60	72	50,8	10,5	23,8			
O83607-16	25	- 16	1"	70	81	57,2	13	27,8			
O83607-20	31	- 20	1.1/4"	78	96	66,7	15	31,8			
O83607-24	38	- 24	1.1/2"	96	113	79,4	17	36,5			
O83607-32	51	- 32	2"	114	134	96,8	21	44,4			
O83607-40	63	- 40	2.1/2"	150	175	123,8	25	58,7			
O83607-48	76	- 48	3"	178	210	152,4	32	71,4			

## ACCESSORIES

### O88507

ONE-PIECE XTRAFRANGE CLAMP ISO 6162-2 / SAE J518 CODE 62  
PORT COMPATIBLE

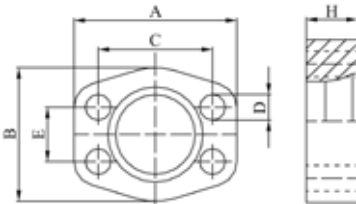

PART. REF.	HOSE BORE			DIMENSIONS mm							
	DN	Dash	inch	B	A	C	D	E	H		
O88507-12				60	71,5	50,8	11	23,8	21,5		
O88507-16				66,7	80	57,2	13	27,8	24		
O88507-20				78	95	66,7	15	31,7	30		
O88507-24				94	112	79,4	17	36,5	36		
O88507-32				114	133	96,8	21	44,5	47		
O88507-40				150	180	123,8	26	58,8	55		
O88507-48				176	210,3	152,4	31	71,4	60		

## ACCESSORIES

### O88407

ONE-PIECE XTRAFANGE 61 CLAMP/SPLIT XTRAFANGE/61 CLAMP

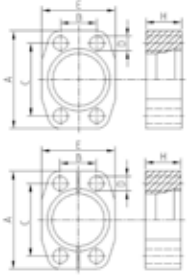

PART. REF.	HOSE BORE			Flange	DIMENSIONS mm							
	DN	Dash	inch		Inch	B	A	C	D	E	H	
O88407-16				1"		26,2	70,5	52,4	10,6	53	25,7	
O88407-20				1.1/4"		30,2	80	58,7	12	64	26,8	
O88407-24				1.1/2"		35,7	94	69,9	13,3	77	33,6	
O88407-32				2"		42,9	102	77,8	13,3	88	35	
O88407-40				2.1/2"		50,8	114	88,9	13,3	102	44,3	

O88407-32 and O88407-40 : SPLIT XTRAFANGE/61 CLAMP



**OPF**



FITTING CODE	SECTION	PAGE
OPF10510	9	2
OPF10710	9	2
OPF11110	9	30
OPF11210	9	34
OPF12410	9	16
OPF12510	9	9
OPF12810	9	23
OPF13010	9	21
OPF14110R	9	24
OPF14310	9	22
OPF14390	9	22
OPF20512-OPF20513	9	3
OPF20542-OPF20543	9	5
OPF20592-OPF20593	9	4
OPF20612-OPF20613	9	8
OPF20711	9	38
OPF20812-OPF20813	9	6
OPF20842-OPF20843	9	7
OPF20882F	9	7
OPF20892-OPF20893	9	6
OPF21312-OPF21313	9	29
OPF21392-OPF21393	9	29
OPF21512-OPF21513	9	31
OPF21542-OPF21543	9	33
OPF21592-OPF21593	9	32
OPF21612-OPF21613	9	35
OPF21642-OPF21643	9	37
OPF21692-OPF21693	9	36
OPF22010	9	28

FITTING CODE	SECTION	PAGE
OPF22411	9	17
OPF22441-OPF22443	9	20
OPF22491-OPF22493	9	18
OPF22541KR	9	15
OPF22542-OPF22543	9	14
OPF22582F	9	16
OPF22591KR	9	12
OPF22592-OPF22593	9	11
OPF22612	9	23
OPF22711-KR-K	9	10
OPF22712	9	9
OPF22812	9	24
OPF23311	9	25
OPF23321	9	25
OPF23331	9	26
OPF23341	9	26
OPF23361	9	27
OPF23371	9	27
OPF23391	9	28
OPF23811	9	38
OPF24011	9	37
OPF24111	9	39
OPF24141	9	39
OPF24191	9	39
OPF24491 LONG DROP	9	19
OPF24791KR	9	13
OPF24792-OPF24793 LONG DROP	9	12
OPF3100	9	1

## OPF

DN	5	6	8	10	12	16	19	25	31	38	51
Inch	$\frac{3}{16}$ "	$\frac{1}{4}$ "	$\frac{5}{16}$ "	$\frac{3}{8}$ "	$\frac{1}{2}$ "	$\frac{5}{8}$ "	$\frac{3}{4}$ "	1"	$1\frac{1}{4}$ "	$1\frac{1}{2}$ "	2"
Size	-03	-04	-05	-06	-08	-10	-12	-16	-20	-24	-32

## FERRULES

OPF3100											
---------	--	--	--	--	--	--	--	--	--	--	--

## FITTINGS

BSP											
SAE (JIC)											
SAE (ORFS)											
SAE (O-RING BOSS)											
SAE (NPTF-NPSM)											
SAE FLANGE CODE 61											
DIN STANDPIPE											
DIN METRIC MULTISEAL											
DIN METRIC 24° CONE LIGHT TYPE											
DIN METRIC 24° CONE HEAVY TYPE											
JIS											
ORIGINAL EQUIPMENT CONNECTIONS											





## BS STANDARD CONNECTIONS

### OPF10710

BSP MALE TAPERED

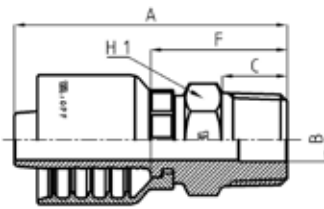

PART. REF.	HOSE BORE			Thread		DIMENSIONS mm						
	DN	Dash	inch			T	B	A	C	F		
OPF10710-08A08	12	- 8	1/2"	1/2" - 14		10	62	15	31	22		
OPF10710-10A12	16	- 10	5/8"	3/4" - 14		17	68,5	17	34	27		

## BS STANDARD CONNECTIONS

### OPF10510

BSP MALE PARALLEL 60° CONE SEAT - BS5200 / ISO 8434-6

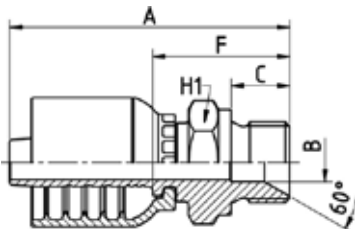

PART. REF.	HOSE BORE			Thread		DIMENSIONS mm						
	DN	Dash	inch			T	B	A	C	F		
OPF10510-03A02	5	- 3	3/16"	1/8" - 28		3,5	44	10	22,5	14		
OPF10510-04A02	6	- 4	1/4"	1/8" - 28		3,5	50	10	22,5	14		
OPF10510-04A04	6	- 4	1/4"	1/4" - 19		5	53	11	25,5	19		
OPF10510-04A06	6	- 4	1/4"	3/8" - 19		8	54,5	12	27	22		
OPF10510-05A04	8	- 5	5/16"	1/4" - 19		5	54	11	26	19		
OPF10510-05A06	8	- 5	5/16"	3/8" - 19		8	55,5	12	27,5	22		
OPF10510-06A04	10	- 6	3/8"	1/4" - 19		5	55,5	11	26	19		
OPF10510-06A06	10	- 6	3/8"	3/8" - 19		8	57,5	12	28	22		
OPF10510-06A08	10	- 6	3/8"	1/2" - 14		11	60	14	30,5	27		
OPF10510-08A06	12	- 8	1/2"	3/8" - 19		8	59	12	28	22		
OPF10510-08A08	12	- 8	1/2"	1/2" - 14		11	62	14	31	27		
OPF10510-08A10	12	- 8	1/2"	5/8" - 14		14,5	64	16	33	30		
OPF10510-08A12	12	- 8	1/2"	3/4" - 14		17	65	16	34	32		
OPF10510-10A10	16	- 10	5/8"	5/8" - 14		14,5	67,5	16	33	30		
OPF10510-10A12	16	- 10	5/8"	3/4" - 14		17	68,5	16	34	32		
OPF10510-12A12	19	- 12	3/4"	3/4" - 14		17	72	16	35,5	32		
OPF10510-12A16	19	- 12	3/4"	1" - 11		22,5	76	19	39,5	41		
OPF10510-16A16	25	- 16	1"	1" - 11		22,5	89	19	41	41		
OPF10510-16A20	25	- 16	1"	1.1/4" - 11		28,5	93	20	45	50		

## BS STANDARD CONNECTIONS

### OPF20512/OPF20513

BSP FEMALE 60° CONE - BS5200 / ISO 12151-6

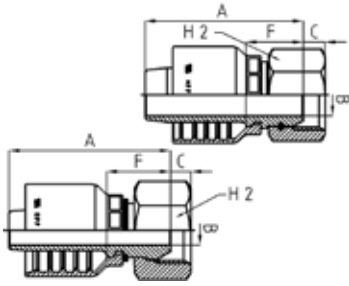

PART. REF.	HOSE BORE			Thread		DIMENSIONS mm						
	DN	Dash	inch			T	B	A	C	F	H2	
OPF20512-03A02	5	- 3	3/16"	1/8" - 28		3	37	4,4	16	14		
OPF20513-03A04	5	- 3	3/16"	1/4" - 19		4	38	5,4	16,5	19		
OPF20512-04A02	6	- 4	1/4"	1/8" - 28		3,1	44	4,4	16,5	14		
OPF20513-04A04	6	- 4	1/4"	1/4" - 19		4	44,5	5,4	17	19		
OPF20513-04A06	6	- 4	1/4"	3/8" - 19		7	45,5	6	19	22		
OPF20512-05A04	8	- 5	5/16"	1/4" - 19		4,1	45,5	4,2	17,5	19		
OPF20513-05A06	8	- 5	5/16"	3/8" - 19		7	47	6	19	22		
OPF20512-06A04	10	- 6	3/8"	1/4" - 19		4,1	47,5	4,2	18	19		
OPF20513-06A06	10	- 6	3/8"	3/8" - 19		7	49	6	19,5	22		
OPF20513-06A08	10	- 6	3/8"	1/2" - 14		9,3	49,5	6,3	20	27		
OPF20512-08A06	12	- 8	1/2"	3/8" - 19		7,1	52	6	21	22		
OPF20513-08A08	12	- 8	1/2"	1/2" - 14		9,3	51,5	6,3	20,5	27		
OPF20512-08A10	12	- 8	1/2"	5/8" - 14		12,1	53	10,2	22	28		
OPF20512-08A12	12	- 8	1/2"	3/4" - 14		15	56	9	24,5	32		
OPF20512-10A10	16	- 10	5/8"	5/8" - 14		12,5	56	10,2	21,5	28		
OPF20512-10A12	16	- 10	5/8"	3/4" - 14		15	57,5	9	23	32		
OPF20512-12A12	19	- 12	3/4"	3/4" - 14		15	61	9	24,5	32		
OPF20512-12A16	19	- 12	3/4"	1" - 11		19,8	62,5	10,5	26	38		
OPF20512-16A16	25	- 16	1"	1" - 11		19,8	75,5	10,5	27,5	38		

OPF20512: THRUST-WIRE NUT / OPF20513: SLIP-ON NUT

## BS STANDARD CONNECTIONS

### OPF20592/OPF20593

90° BSP FEMALE ELBOW 60° CONE - BS5200 / ISO 12151-6

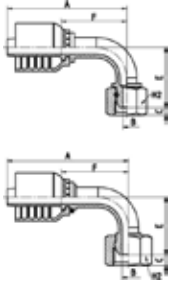

PART. REF.	HOSE BORE			Thread	DIMENSIONS mm							
	DN	Dash	inch		T	B	A	C	E	F	H2	
OPF20592-03A02	5	- 3	3/16"	1/8" - 28		3	43	4,4	26	21,5	14	
OPF20592-04A02	6	- 4	1/4"	1/8" - 28		3,1	56	4,4	27	28,5	14	
OPF20593-04A04	6	- 4	1/4"	1/4" - 19		4	57	5,4	29	29,5	19	
OPF20593-04A06	6	- 4	1/4"	3/8" - 19		7	57	6	31	29,5	22	
OPF20592-05A04	8	- 5	5/16"	1/4" - 19		4	54,5	4,1	29,5	26,5	19	
OPF20593-05A06	8	- 5	5/16"	3/8" - 19		7	60	6	27,5	32	22	
OPF20593-06A06	10	- 6	3/8"	3/8" - 19		7	66	6	31,5	36,5	22	
OPF20593-06A08	10	- 6	3/8"	1/2" - 14		9,3	66	6,3	32	36,5	27	
OPF20592-08A06	12	- 8	1/2"	3/8" - 19		7,1	76	6	41	45	22	
OPF20593-08A08	12	- 8	1/2"	1/2" - 14		9,3	76	6,3	36,5	45	27	
OPF20592-08A10	12	- 8	1/2"	5/8" - 14		12,1	75,5	10,2	44	44	28	
OPF20592-08A12	12	- 8	1/2"	3/4" - 14		15	75,5	9	45,5	44	32	
OPF20592-10A10	16	- 10	5/8"	5/8" - 14		12,5	88	10,2	53,5	53,5	28	
OPF20592-10A12	16	- 10	5/8"	3/4" - 14		15	88	9	55	53,5	32	
OPF20592-12A12	19	- 12	3/4"	3/4" - 14		15	98	9	59,5	61,5	32	
OPF20592-12A16	19	- 12	3/4"	1" - 11		19,8	98	10,5	62	61,5	38	
OPF20592-16A16	25	- 16	1"	1" - 11		19,8	127,5	10,5	76	79,5	38	

OPF20592: THRUST-WIRE NUT / OPF20593: SLIP-ON NUT

## BS STANDARD CONNECTIONS

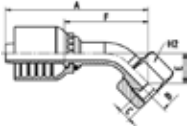
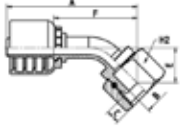

### OPF20542/OPF20543

45° BSP FEMALE ELBOW 60° CONE - BS5200 / ISO 12151-6

PART. REF.	HOSE BORE			Thread		DIMENSIONS mm						
	DN	Dash	inch			T	B	A	C	E	F	H2
OPF20543-04A04	6	- 4	1/4"	1/4" - 19		4	63,5	5,4	15	36	19	
OPF20543-04A06	6	- 4	1/4"	3/8" - 19		7	65	6	16	37,5	22	
OPF20543-05A06	8	- 5	5/16"	3/8" - 19		7	66	6	13,5	38	22	
OPF20543-06A06	10	- 6	3/8"	3/8" - 19		7	71,5	6	15,5	42	22	
OPF20543-06A08	10	- 6	3/8"	1/2" - 14		9,3	72	6,3	16	42,5	27	
OPF20543-08A08	12	- 8	1/2"	1/2" - 14		9,3	81	6,3	17	49,5	27	
OPF20542-08A10	12	- 8	1/2"	5/8" - 14		12,1	85,5	10,2	22,5	54,5	28	
OPF20542-10A10	16	- 10	5/8"	5/8" - 14		12,5	97,5	10,2	26	63	28	
OPF20542-10A12	16	- 10	5/8"	3/4" - 14		15	98	9	27	64	32	
OPF20542-12A12	19	- 12	3/4"	3/4" - 14		15	107	9	28,5	70,5	32	
OPF20542-12A16	19	- 12	3/4"	1" - 11		19,8	109	10,5	30	72,5	38	
OPF20542-16A16	25	- 16	1"	1" - 11		19,8	139,5	10,5	36,5	91	38	

OPF20542: THRUST-WIRE NUT / OPF20543: SLIP-ON NUT

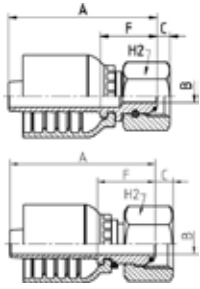

## BS STANDARD CONNECTIONS

### OPF20812/OPF20813

BSP O-RING FEMALE 60° CONE - BS5200 / ISO 12151-6

PART. REF.	HOSE BORE			Thread		DIMENSIONS mm						
	DN	Dash	inch			T	B	A	C	F	H2	
OPF20813-04A04	6	-4	1/4"	1/4" - 19		4	44,5	5,4	17	19		
OPF20812-06A04	10	-6	3/8"	1/4" - 19		4,1	47,5	4,1	18	19		
OPF20813-06A06	10	-6	3/8"	3/8" - 19		7	49	6	19,5	22		
OPF20813-08A08	12	-8	1/2"	1/2" - 14		9,3	51,5	6,3	20,5	27		
OPF20812-10A10	16	-10	5/8"	5/8" - 14		12,5	56,5	9,7	22	28		
OPF20812-12A12	19	-12	3/4"	3/4" - 14		15	61,5	8,5	25	32		
OPF20812-16A16	25	-16	1"	1" - 11		19,8	75,5	10,6	27,5	38		
OPF20812-16A20	25	-16	1"	1.1/4" - 11		26,1	79	10,5	31	50		

OPF20812: THRUST-WIRE NUT / OPF20813: SLIP-ON NUT

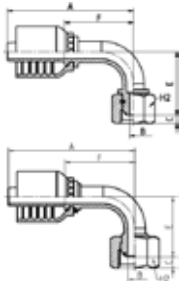

## BS STANDARD CONNECTIONS

### OPF20892/OPF20893

90° BSP O-RING FEMALE SWEEP ELBOW 60° CONE - BS5200 / ISO 12151-6

PART. REF.	HOSE BORE			Thread		DIMENSIONS mm						
	DN	Dash	inch			T	B	A	C	E	F	H2
OPF20893-04A04	6	-4	1/4"	1/4" - 19		4	57	5,4	29	29,5	19	
OPF20892-06A04	10	-6	3/8"	1/4" - 19		4,1	65	4,1	33	35,5	19	
OPF20893-06A06	10	-6	3/8"	3/8" - 19		7	66	6	31,5	36,5	22	
OPF20893-08A08	12	-8	1/2"	1/2" - 14		9,3	76	6,3	36,5	45	27	
OPF20892-10A10	16	-10	5/8"	5/8" - 14		12,5	87,5	9,7	55	53	28	
OPF20892-12A12	19	-12	3/4"	3/4" - 14		15	98	8,5	60	61,5	32	
OPF20892-16A16	25	-16	1"	1" - 11		19,8	127,5	10,6	76	79,5	38	
OPF20892-16A20	25	-16	1"	1.1/4" - 11		26,1	127,5	10,5	78,5	79,5	50	

OPF20892: THRUST-WIRE NUT / OPF20893: SLIP-ON NUT

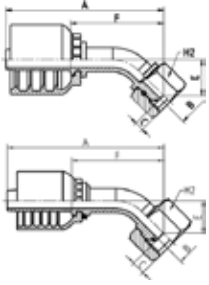

## BS STANDARD CONNECTIONS

### OPF20842/OPF20843

45° BSP O-RING FEMALE ELBOW 60° CONE BS5200 / ISO 12151-6

PART. REF.	HOSE BORE			Thread		DIMENSIONS mm						
	DN	Dash	inch			T	B	A	C	E	F	H2
OPF20843-04A04	6	-4	1/4"	1/4" - 19		4	63,5	5,4	14,5	36	19	
OPF20843-06A06	10	-6	3/8"	3/8" - 19		7	71,5	6	15,5	42	22	
OPF20843-08A08	12	-8	1/2"	1/2" - 14		9,3	81	6,3	17	49,5	27	
OPF20842-10A10	16	-10	5/8"	5/8" - 14		12,5	98	9,7	27,5	63,5	28	
OPF20842-12A12	19	-12	3/4"	3/4" - 14		15	107,5	8,5	29	71	32	
OPF20842-16A16	25	-16	1"	1" - 11		19,8	138,5	10,6	35,5	90,5	38	

OPF20842: THRUST-WIRE NUT / OPF20843: SLIP-ON NUT

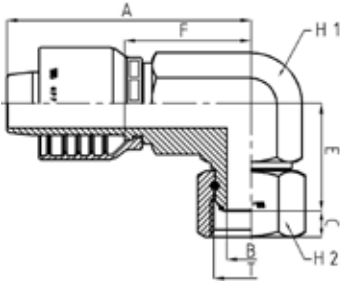

## BS STANDARD CONNECTIONS

### OPF20882F

90° BSP O-RING FEMALE COMPACT ELBOW 60° CONE BS5200 / ISO 12151-6 (THRUST-WIRE NUT)

PART. REF.	HOSE BORE			Thread		DIMENSIONS mm						
	DN	Dash	inch			T	B	A	C	E	F	H1
OPF20882-04A04F	6	-4	1/4"	1/4" - 19		4	47,5	4,1	22	20	14	19
OPF20882-06A06F	10	-6	3/8"	3/8" - 19		7	52,5	6	27,5	23	19	22
OPF20882-08A08F	12	-8	1/2"	1/2" - 14		9,3	56	6,5	31	25	22	27
OPF20882-10A10F	16	-10	5/8"	5/8" - 14		12,5	59	9,7	32,5	24,5	24	28
OPF20882-12A12F	19	-12	3/4"	3/4" - 14		15	74	8,5	36	37,5	27	32
OPF20882-16A16F	25	-16	1"	1" - 11		20	100	10,6	44	52	36	38

## BS STANDARD CONNECTIONS

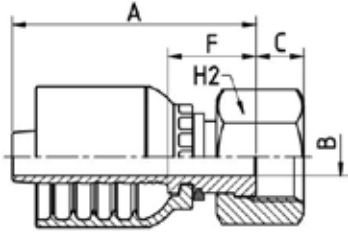

### OPF20612/OPF20613

BSP FEMALE FLAT SEAT (SLIP-ON NUT)

PART. REF.	HOSE BORE			Thread		DIMENSIONS mm						
	DN	Dash	inch			T	B	A	C	F	H2	
OPF20613-04A04	6	-4	1/4"	1/4" - 19		4	42	7,9	14,5	19		
OPF20613-06A06	10	-6	3/8"	3/8" - 19		7	46	9	16,5	22		
OPF20613-06A08	10	-6	3/8"	1/2" - 14		9,3	47	9,8	17,5	27		
OPF20612-08A12	12	-8	1/2"	3/4" - 14		15	52	11,5	21	32		



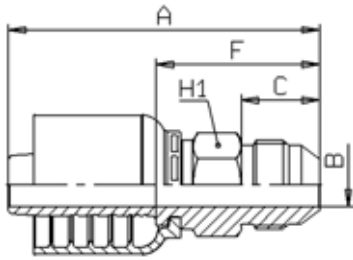

## SAE STANDARD CONNECTIONS

### OPF12510

JIC MALE 37° CONE - SAE J516 / ISO 12151-5

PART. REF.	HOSE BORE			Thread	DIMENSIONS mm							
	DN	Dash	inch		T	B	A	C	F	H1		
OPF12510-04A04	6	-4	1/4"	7/16" - 20		4	55,5	14	28	12		
OPF12510-04A05	6	-4	1/4"	1/2" - 20		5,5	56,5	14	29	14		
OPF12510-04A06	6	-4	1/4"	9/16" - 18		7	56,5	14	29	17		
OPF12510-05A05	8	-5	5/16"	1/2" - 20		5,5	57	14	29	14		
OPF12510-05A06	8	-5	5/16"	9/16" - 18		7	57	14	29	17		
OPF12510-06A06	10	-6	3/8"	9/16" - 18		7	59	14	29,5	17		
OPF12510-06A08	10	-6	3/8"	3/4" - 16		9,3	63,5	16,5	34	19		
OPF12510-06A10	10	-6	3/8"	7/8" - 14		12,5	68	19,5	38,5	24		
OPF12510-08A06	12	-8	1/2"	9/16" - 18		7	63	14	32	19		
OPF12510-08A08	12	-8	1/2"	3/4" - 16		9,3	65,5	16,5	34,5	19		
OPF12510-08A10	12	-8	1/2"	7/8" - 14		12,5	70	19,5	39	24		
OPF12510-08A12	12	-8	1/2"	1.1/16" - 12		15	74	22	43	27		
OPF12510-10A10	16	-10	5/8"	7/8" - 14		12,5	73,5	19,5	39	24		
OPF12510-10A12	16	-10	5/8"	1.1/16" - 12		15	77	22	42,5	27		
OPF12510-12A10	19	-12	3/4"	7/8" - 14		12,5	78	19,5	41,5	27		
OPF12510-12A12	19	-12	3/4"	1.1/16" - 12		15	80,5	22	44	27		
OPF12510-12A14	19	-12	3/4"	1.3/16" - 12		15	81	22,5	44,5	32		
OPF12510-12A16	19	-12	3/4"	1.5/16" - 12		19,8	83,5	23	47	34		
OPF12510-16A12	25	-16	1"	1.1/16" - 12		15	93	22	45	32		
OPF12510-16A16	25	-16	1"	1.5/16" - 12		19,8	96	23	48	34		
OPF12510-16A20	25	-16	1"	1.5/8" - 12		26	101	24,3	53	42		

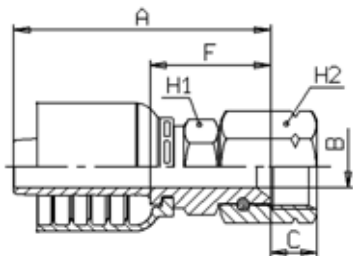

## SAE STANDARD CONNECTIONS

### OPF22712

JIC FEMALE 37° CONE SEAT DOUBLE HEXAGON SAE J516 / ISO 12151-5 (THRUST-WIRE NUT)

PART. REF.	HOSE BORE			Thread	DIMENSIONS mm							
	DN	Dash	inch		T	B	A	C	F	H1	H2	
OPF22712-12A14	19	-12	3/4"	1.3/16" - 12		15	69,5	14,3	33	30	36	
OPF22712-16A20	25	-16	1"	1.5/8" - 12		26	91	16,2	43	41	50	

## SAE STANDARD CONNECTIONS

### OPF22711/OPF22711KR/OPF22711K

JIC FEMALE 37° CONE SEAT DOUBLE HEXAGON - SAE J516 / ISO 12151-5 (CRIMPED-BACK NUT)



FITTINGS  
F 9-10

PART. REF.	HOSE BORE			Thread	DIMENSIONS mm							
	DN	Dash	inch		T	B	A	C	F	H1	H2	
OPF22711-03A04K	5	- 3	3/16"	7/16" - 20	4	41,5	8,9	20	12	15		
OPF22711-04A04KR	6	- 4	1/4"	7/16" - 20	4	48	8,9	20,5	12	15		
OPF22711-04A05KR	6	- 4	1/4"	1/2" - 20	4	48,5	9,4	21	14	17		
OPF22711-04A06KR	6	- 4	1/4"	9/16" - 18	7	49	9,5	21,5	14	17		
OPF22711-05A05KR	8	- 5	5/16"	1/2" - 20	4	49,5	9,4	21,5	17	17		
OPF22711-06A06KR	10	- 6	3/8"	9/16" - 18	7	51,5	9,5	22	17	17		
OPF22711-06A08KR	10	- 6	3/8"	3/4" - 16	9,3	56	10,7	26,5	19	22		
OPF22711-08A06KR	12	- 8	1/2"	9/16" - 18	7	55,5	9,5	24	19	17		
OPF22711-08A08KR	12	- 8	1/2"	3/4" - 16	9,3	58	10,7	27	19	22		
OPF22711-08A10KR	12	- 8	1/2"	7/8" - 14	9,3	60,5	12,5	29,5	22	25		
OPF22711-08A12KR	12	- 8	1/2"	1.1/16" - 12	15	60	14,1	28,5	27	32		
OPF22711-10A08KR	16	- 10	5/8"	3/4" - 16	9,3	62,5	10,7	28,5	22	22		
OPF22711-10A10KR	16	- 10	5/8"	7/8" - 14	9,3	64	12,5	29,5	22	25		
OPF22711-10A12KR	16	- 10	5/8"	1.1/16" - 12	15	63,5	14,1	29	27	32		
OPF22711-12A08KR	19	- 12	3/4"	3/4" - 16	9,3	66	10,7	29,5	27	22		
OPF22711-12A10KR	19	- 12	3/4"	7/8" - 14	12,5	67	12,5	30,5	27	25		
OPF22711-12A12KR	19	- 12	3/4"	1.1/16" - 12	15	66,5	14,1	30	27	32		
OPF22711-12A16	19	- 12	3/4"	1.5/16" - 12	19,8	71	15,3	34,5	32	38		
OPF22711-16A12KR	25	- 16	1"	1.1/16" - 12	15	80,5	14,1	32,5	32	32		
OPF22711-16A16	25	- 16	1"	1.5/16" - 12	19,8	83,5	15,3	35,5	32	38		

KR:CRIMPED-BACK KOMPACT ROBUST NUT

## SAE STANDARD CONNECTIONS

### OPF22592/OPF22593

90° JIC FEMALE ELBOW 37° CONE SEAT - SAE J516 / ISO 12151-5

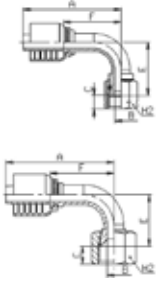

PART. REF.	HOSE BORE			Thread	DIMENSIONS mm							
	DN	Dash	inch		T	B	A	C	E	F	H2	
OPF22593-03A04	5	- 3	3/16"	7/16" - 20		3	47,5	8,5	23,5	26	15	
OPF22592-04A04	6	- 4	1/4"	7/16" - 20		4	56	8,7	27	28,5	17	
OPF22592-04A05	6	- 4	1/4"	1/2" - 20		4	56	9,1	27,5	28,5	17	
OPF22593-04A06	6	- 4	1/4"	9/16" - 18		4	57	9,8	28	29,5	19	
OPF22593-04A08	6	- 4	1/4"	3/4" - 16		7	57	10	30,5	29,5	22	
OPF22592-05A05	8	- 5	5/16"	1/2" - 20		5,5	59	9,1	28	31	17	
OPF22592-05A06	8	- 5	5/16"	9/16" - 18		7	59	9,2	28,5	31	19	
OPF22592-06A05	10	- 6	3/8"	1/2" - 20		5,5	59,5	9,1	26,5	30	17	
OPF22592-06A06	10	- 6	3/8"	9/16" - 18		7	65	9,2	32,5	35,5	19	
OPF22593-06A08	10	- 6	3/8"	3/4" - 16		7	66	10,1	29,5	36,5	22	
OPF22593-06A10	10	- 6	3/8"	7/8" - 14		9,3	66	12,4	31,5	36,5	27	
OPF22592-08A06	12	- 8	1/2"	9/16" - 18		7	68	9,2	33	37	19	
OPF22592-08A08	12	- 8	1/2"	3/4" - 16		9,3	75,5	10,2	41	44	22	
OPF22593-08A10	12	- 8	1/2"	7/8" - 14		9,3	76	12,4	36	45	27	
OPF22593-08A12	12	- 8	1/2"	1.1/16" - 12		12,5	76	14,1	36	45	32	
OPF22592-10A10	16	- 10	5/8"	7/8" - 14		12,5	88	12,3	52,5	53,5	27	
OPF22593-10A12	16	- 10	5/8"	1.1/16" - 12		12,5	86	14,1	50	51,5	32	
OPF22592-12A10	19	- 12	3/4"	7/8" - 14		12,5	91,5	12,3	52,5	55	27	
OPF22592-12A12	19	- 12	3/4"	1.1/16" - 12		15	98	14,2	58	62	32	
OPF22592-12A14	19	- 12	3/4"	1.3/16" - 12		15	99	14,3	58	63	36	
OPF22592-12A16	19	- 12	3/4"	1.5/16" - 12		19,8	99	15	57,5	63	38	
OPF22592-16A16	25	- 16	1"	1.5/16" - 12		19,8	124	15	68,5	76	38	
OPF22592-16A20	25	- 16	1"	1.5/8" - 12		26	125,5	16,2	74,5	77,5	50	

OPF22592: THRUST-WIRE NUT / OPF22593: SLIP-ON NUT

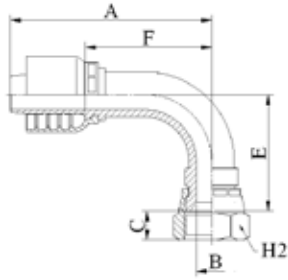

## SAE STANDARD CONNECTIONS

### OPF22591KR

90° ELBOW JIC FEMALE 37° CONE SEAT SAE J516 / ISO 12151-5  
(CRIMPED-BACK NUT)

PART. REF.	HOSE BORE			Thread		DIMENSIONS mm						
	DN	Dash	inch			T	B	A	C	E	F	H2
OPF22591-04A04KR	6	- 4	1/4"	7/16" - 20		4,2	56	8,9	26	28,5	15	
OPF22591-04A05KR	6	- 4	1/4"	1/2" - 20		4	56	9,4	26,5	28,5	17	
OPF22591-06A06KR	10	- 6	3/8"	9/16" - 18		7	65	9,5	32	35,5	17	
OPF22591-08A08KR	12	- 8	1/2"	3/4" - 16		9,3	75,5	10,7	40,5	44	22	
OPF22591-10A10KR	16	- 10	5/8"	7/8" - 14		12,5	88	12,5	47	53,5	25	
OPF22591-12A12KR	19	- 12	3/4"	1.1/16" - 12		15	98	14,1	57	62	32	

FITTINGS  
F 9-12

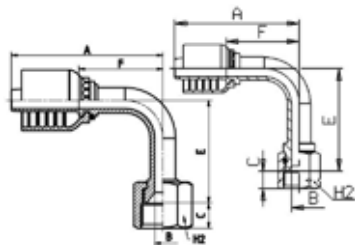

## SAE STANDARD CONNECTIONS

### OPF24792/OPF24793 LONG DROP

90° JIC FEMALE LONG DROP ELBOW 37° CONE SEAT - SAE J516 / ISO  
12151-5

PART. REF.	HOSE BORE			Thread		DIMENSIONS mm						
	DN	Dash	inch			T	B	A	C	E	F	H2
OPF24792-04A04	6	- 4	1/4"	7/16" - 20		4	56	8,7	45	28,5	17	
OPF24792-04A05	6	- 4	1/4"	1/2" - 20		4	56	9,1	45	28,5	17	
OPF24793-04A06	6	- 4	1/4"	9/16" - 18		4	57	9,8	55,5	29,5	19	
OPF24792-06A06	10	- 6	3/8"	9/16" - 18		7	65	9,2	55	35,5	19	
OPF24793-06A08	10	- 6	3/8"	3/4" - 16		7	66	10,1	61,5	36,5	22	
OPF24792-08A08	12	- 8	1/2"	3/4" - 16		9,3	75,5	10,2	61	44	22	
OPF24793-08A10	12	- 8	1/2"	7/8" - 14		9,3	76	12,4	65	45	27	
OPF24792-10A10	16	- 10	5/8"	7/8" - 14		12,5	88	12,3	65,5	53,5	27	
OPF24792-12A12	19	- 12	3/4"	1.1/16" - 12		15	98	14,2	94,5	62	32	
OPF24792-16A16	25	- 16	1"	1.5/16" - 12		19,8	125,5	15	110	77,5	38	

OPF24792: THRUST-WIRE NUT / OPF24793: SLIP-ON NUT

## SAE STANDARD CONNECTIONS

### OPF24791KR

90° LONG DROP ELBOW JIC FEMALE 37° CONE SEAT SAE J516 / ISO  
12151-5 (CRIMPED-BACK NUT)

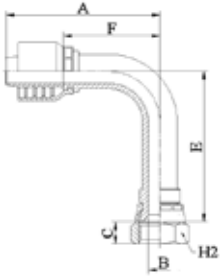

PART. REF.	HOSE BORE			Thread	DIMENSIONS mm						
	DN	Dash	inch		T	B	A	C	E	F	H2
OPF24791-04A04KR	6	- 4	1/4"	7/16" - 20	4,2	56	8,9	45	28,5	15	
OPF24791-06A06KR	10	- 6	3/8"	9/16" - 18	7	65	9,5	55	35,5	17	
OPF24791-08A08KR	12	- 8	1/2"	3/4" - 16	9,3	75,5	10,7	64	44	22	
OPF24791-10A10KR	16	- 10	5/8"	7/8" - 14	12,5	88	12,5	70	53,5	25	
OPF24791-12A12KR	19	- 12	3/4"	1.1/16" - 12	15	98	14,1	96	62	32	

## SAE STANDARD CONNECTIONS

### OPF22542/OPF22543

45° JIC FEMALE SWEPT ELBOW 37° CONE SEAT - SAE J516 / ISO  
12151-5

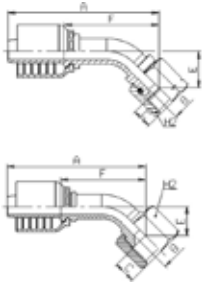

PART. REF.	HOSE BORE			Thread		DIMENSIONS mm						
	DN	Dash	inch			T	B	A	C	E	F	H2
OPF22542-04A04	6	- 4	1/4"	7/16" - 20		4	63	8,7	14,5	35,5	17	
OPF22542-04A05	6	- 4	1/4"	1/2" - 20		4	63	9,1	14,5	35,5	17	
OPF22543-04A06	6	- 4	1/4"	9/16" - 18		4	63	9,8	14	35,5	19	
OPF22542-05A05	8	- 5	5/16"	1/2" - 20		5,5	65,5	9,1	14	37,5	17	
OPF22542-05A06	8	- 5	5/16"	9/16" - 18		7	66	9,2	14,5	38	19	
OPF22542-06A06	10	- 6	3/8"	9/16" - 18		7	71,5	9,2	16,5	42	19	
OPF22543-06A08	10	- 6	3/8"	3/4" - 16		7	70,5	10,1	14	41	22	
OPF22543-06A10	10	- 6	3/8"	7/8" - 14		9,3	72	12,4	15,5	42,5	27	
OPF22542-08A08	12	- 8	1/2"	3/4" - 16		9,3	83	10,2	20	52	22	
OPF22543-08A10	12	- 8	1/2"	7/8" - 14		9,3	80,5	12,4	17	49,5	27	
OPF22543-08A12	12	- 8	1/2"	1.1/16" - 12		12,5	80,5	14,1	17	49,5	32	
OPF22542-10A10	16	- 10	5/8"	7/8" - 14		12,5	96,5	12,3	25,5	62	27	
OPF22543-10A12	16	- 10	5/8"	1.1/16" - 12		12,5	94,5	14,1	24	60	32	
OPF22542-12A12	19	- 12	3/4"	1.1/16" - 12		15	106	14,2	27,5	70	32	
OPF22542-12A14	19	- 12	3/4"	1.3/16" - 12		15	106	14,3	27,5	69,5	36	
OPF22542-12A16	19	- 12	3/4"	1.5/16" - 12		19,8	106,5	15	27,5	70	38	
OPF22542-16A12	25	- 16	1"	1.1/16" - 12		15	120,5	14,2	27,5	72,5	32	
OPF22542-16A16	25	- 16	1"	1.5/16" - 12		19,8	132,5	15	32	84	38	
OPF22542-16A20	25	- 16	1"	1.5/8" - 12		26	138	16,2	36	90	50	

OPF22542: THRUST-WIRE NUT / OPF22543: SLIP-ON NUT

## SAE STANDARD CONNECTIONS

### OPF22541KR

45° ELBOW JIC FEMALE 37° CONE SEAT SAE J516 / ISO 12151-5  
(CRIMPED-BACK NUT)

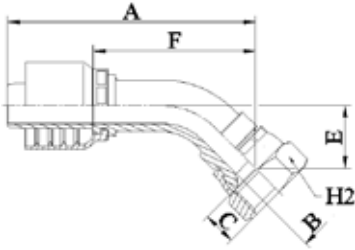

PART. REF.	HOSE BORE			Thread		DIMENSIONS mm						
	DN	Dash	inch			T	B	A	C	E	F	H2
OPF22541-04A04KR	6	- 4	1/4"	7/16" - 20		4,2	62	8,9	13,5	34,5	15	
OPF22541-04A05KR	6	- 4	1/4"	1/2" - 20		4	62,5	9,4	14	35	17	
OPF22541-06A06KR	10	- 6	3/8"	9/16" - 18		7	71,5	9,5	16	42	17	
OPF22541-08A08KR	12	- 8	1/2"	3/4" - 16		9,3	83	10,7	20	52	22	
OPF22541-10A10KR	16	- 10	5/8"	7/8" - 14		12,5	95,5	12,5	22,5	61	25	
OPF22541-12A12KR	19	- 12	3/4"	1.1/16" - 12		15	105,5	14,1	26,5	69	32	

## SAE STANDARD CONNECTIONS

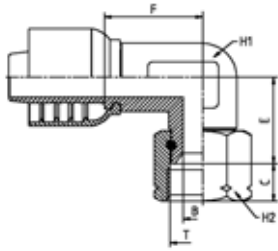

### OPF22582F

**90° JIC FEMALE COMPACT ELBOW 37° CONE SEAT SAE J516 / ISO 12151-5 (THRUST-WIRE NUT)**

PART. REF.	HOSE BORE			Thread	DIMENSIONS mm							
	DN	Dash	inch		T	B	A	C	E	F	H1	H2
OPF22582-04A04F	6	-4	1/4"	7/16" - 20	4	47,5	8,7	20,5	20	14	17	
OPF22582-04A06F	6	-4	1/4"	9/16" - 18	7	47,5	9,2	21,5	20	14	19	
OPF22582-06A06F	10	-6	3/8"	9/16" - 18	7	52,5	9,2	24	23	19	19	
OPF22582-06A08F	10	-6	3/8"	3/4" - 16	9,3	56	10,2	28	26,5	22	22	
OPF22582-08A08F	12	-8	1/2"	3/4" - 16	9,3	56	10,2	28	25	22	22	
OPF22582-08A10F	12	-8	1/2"	7/8" - 14	12,5	56	12,3	29	25	22	27	
OPF22582-12A12F	19	-12	3/4"	1.1/16" - 12	15	74	14,2	33	37,5	27	32	
OPF22582-16A16F	25	-16	1"	1.5/16" - 12	20	100	15	40	52	36	38	

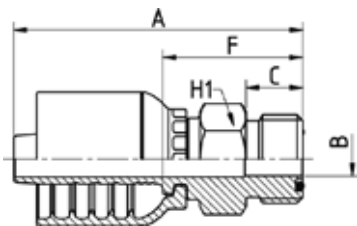

## SAE STANDARD CONNECTIONS

### OPF12410

**ORFS MALE - SAE J516 / ISO 12151-1**

PART. REF.	HOSE BORE			Thread	DIMENSIONS mm							
	DN	Dash	inch		T	B	A	C	F	H1		
OPF12410-04A04	6	-4	1/4"	9/16" - 18	4	51,5	9,8	24	16			
OPF12410-04A06	6	-4	1/4"	11/16" - 16	6,7	54	11,2	26,5	19			
OPF12410-05A06	8	-5	5/16"	11/16" - 16	6,7	55	11,2	27	19			
OPF12410-06A06	10	-6	3/8"	11/16" - 16	6,7	57	11,2	27,5	19			
OPF12410-06A08	10	-6	3/8"	13/16" - 16	9,3	59,5	12,8	30	22			
OPF12410-08A08	12	-8	1/2"	13/16" - 16	9,3	61,5	12,8	30,5	22			
OPF12410-08A10	12	-8	1/2"	1" - 14	12,5	66	15,5	35	27			
OPF12410-10A10	16	-10	5/8"	1" - 14	12,5	69	15,5	34,5	27			
OPF12410-10A12	16	-10	5/8"	1.3/16" - 12	15	72	17	37,5	32			
OPF12410-12A12	19	-12	3/4"	1.3/16" - 12	15	75,5	17	39	32			
OPF12410-12A16	19	-12	3/4"	1.7/16" - 12	19,8	77	17,5	40,5	38			
OPF12410-16A16	25	-16	1"	1.7/16" - 12	19,8	90	17,5	42	38			



## SAE STANDARD CONNECTIONS

### OPF22411

ORFS FEMALE - SAE J516 / ISO 12151-1 PULL-BACK TYPE

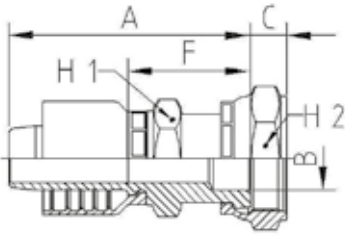

PART. REF.	HOSE BORE			Thread	DIMENSIONS mm						
	DN	Dash	inch		T	B	A	C	F	H1	H2
OPF22411-04A04	6	-4	1/4"	9/16" - 18	4	55	8	27,5	13	19	
OPF22411-04A06	6	-4	1/4"	11/16" - 16	7	57,5	9,5	30	16	22	
OPF22411-05A06	8	-5	5/16"	11/16" - 16	7	58,5	9,5	30,5	16	22	
OPF22411-06A06	10	-6	3/8"	11/16" - 16	7	60,5	9,5	31	16	22	
OPF22411-06A08	10	-6	3/8"	13/16" - 16	9,3	65	11	35,5	19	24	
OPF22411-08A06	12	-8	1/2"	11/16" - 16	7	63	9,5	32	19	22	
OPF22411-08A08	12	-8	1/2"	13/16" - 16	9,3	67	11	36	19	24	
OPF22411-08A10	12	-8	1/2"	1" - 14	11,5	69,5	13,5	38,5	24	30	
OPF22411-08A12	12	-8	1/2"	1.3/16" - 12	13,9	73	14,5	42	28	36	
OPF22411-10A10	16	-10	5/8"	1" - 14	11,5	73	13,5	38,5	24	30	
OPF22411-10A12	16	-10	5/8"	1.3/16" - 12	13,9	76,5	14,5	42	28	36	
OPF22411-12A10	19	-12	3/4"	1" - 14	11,5	77,5	13,5	41	28	30	
OPF22411-12A12	19	-12	3/4"	1.3/16" - 12	13,9	80	14,5	43,5	28	36	
OPF22411-12A16	19	-12	3/4"	1.7/16" - 12	19,8	82	15	45,5	36	41	
OPF22411-16A12	25	-16	1"	1.3/16" - 12	13,9	94	13,5	48	36	36	
OPF22411-16A16	25	-16	1"	1.7/16" - 12	19,8	94,5	15	46,5	36	41	

## SAE STANDARD CONNECTIONS

### OPF22491/OPF22493

90° ORFS FEMALE SWEPT ELBOW - SAE J516 / ISO 12151-1

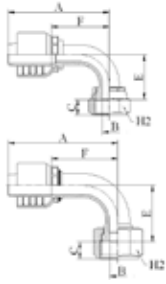

PART. REF.	HOSE BORE			Thread	DIMENSIONS mm						
	DN	Dash	inch		T	B	A	C	E	F	H2
OPF22493-04A04	6	- 4	1/4"	9/16" - 18	4	55	8,2	22	27,5	17	
OPF22493-04A06	6	- 4	1/4"	11/16" - 16	7	55	9,5	22	27,5	22	
OPF22493-05A06	8	- 5	5/16"	11/16" - 16	7	60	9,5	23	32	22	
OPF22493-06A06	10	- 6	3/8"	11/16" - 16	6	59,5	9,5	24	30	22	
OPF22493-06A08	10	- 6	3/8"	13/16" - 16	9,3	59,5	11	26,5	30	24	
OPF22491-08A06	12	- 8	1/2"	11/16" - 16	7	61,5	9,5	24,5	30	22	
OPF22493-08A08	12	- 8	1/2"	13/16" - 16	9	71,5	11	30	40,5	24	
OPF22493-08A10	12	- 8	1/2"	1" - 14	11,5	71	13,5	30,5	40	30	
OPF22493-08A12	12	- 8	1/2"	1.3/16" - 12	13,9	71	14,5	37,5	39,5	36	
OPF22493-10A10	16	- 10	5/8"	1" - 14	11,5	82,5	13,5	37,5	48	30	
OPF22493-10A12	16	- 10	5/8"	1.3/16" - 12	13,9	82,5	14,5	41	48	36	
OPF22491-12A10	19	- 12	3/4"	1" - 14	11,5	85,5	13,5	38	49	30	
OPF22493-12A12	19	- 12	3/4"	1.3/16" - 12	13,9	93	14,5	48	56,5	36	
OPF22493-12A16	19	- 12	3/4"	1.7/16" - 12	19,8	93	14,8	47,5	56,5	41	
OPF22491-16A12	25	- 16	1"	1.3/16" - 12	13,9	106	14,5	48	57,5	36	
OPF22493-16A16	25	- 16	1"	1.7/16" - 12	19,8	119,5	14,8	56	71,5	41	
OPF22493-16A20	25	- 16	1"	1.11/16" - 12	26	119,5	14,8	58,5	71,5	50	

OPF22491: CRIMPED-BACK NUT / OPF22493: SLIP-ON NUT

## SAE STANDARD CONNECTIONS

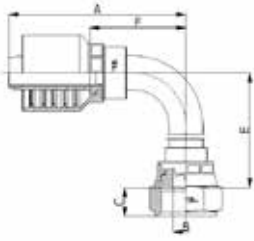

### OPF24491 LONG DROP

**90° ORFS FEMALE LONG DROP ELBOW - SAE J516 / ISO 12151-1  
(CRIMPED-BACK NUT)**

PART. REF.	HOSE BORE			Thread	DIMENSIONS mm							
	DN	Dash	inch		T	B	A	C	E	F	H2	
OPF24491-04A04	6	- 4	1/4"	9/16" - 18	4,4	52,5	8	46	25	17		
OPF24491-06A06	10	- 6	3/8"	11/16" - 16	6,7	61,5	9,5	54	32	22		
OPF24491-06A08	10	- 6	3/8"	13/16" - 16	6,7	61,5	11	54	32	24		
OPF24491-08A08	12	- 8	1/2"	13/16" - 16	9,6	68	11	64	37	24		
OPF24491-08A10	12	- 8	1/2"	1" - 14	9,6	68	12,5	64,5	37	30		
OPF24491-10A10	16	- 10	5/8"	1" - 14	12	75,5	13	70	41	30		
OPF24491-10A12	16	- 10	5/8"	1.3/16" - 12	12,7	75,5	13,5	73	41	36		
OPF24491-12A12	19	- 12	3/4"	1.3/16" - 12	15	95	13,5	96	58,5	36		
OPF24491-16A16	25	- 16	1"	1.7/16" - 12	19,8	119,5	13,5	114	71,5	41		

All items are made from brazing with the exception of OPF24491-12A12 and OPF24491-16A16

## SAE STANDARD CONNECTIONS

### OPF22441/OPF22443

45° ORFS FEMALE ELBOW - SAE J516 / ISO 12151-1

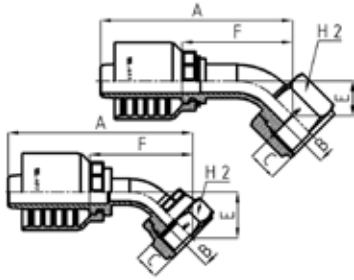

PART. REF.	HOSE BORE			Thread	DIMENSIONS mm						
	DN	Dash	inch		T	B	A	C	E	F	H2
OPF22443-04A04	6	-4	1/4"	9/16" - 18	4	58,5	8,2	10,5	31	17	
OPF22443-04A06	6	-4	1/4"	11/16" - 16	7	58,5	9,5	10,5	31	22	
OPF22443-05A06	8	-5	5/16"	11/16" - 16	7	62	9,5	10,5	34	22	
OPF22443-06A06	10	-6	3/8"	11/16" - 16	6	61,5	9,5	11	32,5	22	
OPF22443-06A08	10	-6	3/8"	13/16" - 16	9,3	63	11	12,5	34	24	
OPF22441-08A06	12	-8	1/2"	11/16" - 16	7	63,5	9,5	11	32,5	22	
OPF22443-08A08	12	-8	1/2"	13/16" - 16	9	73	11	13	42	24	
OPF22443-08A10	12	-8	1/2"	1" - 14	11,5	73	13,5	13,5	42	30	
OPF22443-08A12	12	-8	1/2"	1.3/16" - 12	13,9	78	14,5	18,5	46,5	36	
OPF22443-10A10	16	-10	5/8"	1" - 14	11,5	83,5	13,5	16	49	30	
OPF22443-10A12	16	-10	5/8"	1.3/16" - 12	13,9	86	14,5	18,5	51,5	36	
OPF22441-12A10	19	-12	3/4"	1" - 14	11,5	87	13,5	16,5	50,5	30	
OPF22443-12A12	19	-12	3/4"	1.3/16" - 12	13,9	97	14,5	21,5	60,5	36	
OPF22443-12A16	19	-12	3/4"	1.7/16" - 12	19,8	96,5	14,8	21	60	41	
OPF22443-16A16	25	-16	1"	1.7/16" - 12	19,8	120	14,8	23,5	72	41	
OPF22443-16A20	25	-16	1"	1.11/16" - 12	26	122	14,8	25	74	50	

OPF22441: CRIMPED-BACK NUT / OPF22443: SLIP-ON NUT

## SAE STANDARD CONNECTIONS

### OPF13010

SAE MALE O-RING BOSS TYPE - SAE J516 / ISO 11926

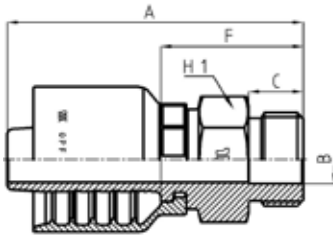

PART. REF.	HOSE BORE			Thread	DIMENSIONS mm						
	DN	Dash	inch		T	B	A	C	F	H1	
OPF13010-04A04	6	-4	1/4"	7/16" - 20	4,4	51,5	9,1	24	14		
OPF13010-04A06	6	-4	1/4"	9/16" - 18	7,5	52	9,9	24,5	17		
OPF13010-06A06	10	-6	3/8"	9/16" - 18	7,5	55	9,9	25,5	17		
OPF13010-06A08	10	-6	3/8"	3/4" - 16	9,9	58	11,1	28,5	22		
OPF13010-08A08	12	-8	1/2"	3/4" - 16	9,9	60	11,1	29	22		
OPF13010-08A10	12	-8	1/2"	7/8" - 14	12,3	63	12,7	32	25		
OPF13010-10A10	16	-10	5/8"	7/8" - 14	12,5	63	12,7	32	25		
OPF13010-10A12	16	-10	5/8"	1.1/16" - 12	15,5	72	15,1	37,5	32		
OPF13010-12A12	19	-12	3/4"	1.1/16" - 12	15,5	76	15,1	39,5	32		
OPF13010-12A16	19	-12	3/4"	1.5/16" - 12	21,5	76,5	15,1	40	38		
OPF13010-16A16	25	-16	1"	1.5/16" - 12	21,5	89,5	15,1	41	38		

## SAE STANDARD CONNECTIONS

### OPF14310

SAE SWIVEL MALE OR.BOSS TYPE

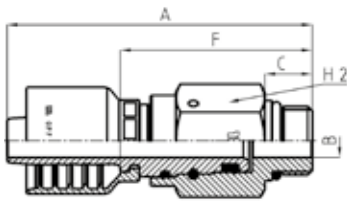

PART. REF.	HOSE BORE			Thread		DIMENSIONS mm						
	DN	Dash	inch			T	B	A	C	F	H2	
OPF14310-04A04	6	- 4	1/4"	7/16" - 20		4	70,5	9,1	43	17		
OPF14310-04A06	6	- 4	1/4"	9/16" - 18		7	71,5	9,9	44	22		
OPF14310-06A06	10	- 6	3/8"	9/16" - 18		7	77,5	9,9	48	22		
OPF14310-06A08	10	- 6	3/8"	3/4" - 16		9,3	76,5	11,1	47	22		
OPF14310-08A08	12	- 8	1/2"	3/4" - 16		9,3	84	11,1	53	27		
OPF14310-08A10	12	- 8	1/2"	7/8" - 14		9,3	72,4	13	41,5	27		
OPF14310-12A12	19	- 12	3/4"	1.1/16" - 12		12,5	87	15	50,5	32		

Not to be used as a live swivel

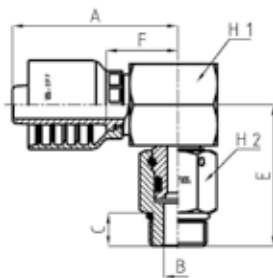

## SAE STANDARD CONNECTIONS

### OPF14390

90° SAE SWIVEL MALE OR.BOSS

PART. REF.	HOSE BORE			Thread		DIMENSIONS mm						
	DN	Dash	inch			T	B	A	C	E	F	H1
OPF14390-06A06	10	- 6	3/8"	9/16" - 18		5,7	49,5	9,9	40	20	22	17
OPF14390-06A08	10	- 6	3/8"	3/4" - 16		9,3	49,5	11,1	44,5	20	22	22
OPF14390-08A08	12	- 8	1/2"	3/4" - 16		9,3	54,5	11,1	47	23,5	27	22
OPF14390-08A10	12	- 8	1/2"	7/8" - 14		9,8	54,5	13	47	23,5	27	27
OPF14390-10A10	16	- 10	5/8"	7/8" - 14		9,8	58	13	47	23,5	27	27
OPF14390-12A12	19	- 12	3/4"	1.1/16" - 12		13	64,5	15	58,5	28	34	32

Not to be used as a live swivel

## SAE STANDARD CONNECTIONS

### OPF22612

SAE FEMALE 45° CONE SEAT - SAE J516/J512 (THRUST-WIRE NUT)

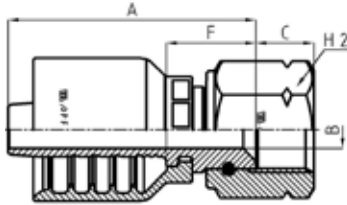

PART. REF.	HOSE BORE			Thread	DIMENSIONS mm							
	DN	Dash	inch		T	B	A	C	F	H2		
OPF22612-06A06	10	-6	3/8"	9/16" - 18		7	46	10,8	16,5	22		

## SAE STANDARD CONNECTIONS

### OPF12810

NPTF MALE 60° CONE SEAT - SAE J516/J514

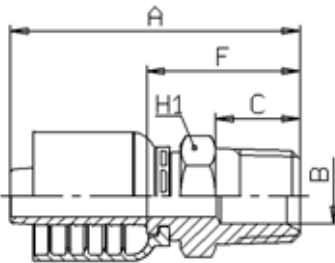

PART. REF.	HOSE BORE			Thread	DIMENSIONS mm							
	DN	Dash	inch		T	B	A	C	F	H1		
OPF12810-03A02	5	-3	3/16"	1/8" - 27		3	45	10	23,5	12		
OPF12810-03A04	5	-3	3/16"	1/4" - 18		5,5	50,5	14,5	29	14		
OPF12810-04A02	6	-4	1/4"	1/8" - 27		4	51,5	10	24	12		
OPF12810-04A04	6	-4	1/4"	1/4" - 18		5,5	56,5	14,5	29	14		
OPF12810-04A06	6	-4	1/4"	3/8" - 18		9,3	55	14,5	27,5	19		
OPF12810-04A08	6	-4	1/4"	1/2" - 14		9,3	61	19,2	33,5	24		
OPF12810-05A04	8	-5	5/16"	1/4" - 18		5,5	57,5	14,5	29,5	14		
OPF12810-05A06	8	-5	5/16"	3/8" - 18		9,3	60	14,5	32	19		
OPF12810-06A04	10	-6	3/8"	1/4" - 18		5,5	59,5	14,5	30	14		
OPF12810-06A06	10	-6	3/8"	3/8" - 18		9,3	58	14,5	28,5	19		
OPF12810-06A08	10	-6	3/8"	1/2" - 14		12,5	64	19,2	34,5	24		
OPF12810-08A06	12	-8	1/2"	3/8" - 18		9,3	60	14,5	29	19		
OPF12810-08A08	12	-8	1/2"	1/2" - 14		12,5	66	19,2	35	24		
OPF12810-08A12	12	-8	1/2"	3/4" - 14		15,5	66,5	19,2	35,5	27		
OPF12810-10A08	16	-10	5/8"	1/2" - 14		12,5	73	19,2	38,5	24		
OPF12810-10A12	16	-10	5/8"	3/4" - 14		16	74,5	19,2	40	27		
OPF12810-12A08	19	-12	3/4"	1/2" - 14		12,5	73	19,2	36,5	27		
OPF12810-12A12	19	-12	3/4"	3/4" - 14		16	73	19,2	36,5	27		
OPF12810-12A16	19	-12	3/4"	1" - 11,5		19,8	82,5	24,2	46	36		
OPF12810-16A12	25	-16	1"	3/4" - 14		15,5	87	19,2	39	32		
OPF12810-16A16	25	-16	1"	1" - 11,5		19,8	92	24,2	44	36		
OPF12810-16A20	25	-16	1"	1.1/4" - 11,5		26	104,5	25	56,5	46		

## SAE STANDARD CONNECTIONS

### OPF14110R

SWIVEL MALE NPTF

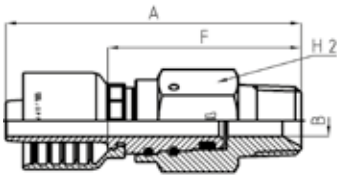

PART. REF.	HOSE BORE			Thread	DIMENSIONS mm							
	DN	Dash	inch		T	B	A	C	F	H1		
OPF14110-04A02R	6	- 4	1/4"	1/8" - 28		3	69,5	10	42	17		
OPF14110-04A04R	6	- 4	1/4"	1/4" - 18		4	74	14,5	46,5	17		
OPF14110-04A06R	6	- 4	1/4"	3/8" - 18		7	74	14,5	46,5	19		
OPF14110-06A04R	10	- 6	3/8"	1/4" - 18		4	80	14,5	50,5	22		
OPF14110-06A06R	10	- 6	3/8"	3/8" - 18		7	80	14,5	50,5	22		
OPF14110-06A08R	10	- 6	3/8"	1/2" - 14		9,3	84,5	19,2	55	24		
OPF14110-08A08R	12	- 8	1/2"	1/2" - 14		9,3	90	19,2	59	27		
OPF14110-12A12R	19	- 12	3/4"	3/4" - 14		16	94,5	19,2	58	32		
OPF14110-16A16R	25	- 16	1"	1" - 11		19,8	114	24,2	66	38		

Not to be used as a live swivel

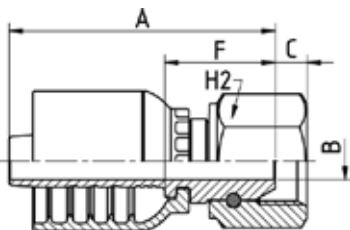

## SAE STANDARD CONNECTIONS

### OPF22812

NPSM FEMALE 60° CONE - SAE J516/J514 (THRUST-WIRE NUT)

PART. REF.	HOSE BORE			Thread	DIMENSIONS mm							
	DN	Dash	inch		T	B	A	C	F	H2		
OPF22812-04A04	6	- 4	1/4"	1/4" - 18		4	45	4,2	17,5	19		
OPF22812-06A06	10	- 6	3/8"	3/8" - 18		7	50,5	6	21	22		
OPF22812-08A08	12	- 8	1/2"	1/2" - 14		9,3	54	6,5	23	27		
OPF22812-12A12	19	- 12	3/4"	3/4" - 14		15	61	9	24,5	32		
OPF22812-16A16	25	- 16	1"	1" - 11,5		19,8	75,5	10,5	27,5	38		



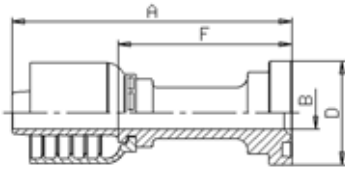

## SAE STANDARD CONNECTIONS

### OPF23311

ISO/SAE CODE 61 FLANGE - SAE J516 / ISO 12151-3

PART. REF.	HOSE BORE			Flange		DIMENSIONS mm					
	DN	Dash	inch			Inch	B	A	D	F	
OPF23311-08A08	12	- 8	1/2"	1/2"		9,3	82	30,3	51		
OPF23311-08A12	12	- 8	1/2"	3/4"		15,1	89	38	58		
OPF23311-10A12	16	- 10	5/8"	3/4"		15	100	38	65,5		
OPF23311-12A12	19	- 12	3/4"	3/4"		15	94,5	38	58		
OPF23311-12A16	19	- 12	3/4"	1"		20	94,5	44,6	58		
OPF23311-16A16	25	- 16	1"	1"		19,8	112,5	44,6	64,5		
OPF23311-16A20	25	- 16	1"	1.1/4"		26	118,5	51	70,5		

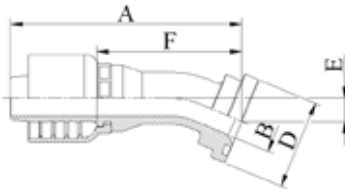

## SAE STANDARD CONNECTIONS

### OPF23321

22,5° ISO/SAE CODE 61 FLANGE - SAE J516 / ISO 12151-3

PART. REF.	HOSE BORE			Flange		DIMENSIONS mm					
	DN	Dash	inch			Inch	B	A	D	E	F
OPF23321-08A08	12	- 8	1/2"	1/2"		9,3	95	30,3	8	64	
OPF23321-12A12	19	- 12	3/4"	3/4"		15	111	38	10	74,5	
OPF23321-12A16	19	- 12	3/4"	1"		20	111	44,6	10	74,5	
OPF23321-16A16	25	- 16	1"	1"		19,8	137	44,6	11,5	89	

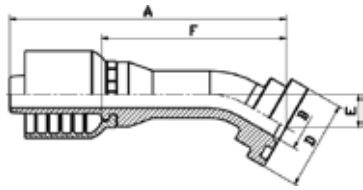

## SAE STANDARD CONNECTIONS

### OPF23331

30° ISO/SAE CODE 61 FLANGE - SAE J516 / ISO 12151-3

PART. REF.	HOSE BORE			Flange	DIMENSIONS mm						
	DN	Dash	inch		Inch	B	A	D	E	F	
OPF23331-08A08	12	- 8	1/2"	1/2"	9,3	93,5	30,3	11	62,5		
OPF23331-12A12	19	- 12	3/4"	3/4"	15	109,5	38	14	73		
OPF23331-12A16	19	- 12	3/4"	1"	20	109,5	44,6	14	73		
OPF23331-16A16	25	- 16	1"	1"	19,8	135	44,6	16,5	87		

FITTINGS  
F 9-26

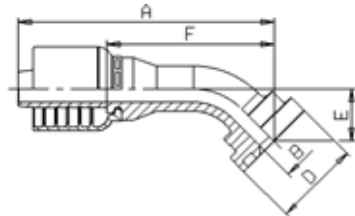

## SAE STANDARD CONNECTIONS

### OPF23341

45° ISO/SAE CODE 61 FLANGE - SAE J516 / ISO 12151-3

PART. REF.	HOSE BORE			Flange	DIMENSIONS mm						
	DN	Dash	inch		Inch	B	A	D	E	F	
OPF23341-08A08	12	- 8	1/2"	1/2"	9,3	90	30,3	18,5	58,5		
OPF23341-08A12	12	- 8	1/2"	3/4"	15	90,5	38	19	59,5		
OPF23341-10A12	16	- 10	5/8"	3/4"	15	95	38	22	61		
OPF23341-12A12	19	- 12	3/4"	3/4"	15	104,5	38	23	68,5		
OPF23341-12A16	19	- 12	3/4"	1"	20	104,5	44,6	23	68,5		
OPF23341-16A16	25	- 16	1"	1"	19,8	129,5	44,6	27,5	81,5		
OPF23341-16A20	25	- 16	1"	1.1/4"	26	129,5	51	27,5	81,5		

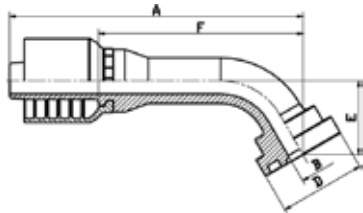

## SAE STANDARD CONNECTIONS

### OPF23361

60° ISO/SAE CODE 61 FLANGE - SAE J516 / ISO 12151-3

PART. REF.	HOSE BORE			Flange	DIMENSIONS mm						
	DN	Dash	inch		Inch	B	A	D	E	F	
OPF23361-08A08	12	- 8	1/2"	1/2"	9,3	102,5	30,3	26	71,5		
OPF23361-12A12	19	- 12	3/4"	3/4"	15	123,5	38	33	87		
OPF23361-16A16	25	- 16	1"	1"	19,8	152	44,6	39	104		
OPF23361-16A20	25	- 16	1"	1.1/4"	26	152	51	39	104		

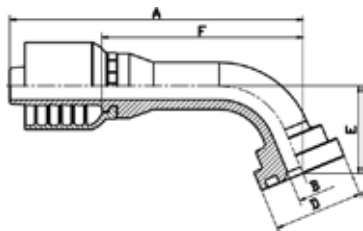

## SAE STANDARD CONNECTIONS

### OPF23371

67,5° ISO/SAE CODE 61 FLANGE - SAE J516 / ISO 12151-3

PART. REF.	HOSE BORE			Flange	DIMENSIONS mm						
	DN	Dash	inch		Inch	B	A	D	E	F	
OPF23371-08A08	12	- 8	1/2"	1/2"	9,3	99	30,3	29,5	68		
OPF23371-12A12	19	- 12	3/4"	3/4"	15	118,5	38	38	82		
OPF23371-12A16	19	- 12	3/4"	1"	20	118,5	44,6	38	82		
OPF23371-16A16	25	- 16	1"	1"	19,8	147	44,6	45	98,5		

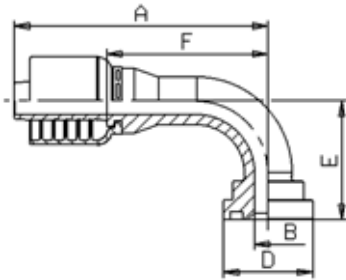

## SAE STANDARD CONNECTIONS

### OPF23391

90° ISO/SAE CODE 61 FLANGE - SAE J516 / ISO 12151-3

PART. REF.	HOSE BORE			Flange	DIMENSIONS mm						
	DN	Dash	inch		Inch	B	A	D	E	F	
OPF23391-08A08	12	- 8	1/2"	1/2"	9,3	85,5	30,3	40	54,5		
OPF23391-08A12	12	- 8	1/2"	3/4"	15	85,5	38	41	54,5		
OPF23391-10A12	16	- 10	5/8"	3/4"	15	90	38	47,5	56		
OPF23391-12A12	19	- 12	3/4"	3/4"	15	101	38	52	64,5		
OPF23391-12A16	19	- 12	3/4"	1"	20	101	44,6	52	64,5		
OPF23391-16A16	25	- 16	1"	1"	19,8	125,5	44,6	62	77,5		
OPF23391-16A20	25	- 16	1"	1.1/4"	26	125,5	51	62	77,5		

## DIN STANDARD CONNECTIONS

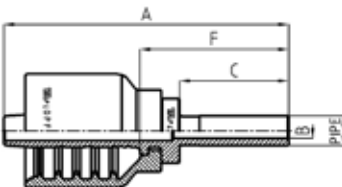

### OPF22010

METRIC STANDPIPE STRAIGHT L.T.

PART. REF.	HOSE BORE			Pipe	DIMENSIONS mm					
	DN	Dash	inch		mm	B	A	C	F	
OPF22010-04A06	6	- 4	1/4"	6	3	57,5	22	30		
OPF22010-06A10	10	- 6	3/8"	10	7	61	23	31,5		

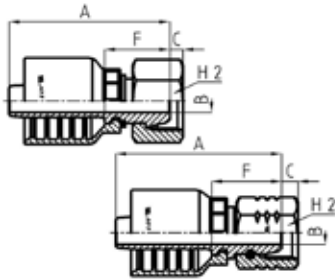

## DIN STANDARD CONNECTIONS

### OPF21312/OPF21313

METRIC FEMALE MULTISEAL

PART. REF.	HOSE BORE			Thread	Pipe	DIMENSIONS mm						
	DN	Dash	inch			T	mm	B	A	C	F	H2
OPF21312-06A16	10	-6	3/8"	M 16x1,5	10	7	51	5	21,5	19		
OPF21313-06A18	10	-6	3/8"	M 18x1,5	12	7	49,5	4	20	22		
OPF21313-08A22	12	-8	1/2"	M 22x1,5	15	9,3	52,5	4,7	21,5	27		

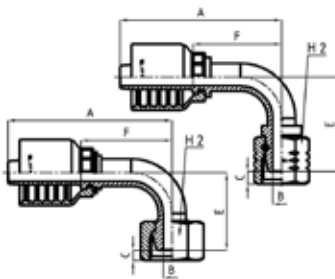

## DIN STANDARD CONNECTIONS

### OPF21392/OPF21393

90° METRIC FEMALE MULTISEAL

PART. REF.	HOSE BORE			Thread	Pipe	DIMENSIONS mm						
	DN	Dash	inch			T	mm	B	A	C	E	F
OPF21392-06A16	10	-6	3/8"	M 16x1,5	10	7	65	5	38	35,5	19	
OPF21393-06A18	10	-6	3/8"	M 18x1,5	12	7	66	4	31,5	36,5	22	

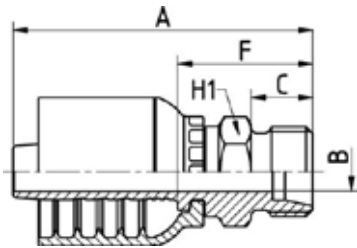

## DIN STANDARD CONNECTIONS

### OPF11110

METRIC MALE 24° CONE SEAT LIGHT DUTY - DIN 20066 / ISO 12151-2

PART. REF.	HOSE BORE			Thread	Pipe	DIMENSIONS mm						
	DN	Dash	inch			T	mm	B	A	C	F	H1
OPF11110-04A12	6	- 4	1/4"	M 12x1,5	6	4	49	10	21,5	14		
OPF11110-04A14	6	- 4	1/4"	M 14x1,5	8	4	49	10	21,5	14		
OPF11110-04A16	6	- 4	1/4"	M 16x1,5	10	7	51	11	23,5	17		
OPF11110-04A18	6	- 4	1/4"	M 18x1,5	12	9	51	11	23,5	19		
OPF11110-05A16	8	- 5	5/16"	M 16x1,5	10	7	52	11	24	17		
OPF11110-05A18	8	- 5	5/16"	M 18x1,5	12	9	52	11	24	19		
OPF11110-06A16	10	- 6	3/8"	M 16x1,5	10	7	53,5	11	24	17		
OPF11110-06A18	10	- 6	3/8"	M 18x1,5	12	9	54	11	24,5	19		
OPF11110-06A22	10	- 6	3/8"	M 22x1,5	15	10	55	12	25,5	22		
OPF11110-08A22	12	- 8	1/2"	M 22x1,5	15	10	56,5	12	25,5	22		
OPF11110-08A26	12	- 8	1/2"	M 26x1,5	18	12,5	57,5	12	26,5	27		
OPF11110-10A22	16	- 10	5/8"	M 22x1,5	15	10	60	12	25,5	22		
OPF11110-10A26	16	- 10	5/8"	M 26x1,5	18	12,5	61	12	26,5	27		
OPF11110-12A30	19	- 12	3/4"	M 30x2	22	15	66,5	14	30	30		
OPF11110-16A36	25	- 16	1"	M 36x2	28	19,8	80,5	14	32,5	36		

## DIN STANDARD CONNECTIONS

### OPF21512/OPF21513

METRIC O-RING FEMALE 24° CONE LIGHT DUTY - DIN 20066 / ISO 12151-2

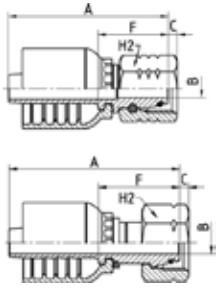

PART. REF.	HOSE BORE			Thread	Pipe	DIMENSIONS mm						
	DN	Dash	inch			T	mm	B	A	C	F	H2
OPF21512-04A12	6	- 4	1/4"	M 12x1,5	6	3	48,5	2,2	21	17		
OPF21513-04A14	6	- 4	1/4"	M 14x1,5	8	4	49,5	1,3	22	17		
OPF21513-04A16	6	- 4	1/4"	M 16x1,5	10	6	50	1,8	22,5	19		
OPF21513-04A18	6	- 4	1/4"	M 18x1,5	12	7	49,5	2	22	22		
OPF21512-05A14	8	- 5	5/16"	M 14x1,5	8	4	48	2,9	20	17		
OPF21513-05A16	8	- 5	5/16"	M 16x1,5	10	6	50,5	1,8	22,5	19		
OPF21513-05A18	8	- 5	5/16"	M 18x1,5	12	7	50	2	22	22		
OPF21512-06A16	10	- 6	3/8"	M 16x1,5	10	6	52,5	3	23	19		
OPF21513-06A18	10	- 6	3/8"	M 18x1,5	12	7	52	2	22,5	22		
OPF21513-06A22	10	- 6	3/8"	M 22x1,5	15	9,3	54,5	1,5	25	27		
OPF21512-08A18	12	- 8	1/2"	M 18x1,5	12	7	60	2,9	29	22		
OPF21513-08A22	12	- 8	1/2"	M 22x1,5	15	9,3	56,5	1,5	25,5	27		
OPF21513-08A26	12	- 8	1/2"	M 26x1,5	18	12,5	57	2	26	32		
OPF21513-10A26	16	- 10	5/8"	M 26x1,5	18	12,5	60,5	2	26	32		
OPF21513-10A30	16	- 10	5/8"	M 30x2	22	15	68,5	3	34	36		
OPF21512-12A26	19	- 12	3/4"	M 26x1,5	18	12,5	67,5	2,3	31	32		
OPF21513-12A30	19	- 12	3/4"	M 30x2	22	15	64,5	3	28	36		
OPF21513-12A36	19	- 12	3/4"	M 36x2	28	20	65	3,7	28,5	41		
OPF21513-16A36	25	- 16	1"	M 36x2	28	19,8	77,5	3,7	29,5	41		

OPF21512: THRUST-WIRE NUT / OPF21513: SLIP-ON NUT

## DIN STANDARD CONNECTIONS

### OPF21592/OPF21593

90° METRIC O-RING FEMALE SWEPT ELBOW 24° CONE LIGHT DUTY  
DIN 20066 / ISO 12151-2

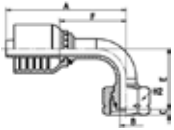
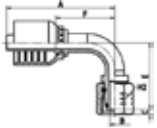

PART. REF.	HOSE BORE			Thread	Pipe	DIMENSIONS mm						
	DN	Dash	inch			T	mm	B	A	C	E	F
OPF21593-03A12	5	- 3	3/16"	M 12x1,5	6	3	47,5	0,7	30	26	14	
OPF21592-04A12	6	- 4	1/4"	M 12x1,5	6	3	56	2,2	32,5	28,5	17	
OPF21593-04A14	6	- 4	1/4"	M 14x1,5	8	4	57	1,3	31,5	29,5	17	
OPF21593-04A16	6	- 4	1/4"	M 16x1,5	10	6	57	1,8	32	29,5	19	
OPF21593-04A18	6	- 4	1/4"	M 18x1,5	12	7	57	2	33	29,5	22	
OPF21593-05A16	8	- 5	5/16"	M 16x1,5	10	6	60	1,8	32,5	32	19	
OPF21593-05A18	8	- 5	5/16"	M 18x1,5	12	7	60	2	32,5	32	22	
OPF21592-06A16	10	- 6	3/8"	M 16x1,5	10	6	65	3	40	35,5	19	
OPF21593-06A18	10	- 6	3/8"	M 18x1,5	12	7	66	2	33,5	36,5	22	
OPF21593-06A22	10	- 6	3/8"	M 22x1,5	15	9,3	66	1,5	35	36,5	27	
OPF21592-08A18	12	- 8	1/2"	M 18x1,5	12	7	75	2,9	48	44	22	
OPF21593-08A22	12	- 8	1/2"	M 22x1,5	15	9,3	76	1,5	39,5	45	27	
OPF21593-08A26	12	- 8	1/2"	M 26x1,5	18	12,5	76	2	40	45	32	
OPF21593-10A26	16	- 10	5/8"	M 26x1,5	18	12,5	86	2	53	51,5	32	
OPF21593-10A30	16	- 10	5/8"	M 30x2	22	15	86	3	54	51,5	36	
OPF21593-12A30	19	- 12	3/4"	M 30x2	22	15	97,5	3	59,5	61,5	36	
OPF21593-16A36	25	- 16	1"	M 36x2	28	19,8	125	3,7	69,5	76,5	41	

OPF21592: THRUST-WIRE NUT / OPF21593: SLIP-ON NUT



## DIN STANDARD CONNECTIONS

### OPF21542/OPF21543

45° METRIC O-RING FEMALE SWEPT ELBOW 24° CONE LIGHT DUTY  
DIN 20066 / ISO 12151-2

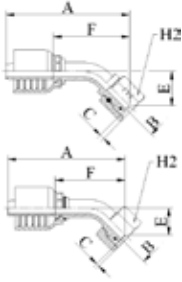

PART. REF.	HOSE BORE			Thread	Pipe	DIMENSIONS mm						
	DN	Dash	inch			T	mm	B	A	C	E	F
OPF21543-04A14	6	- 4	1/4"	M 14x1,5	8	4	65,5	1,3	16,5	38	17	
OPF21543-04A16	6	- 4	1/4"	M 16x1,5	10	6	65,5	1,8	17	38	19	
OPF21543-05A16	8	- 5	5/16"	M 16x1,5	10	6	69,5	1,8	17,5	41,5	19	
OPF21543-05A18	8	- 5	5/16"	M 18x1,5	12	7	69,5	2	17	41,5	22	
OPF21542-06A16	10	- 6	3/8"	M 16x1,5	10	6	77	3	21,5	47,5	19	
OPF21543-06A18	10	- 6	3/8"	M 18x1,5	12	7	73	2	16,5	43,5	22	
OPF21543-06A22	10	- 6	3/8"	M 22x1,5	15	9,3	74	1,5	18	45	27	
OPF21543-08A22	12	- 8	1/2"	M 22x1,5	15	9,3	83	1,5	19	52	27	
OPF21543-10A26	16	- 10	5/8"	M 26x1,5	18	12,5	96,5	2	26,5	62	32	
OPF21543-12A30	19	- 12	3/4"	M 30x2	22	15	107,5	3	28,5	71	36	
OPF21543-16A36	25	- 16	1"	M 36x2	28	19,8	133	3,7	32	85	41	

OPF21542: THRUST-WIRE NUT / OPF21543: SLIP-ON NUT

## DIN STANDARD CONNECTIONS

### OPF11210

METRIC MALE 24° CONE SEAT HEAVY DUTY - DIN 20066 / ISO 12151-2

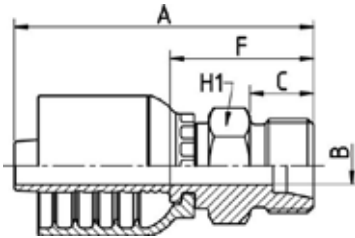

PART. REF.	HOSE BORE			Thread	Pipe	DIMENSIONS mm						
	DN	Dash	inch			T	mm	B	A	C	F	H1
OPF11210-04A16	6	- 4	1/4"	M 16x1,5	8	5,5	53	12	25,5	17		
OPF11210-04A18	6	- 4	1/4"	M 18x1,5	10	6	54	12	26,5	19		
OPF11210-04A20	6	- 4	1/4"	M 20x1,5	12	7	56,5	12	29	22		
OPF11210-05A20	8	- 5	5/16"	M 20x1,5	12	7	57	12	29	22		
OPF11210-06A18	10	- 6	3/8"	M 18x1,5	10	7	56,5	12	27	19		
OPF11210-06A20	10	- 6	3/8"	M 20x1,5	12	7	58,5	12	29	22		
OPF11210-06A22	10	- 6	3/8"	M 22x1,5	14	8	60,5	14	31	22		
OPF11210-08A24	12	- 8	1/2"	M 24x1,5	16	9,3	62,5	14	31,5	24		
OPF11210-10A30	16	- 10	5/8"	M 30x2	20	15	70	16	35,5	30		
OPF11210-12A30	19	- 12	3/4"	M 30x2	20	15	73,5	16	37	30		
OPF11210-12A36	19	- 12	3/4"	M 36x2	25	19,8	77,5	18	41	36		
OPF11210-16A36	25	- 16	1"	M 36x2	25	19,8	90,5	18	42,5	36		
OPF11210-16A42	25	- 16	1"	M 42x2	30	25	92,5	20	44,5	46		

## DIN STANDARD CONNECTIONS

### OPF21612/OPF21613

METRIC O-RING FEMALE 24° CONE HEAVY DUTY - DIN 20066 / ISO 12151-2

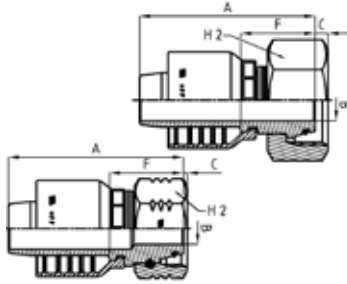

PART. REF.	HOSE BORE			Thread	Pipe	DIMENSIONS mm						
	DN	Dash	inch			T	mm	B	A	C	F	H2
OPF21613-03A16	5	- 3	3/16"	M 16x1,5	8	3	43	3,4	21,5	19		
OPF21613-04A14	6	- 4	1/4"	M 14x1,5	6	3	51	1,9	23,5	17		
OPF21613-04A16	6	- 4	1/4"	M 16x1,5	8	4	49,5	3,4	22	19		
OPF21613-04A18	6	- 4	1/4"	M 18x1,5	10	4	55,5	2,5	28	22		
OPF21613-04A20	6	- 4	1/4"	M 20x1,5	12	7	53,5	2	26	24		
OPF21613-05A18	8	- 5	5/16"	M 18x1,5	10	5,5	56	2,5	28	22		
OPF21613-05A20	8	- 5	5/16"	M 20x1,5	12	5,5	53	2	25	24		
OPF21613-06A20	10	- 6	3/8"	M 20x1,5	12	7	54,5	2	25,5	24		
OPF21613-06A22	10	- 6	3/8"	M 22x1,5	14	7	62	3	32,5	27		
OPF21613-08A24	12	- 8	1/2"	M 24x1,5	16	9,3	58	4	26,5	30		
OPF21613-10A30	16	- 10	5/8"	M 30x2	20	12,5	65	3,5	30,5	36		
OPF21612-12A30	19	- 12	3/4"	M 30x2	20	12,5	70	2,2	33,5	36		
OPF21613-12A36	19	- 12	3/4"	M 36x2	25	15	70,5	4,5	34	41		
OPF21612-16A36	25	- 16	1"	M 36x2	25	15	83,5	1,7	35,5	41		
OPF21613-16A42	25	- 16	1"	M 42x2	30	19,8	83,5	6,3	35,5	50		

OPF21612: THRUST-WIRE NUT / OPF21613: SLIP-ON NUT

## DIN STANDARD CONNECTIONS

### OPF21692/OPF21693

90° METRIC O-RING FEMALE SWEPT ELBOW 24° CONE HEAVY DUTY  
DIN 20066 / ISO 12151-2

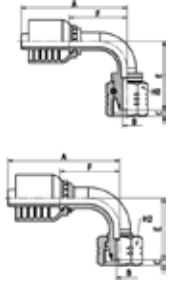

PART. REF.	HOSE BORE			Thread	Pipe	DIMENSIONS mm						
	DN	Dash	inch			T	mm	B	A	C	E	F
OPF21693-04A16	6	- 4	1/4"	M 16x1,5	8	4	57	3,4	29,5	29,5	19	
OPF21693-04A18	6	- 4	1/4"	M 18x1,5	10	4	57	2,5	31	29,5	22	
OPF21693-04A20	6	- 4	1/4"	M 20x1,5	12	5,5	57	2	34,5	29,5	24	
OPF21693-05A20	8	- 5	5/16"	M 20x1,5	12	5,5	60	2	34	32	24	
OPF21693-06A20	10	- 6	3/8"	M 20x1,5	12	7	66	2	35	36,5	24	
OPF21693-06A22	10	- 6	3/8"	M 22x1,5	14	7	66	3	37	36,5	27	
OPF21693-06A24	10	- 6	3/8"	M 24x1,5	16	9,3	66	4	36	36,5	30	
OPF21693-08A24	12	- 8	1/2"	M 24x1,5	16	9,3	76	4	40,5	45	30	
OPF21693-10A30	16	- 10	5/8"	M 30x2	20	12,5	86	3,5	57,5	51,5	36	
OPF21692-12A30	19	- 12	3/4"	M 30x2	20	12,5	98	2,2	67,5	61,5	36	
OPF21693-12A36	19	- 12	3/4"	M 36x2	25	15	97,5	4,5	64,5	61,5	41	
OPF21692-16A36	25	- 16	1"	M 36x2	25	15	127,5	1,7	86	79,5	41	
OPF21693-16A42	25	- 16	1"	M 42x2	30	19,8	127,5	6,3	74,5	79	50	

OPF21692: THRUST-WIRE NUT / OPF21693: SLIP-ON NUT

## DIN STANDARD CONNECTIONS

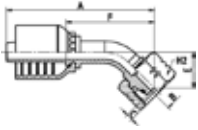
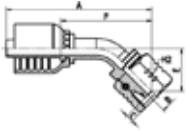

### OPF21642/OPF21643

**45° METRIC O-RING FEMALE SWEPT ELBOW 24° CONE HEAVY DUTY  
DIN 20066 / ISO 12151-2**

PART. REF.	HOSE BORE			Thread	Pipe	DIMENSIONS mm						
	DN	Dash	inch			T	mm	B	A	C	E	F
OPF21643-04A16	6	-4	1/4"	M 16x1,5	8	4	64	3,4	15	36,5	19	
OPF21643-04A18	6	-4	1/4"	M 18x1,5	10	4	65	2,5	16,5	37,5	22	
OPF21643-05A20	8	-5	5/16"	M 20x1,5	12	5,5	70	2	18,5	42	24	
OPF21643-06A20	10	-6	3/8"	M 20x1,5	12	7	73,5	2	17	44	24	
OPF21643-06A22	10	-6	3/8"	M 22x1,5	14	7	75	3	18,5	45,5	27	
OPF21643-08A24	12	-8	1/2"	M 24x1,5	16	9,3	83,5	4	20	52,5	30	
OPF21643-10A30	16	-10	5/8"	M 30x2	20	12,5	99,5	3,5	29,5	65,5	36	
OPF21642-12A30	19	-12	3/4"	M 30x2	20	12,5	113	2,2	34	76,5	36	
OPF21643-12A36	19	-12	3/4"	M 36x2	25	15	111,5	4,5	32,5	75	41	
OPF21643-16A42	25	-16	1"	M 42x2	30	19,8	138	6,3	35,5	90	50	

OPF21642: THRUST-WIRE NUT / OPF21643: SLIP-ON NUT

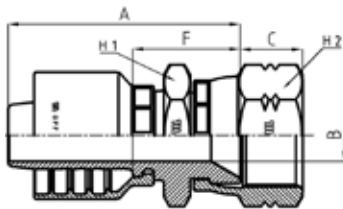

## JIS STANDARD CONNECTIONS

### OPF24011

**JIS METRIC FEMALE (KOMATSU)**

PART. REF.	HOSE BORE			Thread		DIMENSIONS mm						
	DN	Dash	inch			T	B	A	C	F	H1	H2
OPF24011-04A14	6	-4	1/4"	M 14x1,5		4	50,5	10,5	23	19	19	
OPF24011-06A14	10	-6	3/8"	M 14x1,5		4	53	10,5	23,5	19	19	
OPF24011-06A18	10	-6	3/8"	M 18x1,5		7	53	11,5	23,5	24	24	
OPF24011-08A22	12	-8	1/2"	M 22x1,5		9,3	56	13	25	27	27	
OPF24011-10A24	16	-10	5/8"	M 24x1,5		12,5	61	15,1	26,5	32	32	
OPF24011-12A30	19	-12	3/4"	M 30x1,5		15	68	18,3	31,5	36	36	
OPF24011-16A33	25	-16	1"	M 33x1,5		19,8	81,5	21,3	33,5	41	41	

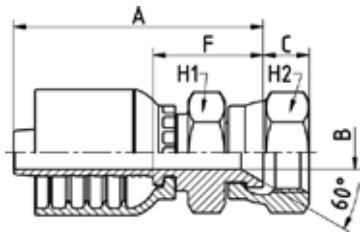

## JIS STANDARD CONNECTIONS

### OPF23811

JIS BSP FEMALE 60° CONE SEAT (TOYOTA) - JIS B 8363  
(CRIMPED-BACK NUT)

PART. REF.	HOSE BORE			Thread		DIMENSIONS mm						
	DN	Dash	inch			T	B	A	C	F	H1	H2
OPF23811-04A04	6	- 4	1/4"	1/4" - 19		4	46	8,3	18,5	19	19	
OPF23811-06A06	10	- 6	3/8"	3/8" - 19		7	52,5	10	23	22	22	
OPF23811-08A08	12	- 8	1/2"	1/2" - 14		9,3	53	11,5	22	27	27	
OPF23811-12A12	19	- 12	3/4"	3/4" - 14		15	62,5	13,5	26	32	32	
OPF23811-16A16	25	- 16	1"	1" - 11		19,8	78,5	14,5	30,5	38	38	

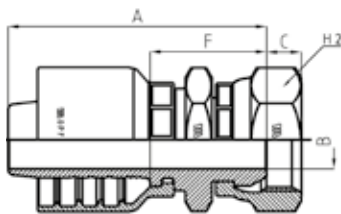

## JIS STANDARD CONNECTIONS

### OPF20711

JIS BSP FEMALE 60° CONE (NISSAN)  
JIS B 8363

PART. REF.	HOSE BORE			Thread		DIMENSIONS mm						
	DN	Dash	inch			T	B	A	C	F	H1	H2
OPF20711-12A12	19	- 12	3/4"	3/4" - 14		15	66,5	8,9	30	32	32	

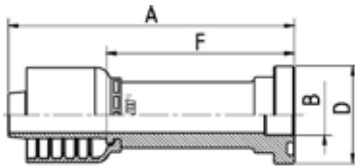

## ORIGINAL EQUIPMENT CONNECTIONS

### OPF24111

#### STRAIGHT KOMATSU FLANGE

PART. REF.	HOSE BORE			Flange	DIMENSIONS mm						
	DN	Dash	inch		Inch	B	A	D	F		
OPF24111-10A10	16	- 10	5/8"	5/8"	14	100	34	65,5			

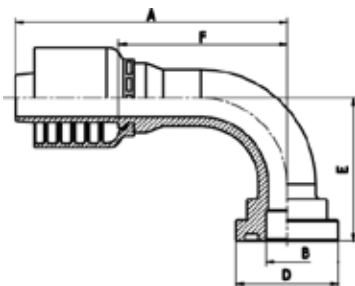

## ORIGINAL EQUIPMENT CONNECTIONS

### OPF24191

#### 90° KOMATSU FLANGE

PART. REF.	HOSE BORE			Flange	DIMENSIONS mm						
	DN	Dash	inch		Inch	B	A	D	E	F	
OPF24191-10A10	16	- 10	5/8"	5/8"	14	90	34	47,5	56		

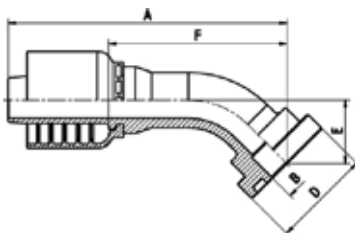

## ORIGINAL EQUIPMENT CONNECTIONS

### OPF24141

#### 45° KOMATSU FLANGE

PART. REF.	HOSE BORE			Flange	DIMENSIONS mm						
	DN	Dash	inch		Inch	B	A	D	E	F	
OPF24141-10A10	16	- 10	5/8"	5/8"	14	95	34	22	61		







**OPK**



FITTING CODE	SECTION	PAGE
OPK10510	10	1
OPK11110	10	27
OPK11210	10	31
OPK11710	10	33
OPK11810	10	33
OPK12410	10	14
OPK12510	10	10
OPK12810	10	20
OPK13010	10	19
OPK14110R	10	21
OPK14310	10	19
OPK20512-OPK20513	10	2
OPK20542-OPK20543	10	4
OPK20592-OPK20593	10	3
OPK20812-OPK20813	10	5
OPK20842-OPK20843	10	7
OPK20892-OPK20893	10	6
OPK21512-OPK21513	10	28
OPK21542-OPK21543	10	30
OPK21592-OPK21593	10	29
OPK21612-OPK21613	10	31
OPK21642-OPK21643	10	32
OPK21692-OPK21693	10	32
OPK21813	10	33
OPK22411	10	15
OPK22441-OPK22443	10	18
OPK22491-OPK22493	10	16
OPK22541KR	10	9

FITTING CODE	SECTION	PAGE
OPK22542-OPK22543	10	13
OPK22591KR	10	8
OPK22592-OPK22593	10	11
OPK22711-OPK22711KR	10	8
OPK22712	10	10
OPK22812	10	21
OPK23311	10	22
OPK23321	10	22
OPK23331	10	23
OPK23341	10	23
OPK23361	10	24
OPK23371	10	24
OPK23391	10	25
OPK23611	10	25
OPK23641	10	26
OPK23691	10	26
OPK23811	10	34
OPK23911	10	36
OPK23941	10	37
OPK23991	10	36
OPK24011-OPK24012	10	34
OPK24111	10	35
OPK24141	10	35
OPK24191	10	35
OPK24491 LONG DROP	10	17
OPK24791KR	10	9
OPK24792-OPK24793 LONG DROP	10	12
OPK3610	10	1

## OPK

DN	5	6	8	10	12	16	19	25	31	38	51
Inch	3/16"	1/4"	5/16"	3/8"	1/2"	5/8"	3/4"	1"	1 1/4"	1 1/2"	2"
Size	-03	-04	-05	-06	-08	-10	-12	-16	-20	-24	-32

## FERRULES

OPK3610											
---------	--	--	--	--	--	--	--	--	--	--	--

## FITTINGS

BSP											
SAE (JIC)											
SAE (ORFS)											
SAE (O-RING BOSS)											
SAE (NPTF-NPSM)											
SAE FLANGE CODE 61											
SAE FLANGE CODE 62											
DIN METRIC 24° CONE LIGHT TYPE											
DIN METRIC 24° CONE HEAVY TYPE											
NF (FRENCH MILLIMETRIC TYPE)											
NF (FRENCH GAZ TYPE)											
JIS											
ORIGINAL EQUIPMENT CONNECTIONS											



## BS STANDARD CONNECTIONS

### OPK20512/OPK20513

BSP FEMALE 60° CONE - BS5200 / ISO 12151-6

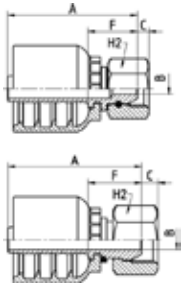

PART. REF.	HOSE BORE			Thread		DIMENSIONS mm						
	DN	Dash	inch			T	B	A	C	F	H2	
OPK20512-06A04	10	- 6	3/8"	1/4" - 19		4,1	47,5	4,2	18	19		
OPK20513-06A06	10	- 6	3/8"	3/8" - 19		7	49	6	19,5	22		
OPK20513-06A08	10	- 6	3/8"	1/2" - 14		9,3	49,5	6,3	20	27		
OPK20512-08A06	12	- 8	1/2"	3/8" - 19		7,1	52	6	21	22		
OPK20513-08A08	12	- 8	1/2"	1/2" - 14		9,3	51,5	6,3	20,5	27		
OPK20512-08A10	12	- 8	1/2"	5/8" - 14		12,1	53	10,2	22	28		
OPK20512-08A12	12	- 8	1/2"	3/4" - 14		15	56	9	24,5	32		
OPK20512-10A10	16	- 10	5/8"	5/8" - 14		12,5	56	10,2	21,5	28		
OPK20512-10A12	16	- 10	5/8"	3/4" - 14		15	57,5	9	23	32		
OPK20512-12A12	19	- 12	3/4"	3/4" - 14		15	61	9	24,5	32		
OPK20512-12A16	19	- 12	3/4"	1" - 11		19,8	62,5	10,5	26	38		
OPK20512-16A16	25	- 16	1"	1" - 11		19,8	75,5	10,5	27,5	38		

OPK20512: THRUST-WIRE NUT / OPK20513: SLIP-ON NUT

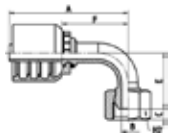
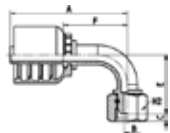

## BS STANDARD CONNECTIONS

### OPK20592/OPK20593

90° BSP FEMALE ELBOW 60° CONE - BS5200 /

PART. REF.	HOSE BORE			Thread		DIMENSIONS mm						
	DN	Dash	inch			T	B	A	C	E	F	H2
OPK20593-06A06	10	- 6	3/8"	3/8" - 19		7	66	6	31,5	36,5	22	
OPK20593-06A08	10	- 6	3/8"	1/2" - 14		9,3	66	6,3	32	36,5	27	
OPK20592-08A06	12	- 8	1/2"	3/8" - 19		7,1	76	6	41	45	22	
OPK20593-08A08	12	- 8	1/2"	1/2" - 14		9,3	76	6,3	36,5	45	27	
OPK20592-08A10	12	- 8	1/2"	5/8" - 14		12,1	75,5	10,2	44	44	28	
OPK20592-08A12	12	- 8	1/2"	3/4" - 14		15	75,5	9	45,5	44	32	
OPK20592-10A10	16	- 10	5/8"	5/8" - 14		12,5	88	10,2	53,5	53,5	28	
OPK20592-10A12	16	- 10	5/8"	3/4" - 14		15	88	9	55	53,5	32	
OPK20592-12A12	19	- 12	3/4"	3/4" - 14		15	98	9	59,5	61,5	32	
OPK20592-12A16	19	- 12	3/4"	1" - 11		19,8	98	10,5	62	61,5	38	
OPK20592-16A16	25	- 16	1"	1" - 11		19,8	127,5	10,5	76	79,5	38	

OPK20592: THRUST-WIRE NUT / OPK20593: SLIP-ON NUT

## BS STANDARD CONNECTIONS

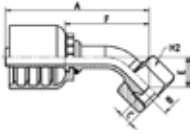
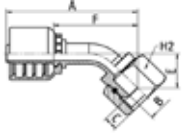

### OPK20542/OPK20543

45° BSP FEMALE ELBOW 60° CONE - BS5200 / ISO 12151-6

PART. REF.	HOSE BORE			Thread		DIMENSIONS mm						
	DN	Dash	inch			T	B	A	C	E	F	H2
OPK20543-06A06	10	- 6	3/8"	3/8" - 19		7	71,5	6	15,5	42	22	
OPK20543-06A08	10	- 6	3/8"	1/2" - 14		9,3	72	6,3	16	42,5	27	
OPK20543-08A08	12	- 8	1/2"	1/2" - 14		9,3	81	6,3	17	49,5	27	
OPK20542-08A10	12	- 8	1/2"	5/8" - 14		12,1	85,5	10,2	22,5	54,5	28	
OPK20542-10A10	16	- 10	5/8"	5/8" - 14		12,5	97,5	10,2	26	63	28	
OPK20542-10A12	16	- 10	5/8"	3/4" - 14		15	98	9	27	64	32	
OPK20542-12A12	19	- 12	3/4"	3/4" - 14		15	107	9	28,5	70,5	32	
OPK20542-12A16	19	- 12	3/4"	1" - 11		19,8	109	10,5	30	72,5	38	
OPK20542-16A16	25	- 16	1"	1" - 11		19,8	139,5	10,5	36,5	91	38	

OPK20542: THRUST-WIRE NUT / OPK20543: SLIP-ON NUT



## BS STANDARD CONNECTIONS

### OPK20812/OPK20813

BSP O-RING FEMALE 60° CONE - BS5200 / ISO 12151-6

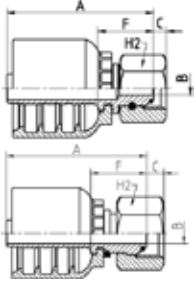

PART. REF.	HOSE BORE			Thread	DIMENSIONS mm						
	DN	Dash	inch		T	B	A	C	F	H2	
OPK20812-06A04	10	- 6	3/8"	1/4" - 19	4,1	47,5	4,1	18	19		
OPK20813-06A06	10	- 6	3/8"	3/8" - 19	7	49	6	19,5	22		
OPK20813-08A08	12	- 8	1/2"	1/2" - 14	9,3	51,5	6,3	20,5	27		
OPK20812-10A10	16	- 10	5/8"	5/8" - 14	12,5	56,5	9,7	22	28		
OPK20812-12A12	19	- 12	3/4"	3/4" - 14	15	61,5	8,5	25	32		
OPK20812-16A16	25	- 16	1"	1" - 11	19,8	75,5	10,6	27,5	38		
OPK20812-16A20	25	- 16	1"	1.1/4" - 11	26,1	79	10,5	31	50		
OPK20812-20A20	31	- 20	1.1/4"	1.1/4" - 11	26	84	10,5	31,5	50		
OPK20812-20A24	31	- 20	1.1/4"	1.1/2" - 11	32,1	82	12,5	29,5	60		
OPK20812-24A24	38	- 24	1.1/2"	1.1/2" - 11	32	92,5	12,5	30,5	60		
OPK20812-24A32	38	- 24	1.1/2"	2"	42,1	92	16,1	30	70		
OPK20812-32A32	51	- 32	2"	2"	42	98	16,1	32	70		

OPK20812: THRUST-WIRE NUT / OPK20813: SLIP-ON NUT

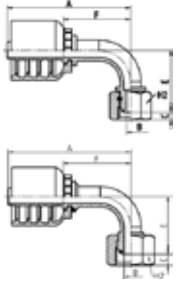

## BS STANDARD CONNECTIONS

### OPK20892/OPK20893

90° BSP O-RING FEMALE SWEPT ELBOW 60° CONE - BS5200 / ISO  
12151-6

PART. REF.	HOSE BORE			Thread	DIMENSIONS mm							
	DN	Dash	inch		T	B	A	C	E	F	H2	
OPK20892-06A04	10	- 6	3/8"	1/4" - 19		4,1	65	4,1	33	35,5	19	
OPK20893-06A06	10	- 6	3/8"	3/8" - 19		7	66	6	31,5	36,5	22	
OPK20893-08A08	12	- 8	1/2"	1/2" - 14		9,3	76	6,3	36,5	45	27	
OPK20892-10A10	16	- 10	5/8"	5/8" - 14		12,5	87,5	9,7	55	53	28	
OPK20892-12A12	19	- 12	3/4"	3/4" - 14		15	98	8,5	60	61,5	32	
OPK20892-16A16	25	- 16	1"	1" - 11		19,8	127,5	10,6	76	79,5	38	
OPK20892-16A20	25	- 16	1"	1.1/4" - 11		26,1	127,5	10,5	78,5	79,5	50	
OPK20892-20A20	31	- 20	1.1/4"	1.1/4" - 11		26	143	10,5	83,5	90,5	50	
OPK20892-20A24	31	- 20	1.1/4"	1.1/2" - 11		32,1	143	12,5	84,5	90,5	60	
OPK20892-24A24	38	- 24	1.1/2"	1.1/2" - 11		32	170	12,5	98,5	108	60	
OPK20892-32A32	51	- 32	2"	2" - 11		42	197	16,1	110,5	131	70	

OPK20892: THRUST-WIRE NUT / OPK20893: SLIP-ON NUT

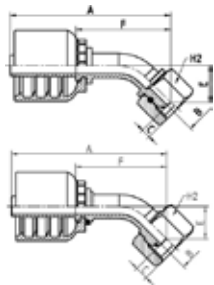

## BS STANDARD CONNECTIONS

### OPK20842/OPK20843

45° BSP O-RING FEMALE SWEEP ELBOW 60° CONE BS5200 / ISO  
12151-6

PART. REF.	HOSE BORE			Thread	DIMENSIONS mm						
	DN	Dash	inch		T	B	A	C	E	F	H2
OPK20843-06A06	10	- 6	3/8"	3/8" - 19	7	71,5	6	15,5	42	22	
OPK20843-08A08	12	- 8	1/2"	1/2" - 14	9,3	81	6,3	17	49,5	27	
OPK20842-10A10	16	- 10	5/8"	5/8" - 14	12,5	98	9,7	27,5	63,5	28	
OPK20842-12A12	19	- 12	3/4"	3/4" - 14	15	107,5	8,5	29	71	32	
OPK20842-16A16	25	- 16	1"	1" - 11	19,8	138,5	10,6	35,5	90,5	38	
OPK20842-20A20	31	- 20	1.1/4"	1.1/4" - 11	26	154	10,5	39	101,5	50	
OPK20842-24A24	38	- 24	1.1/2"	1.1/2" - 11	32	180	12,5	45	118	60	
OPK20842-32A32	51	- 32	2"	2" - 11	42	200	16,1	47	134	70	

OPK20842: THRUST-WIRE NUT / OPK20843: SLIP-ON NUT

## SAE STANDARD CONNECTIONS

### OPK12510

JIC MALE 37° CONE - SAE J516 / ISO 12151-5

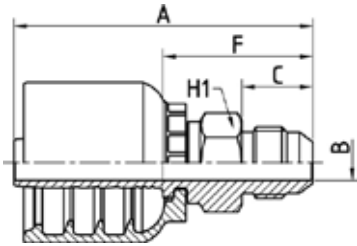

PART. REF.	HOSE BORE			Thread	DIMENSIONS mm							
	DN	Dash	inch		T	B	A	C	F	H1		
OPK12510-06A06	10	- 6	3/8"	9/16" - 18		7	59	14	29,5	17		
OPK12510-06A08	10	- 6	3/8"	3/4" - 16		9,3	63,5	16,5	34	19		
OPK12510-06A10	10	- 6	3/8"	7/8" - 14		12,5	68	19,5	38,5	24		
OPK12510-08A06	12	- 8	1/2"	9/16" - 18		7	63	14	32	19		
OPK12510-08A08	12	- 8	1/2"	3/4" - 16		9,3	65,5	16,5	34,5	19		
OPK12510-08A10	12	- 8	1/2"	7/8" - 14		12,5	70	19,5	39	24		
OPK12510-08A12	12	- 8	1/2"	1.1/16" - 12		15	74	22	43	27		
OPK12510-10A10	16	- 10	5/8"	7/8" - 14		12,5	73,5	19,5	39	24		
OPK12510-10A12	16	- 10	5/8"	1.1/16" - 12		15	77	22	42,5	27		
OPK12510-12A10	19	- 12	3/4"	7/8" - 14		12,5	78	19,5	41,5	27		
OPK12510-12A12	19	- 12	3/4"	1.1/16" - 12		15	80,5	22	44	27		
OPK12510-12A14	19	- 12	3/4"	1.3/16" - 12		15	81	22,5	44,5	32		
OPK12510-12A16	19	- 12	3/4"	1.5/16" - 12		19,8	83,5	23	47	34		
OPK12510-16A12	25	- 16	1"	1.1/16" - 12		15	93	22	45	32		
OPK12510-16A16	25	- 16	1"	1.5/16" - 12		19,8	96	23	48	34		
OPK12510-16A20	25	- 16	1"	1.5/8" - 12		26	101	24,3	53	42		
OPK12510-20A20	31	- 20	1.1/4"	1.5/8" - 12		26	106	24,3	53,5	42		
OPK12510-20A24	31	- 20	1.1/4"	1.7/8" - 12		32	113	27,5	60,5	50		
OPK12510-24A24	38	- 24	1.1/2"	1.7/8" - 12		32	122,5	27,5	60,5	50		
OPK12510-32A32	51	- 32	2"	2.1/2" - 12		42	138	34	72	65		

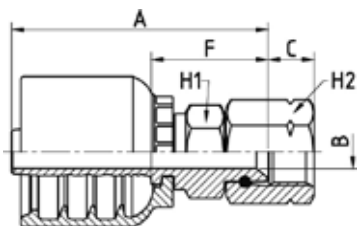

## SAE STANDARD CONNECTIONS

### OPK22712

JIC FEMALE 37° CONE SEAT DOUBLE HEXAGON SAE J516 / ISO 12151-5 (THRUST-WIRE NUT)

PART. REF.	HOSE BORE			Thread	DIMENSIONS mm							
	DN	Dash	inch		T	B	A	C	F	H1	H2	
OPK22712-12A16	19	- 12	3/4"	1.5/16" - 12		19,8	69	15	32,5	32	38	
OPK22712-16A20	25	- 16	1"	1.5/8" - 12		26	91	16,2	43	41	50	
OPK22712-20A20	31	- 20	1.1/4"	1.5/8" - 12		26	96	16,2	43,5	41	50	
OPK22712-24A24	38	- 24	1.1/2"	1.7/8" - 12		32	113	18,8	51	50	60	
OPK22712-32A32	51	- 32	2"	2.1/2" - 12		44	117,5	24	51,5	65	75	

## SAE STANDARD CONNECTIONS

### OPK22711/OPK22711KR

JIC FEMALE 37° CONE SEAT DOUBLE HEXAGON - SAE J516 / ISO 12151-5

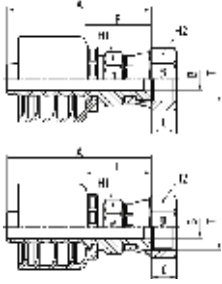

PART. REF.	HOSE BORE			Thread	DIMENSIONS mm							
	DN	Dash	inch		T	B	A	C	F	H1	H2	
OPK22711-06A06KR	10	- 6	3/8"	9/16" - 18	7	51,5	9,5	22	17	17		
OPK22711-06A08KR	10	- 6	3/8"	3/4" - 16	9,3	56	10,7	26,5	19	22		
OPK22711-08A08KR	12	- 8	1/2"	3/4" - 16	9,3	58	10,7	27	19	22		
OPK22711-08A10KR	12	- 8	1/2"	7/8" - 14	9,3	60,5	12,5	29,5	22	25		
OPK22711-08A12KR	12	- 8	1/2"	1.1/16" - 12	15	60	14,1	28,5	27	32		
OPK22711-10A08KR	16	- 10	5/8"	3/4" - 16	9,3	62,5	10,7	28,5	22	22		
OPK22711-10A10KR	16	- 10	5/8"	7/8" - 14	12,5	64	12,5	29,5	22	25		
OPK22711-12A08KR	19	- 12	3/4"	3/4" - 16	9,3	66	10,7	29,5	27	22		
OPK22711-12A10KR	19	- 12	3/4"	7/8" - 14	12,5	67	12,5	30,5	27	25		
OPK22711-12A12KR	19	- 12	3/4"	1.1/16" - 12	15	66,5	14,1	30	27	32		
OPK22711-12A16	19	- 12	3/4"	1.5/16" - 12	19,8	71	15,3	34,5	32	38		
OPK22711-16A12KR	25	- 16	1"	1.1/16" - 12	15	80,5	14,1	32,5	32	32		
OPK22711-16A16	25	- 16	1"	1.5/16" - 12	19,8	83,5	15,3	35,5	32	38		

KR:CRIMPED-BACK KOMPACT ROBUST NUT

## SAE STANDARD CONNECTIONS

### OPK22592/OPK22593

90° JIC FEMALE SWEPT ELBOW 37° CONE SEAT - SAE J516 / ISO  
12151-5

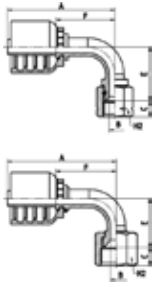

FITTINGS  
F 10-10

PART. REF.	HOSE BORE			Thread	DIMENSIONS mm							
	DN	Dash	inch		T	B	A	C	E	F	H2	
OPK22592-06A05	10	- 6	3/8"	1/2" - 20		5,5	59,5	9,1	26,5	30	17	
OPK22592-06A06	10	- 6	3/8"	9/16" - 18		7	65	9,2	32,5	35,5	19	
OPK22593-06A08	10	- 6	3/8"	3/4" - 16		7	66	10,1	29,5	36,5	22	
OPK22593-06A10	10	- 6	3/8"	7/8" - 14		9,3	66	12,4	31,5	36,5	27	
OPK22592-08A06	12	- 8	1/2"	9/16" - 18		7	68	9,2	33	37	19	
OPK22592-08A08	12	- 8	1/2"	3/4" - 16		9,3	75,5	10,2	41	44	22	
OPK22593-08A10	12	- 8	1/2"	7/8" - 14		9,3	76	12,4	36	45	27	
OPK22593-08A12	12	- 8	1/2"	1.1/16" - 12		12,5	76	14,1	36	45	32	
OPK22592-10A10	16	- 10	5/8"	7/8" - 14		12,5	88	12,3	52,5	53,5	27	
OPK22593-10A12	16	- 10	5/8"	1.1/16" - 12		12,5	86	14,1	50	51,5	32	
OPK22592-12A10	19	- 12	3/4"	7/8" - 14		12,5	91,5	12,3	52,5	55	27	
OPK22592-12A12	19	- 12	3/4"	1.1/16" - 12		15	98	14,2	58	62	32	
OPK22592-12A14	19	- 12	3/4"	1.3/16" - 12		15	99	14,3	58	63	36	
OPK22592-12A16	19	- 12	3/4"	1.5/16" - 12		19,8	99	15	57,5	63	38	
OPK22592-16A16	25	- 16	1"	1.5/16" - 12		19,8	124	15	68,5	76	38	
OPK22592-16A20	25	- 16	1"	1.5/8" - 12		26	125,5	16,2	74,5	77,5	50	
OPK22592-20A20	31	- 20	1.1/4"	1.5/8" - 12		26	143	16,2	86,5	90,5	50	
OPK22592-20A24	31	- 20	1.1/4"	1.7/8" - 12		32	143	18,8	90,5	90,5	60	
OPK22592-24A24	38	- 24	1.1/2"	1.7/8" - 12		32	170	18,8	100,5	108	60	
OPK22592-32A32	51	- 32	2"	2.1/2" - 12		44	208	24	137	142	75	

OPK22592: THRUST-WIRE NUT / OPK22593: SLIP-ON NUT

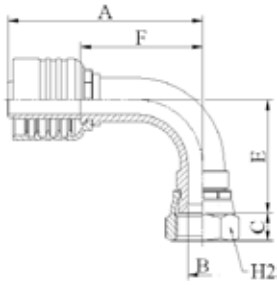

## SAE STANDARD CONNECTIONS

### OPK22591KR

90° ELBOW JIC FEMALE 37° CONE SEAT SAE J516 / ISO 12151-5  
(CRIMPED-BACK NUT)

PART. REF.	HOSE BORE			Thread		DIMENSIONS mm						
	DN	Dash	inch			T	B	A	C	E	F	H2
OPK22591-06A06KR	10	- 6	3/8"	9/16" - 18		7	65	9,5	32	35,5	17	
OPK22591-08A08KR	12	- 8	1/2"	3/4" - 16		9,3	75,5	10,7	40,5	44	22	
OPK22591-10A10KR	16	- 10	5/8"	7/8" - 14		12,5	88	12,5	47	53,5	25	
OPK22591-12A12KR	19	- 12	3/4"	1.1/16" - 12		15	98	14,1	57	62	32	

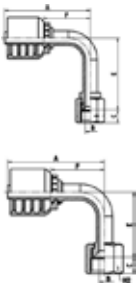

## SAE STANDARD CONNECTIONS

### OPK24792/OPK24793 LONG DROP

90° JIC FEMALE LONG DROP ELBOW 37° CONE SEAT - SAE J516 / ISO  
12151-5

PART. REF.	HOSE BORE			Thread		DIMENSIONS mm						
	DN	Dash	inch			T	B	A	C	E	F	H2
OPK24792-06A06	10	- 6	3/8"	9/16" - 18		7	65	9,2	55	35,5	19	
OPK24793-06A08	10	- 6	3/8"	3/4" - 16		7	66	10,1	61,5	36,5	22	
OPK24792-08A08	12	- 8	1/2"	3/4" - 16		9,3	75,5	10,2	61	44	22	
OPK24793-08A10	12	- 8	1/2"	7/8" - 14		9,3	76	12,4	65	45	27	
OPK24792-10A10	16	- 10	5/8"	7/8" - 14		12,5	88	12,3	65,5	53,5	27	
OPK24792-12A12	19	- 12	3/4"	1.1/16" - 12		15	98	14,2	94,5	62	32	
OPK24792-16A16	25	- 16	1"	1.5/16" - 12		19,8	125,5	15	110	77,5	38	

OPK24792: THRUST-WIRE NUT / OPK24793: SLIP-ON NUT

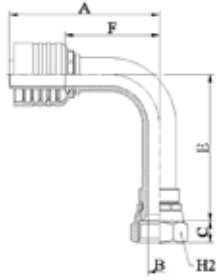

## SAE STANDARD CONNECTIONS

### OPK24791KR

**90° LONG DROP ELBOW JIC FEMALE 37° CONE SEAT SAE J516 / ISO 12151-5 (CRIMPED-BACK NUT)**

PART. REF.	HOSE BORE			Thread	DIMENSIONS mm						
	DN	Dash	inch		T	B	A	C	E	F	H2
OPK24791-06A06KR	10	- 6	3/8"	9/16" - 18	7	65	9,5	55	35,5	17	
OPK24791-08A08KR	12	- 8	1/2"	3/4" - 16	9,3	75,5	10,7	64	44	22	
OPK24791-10A10KR	16	- 10	5/8"	7/8" - 14	12,5	88	12,5	70	53,5	25	
OPK24791-12A12KR	19	- 12	3/4"	1.1/16" - 12	15	98	14,1	96	62	32	

FITTINGS  
F 10-12

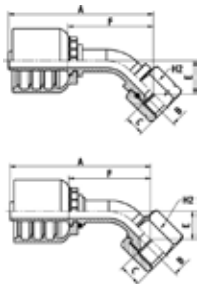

## SAE STANDARD CONNECTIONS

### OPK22542/OPK22543

**45° JIC FEMALE SWEEP ELBOW 37° CONE SEAT - SAE J516 / ISO 12151-5**

PART. REF.	HOSE BORE			Thread	DIMENSIONS mm						
	DN	Dash	inch		T	B	A	C	E	F	H2
OPK22542-06A06	10	- 6	3/8"	9/16" - 18	7	71,5	9,2	16,5	42	19	
OPK22543-06A08	10	- 6	3/8"	3/4" - 16	7	70,5	10,1	14	41	22	
OPK22543-06A10	10	- 6	3/8"	7/8" - 14	9,3	72	12,4	15,5	42,5	27	
OPK22542-08A08	12	- 8	1/2"	3/4" - 16	9,3	83	10,2	20	52	22	
OPK22543-08A10	12	- 8	1/2"	7/8" - 14	9,3	80,5	12,4	17	49,5	27	
OPK22543-08A12	12	- 8	1/2"	1.1/16" - 12	12,5	80,5	14,1	17	49,5	32	
OPK22542-10A10	16	- 10	5/8"	7/8" - 14	12,5	96,5	12,3	25,5	62	27	
OPK22543-10A12	16	- 10	5/8"	1.1/16" - 12	12,5	94,5	14,1	24	60	32	
OPK22542-12A12	19	- 12	3/4"	1.1/16" - 12	15	106	14,2	27,5	70	32	
OPK22542-12A14	19	- 12	3/4"	1.3/16" - 12	15	106	14,3	27,5	69,5	36	
OPK22542-12A16	19	- 12	3/4"	1.5/16" - 12	19,8	106,5	15	27,5	70	38	
OPK22542-16A16	25	- 16	1"	1.5/16" - 12	19,8	132,5	15	32	84	38	
OPK22542-16A20	25	- 16	1"	1.5/8" - 12	26	138	16,2	36	90	50	
OPK22542-20A20	31	- 20	1.1/4"	1.5/8" - 12	26	156	16,2	41,5	103,5	50	
OPK22542-20A24	31	- 20	1.1/4"	1.7/8" - 12	32	159	18,8	44,5	106,5	60	
OPK22542-24A24	38	- 24	1.1/2"	1.7/8" - 12	32	181	18,8	46,5	119	60	
OPK22542-32A32	51	- 32	2"	2.1/2" - 12	44	229	24	68	163	75	

OPK22542: THRUST-WIRE NUT / OPK22543: SLIP-ON NUT



## SAE STANDARD CONNECTIONS

### OPK22541KR

45° ELBOW JIC FEMALE 37° CONE SEAT SAE J516 / ISO 12151-5  
(CRIMPED-BACK NUT)

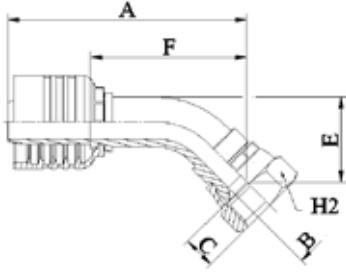

PART. REF.	HOSE BORE			Thread		DIMENSIONS mm						
	DN	Dash	inch			T	B	A	C	E	F	H2
OPK22541-06A06KR	10	- 6	3/8"	9/16" - 18		7	71,5	9,5	16	42	17	
OPK22541-08A08KR	12	- 8	1/2"	3/4" - 16		9,3	83	10,7	20	52	22	
OPK22541-10A10KR	16	- 10	5/8"	7/8" - 14		12,5	95,5	12,5	22,5	61	25	
OPK22541-12A12KR	19	- 12	3/4"	1.1/16" - 12		15	105,5	14,1	26,5	69	32	

## SAE STANDARD CONNECTIONS

### OPK12410

ORFS MALE - SAE J516 / ISO 12151-1

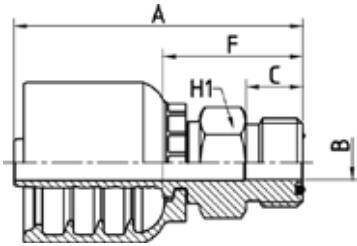

PART. REF.	HOSE BORE			Thread	DIMENSIONS mm						
	DN	Dash	inch		T	B	A	C	F	H1	
OPK12410-06A06	10	- 6	3/8"	11/16" - 16	6,7	57	11,2	27,5	19		
OPK12410-06A08	10	- 6	3/8"	13/16" - 16	9,3	59,5	12,8	30	22		
OPK12410-08A08	12	- 8	1/2"	13/16" - 16	9,3	61,5	12,8	30,5	22		
OPK12410-08A10	12	- 8	1/2"	1" - 14	12,5	66	15,5	35	27		
OPK12410-10A10	16	- 10	5/8"	1" - 14	12,5	69	15,5	34,5	27		
OPK12410-10A12	16	- 10	5/8"	1.3/16" - 12	15	72	17	37,5	32		
OPK12410-12A12	19	- 12	3/4"	1.3/16" - 12	15	75,5	17	39	32		
OPK12410-12A16	19	- 12	3/4"	1.7/16" - 12	19,8	77	17,5	40,5	38		
OPK12410-16A16	25	- 16	1"	1.7/16" - 12	19,8	90	17,5	42	38		
OPK12410-20A20	31	- 20	1.1/4"	1.11/16" - 12	26	99	17,5	46,5	46		
OPK12410-24A24	38	- 24	1.1/2"	2" - 12	32	110,5	17,5	48,5	55		

## SAE STANDARD CONNECTIONS

### OPK22411

ORFS FEMALE - SAE J516 / ISO 12151-1 PULLBACK TYPE

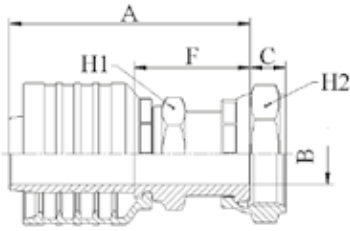

PART. REF.	HOSE BORE			Thread	DIMENSIONS mm						
	DN	Dash	inch		T	B	A	C	F	H1	H2
OPK22411-06A06	10	-6	3/8"	11/16" - 16	7	60,5	9,5	31	16	22	
OPK22411-06A08	10	-6	3/8"	13/16" - 16	9,3	65	11	35,5	19	24	
OPK22411-08A06	12	-8	1/2"	11/16" - 16	7	63	9,5	32	19	22	
OPK22411-08A08	12	-8	1/2"	13/16" - 16	9,3	67	11	36	19	24	
OPK22411-08A10	12	-8	1/2"	1" - 14	11,5	69,5	13,5	38,5	24	30	
OPK22411-08A12	12	-8	1/2"	1.3/16" - 12	13,9	73	14,5	42	28	36	
OPK22411-10A10	16	-10	5/8"	1" - 14	11,5	73	13,5	38,5	24	30	
OPK22411-10A12	16	-10	5/8"	1.3/16" - 12	13,9	76,5	14,5	42	28	36	
OPK22411-12A10	19	-12	3/4"	1" - 14	11,5	77,5	13,5	41	28	30	
OPK22411-12A12	19	-12	3/4"	1.3/16" - 12	13,9	80	14,5	43,5	28	36	
OPK22411-12A16	19	-12	3/4"	1.7/16" - 12	19,8	82	15	45,5	36	41	
OPK22411-16A12	25	-16	1"	1.3/16" - 12	13,9	94	13,5	48	36	36	
OPK22411-16A16	25	-16	1"	1.7/16" - 12	19,8	94,5	15	46,5	36	41	
OPK22411-16A20	25	-16	1"	1.11/16" - 12	26	97,5	14,8	49,5	41	50	
OPK22411-20A20	31	-20	1.1/4"	1.11/16" - 12	26	101,5	14,8	49	41	50	
OPK22411-24A24	38	-24	1.1/2"	2" - 12	32	116	15,8	54	50	60	

## SAE STANDARD CONNECTIONS

### OPK22491/OPK22493

90° ORFS FEMALE ELBOW - SAE J516 / ISO 12151-1

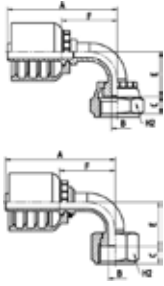

PART. REF.	HOSE BORE			Thread	DIMENSIONS mm						
	DN	Dash	inch		T	B	A	C	E	F	H2
OPK22493-06A06	10	- 6	3/8"	11/16" - 16	6	59,5	9,5	24	30	22	
OPK22493-06A08	10	- 6	3/8"	13/16" - 16	9,3	59,5	11	26,5	30	24	
OPK22491-08A06	12	- 8	1/2"	11/16" - 16	7	61,5	9,5	24,5	30	22	
OPK22493-08A08	12	- 8	1/2"	13/16" - 16	9	71,5	11	30	40,5	24	
OPK22493-08A10	12	- 8	1/2"	1" - 14	11,5	71	13,5	30,5	40	30	
OPK22493-08A12	12	- 8	1/2"	1.3/16" - 12	13,9	71	14,5	37,5	39,5	36	
OPK22493-10A10	16	- 10	5/8"	1" - 14	11,5	82,5	13,5	37,5	48	30	
OPK22493-10A12	16	- 10	5/8"	1.3/16" - 12	13,9	82,5	14,5	41	48	36	
OPK22491-12A10	19	- 12	3/4"	1" - 14	11,5	85,5	13,5	38	49	30	
OPK22493-12A12	19	- 12	3/4"	1.3/16" - 12	13,9	93	14,5	48	56,5	36	
OPK22493-12A16	19	- 12	3/4"	1.7/16" - 12	19,8	93	14,8	47,5	56,5	41	
OPK22491-16A12	25	- 16	1"	1.3/16" - 12	13,9	106	14,5	48	57,5	36	
OPK22493-16A16	25	- 16	1"	1.7/16" - 12	19,8	119,5	14,8	56	71,5	41	
OPK22493-16A20	25	- 16	1"	1.11/16" - 12	26	119,5	14,8	58,5	71,5	50	
OPK22493-20A20	31	- 20	1.1/4"	1.11/16" - 12	26	135,5	14,8	66	83	50	
OPK22493-24A24	38	- 24	1.1/2"	2" - 12	32	164	14,8	79,5	102	60	

OPK22491: CRIMPED BACK-NUT / OPK22493: SLIP-ON NUT

## SAE STANDARD CONNECTIONS

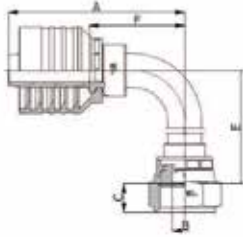

### OPK24491 LONG DROP

90° ORFS FEMALE LONG DROP ELBOW - SAE J516 / ISO 12151-1  
(CRIMPED-BACK NUT)

PART. REF.	HOSE BORE			Thread		DIMENSIONS mm						
	DN	Dash	inch			T	B	A	C	E	F	H2
OPK24491-06A06	10	- 6	3/8"	11/16" - 16		6,7	61,5	9,5	54	32	22	
OPK24491-06A08	10	- 6	3/8"	13/16" - 16		6,7	61,5	11	54	32	24	
OPK24491-08A08	12	- 8	1/2"	13/16" - 16		9,6	68	11	64	37	24	
OPK24491-08A10	12	- 8	1/2"	1" - 14		9,6	68	12,5	64,5	37	30	
OPK24491-10A10	16	- 10	5/8"	1" - 14		12	75,5	13	70	41	30	
OPK24491-10A12	16	- 10	5/8"	1.3/16" - 12		12,7	75,5	13,5	73	41	36	
OPK24491-12A12	19	- 12	3/4"	1.3/16" - 12		15	95	13,5	96	58,5	36	
OPK24491-16A16	25	- 16	1"	1.7/16" - 12		19,8	119,5	13,5	114	71,5	41	

All items are made from brazing with the exception of OPK24491-12-12 and OPK24491-16-16

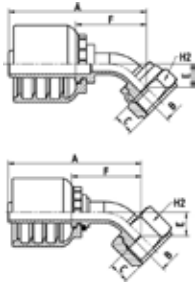

## SAE STANDARD CONNECTIONS

### OPK22441/OPK22443

45° ORFS FEMALE ELBOW - SAE J516 / ISO 12151-1

PART. REF.	HOSE BORE			Thread	DIMENSIONS mm						
	DN	Dash	inch		T	B	A	C	E	F	H2
OPK22443-06A06	10	- 6	3/8"	11/16" - 16	6	61,5	9,5	11	32,5	22	
OPK22443-06A08	10	- 6	3/8"	13/16" - 16	9,3	63	11	12,5	34	24	
OPK22441-08A06	12	- 8	1/2"	11/16" - 16	7	63,5	9,5	11	32,5	22	
OPK22443-08A08	12	- 8	1/2"	13/16" - 16	9	73	11	13	42	24	
OPK22443-08A10	12	- 8	1/2"	1" - 14	11,5	73	13,5	13,5	42	30	
OPK22443-08A12	12	- 8	1/2"	1.3/16" - 12	13,9	78	14,5	18,5	46,5	36	
OPK22443-10A10	16	- 10	5/8"	1" - 14	11,5	83,5	13,5	16	49	30	
OPK22443-10A12	16	- 10	5/8"	1.3/16" - 12	13,9	86	14,5	18,5	51,5	36	
OPK22441-12A10	19	- 12	3/4"	1" - 14	11,5	87	13,5	16,5	50,5	30	
OPK22443-12A12	19	- 12	3/4"	1.3/16" - 12	13,9	97	14,5	21,5	60,5	36	
OPK22443-12A16	19	- 12	3/4"	1.7/16" - 12	19,8	96,5	14,8	21	60	41	
OPK22443-16A16	25	- 16	1"	1.7/16" - 12	19,8	120	14,8	23,5	72	41	
OPK22443-16A20	25	- 16	1"	1.11/16" - 12	26	122	14,8	25	74	50	
OPK22443-20A20	31	- 20	1.1/4"	1.11/16" - 12	26	134,5	14,8	27	82	50	
OPK22443-24A24	38	- 24	1.1/2"	2" - 12	32	160	14,8	31,5	98	60	

OPK22441: CRIMPED BACK-NUT / OPK22443: SLIP-ON NUT

## SAE STANDARD CONNECTIONS

### OPK13010

SAE MALE O'RING BOSS TYPE

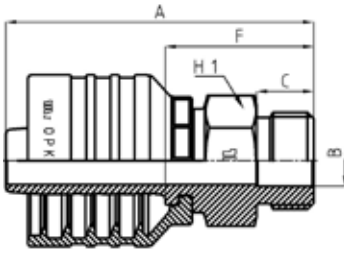

PART. REF.	HOSE BORE			Thread	DIMENSIONS mm							
	DN	Dash	inch		T	B	A	C	F	H1		
OPK13010-08A08	12	- 8	1/2"	3/4" - 16		9,9	60	11,1	29	22		
OPK13010-12A12	19	- 12	3/4"	1.1/16" - 12		15,5	76	15,1	39,5	32		
OPK13010-16A16	25	- 16	1"	1.5/16" - 12		21,5	89,5	15,1	41	38		

## SAE STANDARD CONNECTIONS

### OPK14310

SAE SWIVEL MALE O'RING BOSS TYPE

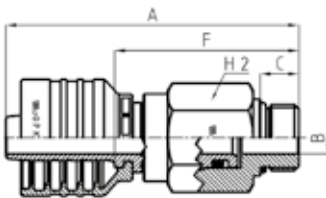

PART. REF.	HOSE BORE			Thread	DIMENSIONS mm							
	DN	Dash	inch		T	B	A	C	F	H2		
OPK14310-08A08	12	- 8	1/2"	3/4" - 16		9,3	84	11,1	53	27		

Not to be used as a live swivel

## SAE STANDARD CONNECTIONS

### OPK12810

NPTF MALE 60° CONE SEAT - SAE J516/J514

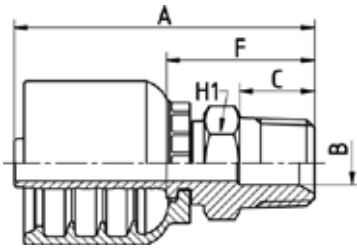

PART. REF.	HOSE BORE			Thread	DIMENSIONS mm						
	DN	Dash	inch		T	B	A	C	F	H1	
OPK12810-06A04	10	- 6	3/8"	1/4" - 18	5,5	59,5	14,5	30	14		
OPK12810-06A06	10	- 6	3/8"	3/8" - 18	9,3	58	14,5	28,5	19		
OPK12810-06A08	10	- 6	3/8"	1/2" - 14	12,5	64	19,2	34,5	24		
OPK12810-08A06	12	- 8	1/2"	3/8" - 18	9,3	60	14,5	29	19		
OPK12810-08A08	12	- 8	1/2"	1/2" - 14	12,5	66	19,2	35	24		
OPK12810-08A12	12	- 8	1/2"	3/4" - 14	15,5	66,5	19,2	35,5	27		
OPK12810-10A08	16	- 10	5/8"	1/2" - 14	12,5	73	19,2	38,5	24		
OPK12810-10A12	16	- 10	5/8"	3/4" - 14	16	74,5	19,2	40	27		
OPK12810-12A08	19	- 12	3/4"	1/2" - 14	12,5	73	19,2	36,5	27		
OPK12810-12A12	19	- 12	3/4"	3/4" - 14	16	73	19,2	36,5	27		
OPK12810-12A16	19	- 12	3/4"	1" - 11,5	19,8	82,5	24,2	46	36		
OPK12810-16A12	25	- 16	1"	3/4" - 14	15,5	87	19,2	39	32		
OPK12810-16A16	25	- 16	1"	1" - 11,5	19,8	92	24,2	44	36		
OPK12810-16A20	25	- 16	1"	1.1/4" - 11,5	26	104,5	25	56,5	46		
OPK12810-20A20	31	- 20	1.1/4"	1.1/4" - 11,5	26	109	25	56,5	46		
OPK12810-24A24	38	- 24	1.1/2"	1.1/2" - 11,5	32	119,5	26	57,5	50		
OPK12810-32A32	51	- 32	2"	2" - 11,5	45	130,5	26,5	64,5	65		



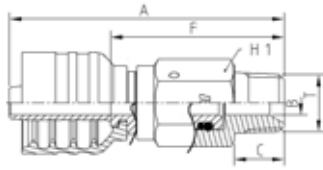

## SAE STANDARD CONNECTIONS

### OPK14110R

NPTF SWIVEL MALE 60° CONE SEAT - SAE J516/J514

PART. REF.	HOSE BORE			Thread	DIMENSIONS mm						
	DN	Dash	inch		T	B	A	C	F	H1	
OPK14110-06A06R	10	- 6	3/8"	3/8" - 18	7	80	14,5	50,5	22		
OPK14110-08A08R	12	- 8	1/2"	1/2" - 14	9,3	90	19,2	59	27		
OPK14110-12A12R	19	- 12	3/4"	3/4" - 14	16	94,5	19,2	58	32		
OPK14110-16A16R	25	- 16	1"	1" - 11,5	19,8	114	24,2	66	38		

Not to be used as a live swivel

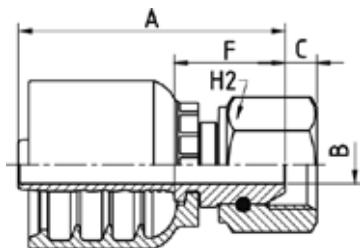

## SAE STANDARD CONNECTIONS

### OPK22812

NPSM FEMALE 60° CONE - SAE J516/J514 (THRUST-WIRE NUT)

PART. REF.	HOSE BORE			Thread	DIMENSIONS mm						
	DN	Dash	inch		T	B	A	C	F	H2	
OPK22812-06A06	10	- 6	3/8"	3/8" - 18	7	50,5	6	21	22		
OPK22812-08A08	12	- 8	1/2"	1/2" - 14	9,3	54	6,5	23	27		
OPK22812-12A12	19	- 12	3/4"	3/4" - 14	15	61	9	24,5	32		
OPK22812-16A16	25	- 16	1"	1" - 11,5	19,8	75,5	10,5	27,5	38		

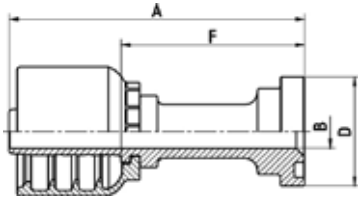

## SAE STANDARD CONNECTIONS

### OPK23311

ISO/SAE CODE 61 FLANGE - SAE J516 / ISO 12151-3

PART. REF.	HOSE BORE			Flange	DIMENSIONS mm						
	DN	Dash	inch		Inch	B	A	D	F		
OPK23311-08A08	12	- 8	1/2"	1/2"	9,3	82	30,3	51			
OPK23311-08A12	12	- 8	1/2"	3/4"	15,1	89	38	58			
OPK23311-10A12	16	- 10	5/8"	3/4"	15	100	38	65,5			
OPK23311-12A12	19	- 12	3/4"	3/4"	15	94,5	38	58			
OPK23311-12A16	19	- 12	3/4"	1"	20	94,5	44,6	58			
OPK23311-16A16	25	- 16	1"	1"	19,8	112,5	44,6	64,5			
OPK23311-16A20	25	- 16	1"	1.1/4"	26	118,5	51	70,5			
OPK23311-20A20	31	- 20	1.1/4"	1.1/4"	26	123	51	70,5			
OPK23311-20A24	31	- 20	1.1/4"	1.1/2"	32	125	60,5	72,5			
OPK23311-24A24	38	- 24	1.1/2"	1.1/2"	32	137,5	60,5	75,5			
OPK23311-24A32	38	- 24	1.1/2"	2"	42	137,5	71,6	75,5			
OPK23311-32A32	51	- 32	2"	2"	42	145	71,6	79			
OPK23311-32A40	51	- 32	2"	2.1/2"	56	147	84,3	81			

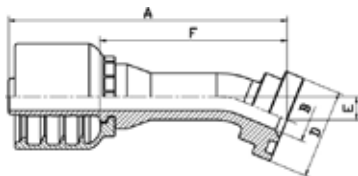

## SAE STANDARD CONNECTIONS

### OPK23321

22,5° ISO/SAE CODE 61 FLANGE - SAE J516 / ISO 12151-3

PART. REF.	HOSE BORE			Flange	DIMENSIONS mm						
	DN	Dash	inch		Inch	B	A	D	E	F	
OPK23321-08A08	12	- 8	1/2"	1/2"	9,3	95	30,3	8	64		
OPK23321-12A12	19	- 12	3/4"	3/4"	15	111	38	10	74,5		
OPK23321-12A16	19	- 12	3/4"	1"	20	111	44,6	10	74,5		
OPK23321-16A16	25	- 16	1"	1"	19,8	137	44,6	11,5	89		
OPK23321-20A20	31	- 20	1.1/4"	1.1/4"	26	152,5	51	12	100		
OPK23321-20A24	31	- 20	1.1/4"	1.1/2"	32	154,5	60,5	13	102		

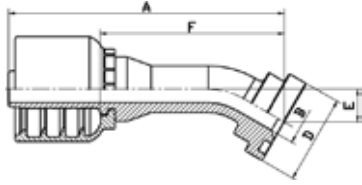

## SAE STANDARD CONNECTIONS

### OPK23331

30° ISO/SAE CODE 61 FLANGE - SAE J516 / ISO 12151-3

PART. REF.	HOSE BORE			Flange	DIMENSIONS mm						
	DN	Dash	inch		Inch	B	A	D	E	F	
OPK23331-08A08	12	- 8	1/2"	1/2"	9,3	93,5	30,3	11	62,5		
OPK23331-12A12	19	- 12	3/4"	3/4"	15	109,5	38	14	73		
OPK23331-12A16	19	- 12	3/4"	1"	20	109,5	44,6	14	73		
OPK23331-16A16	25	- 16	1"	1"	19,8	135	44,6	16,5	87		
OPK23331-20A20	31	- 20	1.1/4"	1.1/4"	26	150,5	51	17,5	98		
OPK23331-24A24	38	- 24	1.1/2"	1.1/2"	32	176,5	60,5	20	114,5		

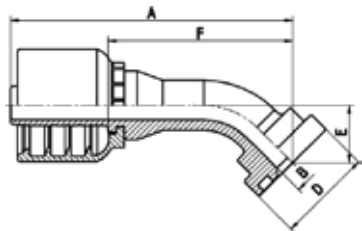

## SAE STANDARD CONNECTIONS

### OPK23341

45° ISO/SAE CODE 61 FLANGE - SAE J516 / ISO 12151-3

PART. REF.	HOSE BORE			Flange	DIMENSIONS mm						
	DN	Dash	inch		Inch	B	A	D	E	F	
OPK23341-08A08	12	- 8	1/2"	1/2"	9,3	90	30,3	18,5	58,5		
OPK23341-08A12	12	- 8	1/2"	3/4"	15	90,5	38	19	59,5		
OPK23341-10A12	16	- 10	5/8"	3/4"	15	95	38	22	61		
OPK23341-12A12	19	- 12	3/4"	3/4"	15	104,5	38	23	68,5		
OPK23341-12A16	19	- 12	3/4"	1"	20	104,5	44,6	23	68,5		
OPK23341-16A16	25	- 16	1"	1"	19,8	129,5	44,6	27,5	81,5		
OPK23341-16A20	25	- 16	1"	1.1/4"	26	129,5	51	27,5	81,5		
OPK23341-20A20	31	- 20	1.1/4"	1.1/4"	26	144,5	51	29,5	92		
OPK23341-20A24	31	- 20	1.1/4"	1.1/2"	32	146	60,5	31	93,5		
OPK23341-24A24	38	- 24	1.1/2"	1.1/2"	32	169,5	60,5	34,5	107,5		
OPK23341-24A32	38	- 24	1.1/2"	2"	42	169,5	71,6	34,5	107,5		
OPK23341-32A32	51	- 32	2"	2"	42	190	71,6	39	124		

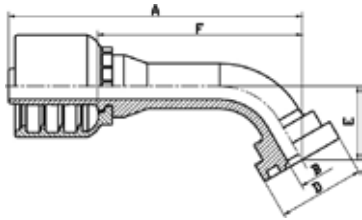

## SAE STANDARD CONNECTIONS

### OPK23361

60° ISO/SAE CODE 61 FLANGE - SAE J516 / ISO 12151-3

PART. REF.	HOSE BORE			Flange	DIMENSIONS mm						
	DN	Dash	inch		Inch	B	A	D	E	F	
OPK23361-08A08	12	- 8	1/2"	1/2"	9,3	102,5	30,3	26	71,5		
OPK23361-12A12	19	- 12	3/4"	3/4"	15	123,5	38	33	87		
OPK23361-16A16	25	- 16	1"	1"	19,8	152	44,6	39	104		
OPK23361-16A20	25	- 16	1"	1.1/4"	26	152	51	39	104		
OPK23361-20A20	31	- 20	1.1/4"	1.1/4"	26	172,5	51	43	120		
OPK23361-20A24	31	- 20	1.1/4"	1.1/2"	32	173,5	60,5	44,5	121		
OPK23361-24A24	38	- 24	1.1/2"	1.1/2"	32	205,5	60,5	50,5	143,5		

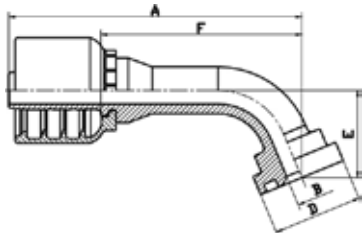

## SAE STANDARD CONNECTIONS

### OPK23371

67,5° ISO/SAE CODE 61 FLANGE - SAE J516 / ISO 12151-3

PART. REF.	HOSE BORE			Flange	DIMENSIONS mm						
	DN	Dash	inch		Inch	B	A	D	E	F	
OPK23371-08A08	12	- 8	1/2"	1/2"	9,3	99	30,3	29,5	68		
OPK23371-12A12	19	- 12	3/4"	3/4"	15	118,5	38	38	82		
OPK23371-12A16	19	- 12	3/4"	1"	20	118,5	44,6	38	82		
OPK23371-16A16	25	- 16	1"	1"	19,8	147	44,6	45	98,5		
OPK23371-20A20	31	- 20	1.1/4"	1.1/4"	26	166,5	51	50	114		
OPK23371-24A24	38	- 24	1.1/2"	1.1/2"	32	198,5	60,5	59	136,5		

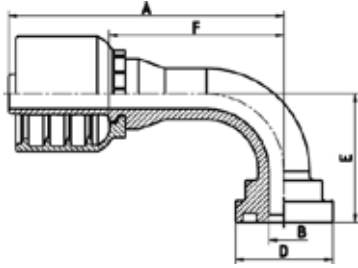

## SAE STANDARD CONNECTIONS

### OPK23391

90° ISO/SAE CODE 61 FLANGE - SAE J516 / ISO 12151-3

PART. REF.	HOSE BORE			Flange	DIMENSIONS mm						
	DN	Dash	inch		Inch	B	A	D	E	F	
OPK23391-08A08	12	- 8	1/2"	1/2"	9,3	85,5	30,3	40	54,5		
OPK23391-08A12	12	- 8	1/2"	3/4"	15	85,5	38	41	54,5		
OPK23391-10A12	16	- 10	5/8"	3/4"	15	90	38	47,5	56		
OPK23391-12A12	19	- 12	3/4"	3/4"	15	101	38	52	64,5		
OPK23391-12A16	19	- 12	3/4"	1"	20	101	44,6	52	64,5		
OPK23391-16A16	25	- 16	1"	1"	19,8	125,5	44,6	62	77,5		
OPK23391-16A20	25	- 16	1"	1.1/4"	26	125,5	51	62	77,5		
OPK23391-20A20	31	- 20	1.1/4"	1.1/4"	26	143	51	70	90,5		
OPK23391-20A24	31	- 20	1.1/4"	1.1/2"	32	143	60,5	72	90,5		
OPK23391-24A24	38	- 24	1.1/2"	1.1/2"	32	170	60,5	84	108		
OPK23391-24A32	38	- 24	1.1/2"	2"	42	170	71,6	84	108		
OPK23391-32A32	51	- 32	2"	2"	42	195	71,6	99	129		

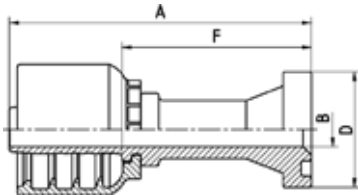

## SAE STANDARD CONNECTIONS

### OPK23611

ISO/SAE CODE 62 FLANGE - SAE J516 / ISO 12151-3

PART. REF.	HOSE BORE			Flange	DIMENSIONS mm						
	DN	Dash	inch		Inch	B	A	D	F		
OPK23611-08A08	12	- 8	1/2"	1/2"	9,3	83	31,8	52			
OPK23611-08A12	12	- 8	1/2"	3/4"	15	99,5	41,5	68,5			
OPK23611-10A08	16	- 10	5/8"	1/2"	9,3	86,5	31,8	52			
OPK23611-10A12	16	- 10	5/8"	3/4"	15	104,5	41,5	70			
OPK23611-12A12	19	- 12	3/4"	3/4"	15	105,5	41,5	69			
OPK23611-12A16	19	- 12	3/4"	1"	20	117,5	47,7	81			
OPK23611-16A16	25	- 16	1"	1"	19,8	130,5	47,7	82,5			
OPK23611-16A20	25	- 16	1"	1.1/4"	26	138	54,2	90			
OPK23611-20A20	31	- 20	1.1/4"	1.1/4"	26	137	54,2	84,5			
OPK23611-20A24	31	- 20	1.1/4"	1.1/2"	32	143	63,7	90,5			
OPK23611-24A24	38	- 24	1.1/2"	1.1/2"	32	154,5	63,6	92,5			
OPK23611-32A32	51	- 32	2"	2"	42	175	79,5	109			

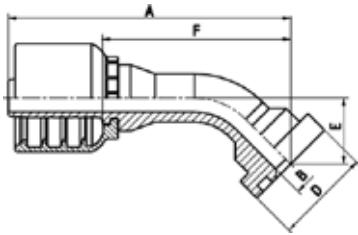

## SAE STANDARD CONNECTIONS

### OPK23641

45° ISO/SAE CODE 62 FLANGE - SAE J516 / ISO 12151-3

PART. REF.	HOSE BORE			Flange	DIMENSIONS mm						
	DN	Dash	inch		Inch	B	A	D	E	F	
OPK23641-08A08	12	- 8	1/2"	1/2"	9,3	93,5	31,8	22	62		
OPK23641-08A12	12	- 8	1/2"	3/4"	15	99	41,5	27,5	68		
OPK23641-10A12	16	- 10	5/8"	3/4"	15	102	41,5	31	67,5		
OPK23641-12A12	19	- 12	3/4"	3/4"	15	109	41,5	28	72,5		
OPK23641-12A16	19	- 12	3/4"	1"	20	114	47,7	32,5	77		
OPK23641-16A12	25	- 16	1"	3/4"	15	128	41,5	30	80		
OPK23641-16A16	25	- 16	1"	1"	19,8	132	47,7	32,5	83,5		
OPK23641-16A20	25	- 16	1"	1.1/4"	26	136,5	54,2	37,5	88,5		
OPK23641-20A20	31	- 20	1.1/4"	1.1/4"	26	147,5	54,2	37,5	95		
OPK23641-20A24	31	- 20	1.1/4"	1.1/2"	32	155	63,7	45	102,5		
OPK23641-24A24	38	- 24	1.1/2"	1.1/2"	32	180	63,7	44	118		
OPK23641-32A32	51	- 32	2"	2"	42	217,5	79,6	60,5	151,5		

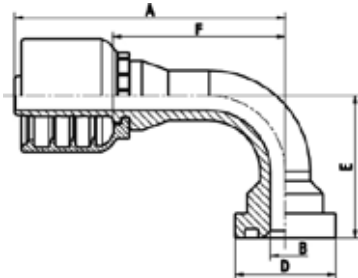

## SAE STANDARD CONNECTIONS

### OPK23691

90° ISO/SAE CODE 62 FLANGE - SAE J516 / ISO 12151-3

PART. REF.	HOSE BORE			Flange	DIMENSIONS mm						
	DN	Dash	inch		Inch	B	A	D	E	F	
OPK23691-08A08	12	- 8	1/2"	1/2"	9,3	85,5	31,8	45	54,5		
OPK23691-08A12	12	- 8	1/2"	3/4"	15	85,5	41,5	53	54,5		
OPK23691-10A12	16	- 10	5/8"	3/4"	15	87,5	41,5	60,5	53,5		
OPK23691-10A16	16	- 10	5/8"	1"	19,8	90	47,7	64	56		
OPK23691-12A12	19	- 12	3/4"	3/4"	15	100,5	41,5	59	64		
OPK23691-12A16	19	- 12	3/4"	1"	20	101	47,7	65	64,5		
OPK23691-16A16	25	- 16	1"	1"	19,8	121,5	47,7	68	73,5		
OPK23691-16A20	25	- 16	1"	1.1/4"	26	121,5	54,2	75	73,5		
OPK23691-20A20	31	- 20	1.1/4"	1.1/4"	26	138	54,2	81	85,5		
OPK23691-20A24	31	- 20	1.1/4"	1.1/2"	32	138	63,7	91,5	85,5		
OPK23691-24A24	38	- 24	1.1/2"	1.1/2"	32	168	63,7	94,5	106		
OPK23691-32A32	51	- 32	2"	2"	42	204	79,6	132	138		

## DIN STANDARD CONNECTIONS

### OPK11110

METRIC MALE 24° CONE SEAT LIGHT DUTY - DIN 20066 / ISO 12151-2

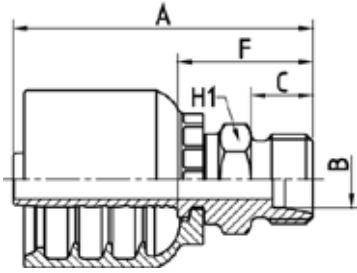

PART. REF.	HOSE BORE			Thread	Pipe	DIMENSIONS mm						
	DN	Dash	inch			T	mm	B	A	C	F	H1
OPK11110-06A16	10	- 6	3/8"	M 16x1,5	10	7	53,5	11	24	17		
OPK11110-06A18	10	- 6	3/8"	M 18x1,5	12	9	54	11	24,5	19		
OPK11110-06A22	10	- 6	3/8"	M 22x1,5	15	10	55	12	25,5	22		
OPK11110-08A22	12	- 8	1/2"	M 22x1,5	15	10	56,5	12	25,5	22		
OPK11110-08A26	12	- 8	1/2"	M 26x1,5	18	12,5	57,5	12	26,5	27		
OPK11110-10A22	16	- 10	5/8"	M 22x1,5	15	10	60	12	25,5	22		
OPK11110-10A26	16	- 10	5/8"	M 26x1,5	18	12,5	61	12	26,5	27		
OPK11110-12A30	19	- 12	3/4"	M 30x2	22	15	66,5	14	30	30		
OPK11110-16A36	25	- 16	1"	M 36x2	28	19,8	80,5	14	32,5	36		
OPK11110-20A45	31	- 20	1.1/4"	M 45x2	35	26	93	16	40,5	46		
OPK11110-24A52	38	- 24	1.1/2"	M 52x2	42	32	105	16	43	55		

## DIN STANDARD CONNECTIONS

### OPK21512/OPK21513

METRIC O-RING FEMALE 24° CONE LIGHT DUTY - DIN 20066 / ISO 12151-2

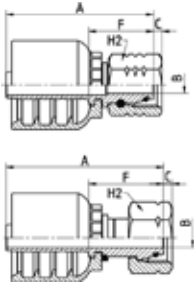

PART. REF.	HOSE BORE			Thread	Pipe	DIMENSIONS mm						
	DN	Dash	inch			T	mm	B	A	C	F	H2
OPK21512-06A16	10	- 6	3/8"	M 16x1,5	10	6	52,5	3	23	19		
OPK21513-06A18	10	- 6	3/8"	M 18x1,5	12	7	52	2	22,5	22		
OPK21513-06A22	10	- 6	3/8"	M 22x1,5	15	9,3	54,5	1,5	25	27		
OPK21512-08A18	12	- 8	1/2"	M 18x1,5	12	7	60	2,9	29	22		
OPK21513-08A22	12	- 8	1/2"	M 22x1,5	15	9,3	56,5	1,5	25,5	27		
OPK21513-08A26	12	- 8	1/2"	M 26x1,5	18	12,5	57	2	26	32		
OPK21513-10A26	16	- 10	5/8"	M 26x1,5	18	12,5	60,5	2	26	32		
OPK21513-10A30	16	- 10	5/8"	M 30x2	22	15	68,5	3	34	36		
OPK21512-12A26	19	- 12	3/4"	M 26x1,5	18	12,5	67,5	2,3	31	32		
OPK21513-12A30	19	- 12	3/4"	M 30x2	22	15	64,5	3	28	36		
OPK21513-12A36	19	- 12	3/4"	M 36x2	28	20	65	3,7	28,5	41		
OPK21513-16A36	25	- 16	1"	M 36x2	28	19,8	77,5	3,7	29,5	41		
OPK21513-20A45	31	- 20	1.1/4"	M 45x2	35	26	85,5	4	33	50		
OPK21513-24A52	38	- 24	1.1/2"	M 52x2	42	32	95	4,5	33	60		

OPK21512: THRUST-WIRE NUT / OPK21513: SLIP-ON NUT



## DIN STANDARD CONNECTIONS

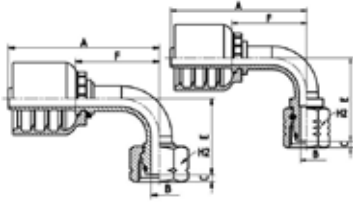

### OPK21592/OPK21593

90° METRIC O-RING FEMALE SWEPT ELBOW 24° CONE LIGHT DUTY  
DIN 20066 / ISO 12151-2

PART. REF.	HOSE BORE			Thread	Pipe	DIMENSIONS mm						
	DN	Dash	inch			T	mm	B	A	C	E	F
OPK21592-06A16	10	- 6	3/8"	M 16x1,5	10	6	65	3	40	35,5	19	
OPK21593-06A18	10	- 6	3/8"	M 18x1,5	12	7	66	2	33,5	36,5	22	
OPK21593-06A22	10	- 6	3/8"	M 22x1,5	15	9,3	66	1,5	35	36,5	27	
OPK21592-08A18	12	- 8	1/2"	M 18x1,5	12	7	75	2,9	48	44	22	
OPK21593-08A22	12	- 8	1/2"	M 22x1,5	15	9,3	76	1,5	39,5	45	27	
OPK21593-08A26	12	- 8	1/2"	M 26x1,5	18	12,5	76	2	40	45	32	
OPK21593-10A26	16	- 10	5/8"	M 26x1,5	18	12,5	86	2	53	51,5	32	
OPK21593-10A30	16	- 10	5/8"	M 30x2	22	15	86	3	54	51,5	36	
OPK21593-12A30	19	- 12	3/4"	M 30x2	22	15	97,5	3	59,5	61,5	36	
OPK21593-16A36	25	- 16	1"	M 36x2	28	19,8	125	3,7	69,5	76,5	41	
OPK21593-20A45	31	- 20	1.1/4"	M 45x2	35	26	146	4	81	93,5	50	
OPK21593-24A52	38	- 24	1.1/2"	M 52x2	42	32	169,5	4,5	98	107,5	60	

OPK21592: THRUST-WIRE NUT / OPK21593: SLIP-ON NUT

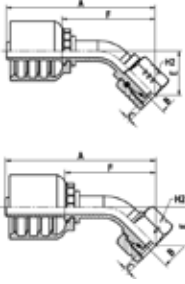

## DIN STANDARD CONNECTIONS

### OPK21542/OPK21543

**45° METRIC O-RING FEMALE SWEPT ELBOW 24° CONE LIGHT DUTY  
DIN 20066 / ISO 12151-2**

PART. REF.	HOSE BORE			Thread	Pipe	DIMENSIONS mm						
	DN	Dash	inch			T	mm	B	A	C	E	F
OPK21542-06A16	10	- 6	3/8"	M 16x1,5	10	6	77	3	21,5	47,5	19	
OPK21543-06A18	10	- 6	3/8"	M 18x1,5	12	7	73	2	16,5	43,5	22	
OPK21543-06A22	10	- 6	3/8"	M 22x1,5	15	9,3	74	1,5	18	45	27	
OPK21543-08A22	12	- 8	1/2"	M 22x1,5	15	9,3	83	1,5	19	52	27	
OPK21543-10A26	16	- 10	5/8"	M 26x1,5	18	12,5	96,5	2	26,5	62	32	
OPK21543-12A30	19	- 12	3/4"	M 30x2	22	15	107,5	3	28,5	71	36	
OPK21543-16A36	25	- 16	1"	M 36x2	28	19,8	133	3,7	32	85	41	
OPK21543-20A45	31	- 20	1.1/4"	M 45x2	35	26	152,5	4	36	100	50	
OPK21543-24A52	38	- 24	1.1/2"	M 52x2	42	32	179	4,5	44,5	117	60	

OPK21542: THRUST-WIRE NUT / OPK21543: SLIP-ON NUT

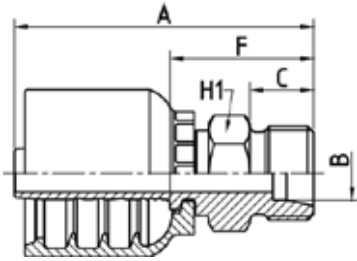

## DIN STANDARD CONNECTIONS

### OPK11210

**METRIC MALE 24° CONE SEAT HEAVY DUTY - DIN 20066 / ISO 12151-2**

PART. REF.	HOSE BORE			Thread	Pipe	DIMENSIONS mm						
	DN	Dash	inch			T	mm	B	A	C	F	H1
OPK11210-06A18	10	- 6	3/8"	M 18x1,5	10	7	56,5	12	27	19		
OPK11210-06A20	10	- 6	3/8"	M 20x1,5	12	7	58,5	12	29	22		
OPK11210-06A22	10	- 6	3/8"	M 22x1,5	14	8	60,5	14	31	22		
OPK11210-08A24	12	- 8	1/2"	M 24x1,5	16	9,3	62,5	14	31,5	24		
OPK11210-10A30	16	- 10	5/8"	M 30x2	20	15	70	16	35,5	30		
OPK11210-12A30	19	- 12	3/4"	M 30x2	20	15	73,5	16	37	30		
OPK11210-12A36	19	- 12	3/4"	M 36x2	25	19,8	77,5	18	41	36		
OPK11210-16A36	25	- 16	1"	M 36x2	25	19,8	90,5	18	42,5	36		
OPK11210-16A42	25	- 16	1"	M 42x2	30	25	92,5	20	44,5	46		
OPK11210-20A52	31	- 20	1.1/4"	M 52x2	38	30	103,5	22	51	55		

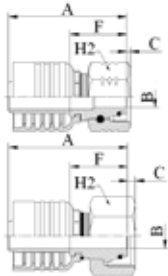

## DIN STANDARD CONNECTIONS

### OPK21612/OPK21613

**METRIC O-RING FEMALE 24° CONE HEAVY DUTY - DIN 20066 / ISO 12151-2**

PART. REF.	HOSE BORE			Thread	Pipe	DIMENSIONS mm						
	DN	Dash	inch			T	mm	B	A	C	F	H2
OPK21613-06A20	10	- 6	3/8"	M 20x1,5	12	7	54,5	2	25,5	24		
OPK21613-06A22	10	- 6	3/8"	M 22x1,5	14	7	62	3	32,5	27		
OPK21613-08A24	12	- 8	1/2"	M 24x1,5	16	9,3	58	4	26,5	30		
OPK21613-10A30	16	- 10	5/8"	M 30x2	20	12,5	65	3,5	30,5	36		
OPK21612-12A30	19	- 12	3/4"	M 30x2	20	12,5	70	2,2	33,5	36		
OPK21613-12A36	19	- 12	3/4"	M 36x2	25	15	70,5	4,5	34	41		
OPK21612-16A36	25	- 16	1"	M 36x2	25	15	83,5	1,7	35,5	41		
OPK21613-16A42	25	- 16	1"	M 42x2	30	19,8	83,5	6,3	35,5	50		
OPK21613-20A52	31	- 20	1.1/4"	M 52x2	38	26	90	8	37,5	60		
OPK21613-24A52	38	- 24	1.1/2"	M 52x2	38	26	111,5	8	49,5	60		

OPK21612: THRUST-WIRE NUT / OPK21613: SLIP-ON NUT

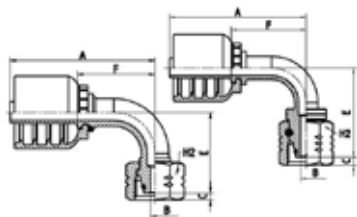

## DIN STANDARD CONNECTIONS

### OPK21692/OPK21693

**90° METRIC O-RING FEMALE SWEPT ELBOW 24° CONE HEAVY DUTY  
DIN 20066 / ISO 12151-2**

PART. REF.	HOSE BORE			Thread	Pipe	DIMENSIONS mm						
	DN	Dash	inch			T	mm	B	A	C	E	F
OPK21693-06A20	10	- 6	3/8"	M 20x1,5	12	7	66	2	35	36,5	24	
OPK21693-06A22	10	- 6	3/8"	M 22x1,5	14	7	66	3	37	36,5	27	
OPK21693-06A24	10	- 6	3/8"	M 24x1,5	16	9,3	66	4	36	36,5	30	
OPK21693-08A24	12	- 8	1/2"	M 24x1,5	16	9,3	76	4	40,5	45	30	
OPK21693-10A30	16	- 10	5/8"	M 30x2	20	12,5	86	3,5	57,5	51,5	36	
OPK21692-12A30	19	- 12	3/4"	M 30x2	20	12,5	98	2,2	67,5	61,5	36	
OPK21693-12A36	19	- 12	3/4"	M 36x2	25	15	97,5	4,5	64,5	61,5	41	
OPK21692-16A36	25	- 16	1"	M 36x2	25	15	127,5	1,7	86	79,5	41	
OPK21693-16A42	25	- 16	1"	M 42x2	30	19,8	127,5	6,3	74,5	79	50	
OPK21693-20A52	31	- 20	1.1/4"	M 52x2	38	26	146	8	85,5	93,5	60	

OPK21692: THRUST-WIRE NUT / OPK21693: SLIP-ON NUT

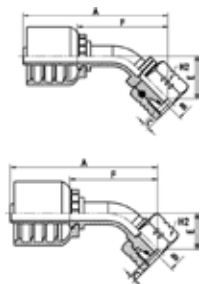

## DIN STANDARD CONNECTIONS

### OPK21642/OPK21643

**45° METRIC O-RING FEMALE SWEPT ELBOW 24° CONE HEAVY DUTY  
DIN 20066 / ISO 12151-2**

PART. REF.	HOSE BORE			Thread	Pipe	DIMENSIONS mm						
	DN	Dash	inch			T	mm	B	A	C	E	F
OPK21643-06A20	10	- 6	3/8"	M 20x1,5	12	7	73,5	2	17	44	24	
OPK21643-06A22	10	- 6	3/8"	M 22x1,5	14	7	75	3	18,5	45,5	27	
OPK21643-08A24	12	- 8	1/2"	M 24x1,5	16	9,3	83,5	4	20	52,5	30	
OPK21643-10A30	16	- 10	5/8"	M 30x2	20	12,5	99,5	3,5	29,5	65,5	36	
OPK21642-12A30	19	- 12	3/4"	M 30x2	20	12,5	113	2,2	34	76,5	36	
OPK21643-12A36	19	- 12	3/4"	M 36x2	25	15	111,5	4,5	32,5	75	41	
OPK21643-16A42	25	- 16	1"	M 42x2	30	19,8	138	6,3	35,5	90	50	
OPK21643-20A52	31	- 20	1.1/4"	M 52x2	38	26	155,5	8	39,5	103	60	

OPK21642: THRUST-WIRE NUT / OPK21643: SLIP-ON NUT

## NF STANDARD CONNECTIONS

### OPK11710

FRENCH METRIC MALE 24° CONE SEAT MILLIMETRIC TYPE

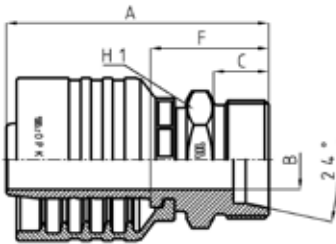

PART. REF.	HOSE BORE			Thread	Pipe	DIMENSIONS mm						
	DN	Dash	inch			T	mm	B	A	C	F	H1
OPK11710-12A30	19	- 12	3/4"	M 30x1,5	22	15	66,5	14	30	30		

## NF STANDARD CONNECTIONS

### OPK11810

FRENCH METRIC MALE 24° CONE SEAT GAZ TYPE

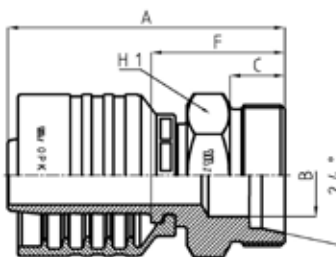

PART. REF.	HOSE BORE			Thread	Pipe	DIMENSIONS mm						
	DN	Dash	inch			T	mm	B	A	C	F	H1
OPK11810-12A36	19	- 12	3/4"	M 36x1,5	26,8	21	70,5	14	34	36		

## NF STANDARD CONNECTIONS

### OPK21813

FRENCH METRIC FEMALE GAZ TYPE

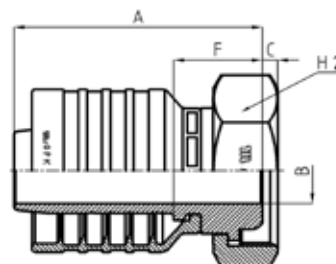

PART. REF.	HOSE BORE			Thread	Pipe	DIMENSIONS mm						
	DN	Dash	inch			T	mm	B	A	C	F	H2
OPK21813-16A45	25	- 16	1"	M 45x1,5	33,5	19,8	75	4,5	27	50		

## JIS STANDARD CONNECTIONS

### OPK24011/OPK24012

JIS METRIC FEMALE (KOMATSU)

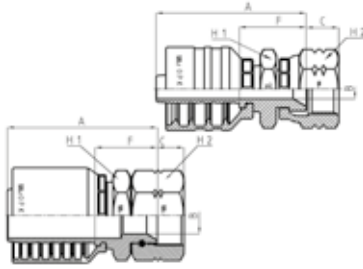

PART. REF.	HOSE BORE			Thread		DIMENSIONS mm						
	DN	Dash	inch			T	B	A	C	F	H1	H2
OPK24011-06A18	10	- 6	3/8"	M 18x1,5		7	53	11,5	23,5	24	24	
OPK24011-08A22	12	- 8	1/2"	M 22x1,5		9,3	56	13	25	27	27	
OPK24011-10A24	16	- 10	5/8"	M 24x1,5		12,5	61	15,1	26,5	32	32	
OPK24011-12A30	19	- 12	3/4"	M 30x1,5		15	68	18,3	31,5	36	36	
OPK24011-16A33	25	- 16	1"	M 33x1,5		19,8	81,5	21,3	33,5	41	41	
OPK24012-24A42	38	- 24	1.1/2"	M 42x1,5		26	106	18,8	44	55	55	

OPK24011: CRIMPED BACK-NUT / OPK24012: THRUST-WIRE NUT

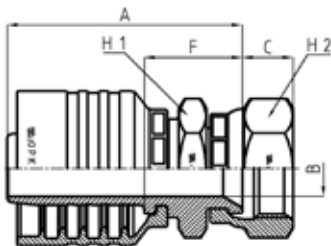

## JIS STANDARD CONNECTIONS

### OPK23811

JIS BSP FEMALE (TOYOTA)

PART. REF.	HOSE BORE			Thread		DIMENSIONS mm						
	DN	Dash	inch			T	B	A	C	F	H1	H2
OPK23811-12A12	19	- 12	3/4"	3/4" - 14		15	62,5	13,5	26	32	32	
OPK23811-16A16	25	- 16	1"	1" - 11		19,8	78,5	14,5	30,5	38	38	

## ORIGINAL EQUIPMENT CONNECTIONS

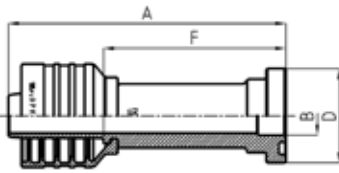

### OPK24111

#### STRAIGHT KOMATSU FLANGE

PART. REF.	HOSE BORE			Flange	DIMENSIONS mm							
	DN	Dash	inch		Inch	B	A	D	F			
OPK24111-10A10	16	- 10	5/8"	5/8"	14	100	34	65,5				

FITTINGS F 10-35

## ORIGINAL EQUIPMENT CONNECTIONS

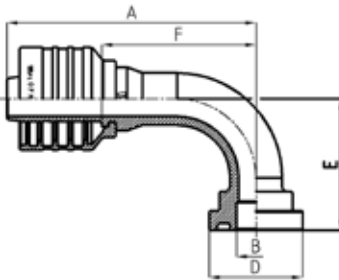

### OPK24191

#### 90° KOMATSU FLANGE

PART. REF.	HOSE BORE			Flange	DIMENSIONS mm							
	DN	Dash	inch		Inch	B	A	D	E	F		
OPK24191-10A10	16	- 10	5/8"	5/8"	14	90	34	47,5	56			

## ORIGINAL EQUIPMENT CONNECTIONS

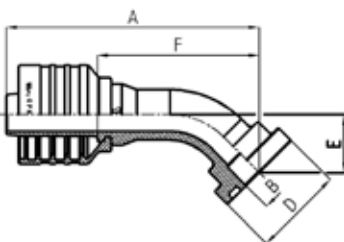

### OPK24141

#### 45° KOMATSU FLANGE

PART. REF.	HOSE BORE			Flange	DIMENSIONS mm							
	DN	Dash	inch		Inch	B	A	D	E	F		
OPK24141-10A10	16	- 10	5/8"	5/8"	14	95	34	22	61			

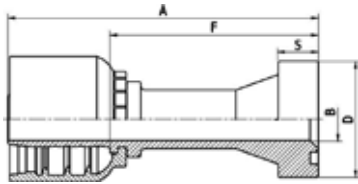

## ORIGINAL EQUIPMENT CONNECTIONS

### OPK23911

#### STRAIGHT SUPERCAT FLANGE

PART. REF.	HOSE BORE			Flange		DIMENSIONS mm						
	DN	Dash	inch			Inch	B	A	D	F	S	
OPK23911-12A12	19	- 12	3/4"	3/4"		15	111	41,5	74,5	14,3		
OPK23911-16A16	25	- 16	1"	1"		19,8	135	47,7	87	14,3		
OPK23911-16A20	25	- 16	1"	1.1/4"		26	140,5	54	92,5	14,3		
OPK23911-20A20	31	- 20	1.1/4"	1.1/4"		26	138,5	54	86	14,3		
OPK23911-24A24	38	- 24	1.1/2"	1.1/2"		32	156	63,6	94	14,3		

FITTINGS  
F 10-36

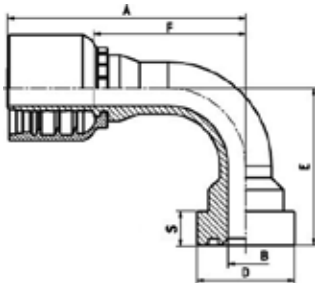

## ORIGINAL EQUIPMENT CONNECTIONS

### OPK23991

#### 90° SUPERCAT FLANGE

PART. REF.	HOSE BORE			Flange		DIMENSIONS mm						
	DN	Dash	inch			Inch	B	A	D	E	F	S
OPK23991-12A12	19	- 12	3/4"	3/4"		15	101	41,5	64,5	64,5	14,3	
OPK23991-16A16	25	- 16	1"	1"		19,8	125,5	47,7	76,5	77,5	14,3	
OPK23991-16A20	25	- 16	1"	1.1/4"		26	123,5	54	80,5	75,5	14,3	
OPK23991-20A20	31	- 20	1.1/4"	1.1/4"		26	138	54	87	85,5	14,3	



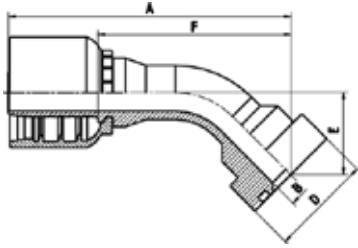

## ORIGINAL EQUIPMENT CONNECTIONS

### OPK23941

#### 45° SUPERCAT FLANGE

PART. REF.	HOSE BORE			Flange		DIMENSIONS mm						
	DN	Dash	inch			Inch	B	A	D	E	F	S
OPK23941-12A12	19	- 12	3/4"	3/4"		15	114	41,5	32	77	14,3	
OPK23941-16A16	25	- 16	1"	1"		19,8	138	47,7	36,5	89,5	14,3	
OPK23941-16A20	25	- 16	1"	1.1/4"		26	140,5	54	40,5	92,5	14,3	
OPK23941-20A20	31	- 20	1.1/4"	1.1/4"		26	151,5	54	41,5	99	14,3	





**EASYFIT**



FITTING CODE	SECTION	PAGE
O82H10	11	4
M12H10	11	1
M12H40	11	1
M12H90	11	2
M22H10	11	2
A52032H	11	3
A52192H	11	4
A52302H	11	3



## MULTIFIT INSERT

### M12H10

#### EF STRAIGHT MALE INSERT

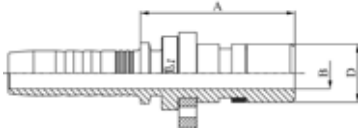

PART. REF.	HOSE BORE			W.P.	DIMENSIONS mm					
	DN	Dash	inch		Bar	B	A	D		
M12H10-04-04	6	-4	1/4"	350	4	30	10			
M12H10-04-06	6	-4	1/4"	350	7	34	13			
M12H10-05-06	8	-5	5/16"	350	7	34	13			
M12H10-06-04	10	-6	3/8"	350	4	30,5	10			
M12H10-06-06	10	-6	3/8"	350	7	34,5	13			
M12H10-06-08	10	-6	3/8"	350	9,3	34,5	16			
M12H10-08-06	12	-8	1/2"	350	7	35	13			
M12H10-08-08	12	-8	1/2"	350	9,3	35	16			
M12H10-10-08	16	-10	5/8"	350	9,3	35	16			
M12H10-10-12	16	-10	5/8"	280	15	44,5	23			
M12H10-12-12	19	-12	3/4"	280	15	44,5	23			

## MULTIFIT INSERT

### M12H40

#### EF 45° ELBOW MALE INSERT

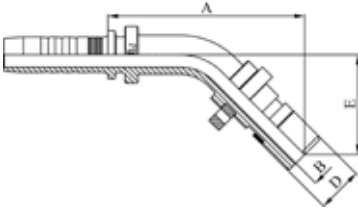

PART. REF.	HOSE BORE			W.P.	DIMENSIONS mm				
	DN	Dash	inch		Bar	B	A	D	E
M12H40-04-04	6	-4	1/4"	350	4	46	10	23,5	
M12H40-04-06	6	-4	1/4"	350	7	52	13	27	
M12H40-05-06	8	-5	5/16"	350	7	53	13	27,5	
M12H40-06-04	10	-6	3/8"	350	4	47	10	23,5	
M12H40-06-06	10	-6	3/8"	350	7	55,5	13	28	
M12H40-08-08	12	-8	1/2"	350	9,3	61,5	16	30	
M12H40-10-08	16	-10	5/8"	350	9,3	65	16	30	
M12H40-10-12	16	-10	5/8"	280	15	79	23	41	
M12H40-12-12	19	-12	3/4"	280	15	85,5	23	42,5	

## MULTIFIT INSERT

### M12H90

#### EF 90° ELBOW MALE INSERT

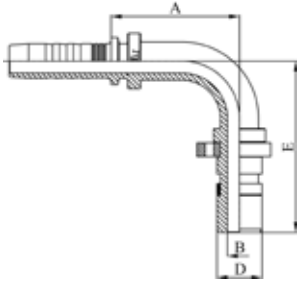

PART. REF.	HOSE BORE			W.P.	DIMENSIONS mm						
	DN	Dash	inch		Bar	B	A	D	E		
M12H90-04-04	6	- 4	1/4"	350	4	30	10	40			
M12H90-04-06	6	- 4	1/4"	350	7	32	13	45			
M12H90-05-06	8	- 5	5/16"	350	7	33,5	13	46,5			
M12H90-06-04	10	- 6	3/8"	350	4	30,5	10	40			
M12H90-06-06	10	- 6	3/8"	350	7	37	13	49,5			
M12H90-08-06	10	- 6	3/8"	350	7	37,5	13	49,5			
M12H90-08-08	12	- 8	1/2"	350	9,3	44	16	55			
M12H90-10-08	16	- 10	5/8"	350	9,3	47	16	55			
M12H90-10-12	16	- 10	5/8"	280	15	55	23	74,5			
M12H90-12-12	19	- 12	3/4"	280	15	62,5	23	79			

## MULTIFIT INSERT

### M22H10

#### EF STRAIGHT FEMALE INSERT

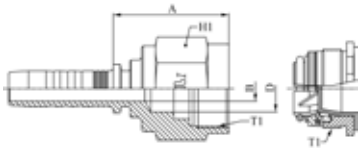

PART. REF.	HOSE BORE			Thread	W.P.	DIMENSIONS mm					
	DN	Dash	inch			T	Bar	B	A	D	H1
M22H10-04-04	6	- 4	1/4"	M 18x1	350	4	30	10	22		
M22H10-06-06	10	- 6	3/8"	M 22x1	350	7	33,5	13	25		
M22H10-08-08	12	- 8	1/2"	M 25x1	350	9,3	34	16	28		
M22H10-10-08	16	- 10	5/8"	M 25x1	350	12,5	34	23	28		
M22H10-10-12	16	- 10	5/8"	M 33x1,5	280	12,5	45,5	23	38		
M22H10-12-12	19	- 12	3/4"	M 33x1,5	280	15	46,5	23	38		



## ADAPTORS

### A52032H

ADAPTOR BSP MALE O-RING BOSS TYPE ISO 1179 EF FEMALE

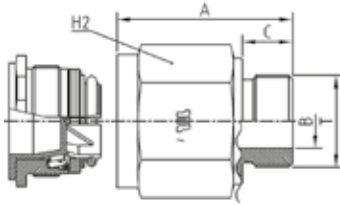

PART. REF.	HOSE BORE			Thread	W.P.	DIMENSIONS mm						
	DN	Dash	inch			T	Bar	B	A	C	D	H1
A52032H-04-04	6	- 4	1/4"	1/4" - 19	350	7,5	34	11,2	10	22		
A52032H-06-04	6	- 4	1/4"	3/8" - 19	350	9	34	11,2	10	22		
A52032H-06-06	10	- 6	3/8"	3/8" - 19	350	9,9	36,5	11,2	13	25		
A52032H-08-06	10	- 6	3/8"	1/2" - 14	350	12,3	39,5	14,5	13	27		
A52032H-08-08	12	- 8	1/2"	1/2" - 14	350	12,3	40	14,5	16	28		
A52032H-12-12	19	- 12	3/4"	3/4" - 14	280	15,5	50,5	14,5	23	38		
A52032H-16-12	19	- 12	3/4"	1" - 11	280	20	53,5	18,6	23	46		

## ADAPTORS

### A52302H

ADAPTOR SAE O-RING BOSS MALE ISO 11926 EF FEMALE

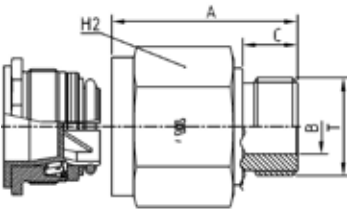

PART. REF.	HOSE BORE			Thread	W.P.	DIMENSIONS mm						
	DN	Dash	inch			T	Bar	B	A	C	D	H1
A52302H-06-04	6	- 4	1/4"	9/16" - 18	350	7	32,5	9,9	10	22		
A52302H-06-06	10	- 6	3/8"	9/16" - 18	350	7	36	9,9	13	25		
A52302H-08-06	10	- 6	3/8"	3/4" - 16	350	9,3	37	11,1	13	25		
A52302H-08-08	12	- 8	1/2"	3/4" - 16	350	9,3	37	11,1	16	28		
A52302H-10-08	12	- 8	1/2"	7/8" - 14	350	12,5	38,5	12,7	16	28		
A52302H-10-12	19	- 12	3/4"	7/8" - 14	280	12,5	49,5	12,7	23	38		
A52302H-12-12	19	- 12	3/4"	1.1/16" - 12	280	15	51	15,1	23	38		

## ADAPTORS

### A52192H

ADAPTOR METRIC MALE ISO 6149 EF FEMALE

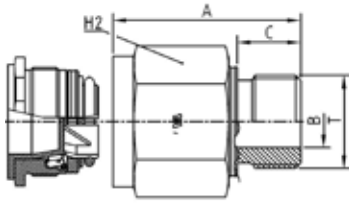

PART. REF.	HOSE BORE			Thread	W.P.	DIMENSIONS mm						
	DN	Dash	inch			T	Bar	B	A	C	D	H1
A52192H-14-04	6	- 4	1/4"	M 14x1,5	350	6	34	11	10	22		
A52192H-16-04	6	- 4	1/4"	M 16x1,5	350	7	35	12,5	10	22		
A52192H-18-06	10	- 6	3/8"	M 18x1,5	350	9	40	14	13	25		
A52192H-22-06	10	- 6	3/8"	M 22x1,5	350	12	40	15	13	27		
A52192H-22-08	12	- 8	1/2"	M 22x1,5	350	12	40	15	16	28		
A52192H-27-08	12	- 8	1/2"	M 27x2	350	15	43	18,5	16	32		
A52192H-27-12	19	- 12	3/4"	M 27x2	280	15	55	18,5	23	38		
A52192H-33-12	19	- 12	3/4"	M 33x2	280	20	54	18,5	23	41		

## ADAPTORS

### O82H10

CARTRIDGE EF

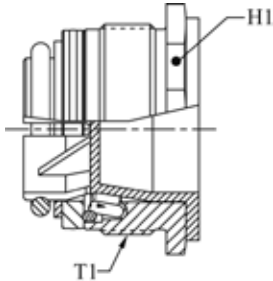

PART. REF.	HOSE BORE			Thread	W.P.	DIMENSIONS mm						
	DN	Dash	inch			T	Bar	D	H1			
O82H10-04	6	- 4	1/4"	M 18x1	350	10	19					
O82H10-06	10	- 6	3/8"	M 22x1	350	13	23					
O82H10-08	12	- 8	1/2"	M 25x1	350	16	26					
O82H10-12	19	- 12	3/4"	M 33x1,5	280	23	34					



**FASTFIT**



FITTING CODE	SECTION	PAGE
A52013H	12	2
A52053H	12	3
A52193H	12	4
A52283H	12	3
A52323H	12	4
M13H10	12	1
M13H40	12	1
M13H90	12	2



## MULTIFIT INSERT

### M13H10

#### FAST-FIT STRAIGHT MALE INSERT

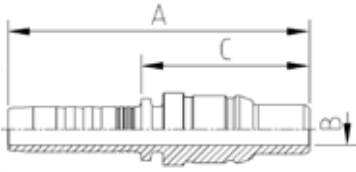

PART. REF.	HOSE BORE			DIMENSIONS mm						
	DN	Dash	inch	B	A	C				
M13H10-04-06	6	-4	1/4"	7	63	35,5				
M13H10-06-06	10	-6	3/8"	7	66,5	37,1				
M13H10-08-08	12	-8	1/2"	9,3	74,5	43,4				
M13H10-12-12	19	-12	3/4"	15	80,5	44				
M13H10-16-16	25	-16	1"	19,8	96	47,8				

## MULTIFIT INSERT

### M13H40

#### FAST-FIT 45° ELBOW MALE INSERT

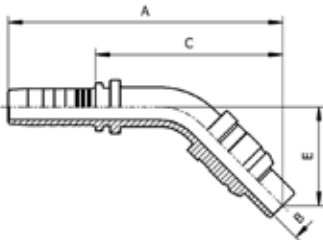

PART. REF.	HOSE BORE			DIMENSIONS mm						
	DN	Dash	inch	B	A	E	F			
M13H40-08-08	12	-8	1/2"	9,3	98	35,5	67			

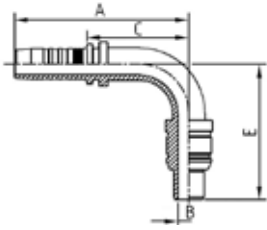

## MULTIFIT INSERT

### M13H90

#### FAST-FIT 90° ELBOW MALE INSERT

FITTINGS  
F 12-2

PART. REF.	HOSE BORE			DIMENSIONS mm							
	DN	Dash	inch	B	A	C	E				
M13H90-04-06	6	- 4	1/4"	7	57,5	30,1	45				
M13H90-06-06	10	- 6	3/8"	7	66,5	37	51				
M13H90-08-08	12	- 8	1/2"	9,3	75	43,8	62,5				
M13H90-12-12	19	- 12	3/4"	15	99	62,5	76,9				
M13H90-16-16	25	- 16	1"	19,8	119	70,6	87				

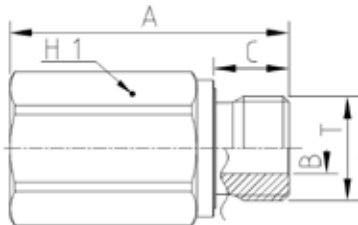

## ADAPTORS

### A52013H

#### BSP MALE OR BOSS TYPE TO ISO 1179- 2

PART. REF.	HOSE BORE			Thread	DIMENSIONS mm						
	DN	Dash	inch	T	B	A	C	H1			
A52013H-04-06	10	- 6	3/8"	1/4" - 19	5	45	12	19			
A52013H-06-06	10	- 6	3/8"	3/8" - 19	8	44,5	12	22			
A52013H-08-08	12	- 8	1/2"	1/2" - 14	10	47	14	27			
A52013H-12-12	19	- 12	3/4"	3/4" - 14	16	53	16	32			
A52013H-16-16	25	- 16	1"	1" - 11	20	60	18	41			



## ADAPTORS

### A52053H

BSP MALE 60° CONE (ISO 8434-6 / BS5200)

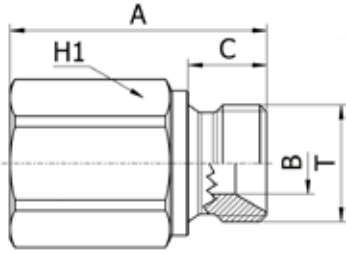

PART. REF.	HOSE BORE			Thread	DIMENSIONS mm							
	DN	Dash	inch		T	B	A	C	H1			
A52053H-08-08	12	- 8	1/2"	1/2" - 14		11	46	14	27			

## ADAPTORS

### A52283H

STRAIGHT ADAPTOR NPTF MALE TO ASME B1.20.3

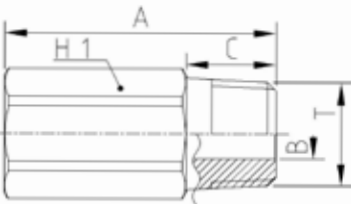

PART. REF.	HOSE BORE			Thread	DIMENSIONS mm							
	DN	Dash	inch		T	B	A	C	H1			
A52283H-04-06	10	- 6	3/8"	1/4" - 18		6	44,5	14,5	19			
A52283H-06-06	10	- 6	3/8"	3/8" - 18		8	43,5	14,5	19			
A52283H-08-08	12	- 8	1/2"	1/2" - 14		9,5	50	19,2	24			
A52283H-12-12	19	- 12	3/4"	3/4" - 14		15	54,5	19,2	32			
A52283H-16-16	25	- 16	1"	1"-11.1/2		19,5	62	24,2	38			

## ADAPTORS

### A52323H

SAE MALE OR BOSS TYPE TO ISO J1926-2

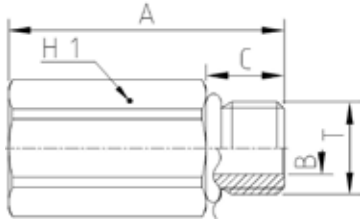

PART. REF.	HOSE BORE			Thread	DIMENSIONS mm						
	DN	Dash	inch		T	B	A	C	H1		
A52323H-04-06	10	- 6	3/8"	7/16" - 20	4,5	42	11	19			
A52323H-06-06	10	- 6	3/8"	9/16" - 18	7,5	42,5	12	19			
A52323H-08-08	12	- 8	1/2"	3/4" - 16	10	46	14	24			
A52323H-12-12	19	- 12	3/4"	1.1/16" - 12	15,5	53,5	18,5	32			
A52323H-16-16	25	- 16	1"	1.5/16" - 12	20,5	56	18,5	38			

## ADAPTORS

### A52193H

STRAIGHT ADAPTOR METRIC MALE ISO 6149-2

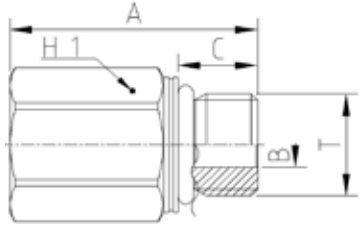

PART. REF.	HOSE BORE			Thread	DIMENSIONS mm						
	DN	Dash	inch		T	B	A	C	H1		
A52193H-14-06	10	- 6	3/8"	M 14x1,5	6	41,5	11	19			
A52193H-18-06	10	- 6	3/8"	M 18x1,5	8	43,5	14	24			
A52193H-22-08	12	- 8	1/2"	M 22x1,5	10	45	15	27			
A52193H-27-12	19	- 12	3/4"	M 27x2	15	53,5	18,5	32			
A52193H-33-16	25	- 16	1"	M 33x2	20	57	18,5	41			



**ROTOFIT**



FITTING CODE	SECTION	PAGE
AR520504	13	7
AR580504	13	7
MR10510	13	1
MR11210	13	4
MR11910	13	4
MR12410	13	2
MR12810	13	2
MR20812	13	1
MR21512	13	4
MR22411	13	3
MR22510	13	2
MR22711	13	2
MR23311	13	3
MR30510	13	5
MR30510FK	13	5
MR32810	13	6
MR40812	13	5
MR42410	13	6
MR42510	13	6
MR43310	13	7



## BS STANDARD CONNECTIONS

### MR10510

BSP MALE PARALLEL 60° CONE SEAT - BS5200 / ISO 8434-6

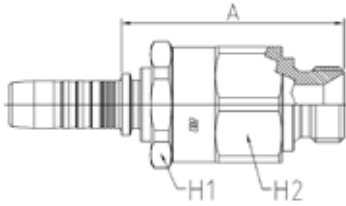

PART. REF.	HOSE BORE			Thread	DIMENSIONS mm						
	DN	Dash	inch		T	A	H1	H2			
MR10510-04-04	6	- 4	1/4"	1/4" - 19	57,5	24	24				
MR10510-06-06	10	- 6	3/8"	3/8" - 19	58	27	27				
MR10510-08-08	12	- 8	1/2"	1/2" - 14	61,5	32	32				
MR10510-10-10	16	- 10	5/8"	5/8" - 14	69,5	36	36				
MR10510-12-12	19	- 12	3/4"	3/4" - 14	71	41	41				
MR10510-12-12FK	19	- 12	3/4"	3/4" - 14	71	41	41				
MR10510-16-16	25	- 16	1"	1" - 11	83	50	50				
MR10510-20-20	31	- 20	1.1/4"	1.1/4" - 11	92	60	60				

## BS STANDARD CONNECTIONS

### MR20812

BSP O-RING FEMALE 60° CONE - BS5200 / ISO 12151-6

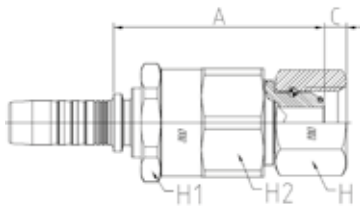

PART. REF.	HOSE BORE			Thread	DIMENSIONS mm						
	DN	Dash	inch		T	A	C	H	H1	H2	
MR20812-04-04	6	- 4	1/4"	1/4" - 19	58	4,1	19	24	24		
MR20812-06-06	10	- 6	3/8"	3/8" - 19	59,5	5,9	22	27	27		
MR20812-08-08	12	- 8	1/2"	1/2" - 14	62,5	6,5	27	32	32		
MR20812-10-10	16	- 10	5/8"	5/8" - 14	68	9,7	28	36	36		
MR20812-12-12	19	- 12	3/4"	3/4" - 14	71	8,5	32	41	41		
MR20812-16-16	25	- 16	1"	1" - 11	81	10,6	38	50	50		

## SAE STANDARD CONNECTIONS

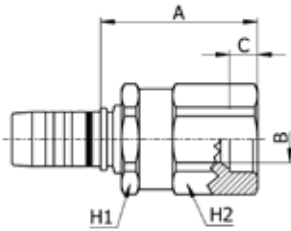

### MR22510

SWIVEL JOINT

JIC FEMALE 37° CONE SEAT - SAE J516 / ISO 12151-5

PART. REF.	HOSE BORE			Thread		DIMENSIONS mm						
	DN	Dash	inch			T	A	H1	H2			
MR22510-20-20	31	- 20	1.1/4"	1.5/8" - 12		93	60	60				

## SAE STANDARD CONNECTIONS

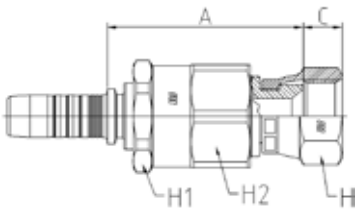

### MR22711

JIC FEM DOUBLE HEXAGON 37° CONE SEAT

PART. REF.	HOSE BORE			Thread		DIMENSIONS mm						
	DN	Dash	inch			T	A	C	H	H1	H2	
MR22711-06-06	10	- 6	3/8"	9/16" - 18		56	9,5	17	27	27		
MR22711-08-08	12	- 8	1/2"	3/4" - 16		60	10,7	22	32	32		
MR22711-08-10	12	- 8	1/2"	7/8" - 14		62	12,5	25	32	32		
MR22711-10-10	16	- 10	5/8"	7/8" - 14		67	12,5	25	36	36		
MR22711-12-12	19	- 12	3/4"	1.1/16" - 12		68,5	14,1	32	41	41		
MR22711-16-16	25	- 16	1"	1.5/16" - 12		80	15,3	38	50	50		

## SAE STANDARD CONNECTIONS

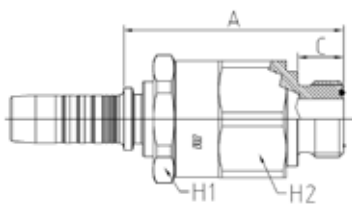

### MR12410

ORFS MALE - SAE J516 / ISO 12151-1

PART. REF.	HOSE BORE			Thread		DIMENSIONS mm						
	DN	Dash	inch			T	A	C	H1	H2		
MR12410-08-08	12	- 8	1/2"	13/16" - 16		60,5	12,8	32	32			
MR12410-10-10	16	- 10	5/8"	1" - 14		69	15,5	36	36			



## SAE STANDARD CONNECTIONS

### MR22411

ORFS FEMALE - SAE J516 / ISO 12151-1 PULLBACK TYPE (CRIMPED BACK-NUT)

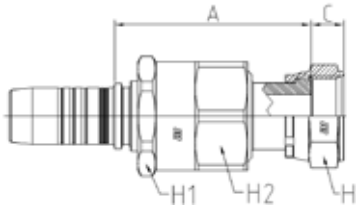

PART. REF.	HOSE BORE			Thread		DIMENSIONS mm						
	DN	Dash	inch			T	A	C	H	H1	H2	
MR22411-06-06	10	- 6	3/8"	11/16" - 16		64,5	9,5	22	27	27		
MR22411-08-08	12	- 8	1/2"	13/16" - 16		70	11	24	32	32		
MR22411-10-10	16	- 10	5/8"	1" - 14		77,5	13,5	30	36	36		
MR22411-12-12	19	- 12	3/4"	1.3/16" - 12		82	14,5	36	41	41		
MR22411-16-16	25	- 16	1"	1.7/16" - 12		90	15	41	50	50		

## SAE STANDARD CONNECTIONS

### MR12810

NPTF MALE 60° CONE SEAT - SAE J516/J514

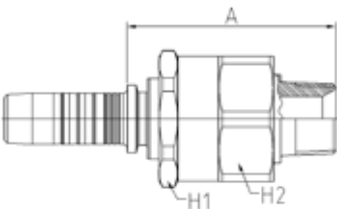

PART. REF.	HOSE BORE			Thread		DIMENSIONS mm						
	DN	Dash	inch			T	A	H1	H2			
MR12810-04-04	6	- 4	1/4"	1/4" - 18		61	24	24				
MR12810-06-06	10	- 6	3/8"	3/8" - 18		60,5	27	27				
MR12810-08-08	12	- 8	1/2"	1/2" - 14		67	32	32				
MR12810-12-12	19	- 12	3/4"	3/4" - 14		74	41	41				
MR12810-16-16	25	- 16	1"	1" - 11,5		88	50	50				

## SAE STANDARD CONNECTIONS

### MR23311

ISO/SAE CODE 61 FLANGE - SAE J516 / ISO 12151-3

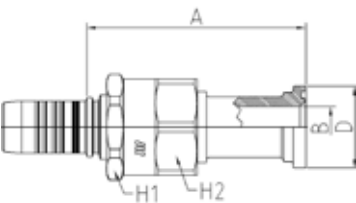

PART. REF.	HOSE BORE			Flange		DIMENSIONS mm						
	DN	Dash	inch			Inch	B	A	D	H1	H2	
MR23311-20-20	31	- 20	1.1/4"	1.1/4"		26	136,5	51	60	60		

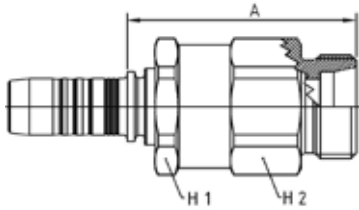

## DIN STANDARD CONNECTIONS

### MR11210

**METRIC MALE 24° CONE SEAT HEAVY DUTY - DIN 20066 / ISO 12151-2**

PART. REF.	HOSE BORE			Thread		DIMENSIONS mm						
	DN	Dash	inch			T	A	H1	H2			
MR11210-10-30	16	- 10	5/8"	M 30x2		66,5	36	36				

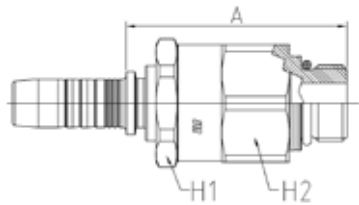

## DIN STANDARD CONNECTIONS

### MR11910

**METRIC MALE HEAVY DUTY SERIES ISO 6149-2**

PART. REF.	HOSE BORE			Thread		DIMENSIONS mm						
	DN	Dash	inch			T	A	H1	H2			
MR11910-06-18	10	- 6	3/8"	M 18x1,5		60,5	27	27				
MR11910-08-22	12	- 8	1/2"	M 22x1,5		62	32	32				

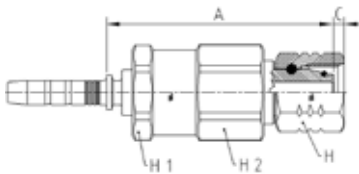

## DIN STANDARD CONNECTIONS

### MR21512

**METRIC O-RING FEMALE 24° CONE LIGHT DUTY - DIN 20066 / ISO 12151-2 (THRUST-WIRE NUT)**

PART. REF.	HOSE BORE			Thread		DIMENSIONS mm						
	DN	Dash	inch			T	A	C	H	H1	H2	
MR21512-04-16	6	- 4	1/4"	M 16x1,5		63	3	19	24	24		

## BS STANDARD CONNECTIONS

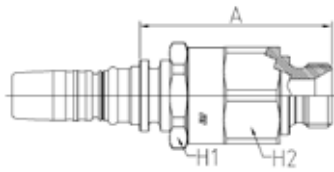

### MR30510

BSP MALE 60° CONE SEAT BS5200

PART. REF.	HOSE BORE			Thread	DIMENSIONS mm						
	DN	Dash	inch		T	A	H1	H2			
MR30510-12-12	19	- 12	3/4"	3/4" - 14	74	46	46				
MR30510-16-16	25	- 16	1"	1" - 11	85,5	55	55				
MR30510-20-20	31	- 20	1.1/4"	1.1/4" - 11	96	65	65				

## BS STANDARD CONNECTIONS

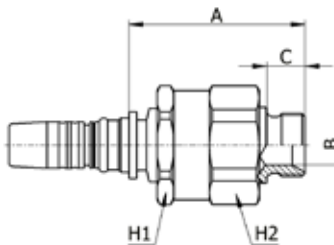

### MR30510FK

BSP MALE 60° CONE SEAT BS5200  
SWIVEL JOINT (VITON)

PART. REF.	HOSE BORE			Thread	DIMENSIONS mm						
	DN	Dash	inch		T	A	H1	H2			
MR30510-12-12FK	19	- 12	3/4"	3/4" - 14	74	46	46				

## BS STANDARD CONNECTIONS

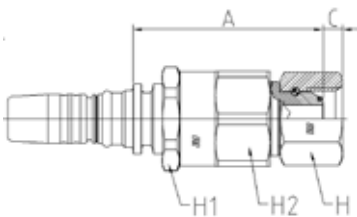

### MR40812

BSP O-RING FEMALE 60° CONE BS5200

PART. REF.	HOSE BORE			Thread	DIMENSIONS mm						
	DN	Dash	inch		T	A	C	H	H1	H2	
MR40812-12-12	19	- 12	3/4"	3/4" - 14	73,5	8,5	32	46	46		
MR40812-16-16	25	- 16	1"	1" - 11	83,5	10,6	41	55	55		

## SAE STANDARD CONNECTIONS

### MR42510

JIC FEM 37° CONE SEAT SAE J514

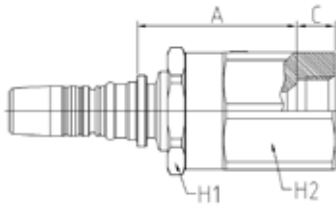

PART. REF.	HOSE BORE			Thread	DIMENSIONS mm							
	DN	Dash	inch		T	A	C	H1	H2			
MR42510-12-12	19	- 12	3/4"	1.1/16" - 12	62,5	15	46	46				
MR42510-16-16	25	- 16	1"	1.5/16" - 12	70	16,5	55	55				

## SAE STANDARD CONNECTIONS

### MR42410

ORFS FEMALE ISO 8434-3 / SAE J1453

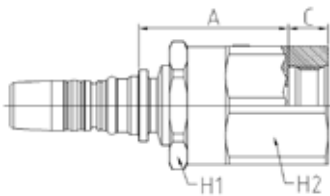

PART. REF.	HOSE BORE			Thread	DIMENSIONS mm							
	DN	Dash	inch		T	A	C	H1	H2			
MR42410-12-12	19	- 12	3/4"	1.3/16" - 12	58	15,5	46	46				
MR42410-16-16	25	- 16	1"	1.7/16" - 12	66	16	55	55				

## SAE STANDARD CONNECTIONS

### MR32810

NPTF MALE 60° CONE SEAT - SAE J516/J514

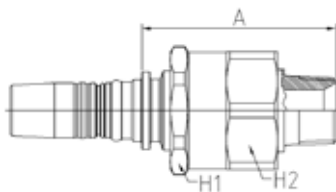

PART. REF.	HOSE BORE			Thread	DIMENSIONS mm						
	DN	Dash	inch		T	A	H1	H2			
MR32810-12-12	19	- 12	3/4"	3/4" - 14	77	46	46				
MR32810-16-16	25	- 16	1"	1" - 11,5	91	55	55				

## SAE STANDARD CONNECTIONS

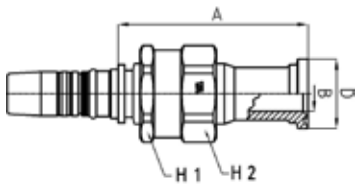

### MR43310

ISO/SAE CODE 61 FLANGE - SAE J516 / ISO 12151-3

PART. REF.	HOSE BORE			Flange	DIMENSIONS mm						
	DN	Dash	inch		Inch	B	A	D	H1	H2	
MR43310-20-20	31	- 20	1.1/4"	1.1/4"	26	145,5	51	65	65		

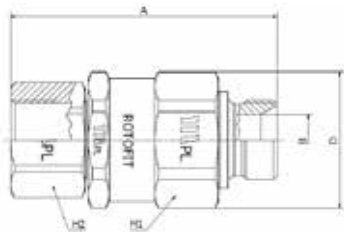

### AR520504

SWIVEL JOINT STRAIGHT  
MALE BSP - FEMALE BSP

PART. REF.	HOSE BORE			Thread	DIMENSIONS mm						
	DN	Dash	inch		T	B	A	D	H1	H2	
AR520504-12-12				3/4" - 14	16,7	87,5	45	41	34		
AR520504-16-16				1" - 11	22,2	102	55	50	50		

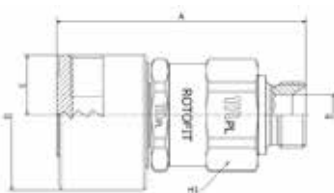

### AR580504

SWIVEL JOINT 90°  
MALE BSP - FEMALE BSP

PART. REF.	HOSE BORE			Thread	DIMENSIONS mm						
	DN	Dash	inch		T	B	A	D	E	H1	
AR580504-12-12				3/4" - 14	16,7	100	60	24	41		





# QUICK COUPLINGS





# Q.SAFE COUPLINGS

## INTRODUCTION

Q.Safe is the Manuli Hydraulics offering for quick coupling applications. Composed of an ever-expanding range of products, the Q.Safe brand has rapidly become an industry byword for quality and performance. The entire Q.Safe product range is manufactured with an Ecoat treatment which provides an environmentally friendly surface coating (chrome free) far exceeding ISO 4520 requirements (salt spray resistance: 240 hours for white corrosion and 400 for red corrosion).

Guaranteeing leak-free performance, the Q.Safe brand is suitable for a wide range of different applications and assures total interchangeability with other quick coupling products on the market. All Q.Safe products are manufactured and assembled in our world-class facility, where they are subjected to stringent quality controls including:

- 100% visual check
- 100% functional test
- 100% air sealing test

Manuli Hydraulics Q.Safe are suggested for the following application fields:

### AGRICULTURE AND FORESTRY (TRACTORS, TRAILERS, HARVESTER MACHINES)

- Quick couplings according to ISO 7241-A standard connectable in whatever pressure conditions:
- MQS-A and MQS-AF, MQS-N in case of no pressure in the hydraulic line.
- MQS-AP, MQS-AFP, MQS-AFM, MQS-AFB, MQS-ARM and MQS-ARB in case of pressure in one or both the hydraulic lines.
- Quick couplings for hydraulic braking systems: MQS-VB according to ISO 5676 standard, MQS-VS
- Flat Face Quick couplings according to ISO 16028 standards: MQS-F, MQS-FP, MQS-FS
- Screw-type couplings: MQS-SG, MQS-SGR
- Quick couplings for diagnosis according to ISO 15171-1 standard: MQS-D
- Quick couplings "direct hose integration": MQS-DHI
- Check valves: MQS-CV, MQS-CVC

### MINING (DRILLS)

- MQS-A, MQS-N,
- MQS-F
- MQS-SG, MQS-SGR
- MQS-SC
- MQS-SH
- MQS-CV, MQS-CVC

### CONSTRUCTION EQUIPMENTS AND UTILITY VEHICLES (EXCAVATORS, SKID STEERS LOADERS, WHEEL-LOADERS, HYDRAULIC TOOLS AND DUMP TRAILERS)

- MQS-A, MQS-AF, MQS-N, MQS-B
- MQS-F, MQS-FP, MQS-FS
- MQS-SG, MQS-SGR
- MQS-D
- Screw type couplings for very high static pressure: MQS-SC
- Screw type couplings for extreme working conditions: MQS-SH
- Wing nut screw type couplings: MQS-ST
- MQS-DHI
- MQS-CV, MQS-CVC

### INDUSTRY

- MQS-F
- MQS-SH
- MQS-B
- MQS-D
- MQS-DHI
- MQS-CV, MQS-CVC

## QUICK COUPLING SELECTION

To ensure that you select the correct quick coupling for your needs, Manuli Hydraulics recommends that the following factors be considered:

**Pressure and Flow Rate** - The selected quick coupling must always be suitable for the pressure and flow rate in the system. Always check that the selected quick coupling's maximum working pressure is equal to or greater than the maximum pressure of the system (including pressure spikes).

**Connection Under Pressure** - Many quick couplings can only be connected / disconnected when the line pressure has been reduced to zero. If this is not possible you should select a quick coupling which is connectible under pressure. When disconnecting couplings the line pressure must be reduced to zero. Avoid using tools to connect / disconnect quick couplings.

**Fluid Compatibility** - Always check that the fluids used are compatible with the materials and seals used in the quick couplings.

**Temperature** - Always verify that the maximum working temperature of the system is within the operational limits of the quick coupling selected.

**Environmental Conditions** - Be aware that certain environmental conditions can cause damage or excessive corrosion to the quick couplings. Some specific examples are environments where there are harsh chemicals, UV radiation or salt waters.

## GENERAL PRECAUTIONS

- Before connecting the quick coupling carefully clean the insert in order to prevent excessive wear on seals.
- Use suitable protective components such as plugs and caps when quick couplings are not in use to prevent unnecessary wear or damage.
- Shock impacts, such as falling on the ground, may damage your quick coupling. Take precautions to avoid this kind of impact.
- Replace damaged / worn O-rings and back-up rings as soon as possible using the recommended spare part kits.
- Inspect each quick coupling after every individual application in order to detect any visible cracks, leakage, damage or corrosion.

# QUICK COUPLINGS INDEX

QUICK COUPLINGS SERIES	FEMALE COUPLING	MALE COUPLING	SHUT-OFF SYSTEM	SPECIFICATIONS	CONNECTION	SIZE										SECTION NUMBER	
						3/8"	1/4"	3/8"	1/2"	5/8"	3/4"	1"	1 1/4"	1 1/2"	2"		
MQS-A ISO A	Q008	Q002	Poppet Valve	ISO 7241 series A	Locking Balls												Q1
		Q004	Shielded Poppet														
	Q009	Q003	Ball Valve														
MQS-AP ISO A connectable under pressure	Q010	Q006	Poppet Valve	ISO 7241 series A	Locking Balls												Q2
MQS-AM ISO A connectable with male under pressure	Q011	-	Poppet Valve	ISO 7241 series A	Locking Balls												Q3
MQS-AB ISO A connectable with both parts under pressure	Q012	-	Poppet Valve	ISO 7241 series A	Locking Balls												Q4
MQS-B ISO B	Q024	Q021	Poppet Valve	ISO 7241 series B	Locking Balls												Q5
MQS-BOP ISO B for drilling BOP unit	Q026 F	Q021 F	Poppet Valve	ISO 7241 series B + flame test res. to API 16D	Locking Balls												Q6
MQS-N Standard	Q032	Q029	Poppet Valve	-	Locking Balls												Q7
	Q033	Q030	Ball Valve														
MQS-NL Free-flow	Q038	Q037	Without	-	Locking Balls												Q8
MQS-NF Standard push-pull	Q036	-	Poppet Valve	-	Locking Balls												Q9
MQS-AF Push-pull	Q013	-	Poppet Valve	ISO 7421 series A	Locking Balls												Q10
MQS-AFP Push-pull connectable under pressure	Q015	-	Poppet Valve	ISO 7421 series A	Locking Balls												Q11
MQS-AFM Push-pull, connectable with male under pressure, flexible mounting	Q016	-	Poppet Valve	ISO 7421 series A	Locking Balls												Q12
MQS-AFB Push-pull connectable with male under pressure, flexible mounting	Q017	-	Poppet Valve	ISO 7421 series A	Locking Balls												Q13
MQS-ARM Push-pull, connectable with male under pressure, rigid mounting	Q018	-	Poppet Valve	ISO 7421 series A	Locking Balls												Q14
MQS-ARB Push-pull connectable with both parts under pressure, rigid mounting	Q019	-	Poppet Valve	ISO 7421 series A	Locking Balls												Q15

# QUICK COUPLINGS INDEX

QUICK COUPLINGS SERIES	FEMALE COUPLING	MALE COUPLING	SHUT-OFF SYSTEM	SPECIFICATIONS	CONNECTION	SIZE										SECTION NUMBER		
						1/8"	1/4"	3/8"	1/2"	5/8"	3/4"	1"	1 1/4"	1 1/2"	2"			
MQS-VB Braking circuit valve	Q048	Q047	Flat Valve	ISO 5676	Locking Balls													Q16
MQS-VS Agricultural valve	Q050	Q049	Flat Valve	-	Screw-on Sleeve													Q17
MQS-D Diagnostic	-	Q045	Flat Valve	ISO 15171-1	Locking Balls													Q18
MQS-F Flat-face	Q041	Q039	Flat Valve	ISO 16028 e HTMA (only 3/8" size)	Locking Balls													Q19
MQS-FH Flat-face high pressure	Q044	Q043	Flat Valve	ISO 16028 e HTMA (only 3/8" size)	Locking Balls													Q20
MQS-FP Flat-face connectable under pressure	-	Q040	Flat Valve	ISO 16028 e HTMA (only 3/8" size)	Locking Balls													Q21
MQS-FS Flat-face screw type	Q067	Q066	Flat Valve	Manuli standards	Screw-on Sleeve													Q22
MQS-SG Screw	Q052	Q051	Poppet Valve	German Market interchangeable ISO 14541 (from 3/8" to 3/4")	Screw-on Sleeve													Q23
MQS-SGR Screw heavy duty	Q062	Q061	Poppet Valve	German Market interchangeable ISO 14541 (from 3/8" to 3/4")	Screw-on Sleeve													Q24
MQS-SH Screw heavy duty	Q054	Q053	Poppet Valve	French Market interchangeable	Screw-on Sleeve													Q25
MQS-SC Screw hydraulic cylinders	Q056	Q055	Poppet Valve & Ball Valve	ISO 14540	Screw-on Sleeve													Q26
MQS-ST Screw for truck	Q058	Q057	Poppet Valve	-	Screw-on Sleeve													Q27
MQS-SS Stainless Steel	Q024	Q021	Poppet Valve	ISO 7241 series B	Locking Balls													Q28
	Q041	Q039	Flat Valve	ISO 16028 e HTMA (only 3/8" size)	Locking Balls													
	Q054	Q053	Poppet Valve	French Market interchangeable	Screw-on Sleeve													

**Q.Safe quick couplings are precision engineered to meet and exceed the main international requirements for this product type. The Q.Safe range of products includes a broad selection of standard items and application focussed solutions.**

## ISO A POPPET VALVES



<b>SIZE</b>	<b>WORKING PRESSURE (Dynamic)</b>	<b>RATED FLOW at 0.2 MPa of pressure drop</b>	<b>CONNECTION EFFORT</b>	<b>OIL SPILLAGE Connection/ Disconnection</b>	<b>MINIMUM BURST PRESSURE</b>	<b>CONNECTION/ DISCONNECTION UNDER PRESSURE</b>

mm	inch	dash	MPa	PSI	l/min	US GPM	N	lb.	cc.	cubic inch	Male		Female		M & F		
											MPa	PSI	MPa	PSI	MPa	PSI	
6.3	¼	04	35	5075	5	1.3	60	13.5	0.7	0.043	200	29000	150	21750	150	21750	Not allowed
10	⅜	06	35	5075	35	9.2	80	18.0	1.4	0.085	140	20300	150	21750	150	21750	Not allowed
12.5	½	08	30	4350	75	19.8	80	18.0	1.8	0.110	125	18125	150	21750	150	21750	Not allowed
20	¾	12	25	3625	147	38.8	90	20.2	7	0.427	100	14500	120	17400	100	14500	Not allowed
25	1	16	25	3625	250	66.1	90	20.2	11	0.671	100	14500	100	14500	100	14500	Not allowed
31.5	1¼	20	25	3625	390	103.0	90	20.2	15	0.915	100	14500	100	14500	105	15225	Not allowed
40	1½	24	22	3190	553	146.1	100	22.5	21	1.281	90	13050	100	14500	100	14500	Not allowed
51	2	32	15	2175	838	221.4	225	50.6	45	2.746	60	8700	60	8700	90	13050	Not allowed

Pressure Drop

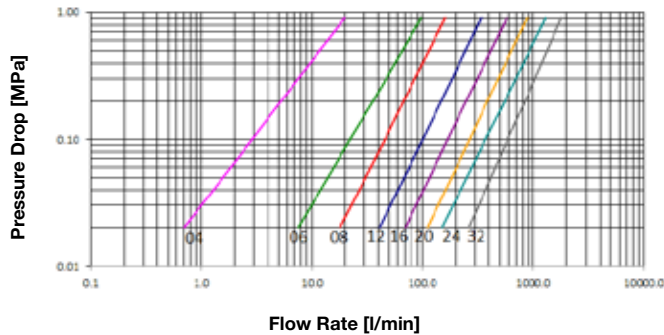

Pressure Drop

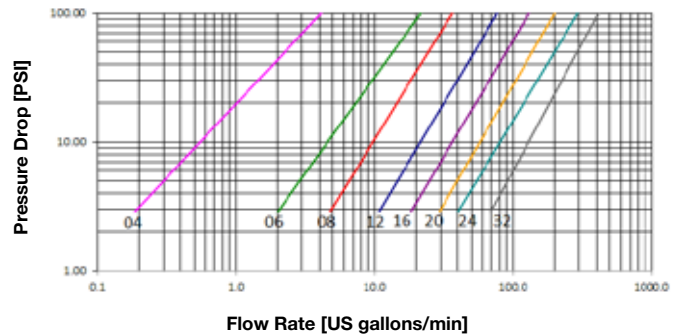

### Product description:

- Reference series on the agriculture and industrial market
- Simple connection and disconnection by pulling back the sleeve
- Positive, quick connection of the male into the female by the latching ball system
- Shut-off by poppet valve
- High resistant materials and hardened male and sleeve to withstand the brinelling effect
- Interchangeability according to ISO 7241-1 series A

<b>Material</b>	Female and male couplings in steel, with some hardened areas, in correspondence to the most stressed points. Springs in C98 steel, seals in NBR (other materials on request) and back-up ring in PTFE
<b>Working Temperature</b>	-22°F up to +230°F (-30°C up to +110°C) For other temperatures, the coupling may be assembled with the specific seals
<b>Safety Factor</b>	4:1 for dynamic pressures
<b>Impulse Pressures</b>	100,000 cycles at 133% of the rated one (freq. 1Hz)
<b>Test Specifications</b>	ISO 7241-2



## ISO A POPPET VALVES - TERMINATION ENDS

BSP

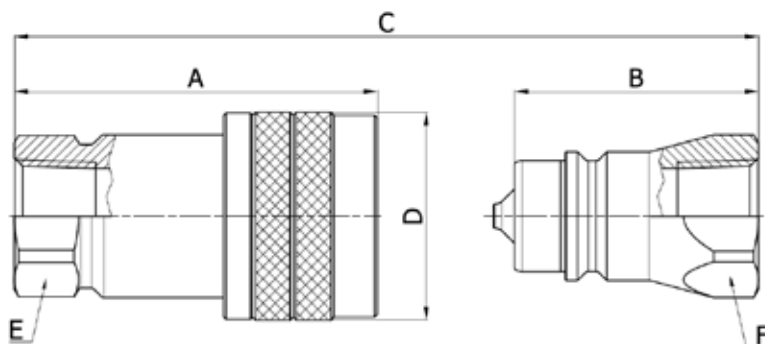

**Q00811021A**

**Q00211021A**

**BSPT TERMINATION ENDS**

**TO ISO 7-1**

**TAPERED**

SIZE			PART NUMBER		THREAD	DIMENSIONS mm					
DN	inch	Size	Female coupling	Male coupling		A	B	C	D	E	F
6.3	1/4"	-04	Q00811021A-04-04	Q00211021A-04-04	1/4"	48.8	34.5	A+B-14,3	ø24	17	17
10	3/8"	-06	Q00811021A-06-06	Q00211021A-06-06	3/8"	57.8	40	A+B-17,8	ø30	22	22
12.5	1/2"	-08	Q00811021A-08-08	Q00211021A-08-08	1/2"	67.1	45	A+B-22,1	ø38	27	27
20	3/4"	-12	Q00811021A-12-12	Q00211021A-12-12	3/4"	83.5	56.5	A+B-27	ø45	34	34

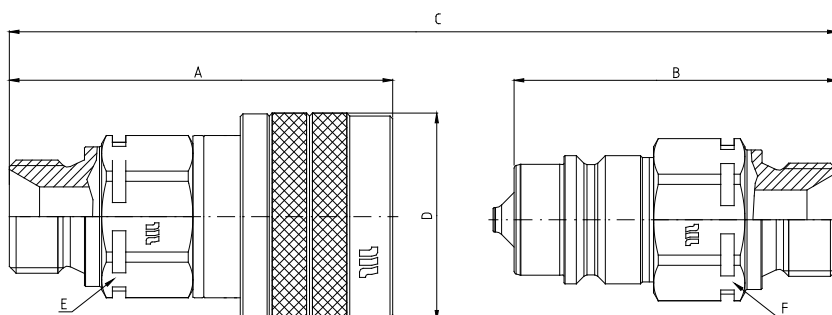

**Q00811050A**

**Q00211050A**

**BSP TERMINATION ENDS**

**TO ISO 8434-6**

SIZE			PART NUMBER		THREAD	DIMENSIONS mm					
DN	inch	Size	Female coupling	Male coupling		A	B	C	D	E	F
10	3/8"	-06	Q00811050A-06-06	Q00211050A-06-06	3/8"	64.7	56.2	A+B-17,5	ø30	22	22
12.5	1/2"	-08	Q00811050A-08-06	Q00211050A-08-06	3/8"	68.9	57.7	A+B-21,8	ø38	27	27
			Q00811050A-08-08	Q00211050A-08-08	1/2"	71.4	60.2	A+B-21,8	ø38	27	27

BSP

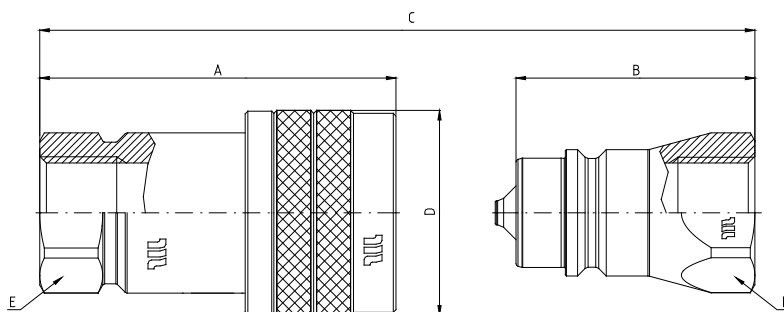

**Q00811041A**

**Q00211041A**

**BSP TERMINATION ENDS**

**TO DIN 3852 X TYPE**

SIZE			PART NUMBER		THREAD	DIMENSIONS mm					
DN	inch	Size	Female coupling	Male coupling		A	B	C	D	E	F
6.3	1/4"	-04	Q00811041A-04-04	Q00211041A-04-04	1/4"	48.8	34.5	A+B-14,2	ø24	17	17
10	3/8"	-06	Q00811041A-06-04	Q00211041A-06-04	1/4"	63	54.5	A+B-17,5	ø30	22	22
			Q00811041A-06-06	Q00211041A-06-06	3/8"	57.8	40	A+B-17,5	ø30	22	22
12.5	1/2"	-08	Q00811041A-08-06	Q00211041A-08-06	3/8"	66.2	55	A+B-21,8	ø38	27	27
			Q00811041A-08-08	Q00211041A-08-08	1/2"	67	45	A+B-21,8	ø38	27	27
20	3/4"	-12	Q00811041A-12-12	Q00211041A-12-12	3/4"	83.5	56.5	A+B-26,7	ø45	34	34
25	1"	-16	Q00811041A-16-12	Q00211041A-16-12	3/4"	97.9	64.5	A+B-32,7	ø52	41	41
			Q00811041A-16-16	Q00211041A-16-16	1"	97.9	64.5	A+B-32,7	ø52	41	41
31.5	1.1/4"	-20	Q00811041A-20-20	Q00211041A-20-20	1.1/4"	118	75	A+B-43	ø69	50	50
40	1.1/2"	-24	Q00811041A-24-24	Q00211041A-24-24	1.1/2"	133	84	A+B-49	ø83	60	60
51	2"	-32	Q00811041A-32-32	Q00211041A-32-32	2"	164	104	A+B-60,2	ø100	75	75

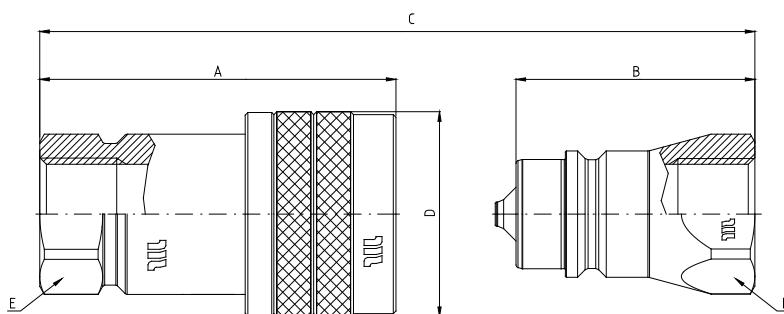

**Q00811041U**

**Q00211041U**

**BSP TERMINATION ENDS**

**TO DIN 3852 X TYPE**

SIZE			PART NUMBER		THREAD	DIMENSIONS mm					
DN	inch	Size	Female coupling	Male coupling		A	B	C	D	E	F
12.5	1/2"	-08	Q00811041U-08-08	Q00211041U-08-08	1/2"	67	45	A+B-21,8	ø38	27	27

**POLYURETHANE SEAL ON FEMALE PART**



## ISO A POPPET VALVES - TERMINATION ENDS

METRIC

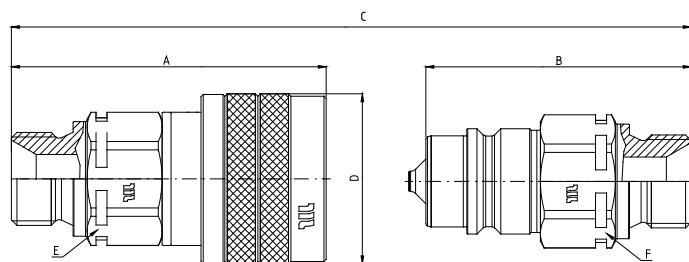

**Q00811110A**

**Q00211110A**

**METRIC TERMINATION ENDS**

**TO ISO 8434-1**

**L SERIES**

SIZE			PART NUMBER		THREAD	DIMENSIONS mm					
DN	inch	Size	Female coupling	Male coupling		A	B	C	D	E	F
6.3	1/4"	-04	Q00811110A-04-14	Q00211110A-04-14	M14x1,5	52.1	42	A+B-14,2	ø24	17	17
10	3/8"	-06	Q00811110A-06-12	Q00211110A-06-12	M12x1,5	61	52.5	A+B-17,5	ø30	22	22
			Q00811110A-06-14	Q00211110A-06-14	M14x1,5	61	52.5	A+B-17,5	ø30	22	22
			Q00811110A-06-16	Q00211110A-06-16	M16x1,5	61	52.5	A+B-17,5	ø30	22	22
			Q00811110A-06-18	Q00211110A-06-18	M18x1,5	61	52.5	A+B-17,5	ø30	22	22
12.5	1/2"	-08	Q00811110A-08-14	Q00211110A-08-14	M14x1,5	65.2	54	A+B-21,8	ø38	27	27
			Q00811110A-08-16	Q00211110A-08-16	M16x1,5	66.2	55	A+B-21,8	ø38	27	27
			Q00811110A-08-18	Q00211110A-08-18	M18x1,5	65.2	54	A+B-21,8	ø38	27	27
			Q00811110A-08-22	Q00211110A-08-22	M22x1,5	66.2	55	A+B-21,8	ø38	27	27
			Q00811110A-08-26	Q00211110A-08-26	M26x1,5	66.2	55	A+B-21,8	ø38	27	27
20	3/4"	-12	Q00811110A-12-22	Q00211110A-12-22	M22x1,5	85.7	66.3	A+B-26,7	ø45	34	34
			Q00811110A-12-26	Q00211110A-12-26	M26x1,5	85.7	66.3	A+B-26,7	ø45	34	34
			Q00811110A-12-30	Q00211110A-12-30	M30x2	87.7	68.3	A+B-26,7	ø45	34	34
25	1"	-16	Q00811110A-16-26	Q00211110A-16-26	M26x1,5	94.5	79.5	A+B-32,7	ø52	41	41
			Q00811110A-16-30	Q00211110A-16-30	M30x2	96.5	81.5	A+B-32,7	ø52	41	41
			Q00811110A-16-36	Q00211110A-16-36	M36x2	97	81.5	A+B-32,7	ø52	41	41

METRIC

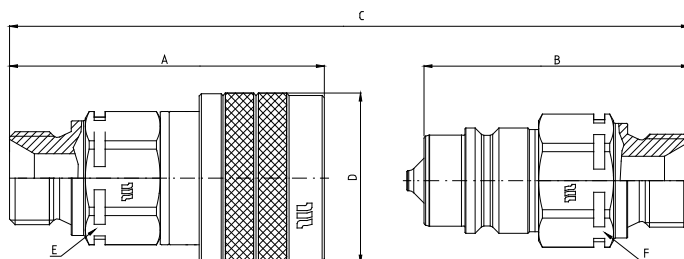

**Q00811120A**

**Q00211120A**

**METRIC TERMINATION ENDS**

**TO ISO 8434-1**

**S SERIES**

SIZE			PART NUMBER		THREAD	DIMENSIONS mm					
DN	inch	Size	Female coupling	Male coupling		A	B	C	D	E	F
10	3/8"	-06	Q00811120A-06-16	Q00211120A-06-16	M16x1,5	62	53.5	A+B-17,5	ø30	22	22
			Q00811120A-06-18	Q00211120A-06-18	M18x1,5	62	53.5	A+B-17,5	ø30	22	22
12.5	1/2"	-08	Q00811120A-08-18	Q00211120A-08-18	M18x1,5	66.2	55	A+B-21,8	ø38	27	27
			Q00811120A-08-20	Q00211120A-08-20	M20x1,5	66.2	55	A+B-21,8	ø38	27	27
			Q00811120A-08-24	Q00211120A-08-24	M24x1,5	68.2	57	A+B-21,8	ø38	27	27
25	1"	-16	Q00811120A-16-30	Q00211120A-16-30	M30x2	98.5	83.5	A+B-32,7	ø52	41	41
			Q00811120A-16-36	Q00211120A-16-36	M36x2	100.5	85.5	A+B-32,7	ø52	41	41
			Q00811120A-16-42	Q00211120A-16-42	M40x2	102.5	87.5	A+B-32,7	ø52	41	41

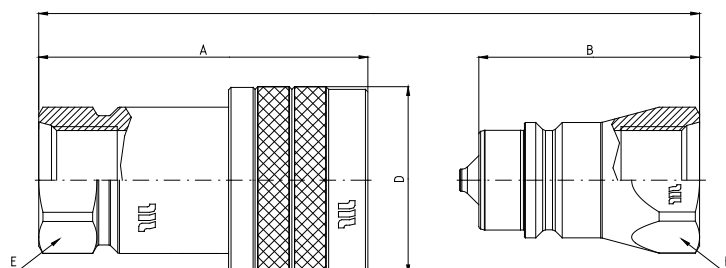

**Q00811191A**

**Q00211191A**

**METRIC TERMINATION ENDS**

**TO ISO 6149-1**

SIZE			PART NUMBER		THREAD	DIMENSIONS mm					
DN	inch	Size	Female coupling	Male coupling		A	B	C	D	E	F
12.5	1/2"	-08	Q00811191A-08-16	Q00211191A-08-16	M16x1,5	66.7	55.5	A+B-21,8	ø38	27	27
			Q00811191A-08-18	Q00211191A-08-18	M18x1,5	68.2	57	A+B-21,8	ø38	27	27
			Q00811191A-08-22	Q00211191A-08-22	M22x1,5	67	48	A+B-21,8	ø38	27	27

## ISO A POPPET VALVES - TERMINATION ENDS

METRIC

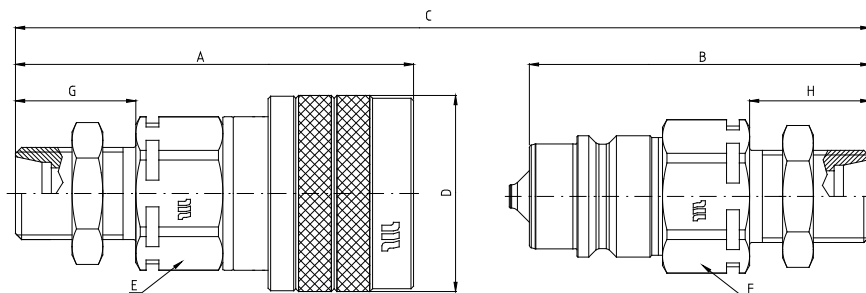

**Q00811770B**

**Q00211770B**

**METRIC TERMINATION ENDS**

**TO ISO 8434-1**

**BULKHEAD L SERIES**

SIZE			PART NUMBER		THREAD	DIMENSIONS mm							
DN	inch	Size	Female coupling	Male coupling		A	B	C	D	E	F	G	H
10	3/8"	-06	Q00811770B-06-12	Q00211770B-06-12	M12x1,5	76	67.5	A+B-17,5	ø30	22	22	25	25
			Q00811770B-06-14	Q00211770B-06-14	M14x1,5	75	66.5	A+B-17,5	ø30	22	22	25	25
			Q00811770B-06-16	Q00211770B-06-16	M16x1,5	75	66.5	A+B-17,5	ø30	22	22	26	26
			Q00811770B-06-18	Q00211770B-06-18	M18x1,5	75	66.5	A+B-17,5	ø30	22	22	26	26
12.5	1/2"	-08	Q00811770B-08-14	Q00211770B-08-14	M14x1,5	80.2	69	A+B-21,8	ø38	27	27	25	25
			Q00811770B-08-16	Q00211770B-08-16	M16x1,5	80.2	69	A+B-21,8	ø38	27	27	26	26
			Q00811770B-08-18	Q00211770B-08-18	M18x1,5	80.2	69	A+B-21,8	ø38	27	27	26	26
			Q00811770B-08-22	Q00211770B-08-22	M22x1,5	81.2	70	A+B-21,8	ø38	27	27	27	27
			Q00811770B-08-26	Q00211770B-08-26	M26x1,5	82.2	71	A+B-21,8	ø38	30	30	28	28
20	3/4"	-12	Q00811770B-12-22	Q00211770B-12-22	M22x1,5	100.7	81.3	A+B-26,7	ø45	27	27	34	34
25	1"	-16	Q00811770B-16-26	Q00211770B-16-26	M26x1,5	110.5	95.5	A+B-32,7	ø52	41	41	29	29
			Q00811770B-16-30	Q00211770B-16-30	M30x2	114.5	95.5	A+B-32,7	ø52	41	41	32	32
			Q00811770B-16-36	Q00211770B-16-36	M36x2	114.5	95.5	A+B-32,7	ø52	41	41	32	32

METRIC

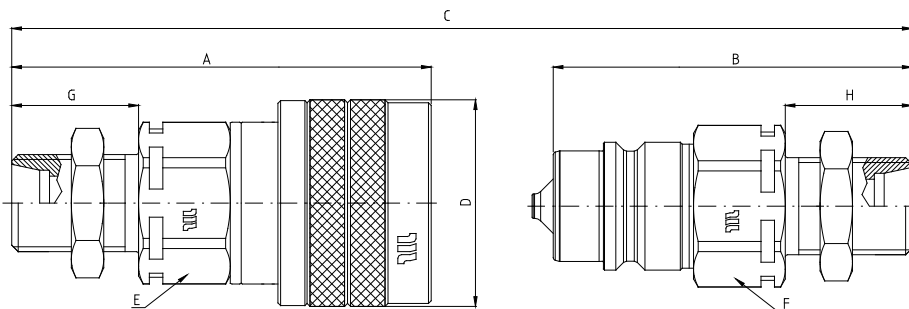

**Q00811870B**

**Q00211870B**

**METRIC TERMINATION ENDS**

**TO ISO 8434-1**

**BULKHEAD S SERIES**

SIZE			PART NUMBER		THREAD	DIMENSIONS mm							
DN	inch	Size	Female coupling	Male coupling		A	B	C	D	E	F	G	H
10	3/8"	-06	Q00811870B-06-16	Q00211870B-06-16	M16x1,5	76	67.5	A+B-17,5	ø30	22	22	27	27
			Q00811870B-06-18	Q00211870B-06-18	M18x1,5	76	67.5	A+B-17,5	ø30	22	22	27	27
12.5	1/2"	-08	Q00811870B-08-18	Q00211870B-08-18	M18x1,5	81.2	70	A+B-21,8	ø38	27	27	27	27
			Q00811870B-08-20	Q00211870B-08-20	M20x1,5	81.2	70	A+B-21,8	ø38	27	27	27	27
			Q00811870B-08-24	Q00211870B-08-24	M24x1,5	83.2	72	A+B-21,8	ø38	27	27	29	29
25	1"	-16	Q00811870B-16-30	Q00211870B-16-30	M30x2	116.5	101.5	A+B-32,7	ø52	41	41	34	34
			Q00811870B-16-36	Q00211870B-16-36	M36x2	118.5	103.5	A+B-32,7	ø52	41	41	36	36
			Q00811870B-16-42	Q00211870B-16-42	M40x2	120.5	105.5	A+B-32,7	ø52	41	41	40	40

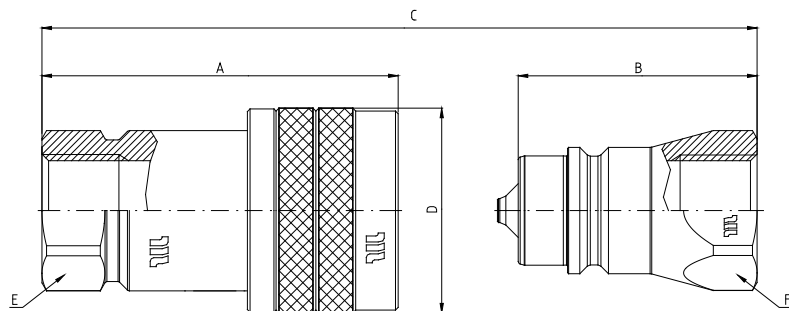

**Q00811141A**

**Q00211141A**

**METRIC TERMINATION ENDS**

**TO ISO 3852-1 X TYPE**

SIZE			PART NUMBER		THREAD	DIMENSIONS mm					
DN	inch	Size	Female coupling	Male coupling		A	B	C	D	E	F
10	3/8"	-06	Q00811141A-06-16	Q00211141A-06-16	M16x1,5	64.5	56	A+B-17,5	ø30	22	22
12.5	1/2"	-08	Q00811141A-08-18	Q00211141A-08-18	M18x1,5	66.2	55	A+B-21,8	ø38	27	27
			Q00811141A-08-20	Q00211141A-08-20	M20x1,5	67	45	A+B-21,8	ø38	27	27
			Q00811141A-08-22	Q00211141A-08-22	M22x1,5	67	48	A+B-21,8	ø38	27	27

## ISO A POPPET VALVES - TERMINATION ENDS

NPT

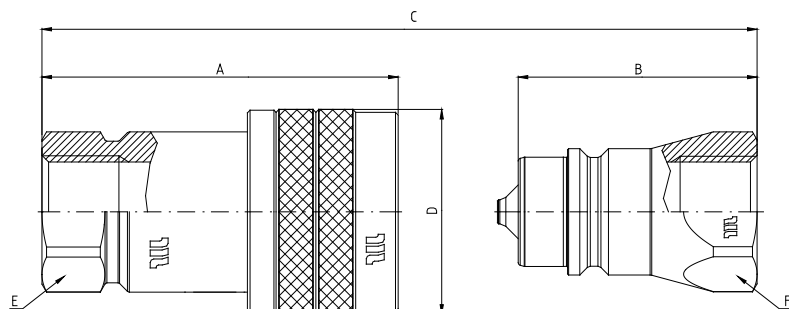

**Q00811341A**

**Q00211341A**

**NPTF TERMINATION ENDS**

**TO ANSI B 1.20.3**

SIZE			PART NUMBER		THREAD	DIMENSIONS mm					
DN	inch	Size	Female coupling	Male coupling		A	B	C	D	E	F
6.3	1/4"	-04	Q00811341A-04-04	Q00211341A-04-04	1/4" NPTF	48.8	34.5	A+B-14,2	ø24	17	17
10	3/8"	-06	Q00811341A-06-06	Q00211341A-06-06	3/8" NPTF	57.8	40	A+B-17,5	ø30	22	22
			Q00811341A-06-08	Q00211341A-06-08	1/2" NPTF	60.8	45	A+B-17,5	ø30	27	27
12.5	1/2"	-08	Q00811341A-08-08	Q00211341A-08-08	1/2" NPTF	67	45	A+B-21,8	ø38	27	27
			Q00811341A-08-12	Q00211341A-08-12	3/4" NPTF	70	53	A+B-22	ø38	34	34
20	3/4"	-12	Q00811341A-12-12	Q00211341A-12-12	3/4" NPTF	83.5	56.5	A+B-26,7	ø45	34	34
25	1"	-16	Q00811341A-16-16	Q00211341A-16-16	1" NPTF	97.9	64.5	A+B-32,7	ø52	41	41
31.5	1.1/4"	-20	Q00811341A-20-20	Q00211341A-20-20	1.1/4" NPTF	118.0	75.0	A+B-43	ø69	50	50
40	1.1/2"	-24	Q00811341A-24-24	Q00211341A-24-24	1.1/2" NPTF	133.0	84.0	A+B-49	ø83	60	60

Q.SAFE

Q 1-7

SAE

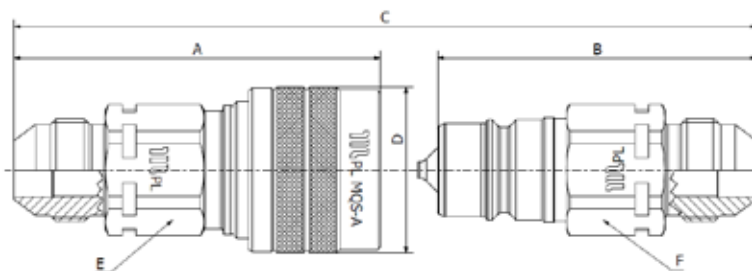

**Q00811250A**

**Q00211250A**

**SAE TERMINATION ENDS**

**TO ISO 8434-2**

SIZE			PART NUMBER		THREAD	DIMENSIONS mm					
DN	inch	Size	Female coupling	Male coupling		A	B	C	D	E	F
10	3/8"	-06	Q00811250A-06-08	Q00211250A-06-08	3/4"-16 UNF	67	58.2	A+B-18,1	ø30	22	22

SAE

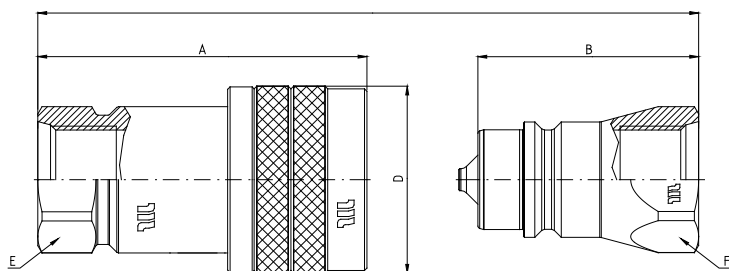

**Q00811301A**

**Q00211301A**

**SAE TERMINATION ENDS**

**TO SAE J1926-1**

SIZE			PART NUMBER		THREAD	DIMENSIONS mm					
DN	inch	Size	Female coupling	Male coupling		A	B	C	D	E	F
6.3	1/4"	-04	Q00811301A-04-06	Q00211301A-04-06	9/16"-18 UNF	50	34.5	A+B-14,2	ø24	17	17
10	3/8"	-06	Q00811301A-06-06	Q00211301A-06-06	9/16"-18 UNF	64.5	56	A+B-17,5	ø30	22	22
12.5	1/2"	-08	Q00811301A-08-08	Q00211301A-08-08	3/4"-16 UNF	67	45	A+B-21,8	ø38	27	27
			Q00811301A-08-10	Q00211301A-08-10	7/8"-14 UNF	69	50	A+B-21,8	ø38	27	27
			Q00811301A-08-12	Q00211301A-08-12	1-1/16"-12 UN	73	54	A+B-21,8	ø38	34	34

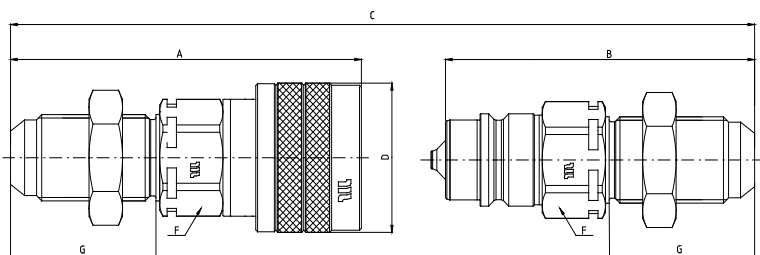

**Q00811230A**

**Q00211230A**

**SAE TERMINATION ENDS**

**TO ISO 8434-2**

**BULKHEAD**

SIZE			PART NUMBER		THREAD	DIMENSIONS mm					
DN	inch	Size	Female coupling	Male coupling		A	B	C	D	F	G
10	3/8"	-06	Q00811230A-06-06	Q00211230A-06-06	9/16"-18 UNF	83.8	75	A+B-18	ø30	22	32.5
			Q00811230A-06-10	Q00211230A-06-10	7/8"-14 UNF	91.3	79.6	A+B-17,5	ø30	27	41
12.5	1/2"	-08	Q00811230A-08-08	Q00211230A-08-08	3/4"-16 UNF	91.8	80.6	A+B-21,8	ø38	27	36.6
			Q00811230A-08-10	Q00211230A-08-10	7/8"-14 UNF	95.3	84.1	A+B-21,8	ø38	27	40.1

## ISO A POPPET VALVES - TERMINATION ENDS

SAE

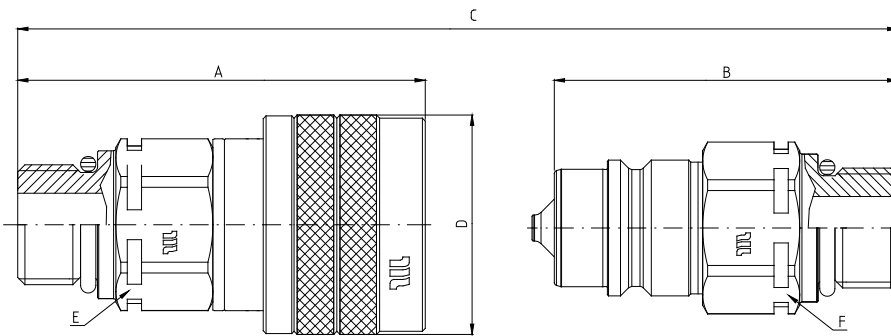

**Q00811320A**

**Q00211320A**

**ORB TERMINATION ENDS**

**TO SAE J1926-2**

**S SERIES**

SIZE			PART NUMBER		THREAD	DIMENSIONS mm					
DN	inch	Size	Female coupling	Male coupling		A	B	C	D	E	F
10	3/8"	-06	Q00811320A-06-06	Q00211320A-06-06	9/16"-18 UNF	63	54.4	A+B-17,5	ø30	22	22
12.5	1/2"	-08	Q00811320A-08-08	Q00211320A-08-08	3/4"-16 UNF	70	60	A+B-21,8	ø38	27	27

Polyurethane seal on female part

ORFS

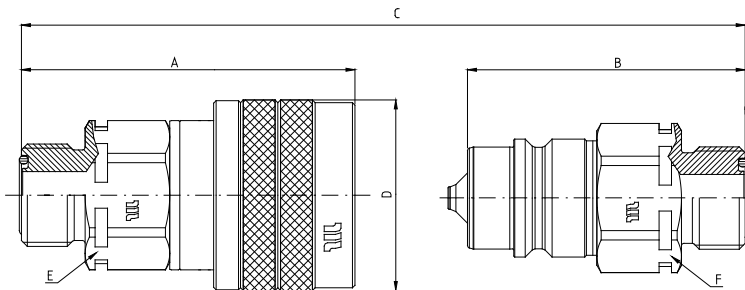

**Q00811240A**

**Q00211240A**

**ORFS TERMINATION ENDS**

**TO ISO 8434-3**

SIZE			PART NUMBER		THREAD	DIMENSIONS mm					
DN	inch	Size	Female coupling	Male coupling		A	B	C	D	E	F
10	3/8"	-06	Q00811240A-06-04	Q00211240A-06-04	9/16"-18 UN	60.8	52.3	A+B-17,5	ø30	22	22
			Q00811240A-06-06	Q00211240A-06-06	11/16"-16 UN	61.2	52.7	A+B-17,5	ø30	22	22
12.5	1/2"	-08	Q00811240A-08-08	Q00211240A-08-08	13/16"-16 UN	66.2	55.8	A+B-21,8	ø38	27	27
25	1"	-16	Q00811240A-16-16	Q00211240A-16-16	1.7/16"-12 UN	100	81.8	A+B-32,7	ø52	41	41

## ISO A SHIELDED POPPET VALVES - TERMINATION ENDS

BSP

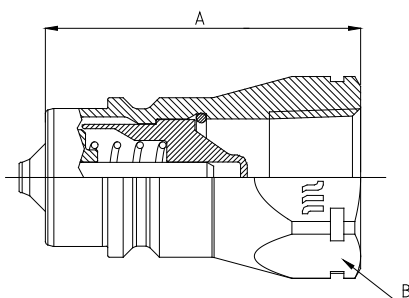

### Q00411041A

BSP TERMINATION ENDS  
TO DIN 3852 X TYPE

SIZE			PART NUMBER	THREAD	DIMENSIONS mm				
DN	inch	Size	Male coupling		A	B			
12.5	1/2"	08	Q00411041A-08-08	1/2"	47	27			

NPT

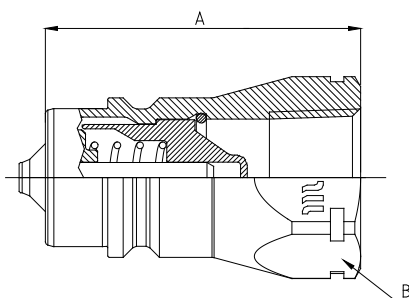

### Q00411341A

NPTF TERMINATION ENDS  
TO ANSI B 1.20.3

SIZE			PART NUMBER	THREAD	DIMENSIONS mm				
DN	inch	Size	Male coupling		A	B			
12.5	1/2"	08	Q00411341A-08-08	1/2" NPTF	47	27			

SAE

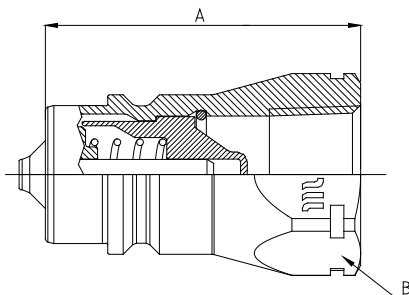

### Q00411301A

SAE TERMINATION ENDS  
TO SAE J1926-1

SIZE			PART NUMBER	THREAD	DIMENSIONS mm				
DN	inch	Size	Male coupling		A	B			
12.5	1/2"	08	Q00411301A-08-08	3/4" UNF	47	27			





<b>SIZE</b>	<b>WORKING PRESSURE (Dynamic)</b>	<b>RATED FLOW at 0.2 MPa of pressure drop</b>	<b>CONNECTION EFFORT</b>	<b>OIL SPILLAGE Connection/ Disconnection</b>	<b>MINIMUM BURST PRESSURE</b>	<b>CONNECTION/ DISCONNECTION UNDER PRESSURE</b>

mm	inch	dash	MPa	PSI	l/min	US GPM	N	lb.	cc.	cubic inch	Male		Female		M & F		
											MPa	PSI	MPa	PSI	MPa	PSI	
12.5	½	08	21	3045	47	12.4	65	144	1.6	0.098	85	12325	100	14500	150	21750	Not allowed

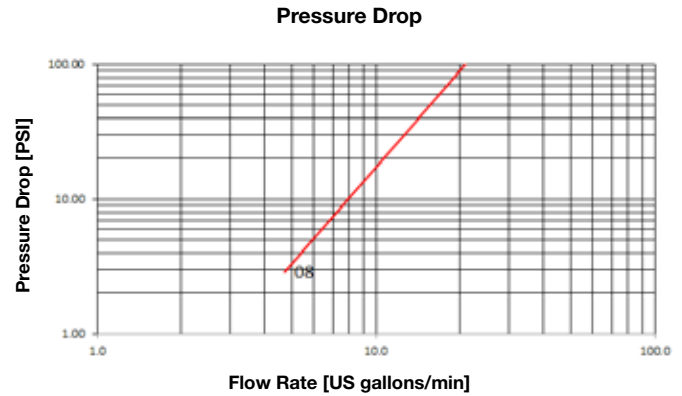
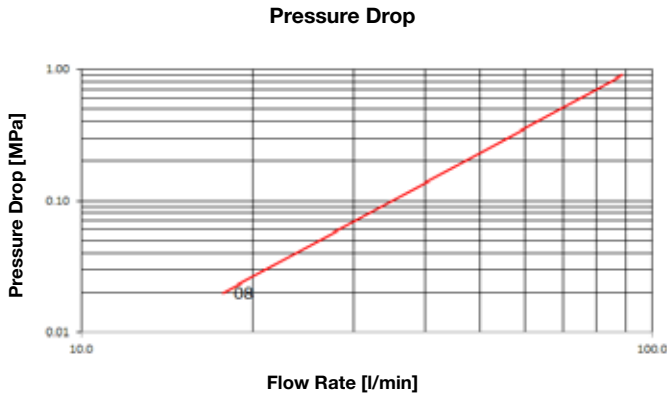

### Product description:

- Simple connection and disconnection by pulling back the sleeve
- Positive, quick connection of the male into the female by the latching ball system
- Shut-off by ball valve
- High resistant materials and hardened male and sleeve to withstand the brinelling effect
- Interchangeability according to ISO 7241-1 series A

<b>Material</b>	Female couplings in steel, with some hardened areas, in correspondence to the most stressed points. Male couplings in high grade carbon steel. Springs in C98 steel, seals in NBR (other materials on request) and back-up ring in PTFE
<b>Working Temperature</b>	-22°F up to +230°F (-30°C up to +110°C) For other temperatures, the coupling may be assembled with the specific seals
<b>Safety Factor</b>	4:1 for dynamic pressures
<b>Impulse Pressures</b>	100,000 cycles at 133% of the rated one (freq. 1Hz)
<b>Test Specifications</b>	ISO 7241-2



## ISO A BALL VALVES - TERMINATION ENDS

BSP

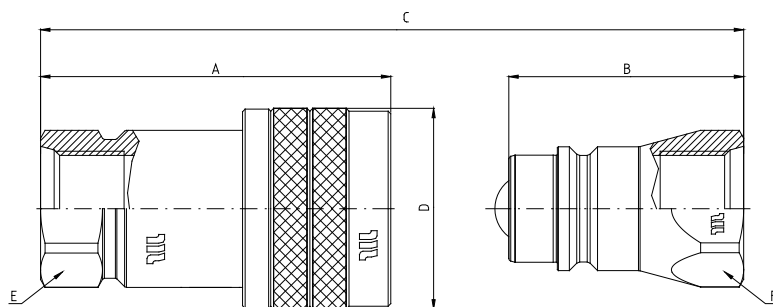

**Q00911041A**

**Q00311041A**

**BSP TERMINATION ENDS**

**TO DIN 3852**

SIZE			PART NUMBER		THREAD	DIMENSIONS mm					
DN	inch	Size	Female coupling	Male coupling		A	B	C	D	E	F
12.5	1/2"	-08	Q00911041A-08-08	Q00310041A-08-08	1/2"	68.2	46.2	A+B-21,8	ø38	27	27

NPT

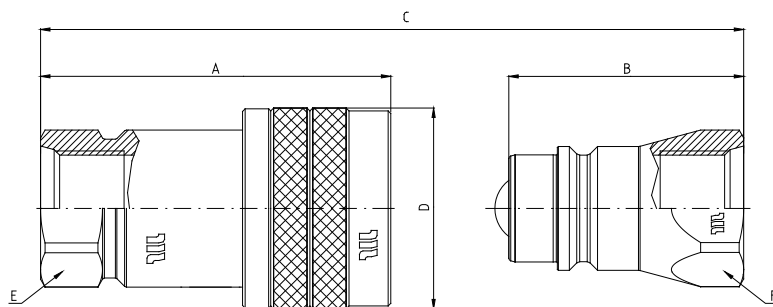

**Q00911341A**

**Q00310341A**

**NFTS TERMINATION ENDS**

**TO ANSI B 1.20.3**

SIZE			PART NUMBER		THREAD	DIMENSIONS mm					
DN	inch	Size	Female coupling	Male coupling		A	B	C	D	E	F
12.5	1/2"	-08	Q00911341A-08-08	Q00310341A-08-08	1/2" NPTF	68.2	46.2	A+B-21,8	ø38	27	27

NPT

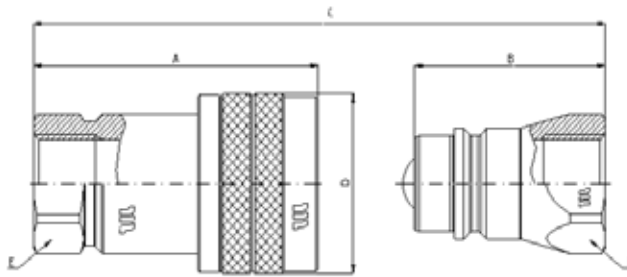

**Q00911341A**

**Q00310341A**

**NFTS TERMINATION ENDS**

**TO ANSI B 1.20.3**

SIZE			PART NUMBER		THREAD	DIMENSIONS mm					
DN	inch	Size	Female coupling	Male coupling		A	B	C	D	E	F
12.5	1/2"	-08	Q00911341A-08-08	Q00310341A-08-08	1/2" NPTF	68.2	46.2	A+B-21,8	ø38	27	27

SAE

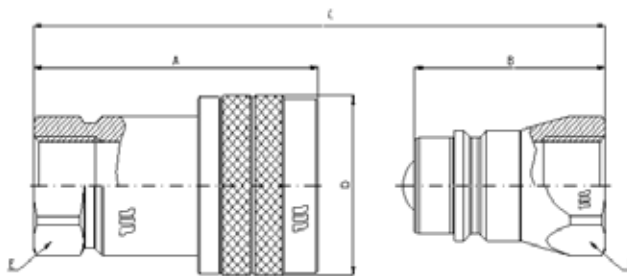

**Q00911301A**

**Q00310301A**

**SAE TERMINATION ENDS**

**TO SAE J1926-1**

SIZE			PART NUMBER		THREAD	DIMENSIONS mm					
DN	inch	Size	Female coupling	Male coupling		A	B	C	D	E	F
12.5	1/2"	-08	Q00911301A-08-08	Q00310301A-08-08	3/4"-16 UNF	67	45	A+B-21,8	ø38	27	27

## ISO A CONNECTABLE UNDER PRESSURE



<b>SIZE</b>	<b>WORKING PRESSURE (Dynamic)</b>	<b>RATED FLOW at 0.2 MPa of pressure drop</b>	<b>CONNECTION EFFORT</b>	<b>OIL SPILLAGE Connection/ Disconnection</b>	<b>MINIMUM BURST PRESSURE</b>		<b>CONNECTION/ DISCONNECTION UNDER PRESSURE</b>

mm	inch	dash	MPa	PSI	L/min	US GPM	N	lb.	cc.	cubic inch	Male		Female		M & F		
											MPa	PSI	MPa	PSI	MPa	PSI	
12.5	½	08	30	4350	68	18.0	80	178	2	0.122	120	17400	120	17400	160	23200	Only connection
										With 0 MPa pressure							

Pressure Drop

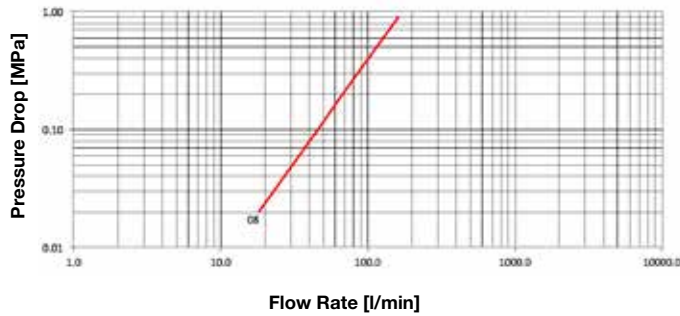

Pressure Drop

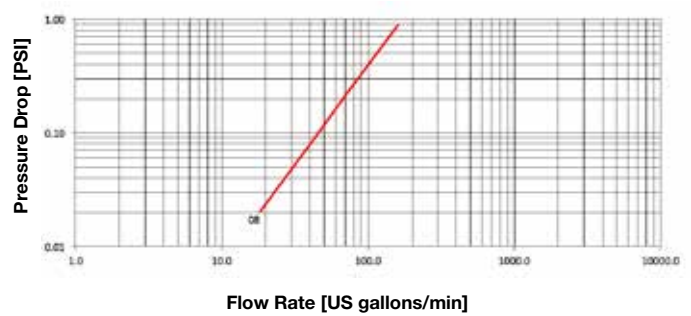

### Product description:

- Connectable under pressure thanks to a frontal micro-valve
- Connection and disconnection is possible by pulling back the sleeve
- Positive, quick connection of the male into the female by the latching ball system
- Shut-off by poppet valve
- High resistant materials
- Connectability at the maximum working pressure
- Interchangeable according to ISO 7241 series A

<b>Material</b>	Female couplings in steel, with some hardened areas, in correspondence to the most stressed points. Male couplings in high grade carbon steel. Springs in C98 steel, seals in NBR and polyurethane (other materials on request) and back-up ring in PTFE
<b>Working Temperature</b>	-22°F up to +230°F (-30°C up to +110°C) For other temperatures, the quick coupling is assembled with specific seals
<b>Safety Factor</b>	4:1 for dynamic pressures
<b>Impulse Pressures</b>	Withstands 100,000 cycles of impulse pressure at 133% of the rated one (freq. 1Hz)
<b>Test Specifications</b>	ISO 7241-2



## ISO A CONNECTABLE UNDER PRESSURE - TERMINATION ENDS

### BSP

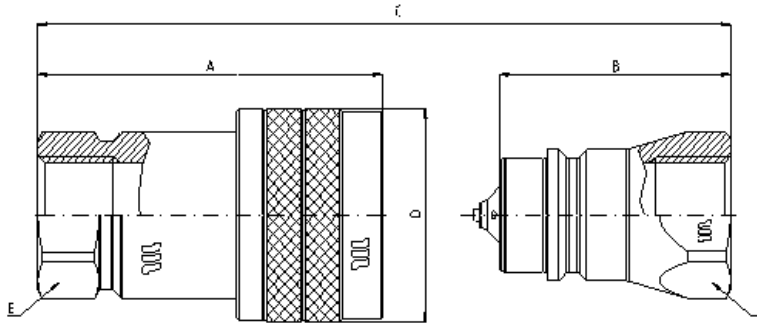

**Q01011041A**

**Q00611041A**

**BSP TERMINATION ENDS  
TO DIN 3852 X TYPE**

SIZE			PART NUMBER		THREAD	DIMENSIONS mm					
DN	inch	Size	Female coupling	Male coupling		A	B	C	D	E	F
12.5	1/2"	-08	Q01011110A-08-18	Q00611110A-08-18	M18x1,5	65.2	54	A+B-21,8	ø38	27	27

### METRIC

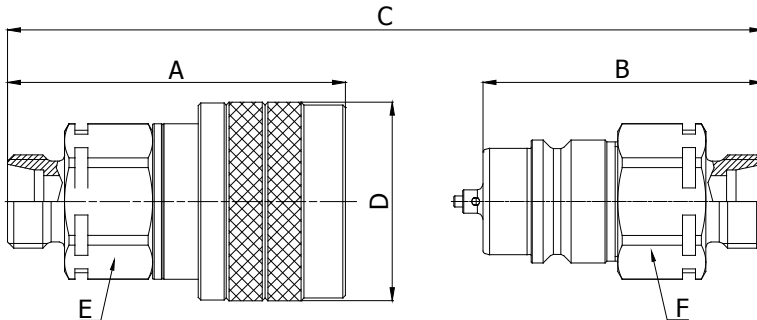

**Q01011110A**

**Q00611110A**

**METRIC TERMINATION END  
TO ISO 8434-1  
L SERIES**

SIZE			PART NUMBER		THREAD	DIMENSIONS mm					
DN	inch	Size	Female coupling	Male coupling		A	B	C	D	E	F
12.5	1/2"	-08	Q01011110A-08-18	Q00611110A-08-18	M18x1,5	65.2	54	A+B-21,8	ø38	27	27

### NPT

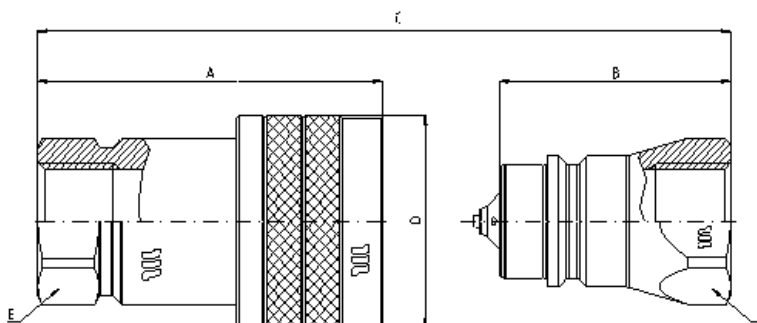

**Q01011341A**

**Q00611341A**

**NPTF TERMINATION END  
TO ANSI B 1.20.3**

SIZE			PART NUMBER		THREAD	DIMENSIONS mm					
DN	inch	Size	Female coupling	Male coupling		A	B	C	D	E	F
12.5	1/2"	-08	Q01011110A-08-18	Q00611110A-08-18	M18x1,5	65.2	54	A+B-21,8	ø38	27	27







## ISO A FEMALE CONNECTABLE UNDER PRESSURE

<b>SIZE</b>	<b>WORKING PRESSURE (Dynamic)</b>	<b>RATED FLOW at 0.2 MPa of pressure drop</b>	<b>CONNECTION EFFORT</b>	<b>OIL SPILLAGE Connection/ Disconnection</b>	<b>MINIMUM BURST PRESSURE</b>	<b>CONNECTION/ DISCONNECTION UNDER PRESSURE</b>

mm	inch	dash	MPa	PSI	l/min	US GPM	N	lb.	cc.	cubic inch	Female		M & F		Connection only, with male under pressure
											MPa	PSI	MPa	PSI	
12.5	½	08	30	4350	71	18.8	80	178	2	0.122	125	18125	125	18125	

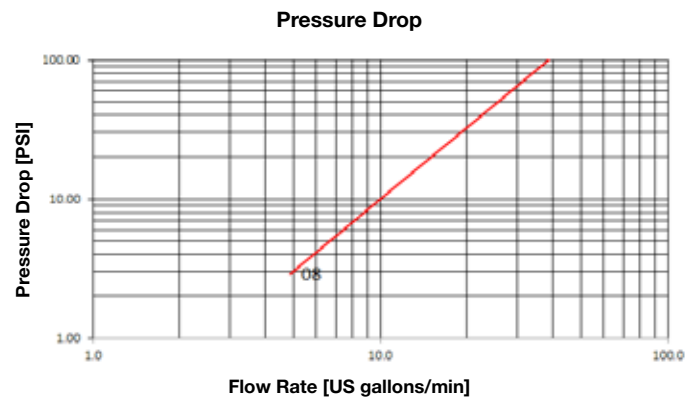
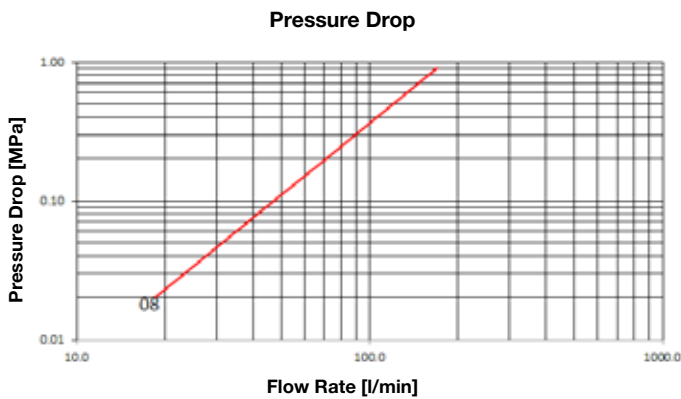

### Product description:

- Connectable with male ISO A under pressure
- High working pressure 30MPa
- Simple connection and disconnection by pulling back the sleeve
- No shut-off, Manuli mechanical valve block system
- Installations on hoses, pipe and direct to port
- Wide range of termination ends
- Interchangeability according to ISO 7241-1 part A

<b>Material</b>	Female couplings in steel, with some hardened areas, in correspondence to the most stressed points. Carbonitrided valve, and sleeve, springs in C98 steel, seals in NBR (other materials on request) and back-up ring in PTFE
<b>Working Temperature</b>	-22°F up to +230°F (-30°C up to +110°C) For other temperatures, the quick coupling is assembled with specific seals
<b>Safety Factor</b>	4:1 for dynamic pressures
<b>Impulse Pressures</b>	500,000 cycles (connected and disconnected conditions) at 120% of the rated one (freq. 1Hz)
<b>Test Specifications</b>	ISO 7241-2



## ISO A MALE CONNECTABLE UNDER PRESSURE - TERMINATION ENDS

BSP

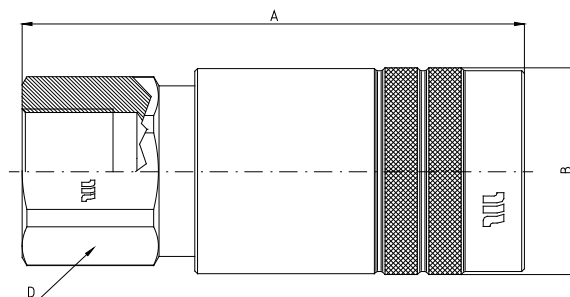

### Q01111041A

BSP TERMINATION ENDS

TO DIN 3852 X TYPE

SIZE			PART NUMBER	THREAD	DIMENSIONS mm					
DN	inch	Size	Female coupling		A	B	D			
12.5	1/2"	-08	Q01111041A-08-08	1/2"	91.7	ø38,3	32			

METRIC

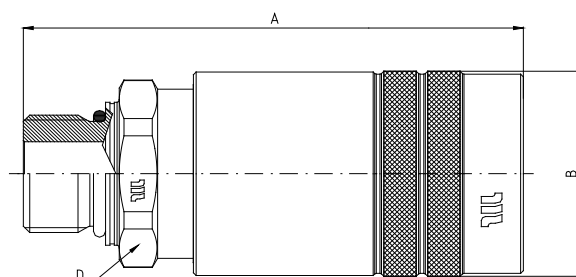

### Q01111190A

METRIC TERMINATION ENDS

TO ISO 6149-1

SIZE			PART NUMBER	THREAD	DIMENSIONS mm					
DN	inch	Size	Female coupling		A	B	D			
12.5	1/2"	-08	Q01111190A-08-22	M22x1,5	91.2	ø38,3	32			





## ISO A FEMALE CONNECTABLE UNDER PRESSURE

	<b>MPa</b>		<b>N</b>				
<b>SIZE</b>	<b>WORKING PRESSURE (Dynamic)</b>	<b>RATED FLOW at 0.2 MPa of pressure drop</b>	<b>CONNECTION EFFORT</b>	<b>OIL SPILLAGE Connection/ Disconnection</b>	<b>MINIMUM BURST PRESSURE</b>		<b>CONNECTION/ DISCONNECTION UNDER PRESSURE</b>

mm	inch	dash	MPa	PSI	l/min	US GPM	N	lb.	cc.	cubic inch	Female		M & F		Connection only, with male and female under pressure
											MPa	PSI	MPa	PSI	
12.5	½	08	30	4350	71	18.8	80	178	2	0.122	125	18125	125	18125	

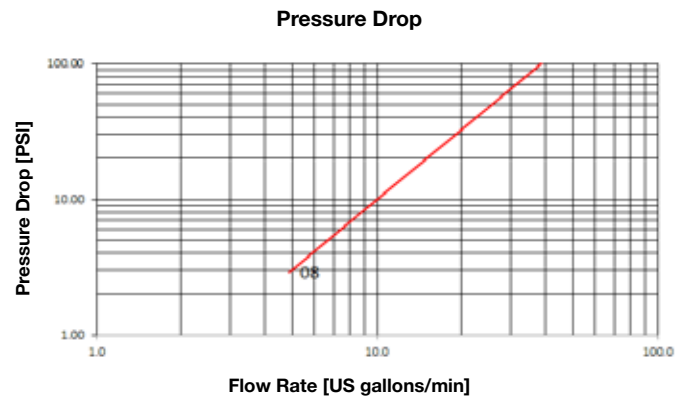
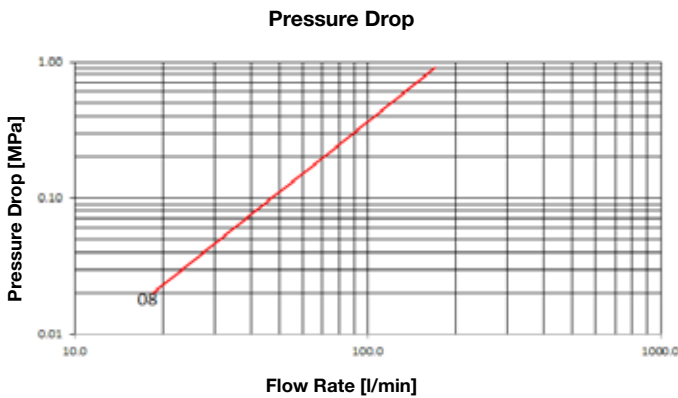

### Product description:

- Connectable with male (ISO A) and female under pressure
- High working pressure 30MPa
- Simple connection and disconnection by pulling back the sleeve
- No shut-off, Manuli mechanical valve block system
- Installations on hoses, pipe and direct to port
- Wide range of termination ends
- Interchangeable according to ISO 7241-1 part A

<b>Material</b>	Female couplings in steel, with some hardened areas, in correspondence to the most stressed points. Carbonitrided valves and sleeve, springs in C98 steel, seals in NBR and polyurethane (other materials on request) and back-up ring in PTFE
<b>Working Temperature</b>	-22°F up to +230°F (-30°C up to +110°C) For other temperatures, the quick coupling is assembled with specific seals
<b>Safety Factor</b>	4:1 for dynamic pressures
<b>Impulse Pressures</b>	500,000 cycles (connected and disconnected conditions) at 120% of the rated one (freq. 1Hz)
<b>Test Specifications</b>	ISO 7241-2



ISO A BOTH PARTS CONNECTABLE UNDER PRESSURE - TERMINATION ENDS

BSP

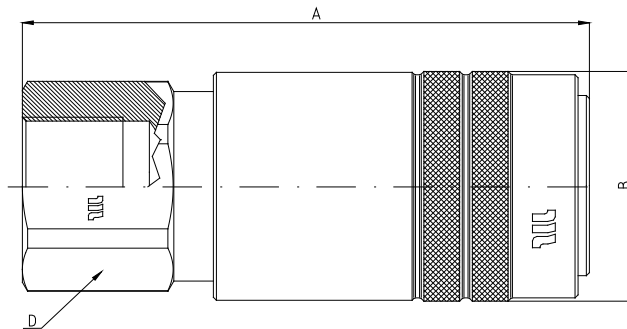

## Q01211041A

BSP TERMINATION ENDS

TO DIN3852

SIZE			PART NUMBER	THREAD	DIMENSIONS mm					
DN	inch	Size	Female coupling		A	B	D			
12.5	1/2"	-08	Q01211041A-08-08	1/2"	93.6	ø38,3	32			

METRIC

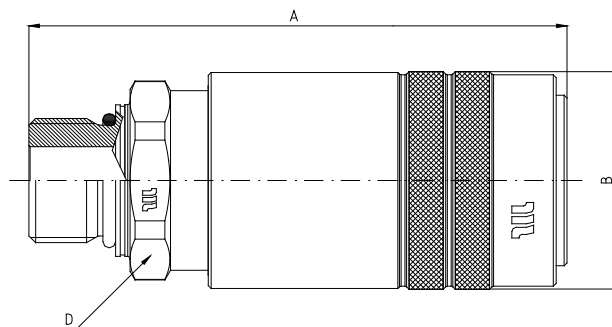

## Q01211190A

METRIC TERMINATION ENDS

TO ISO 6149-2

SIZE			PART NUMBER	THREAD	DIMENSIONS mm					
DN	inch	Size	Female coupling		A	B	D			
12.5	1/2"	-08	Q01211190A-08-22	M22x1,5	93.1	ø38,3	32			







## ISO B POPPET VALVES

<b>SIZE</b>	<b>WORKING PRESSURE (Dynamic)</b>	<b>RATED FLOW at 0.2 MPa of pressure drop</b>	<b>CONNECTION EFFORT</b>	<b>OIL SPILLAGE Connection/ Disconnection</b>	<b>MINIMUM BURST PRESSURE</b>	<b>CONNECTION/ DISCONNECTION UNDER PRESSURE</b>

mm	inch	dash	MPa	PSI	l/min	US GPM	N	lb.	cc.	cubic inch	Male		Female		M & F		
											MPa	PSI	MPa	PSI	MPa	PSI	
5	1/8	02	50	7250	5	1.3	40	9.0	0.5	0.031	210	30450	270	39150	220	31900	Not allowed
6.3	1/4	04	40	5800	16	4.3	40	9.0	0.8	0.049	180	26100	190	27550	165	23925	Not allowed
10	3/8	06	35	5075	51	13.5	40	9.0	1.5	0.092	145	21025	160	23200	160	23200	Not allowed
12.5	1/2	08	35	5075	84	22.0	70	15.7	2.5	0.153	145	21025	145	21025	160	23200	Not allowed
20	3/4	12	25	3625	156	41.5	90	20.2	8.5	0.519	100	14500	100	14500	125	18125	Not allowed
25	1	16	25	3625	246	65.0	90	20.2	15.0	0.915	100	14500	100	14500	120	17400	Not allowed

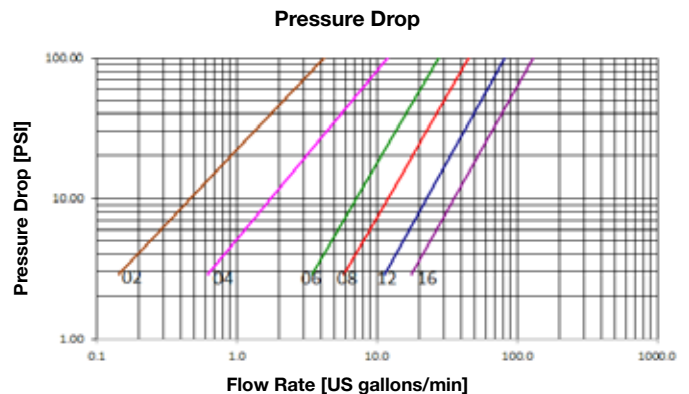
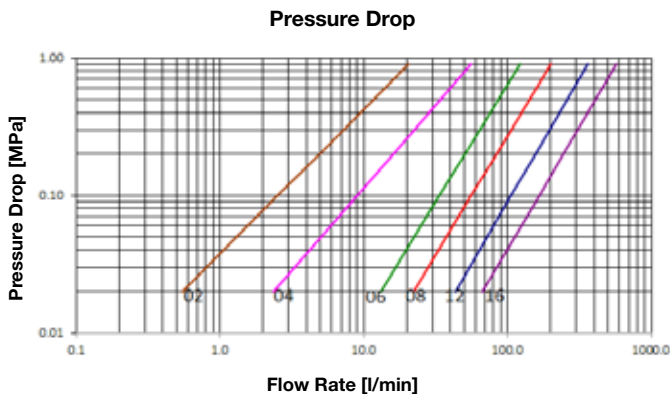

### Product description:

- Reference series for all industrial applications
- Simple connection and disconnection by pulling back the sleeve
- Positive, quick connection of the male into the female by latching the ball system
- Shut-off by poppet valve
- High resistant materials
- Interchangeable according to ISO 7241-1 series B

<b>Material</b>	Female couplings in steel, with some hardened areas, in correspondence to the most stressed points. Male couplings in high grade carbon steel hardened. Springs in C98 steel, seals in NBR (other materials on request) and back-up ring in PTFE
<b>Working Temperature</b>	-22°F up to +230°F (-30°C up to +110°C) For other temperatures, the quick coupling is assembled with specific seals
<b>Safety Factor</b>	4:1 for dynamic pressures
<b>Impulse Pressures</b>	Withstands 100,000 cycles of impulse pressure at 133% of the rated one (freq. 1Hz)
<b>Test Specifications</b>	ISO 7241-2



## ISO B POPPET VALVES - TERMINATION ENDS

**BSP**

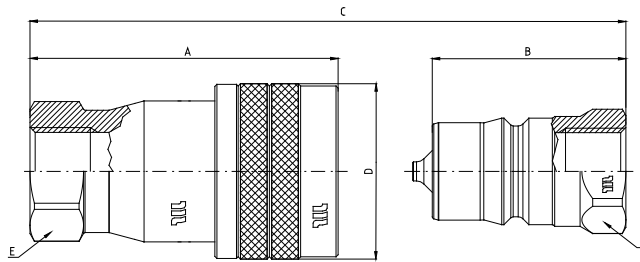

**Q02411041A**

**Q02111041A**

**BSP TERMINATION ENDS**

**TO DIN 3852 X TYPE**

SIZE			PART NUMBER		THREAD	DIMENSIONS mm					
DN	inch	Size	Female coupling	Male coupling		A	B	C	D	E	F
5	1/8"	-02	Q02411041A-02-02	Q02111041A-02-02	1/8"	48.5	30	A+B-18,7	ø22	15	14
6.3	1/4"	-04	Q02411041A-04-04	Q02111041A-04-04	1/4"	58.8	37.2	A+B-21,2	ø28	19	19
10	3/8"	-06	Q02411041A-06-06	Q00211041A-06-06	3/8"	66.2	41.5	A+B-24,4	ø35	24	22
12.5	1/2"	-08	Q02411041A-08-08	Q02111041A-08-08	1/2"	74	46.5	A+B-27,2	ø42	30	27
20	3/4"	-12	Q02411041A-12-12	Q02111041A-12-12	3/4"	91	56.5	A+B-34,2	ø52	36	36
25	1"	-16	Q02411041A-16-16	Q02111041A-16-16	1"	104	64.5	A+B-39,2	ø60	41	41

**NPT**

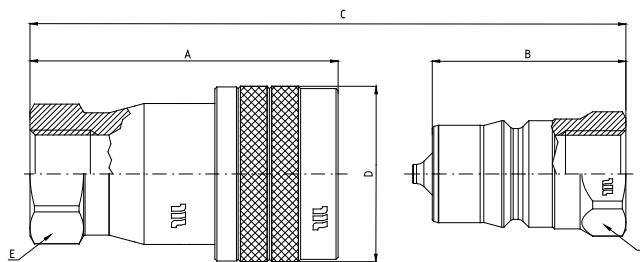

**Q02411341A**

**Q02111341A**

**NPTF TERMINATION END**

**TO ANSI B 1.20.3**

SIZE			PART NUMBER		THREAD	DIMENSIONS mm					
DN	inch	Size	Female coupling	Male coupling		A	B	C	D	E	F
5	1/8"	-02	Q02411341A-02-02	Q02111341A-02-02	1/8" NPTF	48.5	30	A+B-18,7	ø22	15	14
6.3	1/4"	-04	Q02411341A-04-04	Q02111341A-04-04	1/4" NPTF	58.8	37.2	A+B-21,2	ø28	19	19
10	3/8"	-06	Q02411341A-06-06	Q02111341A-06-06	3/8" NPTF	66.2	41.5	A+B-24,4	ø35	24	22
12.5	1/2"	-08	Q02411341A-08-08	Q02111341A-08-08	1/2" NPTF	74	46.5	A+B-27,2	ø42	30	27
20	3/4"	-12	Q02411341A-12-12	Q02111341A-12-12	3/4" NPTF	91	56.5	A+B-34,2	ø52	36	36
25	1"	-16	Q02411341A-16-16	Q02111341A-16-16	1" NPTF	104	64.5	A+B-39,2	ø60	41	41

SAE

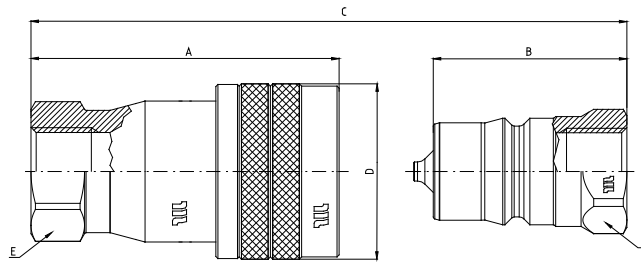

**Q02411301A**

**Q02111301A**

**SAE TERMINATION ENDS**

**TO SAE J1926-1**

SIZE			PART NUMBER		THREAD	DIMENSIONS mm					
DN	inch	Size	Female coupling	Male coupling		A	B	C	D	E	F
6.3	1/4"	-04	Q02411301A-04-06	Q02111301A-04-06	9/16"-18UNF	62.2	40.6	A+B-21,2	ø28	19	19
10	3/8"	-06	Q02411301A-06-08	Q00211301A-06-08	3/4"-16 UNF	68.2	46	A+B-24,4	ø35	24	24
12.5	1/2"	-08	Q02411301A-08-08	Q02111301A-08-08	3/4"-16 UNF	74	46.5	A+B-27,2	ø42	30	27
20	3/4"	-12	Q02411301A-12-12	Q02111301A-12-12	1"1/16-12 UN	94	59.5	A+B-34,2	ø52	36	34
25	1"	-16	Q02411301A-16-16	Q02111301A-16-16	1"5/16-12 UN	104	64.5	A+B-39,2	ø60	41	41



	<b>MPa</b>		<b>N</b>			
<b>SIZE</b>	<b>WORKING PRESSURE (Dynamic)</b>	<b>RATED FLOW at 0.2 MPa of pressure drop</b>	<b>CONNECTION EFFORT</b>	<b>OIL SPILLAGE Connection/ Disconnection</b>	<b>MINIMUM BURST PRESSURE</b>	<b>CONNECTION/ DISCONNECTION UNDER PRESSURE</b>

mm	inch	dash	MPa	PSI	l/min	US GPM	N	lb.	cc.	cubic inch	Male		Female		M & F		
											MPa	PSI	MPa	PSI	MPa	PSI	
12.5	½	08	42	6090	51	13.5	70	156	2.5	0.153	140	20300	140	20300	180	26100	Not allowed
20	¾	12	35	5075	102	26.9	90	200	8.5	0.519	100	14500	100	14500	150	21750	Not allowed
25	1	16	35	5075	170	44.9	90	200	15	0.916	100	14500	100	14500	140	20300	Not allowed

Pressure Drop

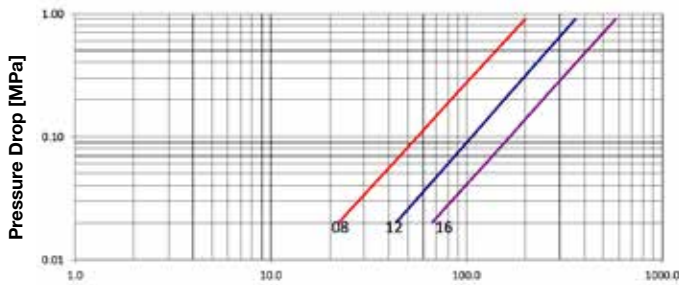

Flow Rate [l/min]

Pressure Drop

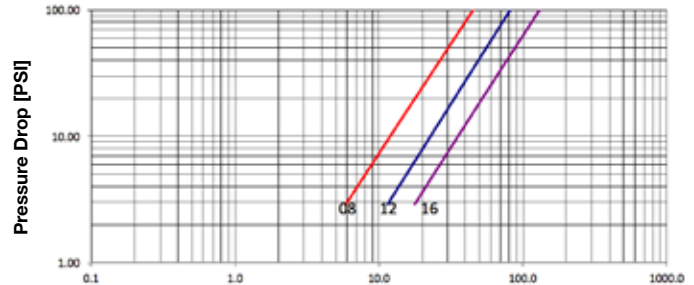

Flow Rate [US gallons/min]

### Product description:

- MQS-B BOP VERSION is designed for BOP (Blow-out preventer) service in Oil & Gas Industry
- Simple connection & disconnection by pulling back the sleeve
- Safety system on the female part to avoid accidental disconnection
- Positive quick connection of the male into the female by latching ball system
- Poppet valve sealing system that guarantee high sealing performance at low & high pressure
- ECOAT zinc plating with improved corrosion protection and environmentally friendly process
- Female & Male Coupling with red identification for an easy visual verification
- ISO 7241-1 series B interchangeable
- API 16D approval.

<b>Material</b>	Female & male couplings in high grade carbon steel with hardened areas in correspondence to the most stressed points. Seal in Viton with back-up in PTFE.
<b>Working Temperature</b>	-25°C to +200°C
<b>Safety Factor</b>	4.1 in CONNECTED & DISCONNECTED conditions
<b>Impulse Pressures</b>	Withstands 100,000 cycles of impulse pressure at 133% of the rated one (freq. 1Hz)
<b>Test Specifications</b>	ISO 7241-2 , Flame resistance test to API 16D



NPT

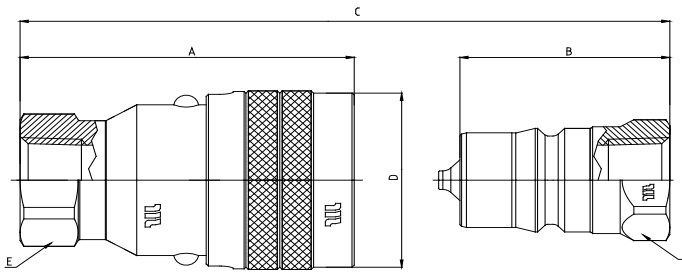

**Q02613341F**

**Q02113341F**

**NPTF TERMINATION ENDS**

**TO ANSI B1.20.3**

SIZE			PART NUMBER		THREAD	DIMENSIONS mm					
DN	inch	Size	Female coupling	Male coupling		A	B	C	D	E	F
12.5	1/2"	-08	Q02613341F-08-08	Q02113341F-08-08	1/2" NPTF	74	46.5	A+B-27,2	ø44	30	27
20	3/4"	-12	Q02613341F-12-12	Q02113341F-12-12	3/4" NPTF	91	56.5	A+B-34,2	ø54	36	34
25	1"	-16	Q02613341F-16-16	Q02113341F-16-16	1" NPTF	104	64.5	A+B-39,2	ø64	46	41





## STANDARD POPPET VALVE



<b>SIZE</b>	<b>WORKING PRESSURE (Dynamic)</b>	<b>RATED FLOW at 0.2 MPa of pressure drop</b>	<b>CONNECTION EFFORT</b>	<b>OIL SPILLAGE Connection/ Disconnection</b>	<b>MINIMUM BURST PRESSURE</b>	<b>CONNECTION/ DISCONNECTION UNDER PRESSURE</b>

mm	inch	dash	MPa	PSI	l/min	US GPM	N	lb.	cc.	cubic inch	Male		Female		M & F		
											MPa	PSI	MPa	PSI	MPa	PSI	
6.3	¼	04	35	5075	16	4.2	40	89	0.8	0.049	190	27500	190	27500	140	20300	Not allowed
10	⅜	06	35	5075	49	12.9	65	144	1.3	0.079	150	21750	160	23200	160	23200	Not allowed
12.5	½	08	See ISO A Series														
20	¾	12	25	3625	135	35.7	80	178	7	0.427	110	15950	100	14500	120	17400	Not allowed
25	1	16	25	3625	196	51.8	90	200	11	0.672	100	14500	110	15950	120	17400	Not allowed
31.5	1¼	20	22	3190	376	99.3	105	233	15	0.916	90	13050	90	13050	100	14500	Not allowed
40	1½	24	21	3045	536	141.6	115	256	24	1.465	85	12325	90	13050	100	14500	Not allowed

Pressure Drop

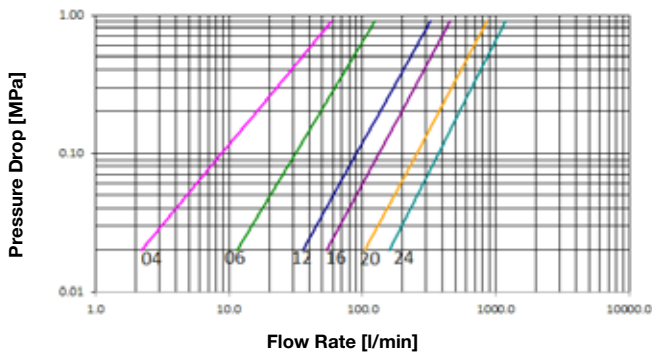

Pressure Drop

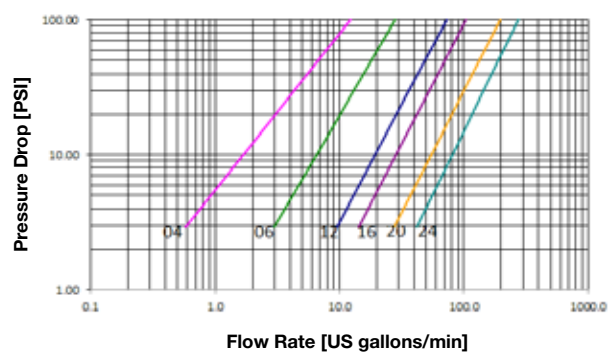

### Product description:

- Historical series for the agriculture market
- Simple connection and disconnection by pulling back the sleeve
- Positive, quick connection of the male into the female by latching the ball system
- Shut-off by poppet valve
- High resistant materials
- Interchangeable with similar products available on the market (½" size according to ISO 7241-1 series A)

<b>Material</b>	Female couplings in steel, with some hardened areas, in correspondence to the most stressed points. Male couplings in high grade carbon steel hardened. Springs in C98 steel, seals in NBR (other materials on request) and back-up ring in PTFE
<b>Working Temperature</b>	-22°F up to +230°F (-30°C up to +110°C) For other temperatures, the quick coupling is assembled with specific seals
<b>Safety Factor</b>	4:1 for dynamic pressures
<b>Impulse Pressures</b>	100,000 cycles at 133% of the rated one (freq. 1Hz)
<b>Test Specifications</b>	ISO 7241-2



BSP

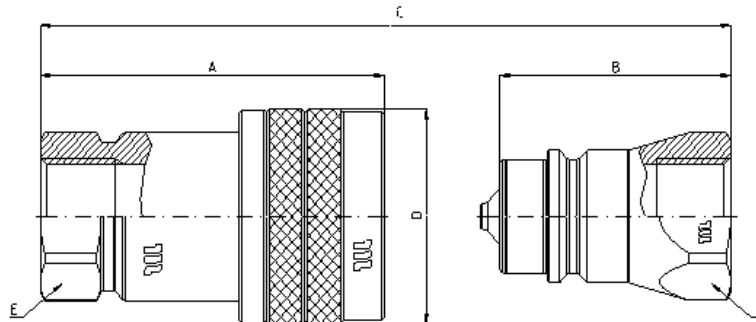

**Q03211041A**

**Q02911041A**

**BSP TERMINATION ENDS**

**TO DIN 3852 X TYPE**

SIZE			PART NUMBER		THREAD	DIMENSIONS mm								
DN	inch	Size	Female coupling	Male coupling		A	B	C	D	E	F			
6.3	1/4"	-04	Q03211041A-04-04	Q02911041A-04-04	1/4"	53.5	36.5	A+B-16,6	ø27	19	19			
10	3/8"	-06	Q03211041A-06-06	Q02911041A-06-06	3/8"	60.5	40	A+B-20,1	ø34	24	24			
12.5	1/2"	-08	SEE ISO SERIES A											
20	3/4"	-12	Q03211041A-12-12	Q02911041A-12-12	3/4"	85.5	56.5	A+B-28,3	ø47	34	34			
25	1"	-16	Q03211041A-16-16	Q02911041A-16-16	1"	98	64.5	A+B-32,9	ø52	41	41			
31.5	1.1/4"	-20	Q03211041A-20-20	Q02911041A-20-20	1.1/4"	119.5	78	A+B-41,5	ø68	50	50			
40	1.1/2"	-24	Q03211041A-24-24	Q02911041A-24-24	1.2/2"	132	88	A+B-44,2	ø80	60	60			

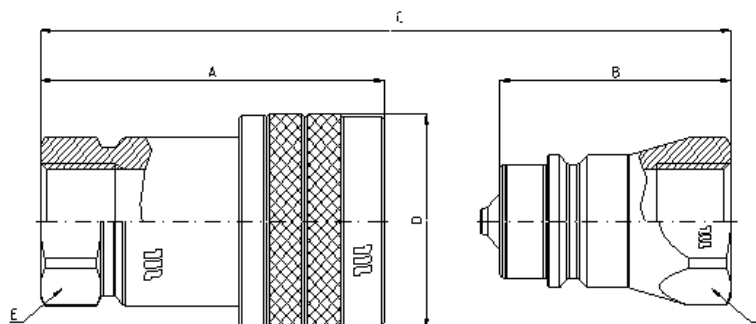

**Q03211041B**

**Q02911041B**

**BSP TERMINATION ENDS**

**TO DIN 3852 X TYPE**

SIZE			PART NUMBER		THREAD	DIMENSIONS mm							
DN	inch	Size	Female coupling	Male coupling		A	B	C	D	E	F		
20	3/4"	-12	Q03211041B-12-12	Q02911041B-12-12	3/4"	88	56.5	A+B-31	ø47	34	34		
25	1"	-16	Q03211041B-16-16	Q02911041B-16-16	1"	98	64.5	A+B-32,9	ø52	41	41		

NPT

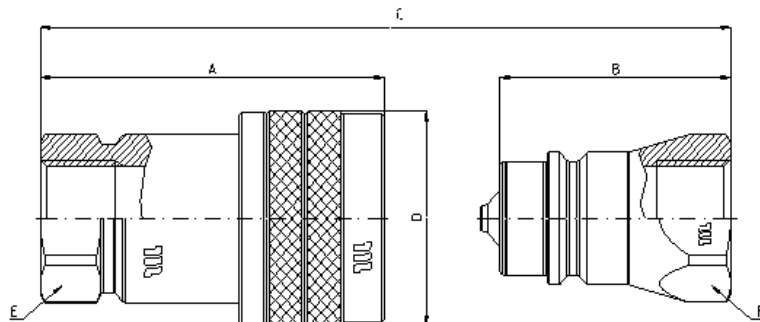

**Q03211341A**

**Q02911341A**

**NPTF TERMINATION END  
TO ANSI B 1.20.3**

SIZE			PART NUMBER		THREAD	DIMENSIONS mm							
DN	inch	Size	Female coupling	Male coupling		A	B	C	D	E	F		
6.3	1/4"	-04	Q03211341A-04-04	Q02911341A-04-04	1/4" NPTF	53.5	36.5	A+B-16,6	ø27	19	19		
10	3/8"	-06	Q03211341A-06-06	Q02911341A-06-06	3/8" NPTF	60.5	40	A+B-20,1	ø34	24	24		
12.5	1/2"	-08	SEE ISO SERIES A										
20	3/4"	-12	Q03211341A-12-12	Q02911341A-12-12	3/4" NPTF	85.5	56.5	A+B-28,3	ø47	34	34		
25	1"	-16	Q03211341A-16-16	Q02911341A-16-16	1" NPTF	98	64.5	A+B-32,9	ø52	41	41		
31.5	1.1/4"	-20	Q03211341A-20-20	Q02911341A-20-20	1.1/4"	119.5	78	A+B-41,5	ø68	50	50		
40	1.1/2"	-24	Q03211341A-24-24	Q02911341A-24-24	1.2/2"	132	88	A+B-44,2	ø80	60	60		

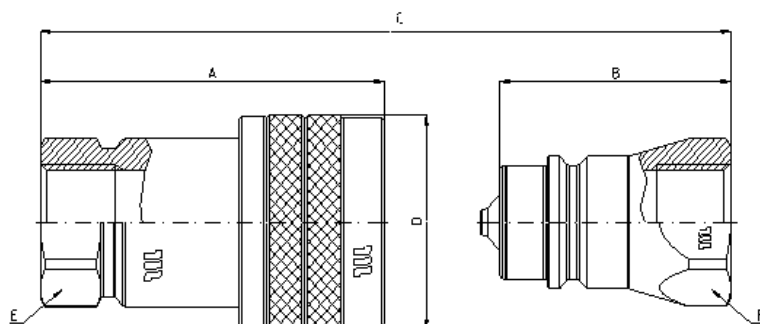

**Q03211341B**

**Q02911341B**

**NPTF TERMINATION END  
TO ANSI B 1.20.3**

SIZE			PART NUMBER		THREAD	DIMENSIONS mm							
DN	inch	Size	Female coupling	Male coupling		A	B	C	D	E	F		
20	3/4"	-12	Q03211341B-12-12	Q02911341B-12-12	3/4" NPTF	88	56.5	A+B-31	ø47	34	34		
25	1"	-16	Q03211341B-16-16	Q02911341B-16-16	1" NPTF	98	64.5	A+B-32,9	ø52	41	41		



<b>SIZE</b>	<b>WORKING PRESSURE (Dynamic)</b>	<b>RATED FLOW at 0.2 MPa of pressure drop</b>	<b>CONNECTION EFFORT</b>	<b>OIL SPILLAGE Connection/ Disconnection</b>	<b>MINIMUM BURST PRESSURE</b>	<b>CONNECTION/ DISCONNECTION UNDER PRESSURE</b>

mm	inch	dash	MPa	PSI	l/min	US GPM	N	lb.	cc.	cubic inch	Male		Female		M & F		
											MPa	PSI	MPa	PSI	MPa	PSI	
6.3	¼	04	30	4350	9	2.4	40	89	0.35	0.021	140	20300	125	18125	150	21750	Not allowed
10	¾	06	25	3625	28	7.4	65	144	0.85	0.052	115	16675	120	17400	160	23200	Not allowed
12.5	½	08	See ISO A Series sealed ball														
20	¾	12	25	3625	74	19.6	75	167	3.5	0.214	100	14500	110	15950	125	18125	Not allowed
25	1	16	21	3045	114	30.1	100	222	5	0.305	85	12325	100	14500	110	15950	Not allowed

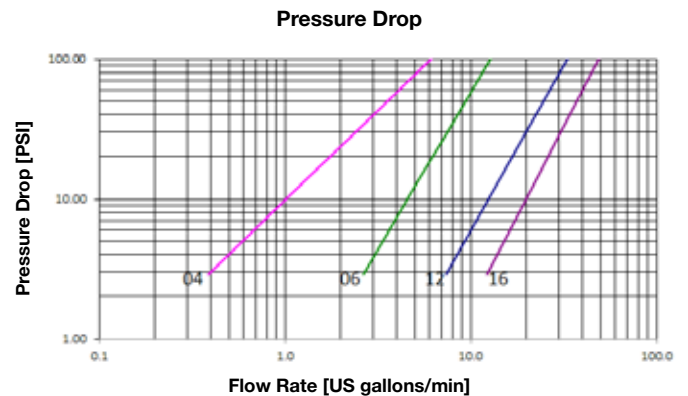
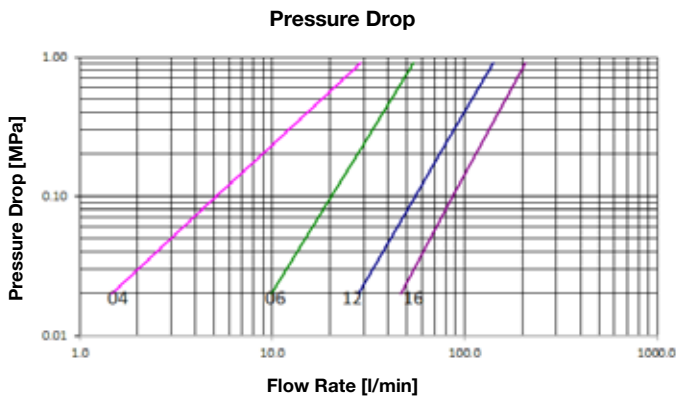

### Product description:

- Historical series for the agriculture market
- Simple connection and disconnection by pulling back the sleeve
- Positive, quick connection of the male into the female by latching the ball system
- Shut-off by ball valve
- High resistant materials
- Interchangeable with poppet valve standard series and with similar products available on the market (½" size according to ISO 7241-1 series A)

<b>Material</b>	Female couplings in steel, with some hardened areas, in correspondence to the most stressed points. Male couplings in high grade carbon steel hardened. High-resistance latching balls, springs in C98 steel, seals in NBR and back-up ring in PTFE
<b>Working Temperature</b>	-22°F up to +230°F (-30°C up to +110°C) For other temperatures, the quick coupling is assembled with specific seals
<b>Safety Factor</b>	4:1 for dynamic pressures
<b>Impulse Pressures</b>	100,000 cycles at 133% of the rated one (freq. 1Hz)
<b>Test Specifications</b>	ISO 7241-2



## STANDARD (BALL) - TERMINATION ENDS

BSP

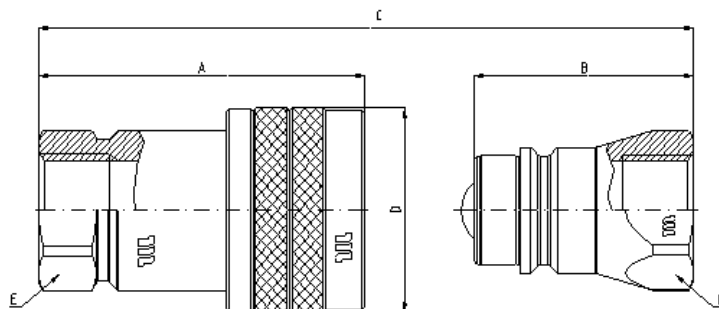

**Q03311041A**

**Q03010041A**

**BSP TERMINATION ENDS**

**TO DIN 3852 X TYPE**

SIZE			PART NUMBER		THREAD	DIMENSIONS mm							
DN	inch	Size	Female coupling	Male coupling		A	B	C	D	E	F		
6.3	1/4"	-04	Q03311041A-04-04	Q03010041A-04-04	1/4"	51.3	34.3	A+B-16,6	ø27	19	19		
10	3/8"	-06	Q03311041A-06-06	Q03010041A-06-06	3/8"	59.9	39.4	A+B-20,1	ø34	24	24		
12.5	1/2"	-08	SEE ISO SERIES A										
20	3/4"	-12	Q03311041A-12-12	Q03010041A-12-12	3/4"	85.5	56.5	A+B-28,3	ø47	34	34		
25	1"	-16	Q03311041A-16-16	Q03010041A-16-16	1"	98	64.5	A+B-32,9	ø52	41	41		

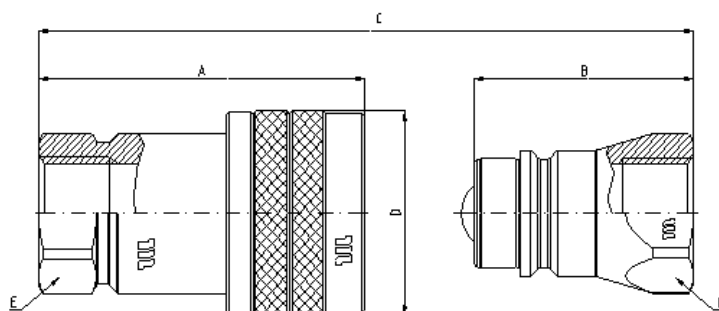

**Q03311041B**

**Q03010041B**

**BSP TERMINATION ENDS**

**TO DIN 3852 X TYPE**

SIZE			PART NUMBER		THREAD	DIMENSIONS mm							
DN	inch	Size	Female coupling	Male coupling		A	B	C	D	E	F		
20	3/4"	-12	Q03311041B-12-12	Q03010041B-12-12	3/4"	88	58.5	A+B-31,5	ø47	34	34		

NPT

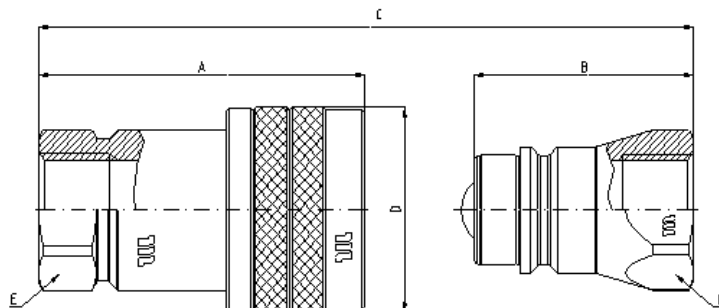

**Q03311341A**

**Q03010341A**

**NPTF TERMINATION END**

**TO ANSI B 1.20.3**

SIZE			PART NUMBER		THREAD	DIMENSIONS mm							
DN	inch	Size	Female coupling	Male coupling		A	B	C	D	E	F		
6.3	1/4"	-04	Q03311341A-04-04	Q03010341A-04-04	1/4" NPTF	51.3	34.3	A+B-16,6	ø27	19	19		
10	3/8"	-06	Q03311341A-06-06	Q03010341A-06-06	3/8" NPTF	59.9	39.4	A+B-20,1	ø34	24	24		
12.5	1/2"	-08	SEE ISO SERIES A										
20	3/4"	-12	Q03311341A-12-12	Q03010341A-12-12	3/4" NPTF	85.5	56.5	A+B-28,3	ø47	34	34		
25	1"	-16	Q03311341A-16-16	Q03010341A-16-16	1" NPTF	98	64.5	A+B-32,9	ø52	41	41		

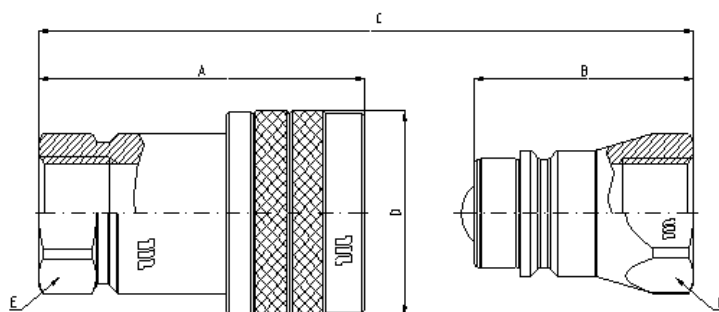

**Q03311341B**

**Q03010341B**





**NPTF TERMINATION END**

**TO ANSI B 1.20.3**

SIZE			PART NUMBER		THREAD	DIMENSIONS mm							
DN	inch	Size	Female coupling	Male coupling		A	B	C	D	E	F		
6.3	1/4"	-04	Q03311341B-12-12	Q03010341B-12-12	3/4" NPTF	88	58.5	A+B-31,5	ø47	34	34		





			
<b>SIZE</b>	<b>WORKING PRESSURE (Dynamic)</b>	<b>MINIMUM BURST PRESSURE</b>	<b>CONNECTION/ DISCONNECTION UNDER PRESSURE</b>

mm	inch	dash	MPa	PSI	M & F		
					MPa	PSI	
6.3	¼	04	35	5075	160	23200	Not allowed
10	¾	06	35	5075	145	21025	Not allowed
12.5	½	08	35	5075	145	21025	Not allowed

### Product description:

- MQS-NL is Compact Free-Flow quick release couplings
- Simple connection & disconnection by pulling back the sleeve
- Positive quick connection of the male into the female by latching ball system
- ECOAT zinc plating with improved corrosion protection and environmentally friendly process

<b>Material</b>	Female & male couplings in high grade carbon steel with hardened areas in correspondence to the most stressed points. Seal in NBR with back-up in PTFE.
<b>Working Temperature</b>	-30°C to +110°C
<b>Safety Factor</b>	4.1 in CONNECTED & DISCONNECTED conditions
<b>Impulse Pressures</b>	100,000 cycles at 133% of the rated one (freq. 1Hz)
<b>Test Specifications</b>	ISO 7241-2



BSP

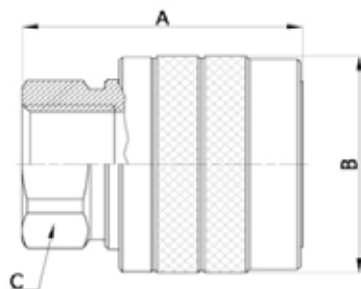

### Q00381041

BSP TERMINATION ENDS  
TO DIN 3852 X TYPE

SIZE			PART NUMBER	THREAD	DIMENSIONS mm								
DN	inch	Size	Female coupling		A	B	C						
6.3	1/4"	-04	Q03811041A-04-04	1/4"	33.2	27.5	19						
10	3/8"	-06	Q03811041A-06-06	3/8"	39.5	34.3	24						
12.5	1/2"	-08	Q03811041A-08-08	1/2"	44	38.3	27						

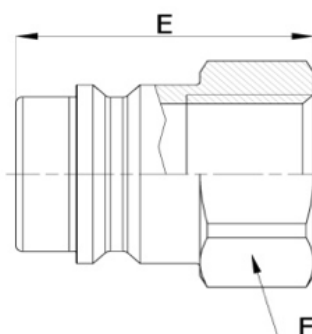

### Q03710041

BSP TERMINATION ENDS  
TO DIN 3852 X TYPE

SIZE			PART NUMBER	THREAD	DIMENSIONS mm								
DN	inch	Size	Male coupling		E	F							
6.3	1/4"	-04	Q03710041A-04-04	1/4"	27.5	19							
10	3/8"	-06	Q03710041A-06-06	3/8"	29	24							
12.5	1/2"	-08	Q03710041A-08-08	1/2"	34	27							



## STANDARD PUSH-PULL



<b>SIZE</b>	<b>WORKING PRESSURE (Dynamic)</b>	<b>RATED FLOW at 0.2 MPa of pressure drop</b>	<b>CONNECTION EFFORT</b>	<b>OIL SPILLAGE Connection/ Disconnection</b>	<b>MINIMUM BURST PRESSURE</b>	<b>CONNECTION/ DISCONNECTION UNDER PRESSURE</b>

mm	inch	dash	MPa	PSI	l/min	US GPM	N	lb.	cc.	cubic inch	Female		M & F		
											MPa	PSI	MPa	PSI	
6.3	¼	04	35	5075	16	4.2	65	144	0.8	0.049	230	33350	140	20300	Not allowed
10	¾	06	35	5075	49	12.9	100	222	1.3	0.079	170	24650	150	21750	Not allowed
12.5	½	08	See ISO A Series												

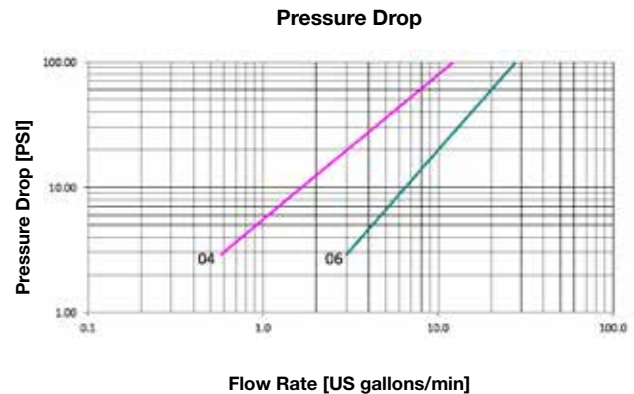
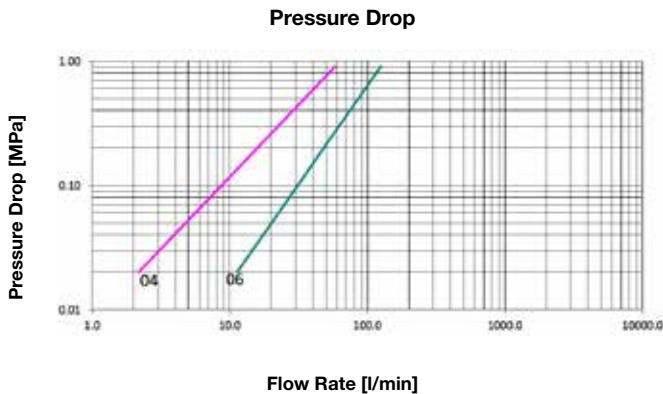

### Product description:

- Female couplings designed for Agriculture applications, interchangeable with male part MQS-N
- Push-Pull connection/disconnection
- Break-away function according to ISO 5675 (in case of bulkhead mounting on the external sleeve)
- Positive connection by latching ball system
- Shut-off by poppet valve

<b>Material</b>	Female & male couplings in high grade carbon steel with hardened areas in correspondence to the most stressed points. Seal in NBR with back-up in PTFE.
<b>Working Temperature</b>	-30°C to +110°C
<b>Safety Factor</b>	4.1 in CONNECTED & DISCONNECTED conditions
<b>Impulse Pressures</b>	100,000 cycles at 133% of the rated one (freq. 1Hz)
<b>Test Specifications</b>	ISO 7241-2



## STANDARD PUSH-PULL - TERMINATION ENDS

BSP

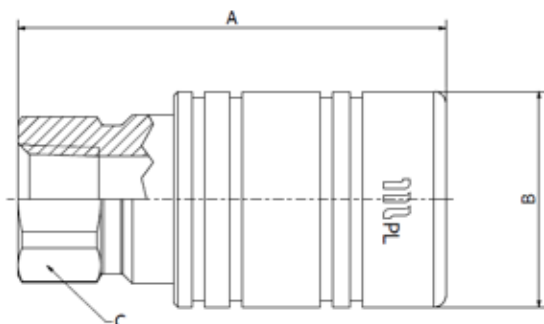

### Q03611041A

BSP TERMINATION ENDS  
TO DIN 3852 X TYPE

SIZE			PART NUMBER	THREAD	DIMENSIONS mm					
DN	inch	Size	Female coupling		A	B	C			
6.3	1/4"	-04	Q03611041A-04-04	1/4"	53.5	ø27	19			
10	3/8"	-06	Q03611041A-06-06	3/8"	60.5	ø33	24			

NPT

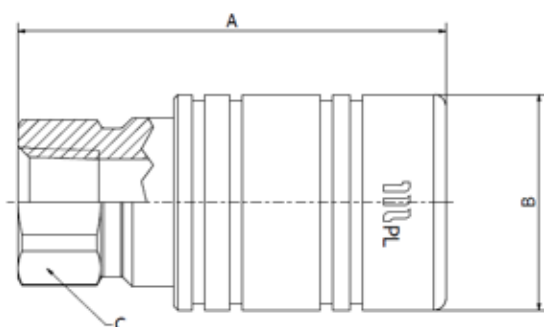

### Q03611341A

NPT TERMINATION ENDS  
TO ANSI B 1.20.3

SIZE			PART NUMBER	THREAD	DIMENSIONS mm					
DN	inch	Size	Female coupling		A	B	C			
6.3	1/4"	-04	Q03611341A-04-04	1/4"-NPT	53.5	ø27	19			
10	3/8"	-06	Q03611341A-06-06	3/8"-NPT	60.5	ø33	24			





## PUSH-PULL POPPET VALVES



<b>SIZE</b>	<b>WORKING PRESSURE (Dynamic)</b>	<b>RATED FLOW at 0.2 MPa of pressure drop</b>	<b>CONNECTION EFFORT</b>	<b>OIL SPILLAGE Connection/ Disconnection</b>	<b>MINIMUM BURST PRESSURE</b>		<b>CONNECTION/ DISCONNECTION UNDER PRESSURE</b>

mm	inch	dash	MPa	PSI	l/min	US GPM	N	lb.	cc.	cubic inch	Female		M & F		
											MPa	PSI	MPa	PSI	
6.3	¼	04	35	5075	5	1.3	80	178	0.7	0.043	180	26100	145	21025	Not allowed
10	⅜	06	31.5	4568	35	9.2	105	233	1.4	0.085	150	21750	130	18850	Not allowed
12.5	½	08	30	4350	68	18.0	110	244	2	0.122	140	20300	140	20300	Not allowed
20	¾	12	25	3625	147	38.8	165	367	4	0.244	120	17400	110	15950	Not allowed
25	1	16	25	3625	250	66.1	215	478	8.5	0.519	115	16675	120	17400	Not allowed

Pressure Drop

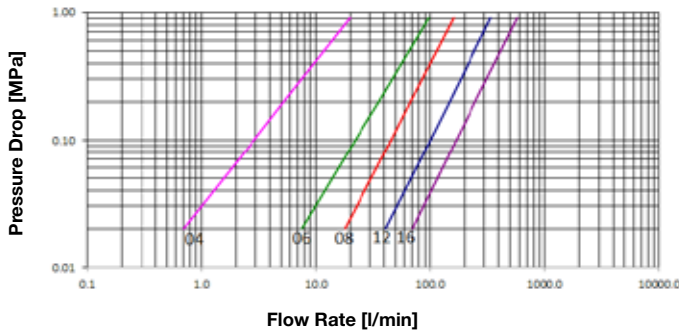

Pressure Drop

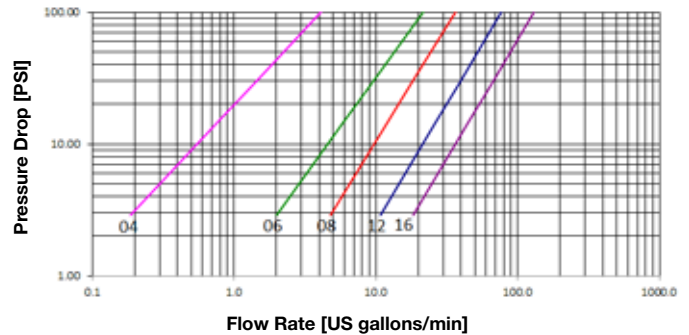

### Product description:

- Female coupling designed for agriculture applications, connectable with ISO 7241-1 series A male couplings
- PUSH-PULL connection and disconnection system, in case of bulkhead mounting on the external sleeve
- Break-away function according to ISO 5675 (in case of bulkhead mounting on the external sleeve)
- Positive connection by latching balls system
- Shut-off by poppet valve
- High resistant materials
- Dimensions and performances according to ISO 7241-1 series A

<b>Material</b>	Female couplings in steel with some hardened areas, in correspondence to the most stressed points. Carbonitrided valve and sleeve, springs in C98 steel, latching balls in high resistance 100 C6 steel, seals in NBR (other materials on request) and back-up ring in PTFE
<b>Working Temperature</b>	-22°F up to +230°F (-30°C up to +110°C) For other temperatures, the coupling is assembled with specific seals
<b>Safety Factor</b>	4:1 for dynamic pressures
<b>Impulse Pressures</b>	100,000 cycles at 133% of the rated one (freq. 1Hz)
<b>Test Specifications</b>	ISO 7241-2



## PUSH-PULL POPPET VALVES - TERMINATION ENDS

BSP

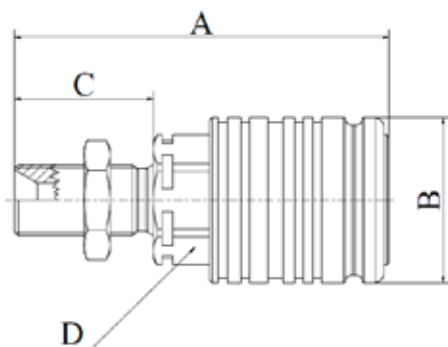

### Q01311040A

BSP TERMINATION ENDS

TO DIN3852

BULKHEAD

SIZE			PART NUMBER	THREAD	DIMENSIONS mm					
DN	inch	Size	Female coupling		A	B	C	D		
12.5	1/2"	-08	Q01311040A-08-06	3/8"	86.2	ø38	32	27		

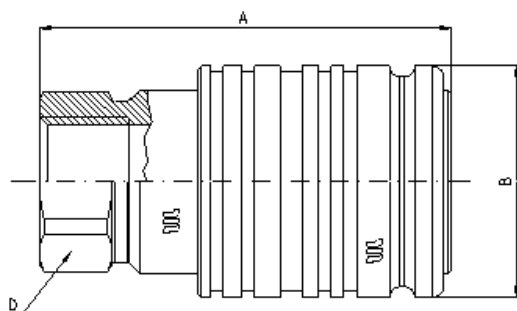

### Q01311041A

BSP TERMINATION ENDS

TO DIN 3852 X TYPE

SIZE			PART NUMBER	THREAD	DIMENSIONS mm					
DN	inch	Size	Female coupling		A	B	D			
6	1/4"	-04	Q01311041A-04-04	1/4"	58.1	ø26	17			
10	3/8"	-06	Q01311041A-06-04	1/4"	63	ø32	22			
			Q01311041A-06-06	3/8"	64.5	ø32	22			
12.5	1/2"	-08	Q01311041A-08-06	3/8"	66.2	ø38	27			
			Q01311041A-08-08	1/2"	67	ø38	27			
			Q01311041A-08-12	3/4"	73.2	ø38	34			
20	3/4"	-12	Q01311041A-12-12	3/4"	87.7	ø48	34			
25	1"	-16	Q01311041A-16-12	3/4"	97.9	ø54	41			
			Q01311041A-16-16	1"	97.9	ø54	41			

BSP

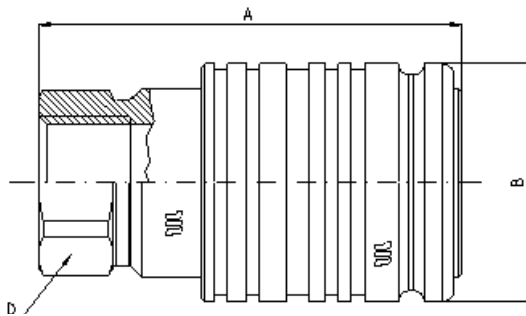

### Q01311041U

BSP TERMINATION ENDS

TO DIN 3852 X TYPE

SIZE			PART NUMBER	THREAD	DIMENSIONS mm					
DN	inch	Size	Female coupling		A	B	D			
12.5	1/2"	-08	Q01311041U-08-08	1/2"	67	ø38	27			

Polyurethane seal

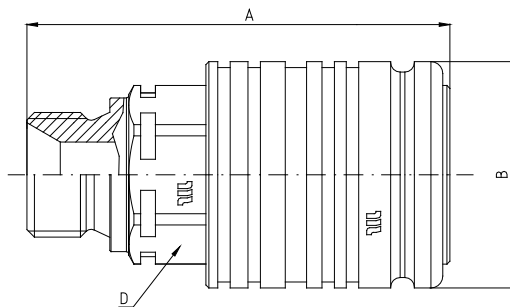

### Q01311050A

BSP TERMINATION ENDS

TO ISO 8434-6

SIZE			PART NUMBER	THREAD	DIMENSIONS mm					
DN	inch	Size	Female coupling		A	B	D			
12.5	1/2"	-08	Q01311050A-08-06	3/8"	68.9	ø38	27			
			Q01311050A-08-08	1/2"	71.4	ø38	27			

## PUSH-PULL POPPET VALVES - TERMINATION ENDS

METRIC

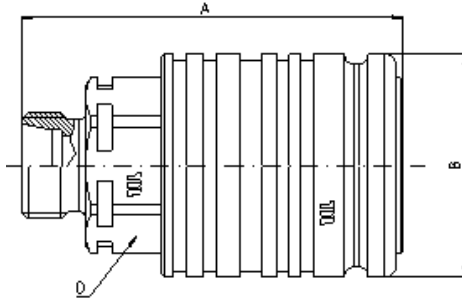

### Q01311110A

METRIC TERMINATION ENDS

TO ISO 8434-1

L SERIES

SIZE			PART NUMBER	THREAD	DIMENSIONS mm					
DN	inch	Size	Female coupling		A	B	D			
10	3/8"	-06	Q01311110A-06-12	M12x1,5	61	ø32	22			
			Q01311110A-06-14	M14x1,5	61	ø32	22			
			Q01311110A-06-16	M16x1,5	61	ø32	22			
			Q01311110A-06-18	M18x1,5	61	ø32	22			
12.5	1/2"	-08	Q01311110A-08-14	M14x1,5	65.2	ø38	27			
			Q01311110A-08-16	M16x1,5	66.2	ø38	27			
			Q01311110A-08-18	M18x1,5	65.2	ø38	27			
			Q01311110A-08-22	M22x1,5	66.2	ø38	27			
20	3/4"	-12	Q01311110A-08-26	M26x1,5	66.2	ø38	30			
			Q01311110A-12-22	M22x1,5	85.7	ø48	34			
			Q01311110A-12-26	M26x1,5	85.7	ø48	34			
25	1"	-16	Q01311110A-12-30	M30x2	87.7	ø48	34			
			Q01311110A-16-26	M26x1,5	94.5	ø54	41			
			Q01311110A-16-30	M30x2	96.5	ø54	41			
			Q01311110A-16-36	M36x2	96.5	ø54	41			

METRIC

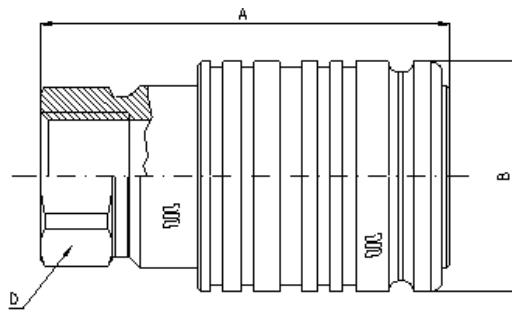

### Q0131141A

METRIC TERMINATION ENDS

TO DIN 3852 X TYPE

SIZE			PART NUMBER	THREAD	DIMENSIONS mm					
DN	inch	Size	Female coupling		A	B	D			
10	3/8"	-06	Q0131141A-06-16	M16x1,5	64.5	ø32	22			
12.5	1/2"	-08	Q0131141A-08-18	M18x1,5	66.2	ø38	27			
			Q0131141A-08-20	M20x1,5	67	ø38	27			
			Q0131141A-08-22	M22x1,5	67	ø38	27			
20	3/4"	-12	Q0131141A-12-22	M22x1,5	84.7	ø48	34			

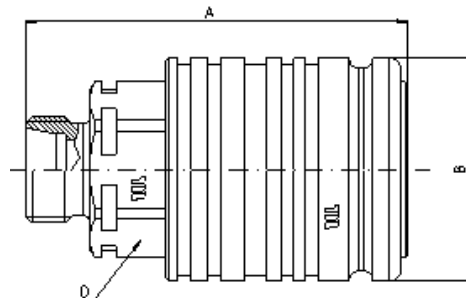

### Q0131120A

METRIC TERMINATION ENDS

TO ISO 8434-1

S SERIES

SIZE			PART NUMBER	THREAD	DIMENSIONS mm					
DN	inch	Size	Female coupling		A	B	D			
10	3/8"	-06	Q0131120A-06-16	M16x1,5	62	ø32	22			
			Q0131120A-06-18	M18x1,5	62	ø32	22			
12.5	1/2"	-08	Q0131120A-08-18	M18x1,5	66.2	ø38	27			
			Q0131120A-08-20	M20x1,5	66.2	ø38	27			
			Q0131120A-08-24	M24x1,5	68.2	ø38	27			
25	1"	-16	Q0081120A-16-30	M30x2	98.5	ø54	41			
			Q0081120A-16-36	M36x2	100.5	ø54	41			
			Q0081120A-16-42	M40x2	102.5	ø54	44			

## PUSH-PULL POPPET VALVES - TERMINATION ENDS

METRIC

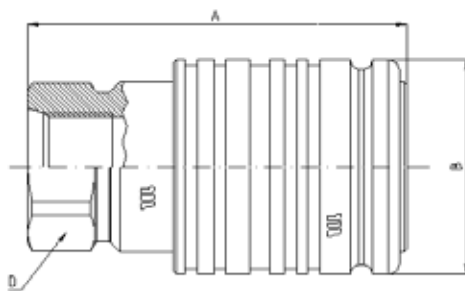

### Q0131191A

METRIC TERMINATION ENDS

TO DIN 3852 X TYPE

SIZE			PART NUMBER	THREAD	DIMENSIONS mm					
DN	inch	Size	Female coupling		A	B	D			
12.5	1/2"	-08	Q0131191A-08-16*	M16x1,5	66.7	ø38	27			
			Q0131191A-08-18*	M18x1,5	68.2	ø38	27			
			Q0131191A-08-22	M22x1,5	67	ø38	27			

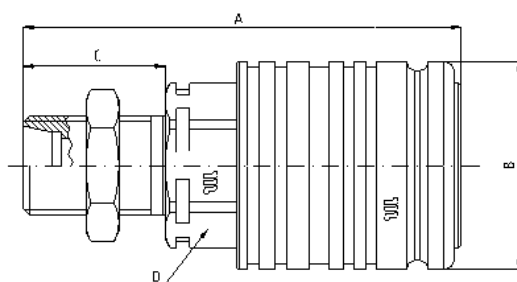

### Q01311770B

METRIC TERMINATION END

TO ISO 8434-1

BULKHEAD L SERIES

SIZE			PART NUMBER	THREAD	DIMENSIONS mm					
DN	inch	Size	Female coupling		A	B	C	D		
10	3/8"	-06	Q01311770B-06-12	M12x1,5	76	ø32	25	22		
			Q01311770B-06-14	M14x1,5	75	ø32	25	22		
			Q01311770B-06-16	M16x1,5	75	ø32	26	22		
			Q01311770B-06-18	M18x1,5	75	ø32	26	22		
12.5	1/2"	-08	Q01311770B-08-14	M14x1,5	80.2	ø38	25	27		
			Q01311770B-08-16	M16x1,5	80.2	ø38	26	27		
			Q01311770B-08-18	M18x1,5	80.2	ø38	26	27		
			Q01311770B-08-22	M22x1,5	81.2	ø38	27	27		
			Q01311770B-08-26	M26x1,5	82.2	ø38	28	30		
25	1"	-16	Q01311770B-16-30	M30x2	114.5	ø54	32	41		

METRIC

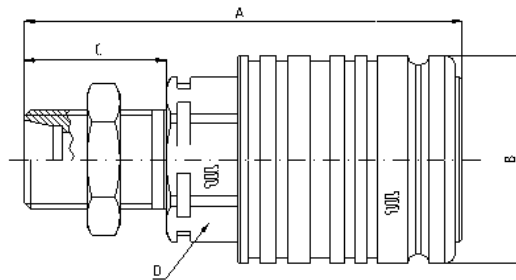

### Q01311870B

METRIC TERMINATION END

TO ISO 8434-1

BULKHEAD S SERIES

SIZE			PART NUMBER	THREAD	DIMENSIONS mm					
DN	inch	Size	Female coupling		A	B	C	D		
10	3/8"	-06	Q01311870B-06-16	M16x1,5	76	ø32	27	22		
			Q01311870B-06-18	M18x1,5	76	ø32	27	22		
12.5	1/2"	-08	Q01311870B-08-18	M18x1,5	81.2	ø38	27	27		
			Q01311870B-08-20	M20x1,5	81.2	ø38	27	27		
			Q01311870B-08-24	M24x1,5	83.2	ø38	29	27		

NPT

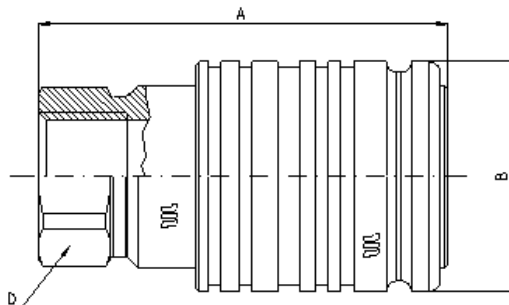

### Q01311341A

NPT TERMINATION END

TO ANSI B 1.20.3 STANDARD

SIZE			PART NUMBER	THREAD	DIMENSIONS mm					
DN	inch	Size	Female coupling		A	B	D			
6	1/4"	-04	Q01311341A-04-04	1/4" NPTF	58	ø26	17			
10	3/8"	-06	Q01311341A-06-06	3/8" NPTF	64.5	ø32	22			
12.5	1/2"	-08	Q01311341A-08-08	1/2" NPTF	67	ø38	27			
25	1"	-16	Q01311341A-16-16	1" NPTF	97.9	ø54	41			



## PUSH-PULL POPPET VALVES - TERMINATION ENDS

SAE

### Q01311301A

BSP TERMINATION ENDS  
TO DIN 3852 X TYPE

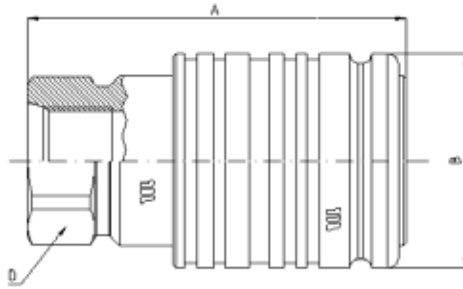

SIZE			PART NUMBER	THREAD	DIMENSIONS mm					
DN	inch	Size	Female coupling		A	B	D			
10	3/8"	-06	Q01311301A-06-06*	9/16"-18 UNF	64.5	ø32	22			
12.5	1/2"	-08	Q01311301A-08-08	3/4"-16 UNF	67	ø38	27			
			Q01311301A-08-10	7/8"-14 UNF	69	ø38	27			

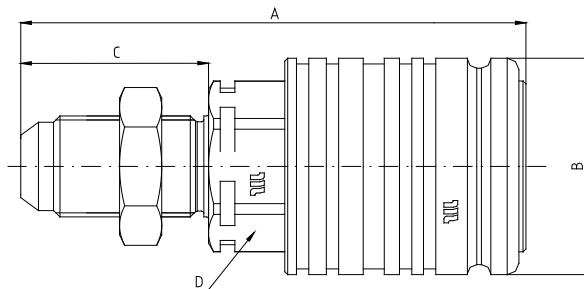

### Q01311230A

SAE TERMINATION END  
TO ISO 8434-2  
BULKHEAD

SIZE			PART NUMBER	THREAD	DIMENSIONS mm					
DN	inch	Size	Female coupling		A	B	C	D		
12.5	1/2"	-08	Q01311230A-08-08	3/4"-16 UNF	91.8	ø38	37.6	27		
			Q01311230A-08-10	7/8"-14 UNF	95.3	ø38	41.1	27		

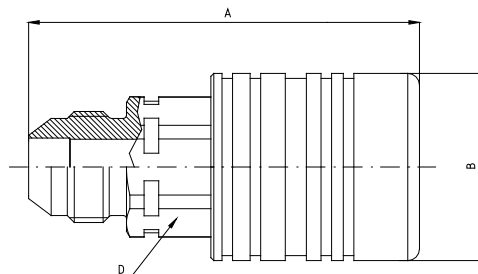

### Q01311250A

SAE TERMINATION ENDS  
TO ISO 8434-2

SIZE			PART NUMBER	THREAD	DIMENSIONS mm					
DN	inch	Size	Female coupling		A	B	D			
10	3/8"	-06	Q01311250A-06-08	3/4"-16 UNF	66.7	ø32	22			

SAE

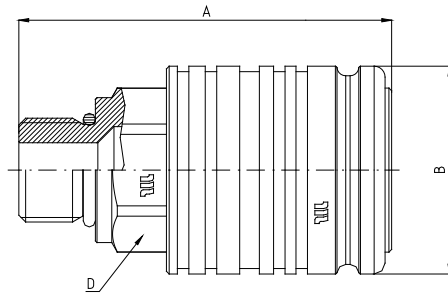

### Q01311320A

ORB TERMINATION ENDS

TO SAE J1926-2

S SERIES

SIZE			PART NUMBER	THREAD	DIMENSIONS mm					
DN	inch	Size	Female coupling		A	B	D			
12.5	1/2"	-08	Q01311320A-08-08	3/4"-16 UNF	68.2	ø38	27			

ORFS

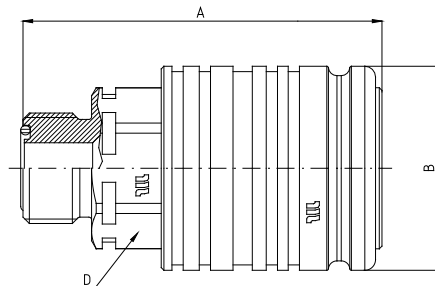

### Q01311240A

ORFS TERMINATION ENDS

TO ISO 8434-3

SIZE			PART NUMBER	THREAD	DIMENSIONS mm					
DN	inch	Size	Female coupling		A	B	D			
10	3/8"	-06	Q01311240A-06-04	9/16"-18 UN	60.8	ø32	22			
			Q01311240A-06-06	11/16"-16 UN	61.2	ø32	22			
12.5	1/2"	-08	Q01311240A-08-08	13/16"-16 UN	66.2	ø38	27			
25	1"	-16	Q01311240A-16-16	1.7/16"-12 UN	100	ø54	41			



## PUSH-PULL CONNECTABLE UNDER PRESSURE - TERMINATION ENDS

<b>SIZE</b>	<b>WORKING PRESSURE (Dynamic)</b>	<b>RATED FLOW at 0.2 MPa of pressure drop</b>	<b>CONNECTION EFFORT</b>	<b>OIL SPILLAGE Connection/ Disconnection</b>	<b>MINIMUM BURST PRESSURE</b>	<b>CONNECTION/ DISCONNECTION UNDER PRESSURE</b>

mm	inch	dash	MPa	PSI	l/min	US GPM	N	lb.	cc.	cubic inch	Female		M & F		
											MPa	PSI	MPa	PSI	
12.5	½	08	30	4350	68	18.0	110	244	2	0.122	120	17400	140	20300	Connection only
With 0 MPa pressure											120	17400	140	20300	Connection only

Pressure Drop

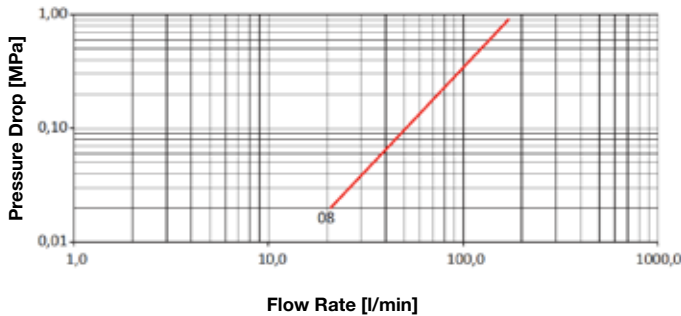

Pressure Drop

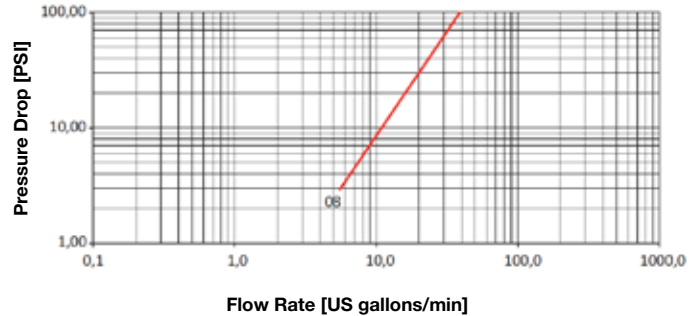

### Product description:

- Female coupling designed for agriculture applications, connectable with ISO 7241-1 series A male couplings
- Connectable under pressure thanks to a frontal micro-valve
- Push-Pull connection and disconnection system, in case of bulkhead mounting on the external sleeve
- Break-away function according to ISO 5675 (in case of bulkhead mounting on the external sleeve)
- Positive connection by latching balls system
- Shut-off by poppet valve
- High resistant materials
- Dimensions and performances according to ISO 7241-1 series A

<b>Material</b>	Female couplings in steel with some hardened areas, in correspondence to the most stressed points. Carbonitrided valve, micro-valve and sleeve, springs in C98 steel, latching balls in 100 C6 steel, seals in NBR and polyurethane (other materials on request) and back-up ring in PTFE
<b>Working Temperature</b>	-22°F up to +230°F (-30°C up to +110°C) For other temperatures, the quick coupling is assembled with specific seals
<b>Safety Factor</b>	4:1 for dynamic pressures
<b>Impulse Pressures</b>	100,000 cycles of impulse pressure at 133% of the rated one (freq. 1Hz)
<b>Test Specifications</b>	ISO 7241-2



## PUSH-PULL CONNECTABLE UNDER PRESSURE - TERMINATION ENDS

BSP

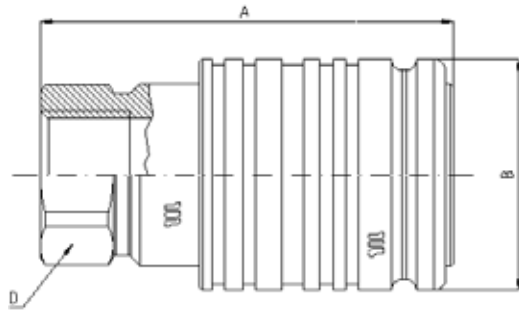

### Q01511041A

BSP TERMINATION ENDS  
TO DIN 3852 X TYPE

SIZE			PART NUMBER	THREAD	DIMENSIONS mm					
DN	inch	Size	Female coupling		A	B	D			
12.5	1/2"	-08	Q01511041A-08-08	1/2"	67	ø38	27			

METRIC

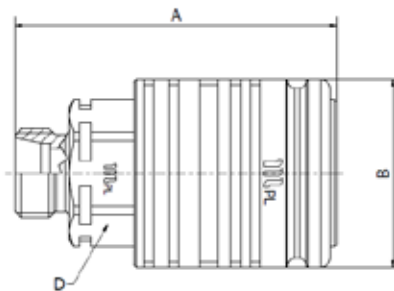

### Q0151110A

METRIC TERMINATION END  
TO ISO 8434-1  
L SERIES

SIZE			PART NUMBER	THREAD	DIMENSIONS mm					
DN	inch	Size	Female coupling		A	B	D			
12.5	1/2"	-08	Q0151110A-08-18	M18x1,5	65.2	ø38	27			

NPT

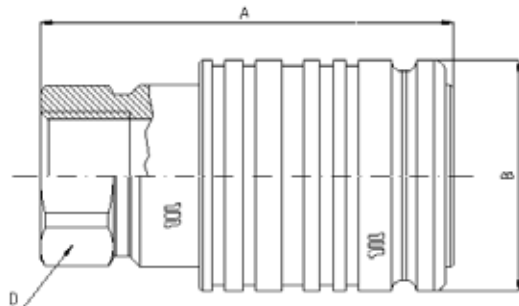

### Q01511341A

NPT TERMINATION END  
TO ANSI B 1.20.3 STANDARD

SIZE			PART NUMBER	THREAD	DIMENSIONS mm					
DN	inch	Size	Female coupling		A	B	D			
12.5	1/2"	-08	Q01511341A-08-08	1/2" NPTF	67	ø38	27			





## PUSH-PULL FEMALE CONNECTABLE WITH MALE UNDER PRESSURE

<b>SIZE</b>	<b>WORKING PRESSURE (Dynamic)</b>	<b>RATED FLOW at 0.2 MPa of pressure drop</b>	<b>CONNECTION EFFORT</b>	<b>OIL SPILLAGE Connection/ Disconnection</b>	<b>MINIMUM BURST PRESSURE</b>	<b>CONNECTION/ DISCONNECTION UNDER PRESSURE</b>

mm	inch	dash	MPa	PSI	l/min	US GPM	N	lb.	cc.	cubic inch	Female		M & F		Connection only, with male under pressure
											MPa	PSI	MPa	PSI	
12.5	½	08	30	4350	71	18.8	170	378	2	0.122	125	18125	125	18125	

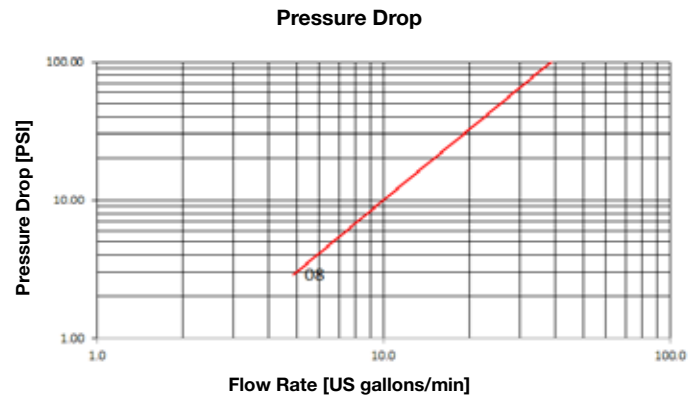
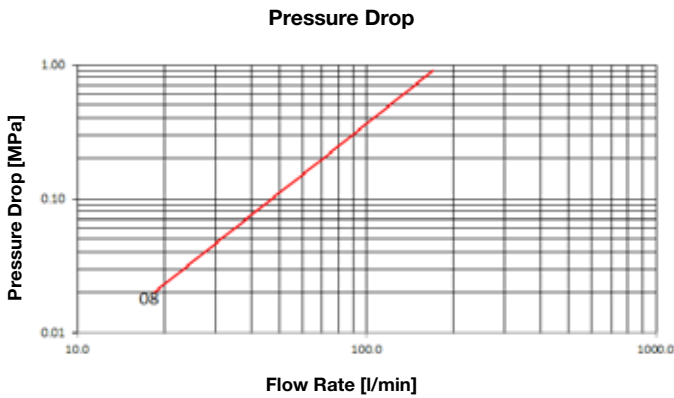

### Product description:

- Connectable with male ISO A under pressure
- Working pressure 30MPa
- Connection/disconnection PUSH-PULL
- No shut-off, Manuli mechanical valve block system
- Installation on hoses with coupling blocked on panel by the sleeve
- Breakaway function according to ISO 5675
- Interchangeable according to ISO 7241-1 part A
- Wide range of termination end

<b>Material</b>	Couplings in steel with some stressed area hardened, carbonitrided valve, springs in C98 steel, seals in NBR, back-up ring PTFE
<b>Working Temperature</b>	-22°F up to +230°F (-30°C up to +110°C) For other temperatures, the quick coupling is assembled with specific seals
<b>Safety Factor</b>	4:1 for dynamic pressures
<b>Impulse Pressures</b>	500,000 cycles (connected and disconnected conditions) at 120% of the rated one (freq. 1Hz)
<b>Test Specifications</b>	ISO 7241-2





BSP

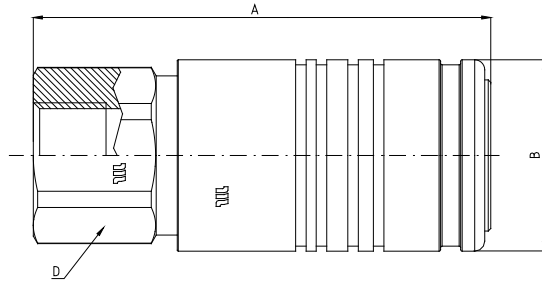

## Q01611041A

BSP TERMINATION ENDS  
TO DIN 3852 X TYPE

SIZE			PART NUMBER	THREAD	DIMENSIONS mm					
DN	inch	Size	Female coupling		A	B	D			
12.5	1/2"	-08	Q01611041A-08-08	1/2"	91.2	ø38	32			

SAE

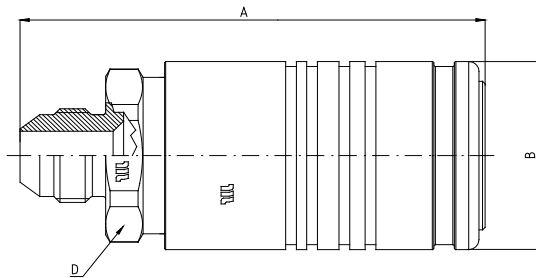

## Q01611250A

SAE TERMINATION ENDS  
TO ISO 8434-2

SIZE			PART NUMBER	THREAD	DIMENSIONS mm					
DN	inch	Size	Female coupling		A	B	D			
12.5	1/2"	-08	Q01611250A-08-08	3/4"- 16 UNF	90.7	ø38	32			





## PUSH-PULL FEMALE BOTH PARTS CONNECTABLE UNDER PRESSURE

	<b>MPa</b>		<b>N</b>			
<b>SIZE</b>	<b>WORKING PRESSURE (Dynamic)</b>	<b>RATED FLOW at 0.2 MPa of pressure drop</b>	<b>CONNECTION EFFORT</b>	<b>OIL SPILLAGE Connection/ Disconnection</b>	<b>MINIMUM BURST PRESSURE</b>	<b>CONNECTION/ DISCONNECTION UNDER PRESSURE</b>

mm	inch	dash	MPa	PSI	l/min	US GPM	N	lb.	cc.	cubic inch	Female		M & F		Connection only, with male and female under pressure
											MPa	PSI	MPa	PSI	
12.5	½	08	30	4350	71	18.8	170	378	2	0.122	125	18125	125	18125	
											With 0 MPa of pressure				

Pressure Drop

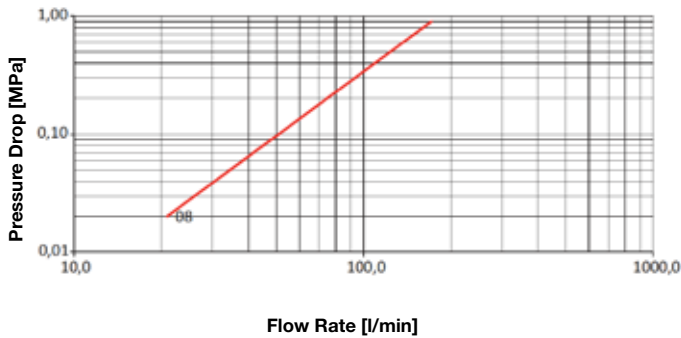

Pressure Drop

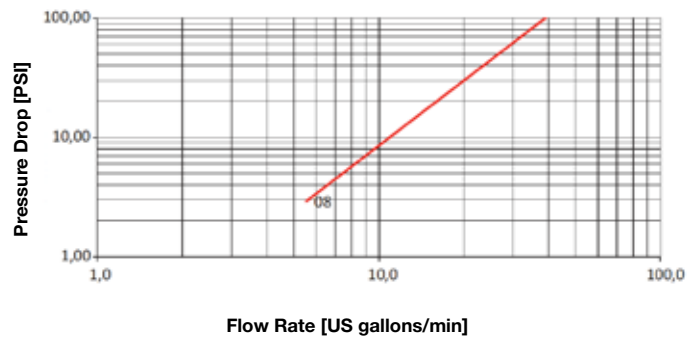

### Product description:

- Connectable with male ISO A and female under pressure
- Working pressure 30MPa
- Connection/disconnection PUSH-PULL
- No shut-off, Manuli mechanical valve block system
- Installation on hoses with coupling blocked on panel by the sleeve
- Breakaway function according to ISO 5675
- Interchangeable according to ISO 7241-1 part A
- Wide range of termination ends

<b>Material</b>	Couplings in steel with some stressed area hardened, carbonitrided valve, springs in C98 steel, seals in polyurethane and NBR, back-up ring PTFE
<b>Working Temperature</b>	-22°F up to +230°F (-30°C up to +110°C) For other temperatures, the quick coupling is assembled with specific seals
<b>Safety Factor</b>	4:1 for dynamic pressures
<b>Impulse Pressures</b>	500,000 cycles (connected and disconnected conditions) at 120% of the rated one (freq. 1Hz)
<b>Test Specifications</b>	ISO 7241-2



PUSH-PULL FEMALE BOTH PARTS CONNECTABLE UNDER PRESSURE - TERMINATION ENDS

BSP

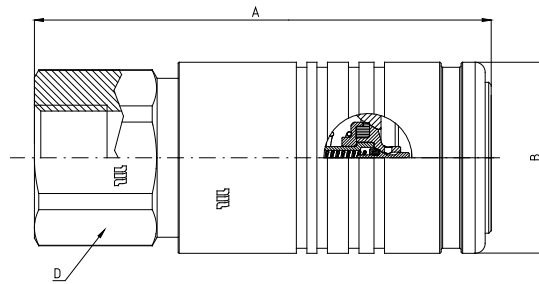

## Q01711041A

BSP TERMINATION ENDS  
TO DIN 3852 X TYPE

SIZE			PART NUMBER	THREAD	DIMENSIONS mm					
DN	inch	Size	Female coupling		A	B	D			
12.5	1/2"	-08	Q01711041A-08-08		1/2"	91.2	ø38			

SAE

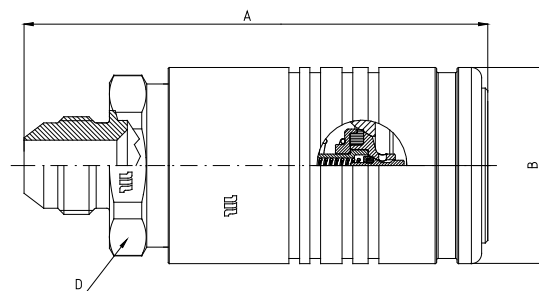

## Q01711250A

SAE TERMINATION ENDS  
TO ISO 8434-2

SIZE			PART NUMBER	THREAD	DIMENSIONS mm					
DN	inch	Size	Female coupling		A	B	D			
12.5	1/2"	-08	Q01711250A-08-08	3/4"- 16 UNF	90.7	ø38	32			





## PUSH-PULL FEMALE CONNECTABLE WITH MALE UNDER PRESSURE

<b>SIZE</b>	<b>WORKING PRESSURE (Dynamic)</b>	<b>RATED FLOW at 0.2 MPa of pressure drop</b>	<b>CONNECTION EFFORT</b>	<b>OIL SPILLAGE Connection/ Disconnection</b>	<b>MINIMUM BURST PRESSURE</b>	<b>CONNECTION/ DISCONNECTION UNDER PRESSURE</b>

mm	inch	dash	MPa	PSI	Flow direction	l/min	US GPM	N	lb.	cc.	cubic inch	Female		M & F		
												MPa	PSI	MPa	PSI	
12.5	½	08	30	4350	F → M	80	21.1	230	511	2.1	0.128	125	18125	125	18125	Connection only, with male under pressure
					M → F	68	18.0									

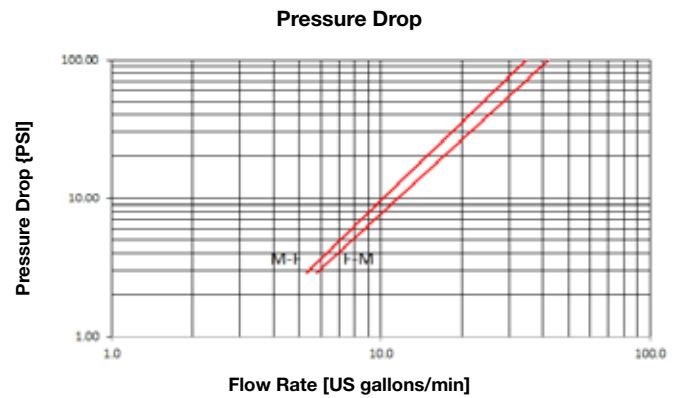
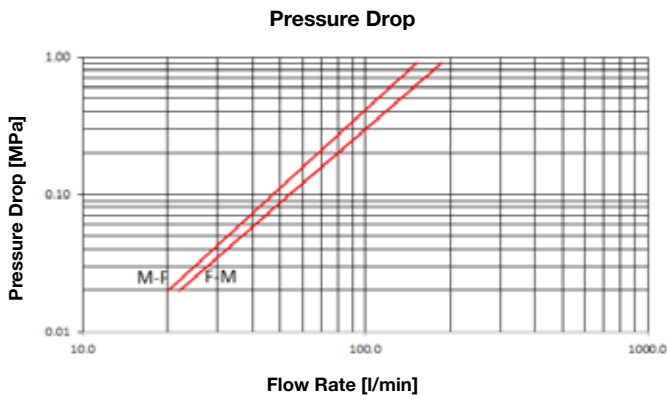

### Product description:

- Connectable with male ISO A under pressure
- Working pressure 30MPa
- Connection/disconnection PUSH-PULL
- No shut-off, Manuli mechanical valve block system
- Installation on pipe and ports
- Breakaway function according to ISO 5675
- Interchangeable according to ISO 7241-1 part A
- Wide range of termination ends
- According to all requirements of ISO 5675

<b>Material</b>	Couplings in steel with some stressed area hardened, carbonitrided valve, springs in C98 steel, seals in NBR, back-up ring PTFE
<b>Working Temperature</b>	-22°F up to +230°F (-30°C up to +110°C) For other temperatures, the quick coupling is assembled with specific seals
<b>Safety Factor</b>	4:1 for dynamic pressures
<b>Impulse Pressures</b>	500,000 cycles (connected and disconnected conditions) at 120% of the rated one (freq. 1Hz)
<b>Test Specifications</b>	ISO 7241-2





## PUSH-PULL MALE CONNECTABLE UNDER PRESSURE - TERMINATION ENDS

BSP

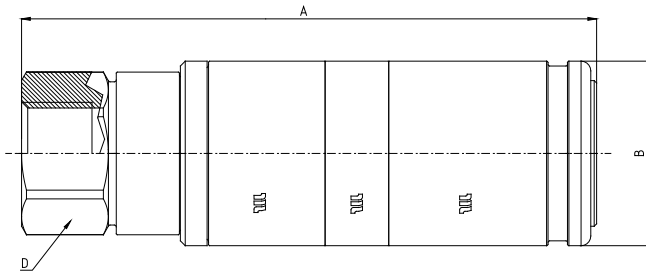

### Q01811041A

BSP TERMINATION ENDS  
TO DIN 3852 X TYPE

SIZE			PART NUMBER	THREAD	DIMENSIONS mm					
DN	inch	Size	Female coupling		A	B	D			
12.5	1/2"	-08	Q01811041A-08-08	1/2"	118.4	ø38	30			

METRIC

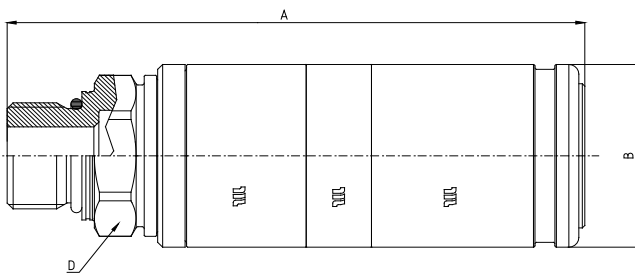

### Q01811190A

METRIC TERMINATION ENDS  
TO ISO 6149-2

SIZE			PART NUMBER	THREAD	DIMENSIONS mm					
DN	inch	Size	Female coupling		A	B	D			
12.5	1/2"	-08	Q01811190A-08-22	M22x1,5	115.9	ø38	30			

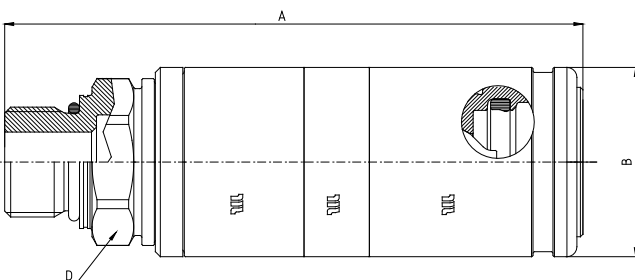

### Q01811190U

POLYURETHANE SEAL  
METRIC TERMINATION ENDS  
TO ISO 6149-2

SIZE			PART NUMBER	THREAD	DIMENSIONS mm					
DN	inch	Size	Female coupling		A	B	D			
12.5	1/2"	-08	Q01811190U-08-22	M22x1,5	115.9	ø38	30			

Polyurethane seal

METRIC

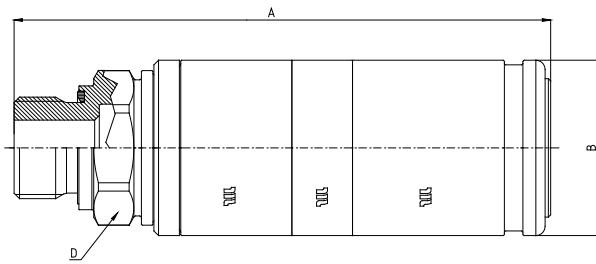

## Q0181140A

METRIC TERMINATION ENDS

TO ISO 9974-2

SIZE			PART NUMBER	THREAD	DIMENSIONS mm					
DN	inch	Size	Female coupling		A	B	D			
12.5	1/2"	-08	Q0181140A-08-22	M22x1,5	115.9	ø38	30			

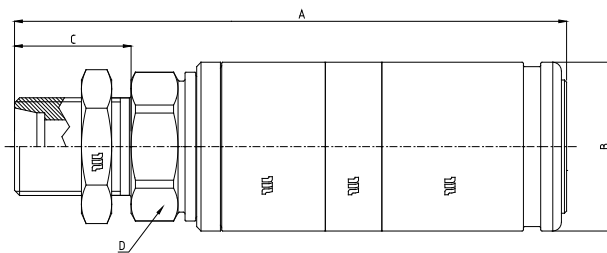

## Q01811770B

METRIC TERMINATION ENDS

ISO 8434-1 L SERIES  
BULKHEAD

SIZE			PART NUMBER	THREAD	DIMENSIONS mm					
DN	inch	Size	Female coupling		A	B	C	D		
12.5	1/2"	-08	Q01811770B-08-22	M22x1,5	127.9	ø38	27	30		

NPT

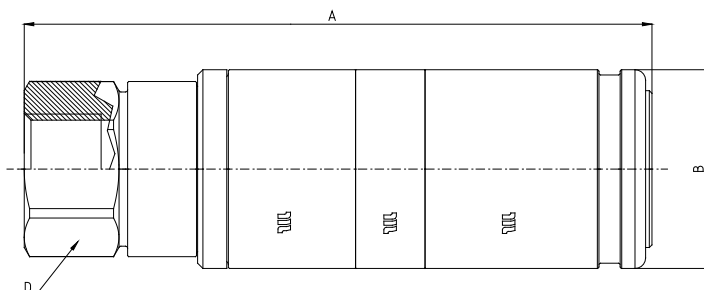

## Q01811341A

NPT TERMINATION ENDS

TO ANSI B 1.20.3

SIZE			PART NUMBER	THREAD	DIMENSIONS mm					
DN	inch	Size	Female coupling		A	B	D			
12.5	1/2"	-08	Q01811341A-08-08	1/2" NPTF	118.4	ø38	30			

SAE

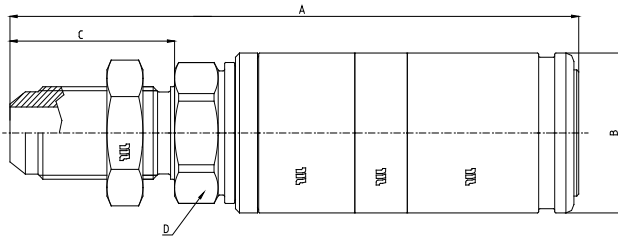

### Q01811230A

SAE TERMINATION ENDS  
ISO 8434-2 BULKHEAD

SIZE			PART NUMBER	THREAD	DIMENSIONS mm					
DN	inch	Size	Female coupling		A	B	C	D		
12.5	1/2"	-08	Q01811230A-08-08	3/4"-16 UNF	138.5	ø38	37.6	30		
			Q01811230A-08-10	7/8"-14UNF	142	ø38	40.1	30		

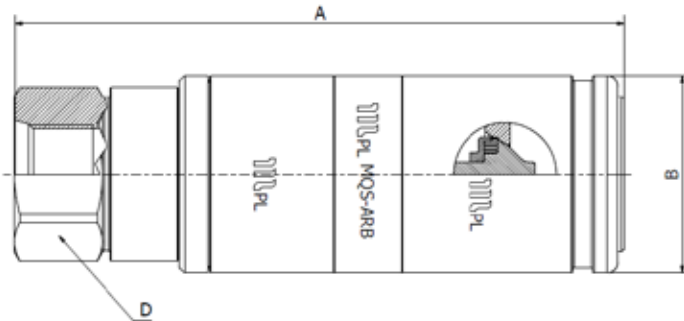

### Q01811301A

SAE TERMINATION ENDS  
TO SAE J1926-1

SIZE			PART NUMBER	THREAD	DIMENSIONS mm					
DN	inch	Size	Female coupling		A	B	D			
12.5	1/2"	-08	Q01811301A-08-08	3/4"-16 UNF	117.4	ø38	30			

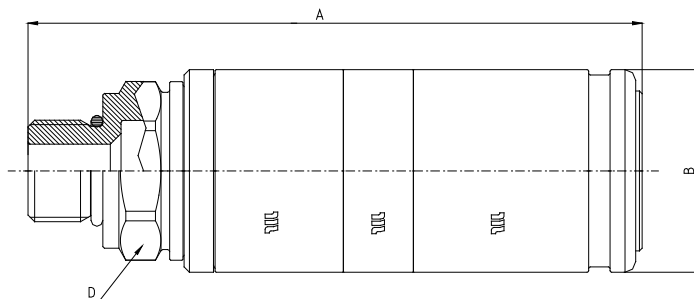

### Q01811320A

ORB TERMINATION ENDS  
TO SAE J1926-2 S SERIES

SIZE			PART NUMBER	THREAD	DIMENSIONS mm					
DN	inch	Size	Female coupling		A	B	D			
12.5	1/2"	-08	Q01811320A-08-08	3/4"-16 UNF	115	ø38	30			
			Q01811320A-08-10	7/8"-14UNF	117	ø38	30			





## PUSH-PULL FEMALE BOTH PARTS CONNECTABLE UNDER PRESSURE

<b>SIZE</b>	<b>WORKING PRESSURE (Dynamic)</b>	<b>RATED FLOW at 0.2 MPa of pressure drop</b>	<b>CONNECTION EFFORT</b>	<b>OIL SPILLAGE Connection/ Disconnection</b>	<b>MINIMUM BURST PRESSURE</b>	<b>CONNECTION/ DISCONNECTION UNDER PRESSURE</b>

mm	inch	dash	MPa	PSI	Flow direction	l/min	US GPM	N	lb.	cc.	cubic inch	Female		M & F		
												MPa	PSI	MPa	PSI	
12.5	½	08	30	4350	F → M	80	21.1	230	511	2.5	0.153	125	18125	125	18125	Connection only, with male and female under pressure
					M → M	68	18.0									

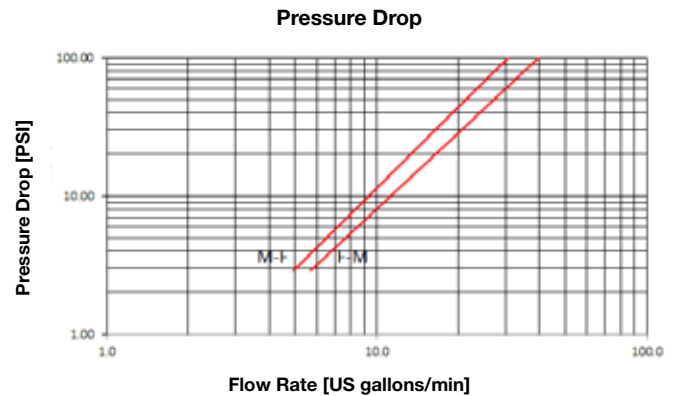
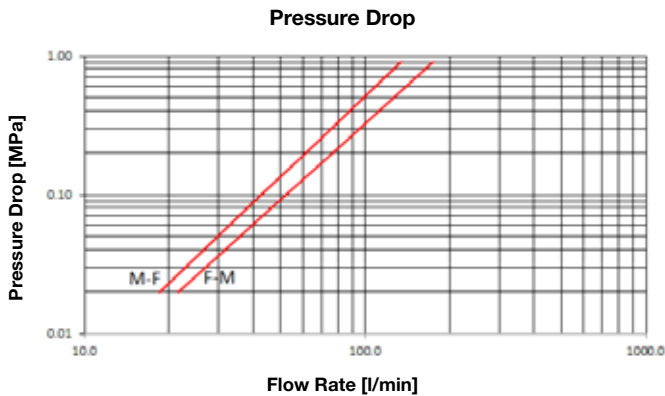

### Product description:

- Connectable with male ISO A and female under pressure
- Working pressure 30MPa
- Connection/disconnection PUSH-PULL
- No shut-off, Manuli mechanical valve block system
- Installation on pipe and ports
- Breakaway function according to ISO 5675
- Interchangeable according to ISO 7241-1 part A
- Wide range of termination ends
- According to all requirements of ISO 5675

<b>Material</b>	Couplings in steel with some stressed area hardened, carbonitrided valve, springs in C98 steel, seals in polyurethane and NBR, back-up ring PTFE
<b>Working Temperature</b>	-22°F up to +230°F (-30°C up to +110°C) For other temperatures, the quick coupling is assembled with specific seals
<b>Safety Factor</b>	4:1 for dynamic pressures
<b>Impulse Pressures</b>	500,000 cycles (connected and disconnected conditions) at 120% of the rated one (freq. 1Hz)
<b>Test Specifications</b>	ISO 7241-2



BSP

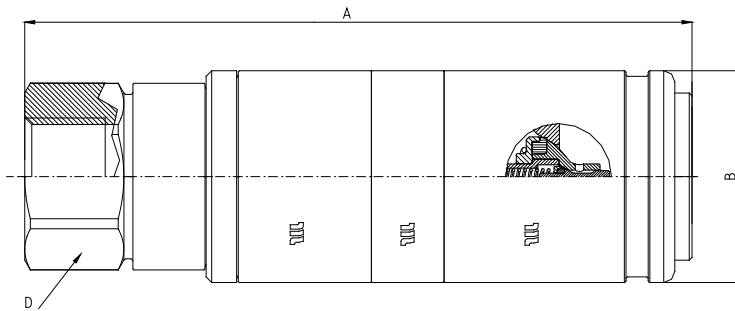

**Q01911041A**

BSP TERMINATION ENDS  
TO DIN 3852 X TYPE

SIZE			PART NUMBER	THREAD	DIMENSIONS mm					
DN	inch	Size	Female coupling		A	B	D			
12.5	1/2"	-08	Q01911041A-08-08	1/2"	120.3	ø38	30			

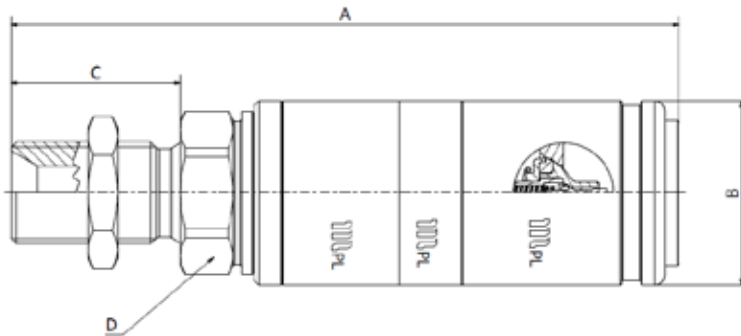

**Q01911040A**

BSP TERMINATION ENDS  
TO DIN 3852  
BULKHEAD

SIZE			PART NUMBER	THREAD	DIMENSIONS mm					
DN	inch	Size	Female coupling		A	B	C	D		
12.5	1/2"	-08	Q01911040A-08-08	1/2"	137.8	ø38	35	30		

METRIC

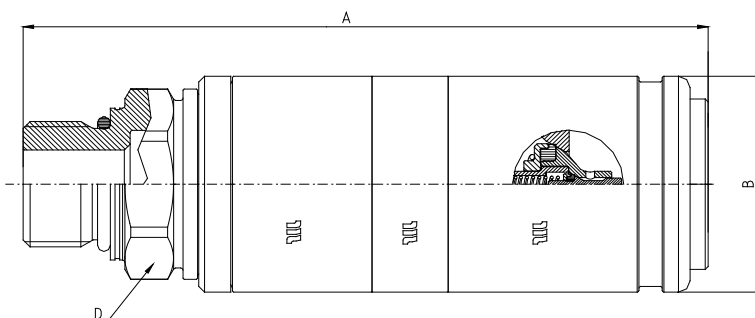

**Q01911190A**

METRIC TERMINATION ENDS  
TO ISO 6149-2

SIZE			PART NUMBER	THREAD	DIMENSIONS mm					
DN	inch	Size	Female coupling		A	B	D			
12.5	1/2"	-08	Q01911190A-08-22	M22x1,5	117.8	ø38	30			

METRIC

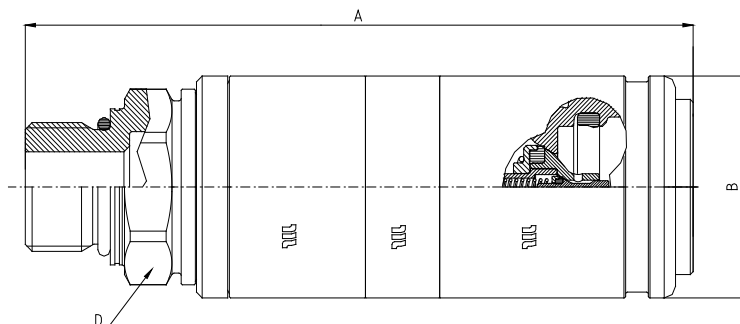

**Q0191190U**  
 POLYURETHANE SEAL  
 METRIC TERMINATION ENDS  
 TO ISO 6149-2

SIZE			PART NUMBER	THREAD	DIMENSIONS mm					
DN	inch	Size	Female coupling		A	B	D			
12.5	1/2"	-08	Q0191190U-08-22	M22x1,5	117.8	ø38	30			

Polyurethane seal

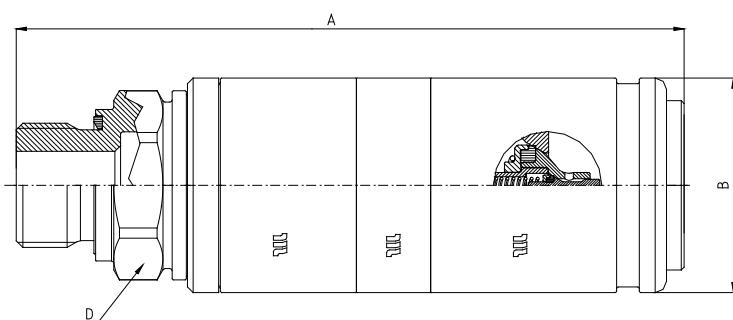

**Q0191140A**  
 METRIC TERMINATION ENDS  
 TO ISO 9974-2

SIZE			PART NUMBER	THREAD	DIMENSIONS mm					
DN	inch	Size	Female coupling		A	B	D			
12.5	1/2"	-08	Q0191140A-08-22	M22x1,5	117.8	ø38	30			

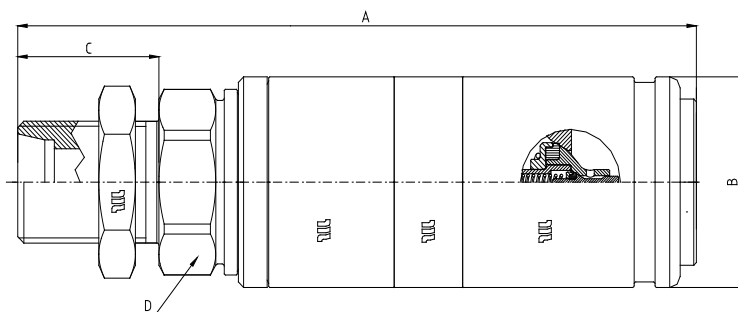

**Q01911770B**  
 METRIC TERMINATION ENDS  
 ISO 8434-1 L SERIES  
 BULKHEAD

SIZE			PART NUMBER	THREAD	DIMENSIONS mm					
DN	inch	Size	Female coupling		A	B	C	D		
12.5	1/2"	-08	Q01911770B-08-22	M22x1,5	129.8	ø38	27	30		



PUSH-PULL BOTH PARTS CONNECTABLE UNDER PRESSURE - TERMINATION ENDS

METRIC

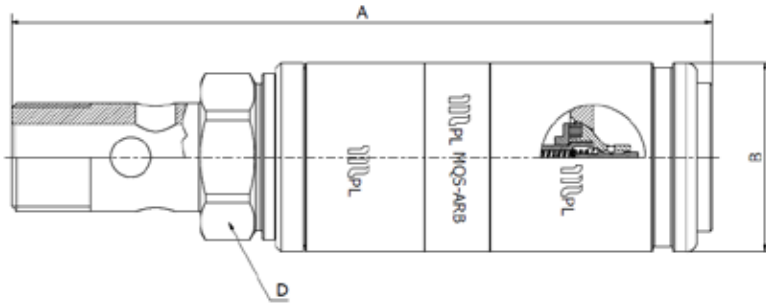

## Q01911080A

METRIC TERMINATION ENDS

DIN 7643

SIZE			PART NUMBER	THREAD	DIMENSIONS mm					
DN	inch	Size	Female coupling		A	B	D			
12.5	1/2"	-08	Q01911080A-08-22	M22x1,5	140.8	ø38	30			

NPTF

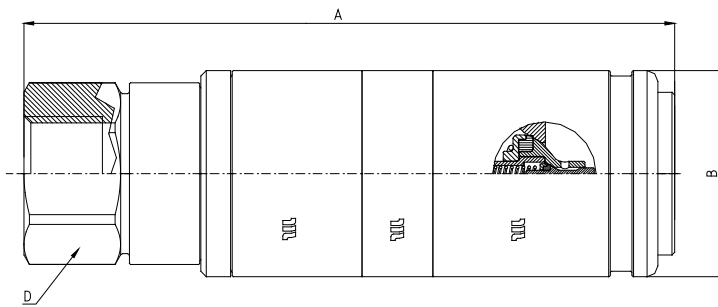

## Q01911341A

NPT TERMINATION ENDS

TO ANSI B 1.20.3

SIZE			PART NUMBER	THREAD	DIMENSIONS mm					
DN	inch	Size	Female coupling		A	B	D			
12.5	1/2"	-08	Q01911341A-08-08	1/2" NPTF	120.3	ø38	30			

SAE

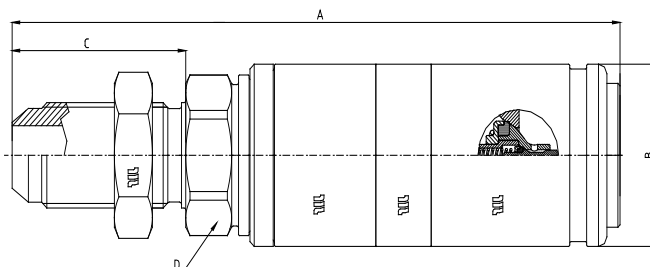

## Q01911230A

SAE TERMINATION ENDS

ISO 8434-2 BULKHEAD

SIZE			PART NUMBER	THREAD	DIMENSIONS mm					
DN	inch	Size	Female coupling		A	B	C	D		
12.5	1/2"	-08	Q01911230A-08-10	7/8"-14UNF	143.9	ø38	40.1	30		

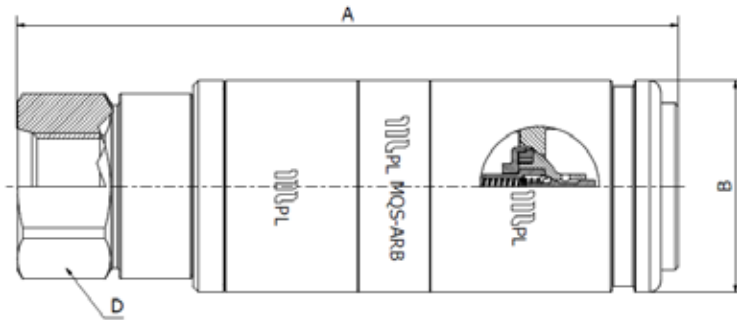

**Q01911301A**  
SAE TERMINATION ENDS  
TO SAE J1926-1

SIZE			PART NUMBER	THREAD	DIMENSIONS mm					
DN	inch	Size	Female coupling		A	B	D			
12.5	1/2"	-08	Q01911301A-08-08	3/4"-16 UNF	119.3	ø38	30			

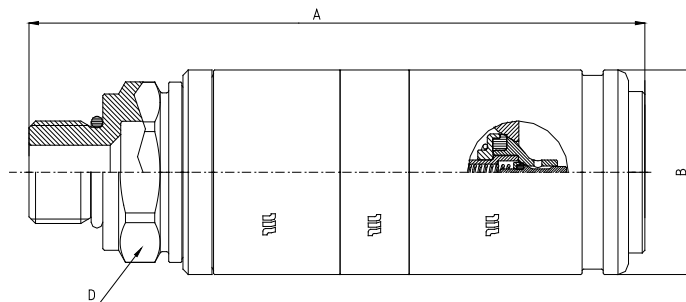

**Q01911320A**  
ORB TERMINATION ENDS  
TO SAE J1926-2 S SERIES

SIZE			PART NUMBER	THREAD	DIMENSIONS mm					
DN	inch	Size	Female coupling		A	B	D			
12.5	1/2"	-08	Q01911320A-08-08	3/4"-16 UNF	116.9	ø38	30			
			Q01911320A-08-10	7/8"-14UNF	118.9	ø38	30			

## BRAKING CIRCUIT VALVES



<b>SIZE</b>	<b>WORKING PRESSURE (Dynamic)</b>	<b>RATED FLOW at 0.2 MPa of pressure drop</b>	<b>CONNECTION EFFORT</b>	<b>OIL SPILLAGE Connection/ Disconnection</b>	<b>MINIMUM BURST PRESSURE</b>	<b>CONNECTION/ DISCONNECTION UNDER PRESSURE</b>

mm	inch	dash	MPa	PSI	l/min	US GPM	N	lb.	cc.	cubic inch	Male		Female		M & F		Not allowed
											MPa	PSI	MPa	PSI	MPa	PSI	
12.5	1/2	08	15	2175	31	8.2	110	224	0.02	0.001	130	18850	60	8700	130	18850	Not allowed

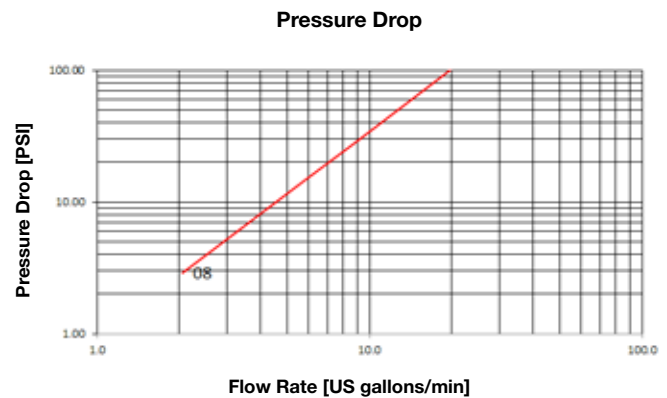
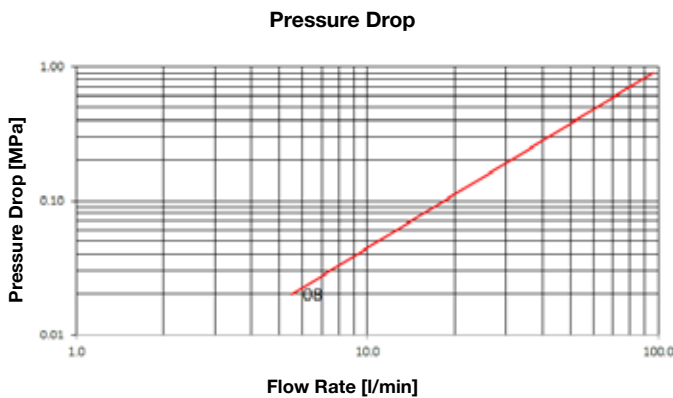

### Product description:

- Trailer brake coupling specially designed to connect the hydraulic braking system of tractors to trailers
- Connection and disconnection by pulling back the sleeve
- Positive connection by latching balls system
- Shut-off by flat valve
- The male has to be placed on the tractor and the female on the implement
- Interchangeable according to ISO 5676

<b>Material</b>	Female and male coupling in steel, with some stressed tempered areas. Carbonitrided valve and sleeve, springs in C98 steel, seals in NBR and back-up ring PTFE
<b>Working Temperature</b>	-22°F up to +230°F (-30°C up to +110°C)
<b>Safety Factor</b>	4:1 for dynamic pressures
<b>Test Specifications</b>	ISO 5676 and ISO 7241-2



Safety cap for male coupling and female coupling with parking included



## BRAKING CIRCUIT VALVES - TERMINATION ENDS

BSP

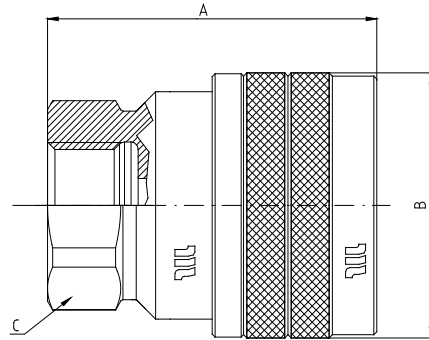

### Q04811041A

BSP TERMINATION ENDS  
TO DIN 3852 X TYPE

SIZE			PART NUMBER		THREAD	DIMENSIONS mm				
DN	inch	Size	Female coupling			A	B	C		
12.5	1/2"	-08	Q04811041A-08-06		3/8"	55,5	ø44	32		
			Q04811041A-08-08		1/2"	56,5	ø44	32		

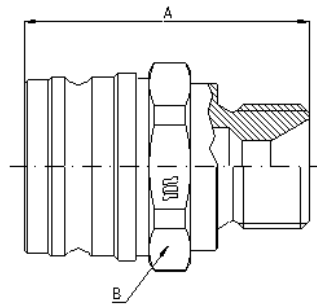

### Q04711050A

BSP TERMINATION ENDS  
TO ISO 8434-6

SIZE			PART NUMBER		THREAD	DIMENSIONS mm				
DN	inch	Size	Male coupling			A	B			
12.5	1/2"	-8	Q04711050A-08-08		1/2"	48	32			

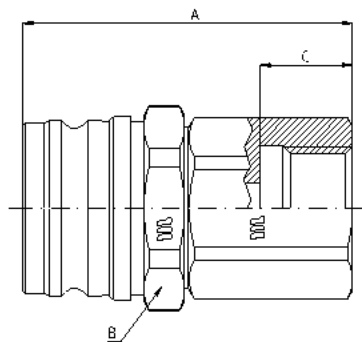

### Q04711041A

BSP TERMINATION ENDS  
TO DIN 3852 X TYPE

SIZE			PART NUMBER		THREAD	DIMENSIONS mm				
DN	inch	Size	Male coupling			A	B	C		
12.5	1/2"	-08	Q04711041A-08-08		1/2" GAS	57	32	16		

BSP

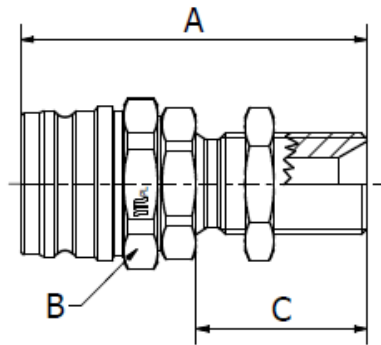

### Q04711040A

BSP TERMINATION ENDS  
TO DIN3852  
BULKHEAD

SIZE			PART NUMBER	THREAD	DIMENSIONS mm				
DN	inch	Size	Male coupling		A	B	C		
12.5	1/2"	-08	Q04711040A-08-08	1/2"	70.8	32	35		

METRIC

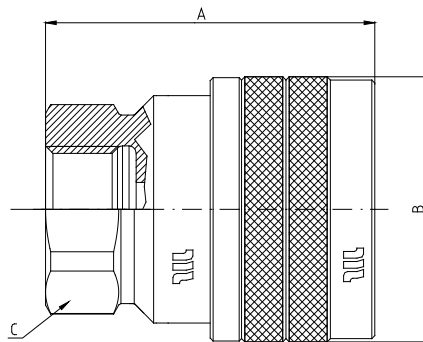

### Q04811141A

METRIC TERMINATION ENDS  
TO DIN 3852 X TYPE

SIZE			PART NUMBER	THREAD	DIMENSIONS mm				
DN	inch	Size	Female coupling		A	B	C		
12.5	1/2"	-08	Q04811141A-08-18	M18x1,5	55,5	ø44	32		

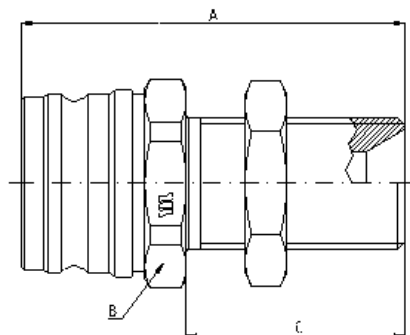

### Q04711370A

METRIC TERMINATION ENDS  
TO DIN 3863  
BULKHEAD

SIZE			PART NUMBER	THREAD	DIMENSIONS mm				
DN	inch	Size	Male coupling		A	B			
12.5	1/2"	-08	Q04711370A-08-22	M22x1,5	65	32	37		

METRIC

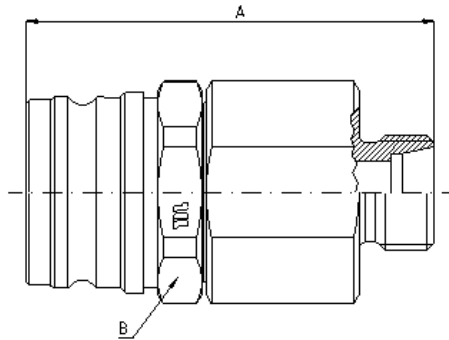

### Q0471110A

METRIC TERMINATION ENDS

TO ISO 8434-1

L SERIES

SIZE			PART NUMBER	THREAD	DIMENSIONS mm				
DN	inch	Size	Male coupling		A	B			
12.5	1/2"	-08	Q04711110A-08-18	M18x1,5	65	32			
			Q04711110A-08-22	M22x1,5	64.7	32			

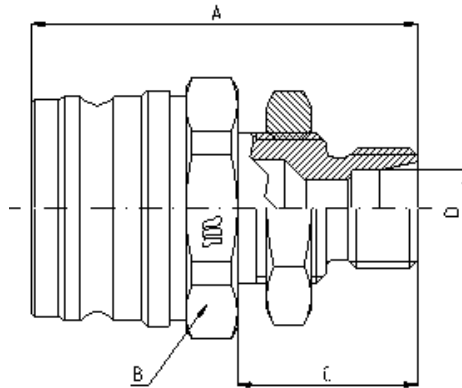

### Q04711770A

METRIC TERMINATION END

TO ISO 8434-1

BULKHEAD

SIZE			PART NUMBER	THREAD	DIMENSIONS mm				
DN	inch	Size	Male coupling		A	B	C	D	
12.5	1/2"	-08	Q04711770A-08-16	M16x1,5	52.5	32	24.5	ø10,2	
			Q04711770A-08-18	M18x1,5	52	32	24	ø12,2	

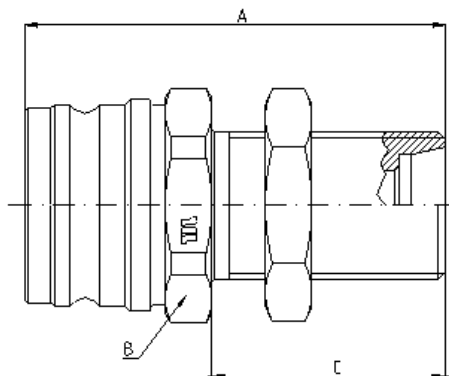

### Q04711770A

METRIC TERMINATION END

TO ISO 8434-1

BULKHEAD L SERIES

SIZE			PART NUMBER	THREAD	DIMENSIONS mm				
DN	inch	Size	Male coupling		A	B	C		
12.5	1/2"	-08	Q04711770A-08-22	M22x1,5	63	32	35		

METRIC

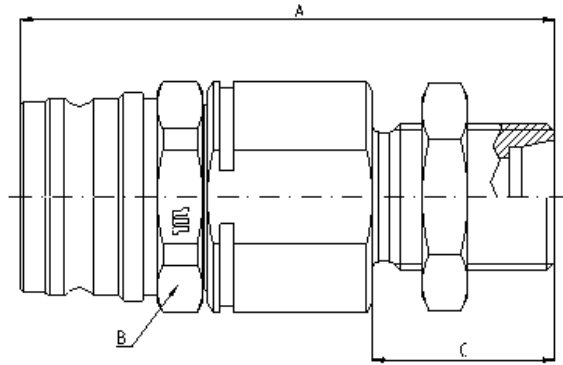

### Q04711770B

METRIC TERMINATION END

TO ISO 8434-1

BULKHEAD L SERIES

SIZE			PART NUMBER	THREAD	DIMENSIONS mm				
DN	inch	Size	Male coupling		A	B	C		
12.5	1/2"	-08	Q04711770B-08-22	M22x1,5	82	32	28		

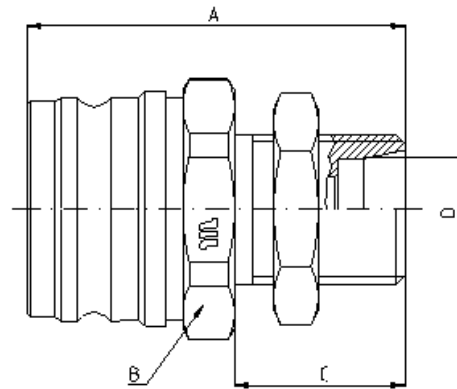

### Q04711820A

METRIC TERMINATION END

BULKHEAD

SIZE			PART NUMBER	THREAD	DIMENSIONS mm				
DN	inch	Size	Male coupling		A	B	C	D	
12.5	1/2"	-08	Q04711820A-08-20	M20x1,5	51	32	23	ø13,5	



SAE

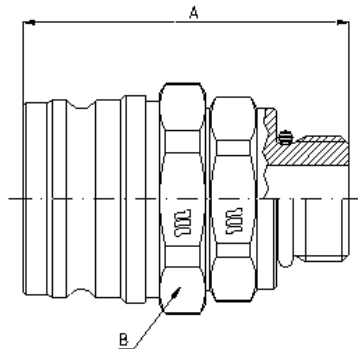

### Q04711300A

SAE TERMINATION END  
TO SAE J1926-3

SIZE			PART NUMBER	THREAD	DIMENSIONS mm				
DN	inch	Size	Male coupling		A	B			
12.5	1/2"	-08	Q04711300A-08-08	3/4"-16 UNF	50	32			

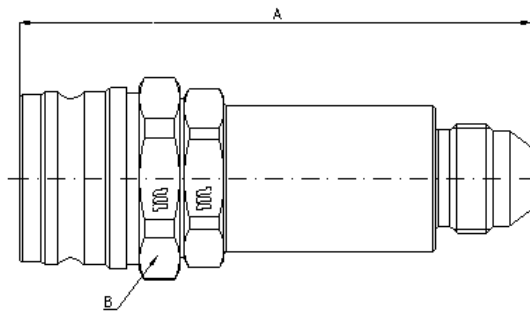

### Q04711250A

SAE TERMINATION ENDS  
TO ISO 8434-2

SIZE			PART NUMBER	THREAD	DIMENSIONS mm				
DN	inch	Size	Male coupling		A	B			
12.5	1/2"	-08	Q04711250A-08-08	3/4"-16 UNF	89.5	32			

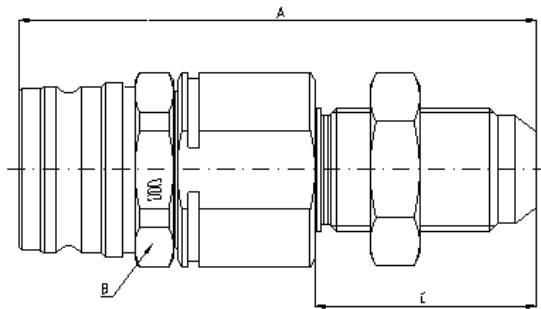

### Q04711230A

SAE TERMINATION ENDS  
TO ISO 8434-2  
BULKHEAD

SIZE			PART NUMBER	THREAD	DIMENSIONS mm				
DN	inch	Size	Male coupling		A	B	C		
12.5	1/2"	-08	Q04711230A-08-10	7/8"-14 UNF	94.8	32	40.1		





<b>SIZE</b>	<b>WORKING PRESSURE (Dynamic)</b>	<b>RATED FLOW at 0.2 MPa of pressure drop</b>	<b>OIL SPILLAGE Connection/ Disconnection</b>	<b>MINIMUM BURST PRESSURE</b>	<b>CONNECTION/ DISCONNECTION UNDER PRESSURE</b>

mm	inch	dash	MPa	PSI	l/min	US GPM	cc.	cubic inch	Male		Female		M & F		Allowed
									MPa	PSI	MPa	PSI	MPa	PSI	
12.5	1/2	08	20	2900	34	9.0	0.02	0.001	130	18850	80	11600	140	20300	Allowed

Pressure Drop

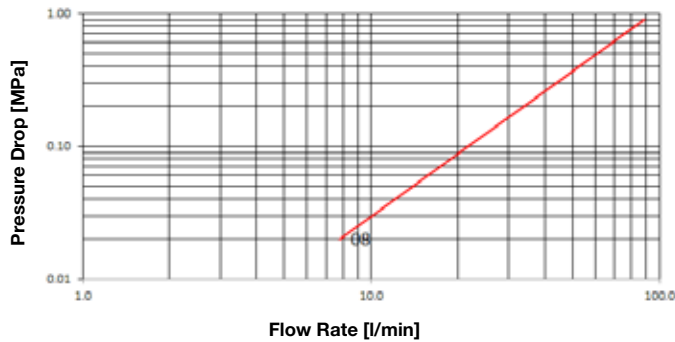

Pressure Drop

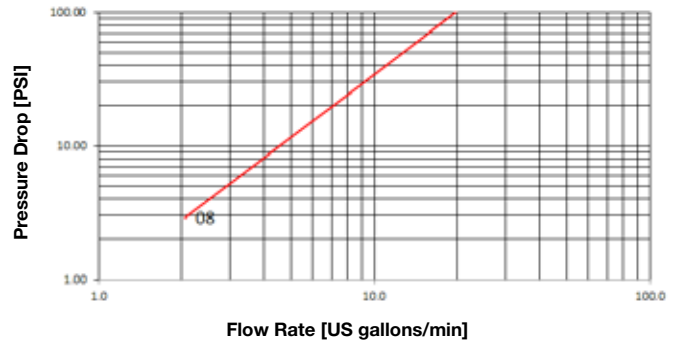

### Product description:

- Trailer brake coupling specially designed to connect the hydraulic breaking system of tractors to trailers
- Connection and disconnection by screwing the sleeve
- Connection secured on the thread between the sleeve and the male coupling
- Flat-valve
- Connection and disconnection under pressure allowed
- The male has to be placed on the tractor and the female on the implement
- Interchangeable with similar products available on the market

<b>Material</b>	Female and male coupling in steel, with hardened stressed areas. Carbonitrided valve, springs in C98 steel, seals in NBR and back-up ring PTFE
<b>Working Temperature</b>	-22°F up to +230°F (-30°C up to +110°C)
<b>Safety Factor</b>	4:1 for dynamic pressures
<b>Test Specifications</b>	ISO 5676 and ISO 7241-2



Safety cap for male coupling and female coupling with parking included



BSP

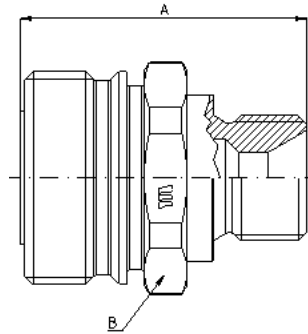

### Q04911050A

BSP TERMINATION ENDS

TO ISO 8434-6

SIZE			PART NUMBER	THREAD	DIMENSIONS mm				
DN	inch	Size	Male coupling		A	B			
12.5	1/2"	-08	Q04911050A-08-08	1/2" GAS	48	36			

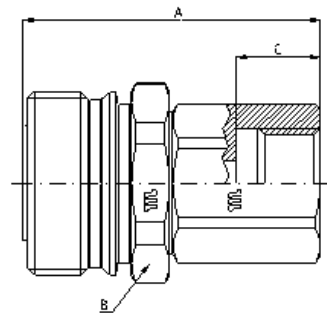

### Q04911041A

BSP TERMINATION ENDS

TO DIN 3852 X TYPE

SIZE			PART NUMBER	THREAD	DIMENSIONS mm				
DN	inch	Size	Male coupling		A	B	C		
12.5	1/2"	-08	Q04911041A-08-08	1/2" BSP	57	36	16		

METRIC

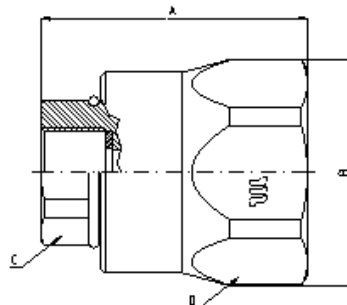

### Q05011141A

METRIC TERMINATION ENDS

TO DIN 3852 X TYPE

SIZE			PART NUMBER	THREAD	DIMENSIONS mm				
DN	inch	Size	Female coupling		A	B	C	D	
12.5	1/2"	-08	Q05011141A-08-18	M18x1,5	53.5	ø45	27	41	

METRIC

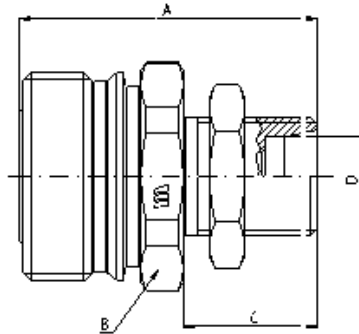

### Q04911820A

METRIC TERMINATION ENDS

BULKHEAD

SIZE			PART NUMBER	THREAD	DIMENSIONS mm				
DN	inch	Size	Male coupling		A	B	C	D	
12.5	1/2"	-08	Q04911820A-08-20	M20x1,5	51	36	23	ø13,5	

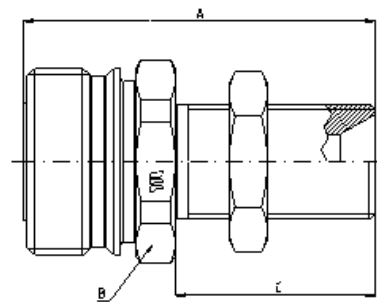

### Q04911370A

METRIC TERMINATION ENDS

TO DIN 3863

BULKHEAD

SIZE			PART NUMBER	THREAD	DIMENSIONS mm				
DN	inch	Size	Male coupling		A	B	C		
12.5	1/2"	-08	Q04911370A-08-22	M22x1,5	65	36	37		

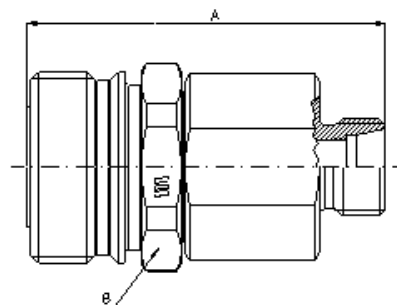

### Q04911110A

METRIC TERMINATION ENDS

TO ISO 8434-1

L SERIES

SIZE			PART NUMBER	THREAD	DIMENSIONS mm				
DN	inch	Size	Male coupling		A	B			
12.5	1/2"	-08	Q04911110A-08-18	M18x1,5	65	36			
			Q04911110A-08-22	M22x1,5	64.7	36			

METRIC

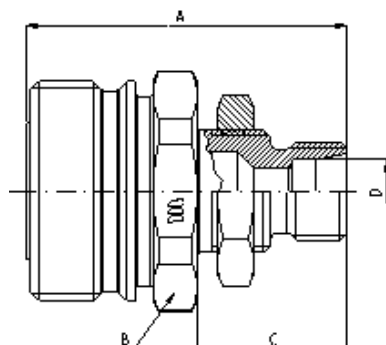

### Q04911770A

METRIC TERMINATION END  
TO ISO 8434-1  
BULKHEAD

SIZE			PART NUMBER	THREAD	DIMENSIONS mm				
DN	inch	Size	Male coupling		A	B	C	D	
12.5	1/2"	-08	Q04911770A-08-16	M16x1,5	52.5	36	24.5	ø10,2	
			Q04911770A-08-18	M18x1,5	52	36	24	ø12,2	

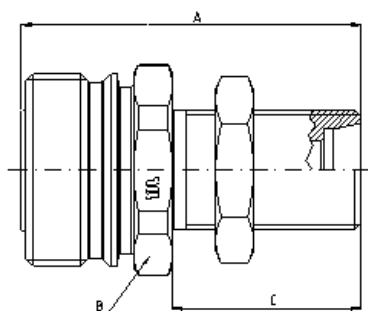

### Q04911770A

METRIC TERMINATION END  
TO ISO 8434-1  
BULKHEAD L SERIES

SIZE			PART NUMBER	THREAD	DIMENSIONS mm				
DN	inch	Size	Male coupling		A	B	C		
12.5	1/2"	-08	Q04911770A-08-22	M22x1,5	63	36	35		

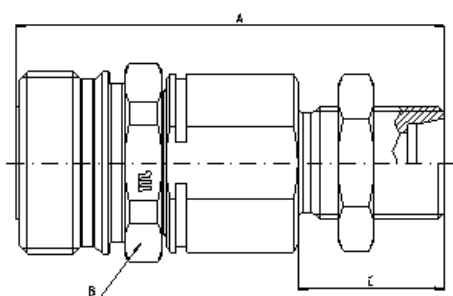

### Q04911770B

METRIC TERMINATION END  
TO ISO 8434-1  
BULKHEAD L SERIES

SIZE			PART NUMBER	THREAD	DIMENSIONS mm				
DN	inch	Size	Male coupling		A	B	C		
12.5	1/2"	-08	Q04911770B-08-22	M22x1,5	82	36	28		

### METRIC

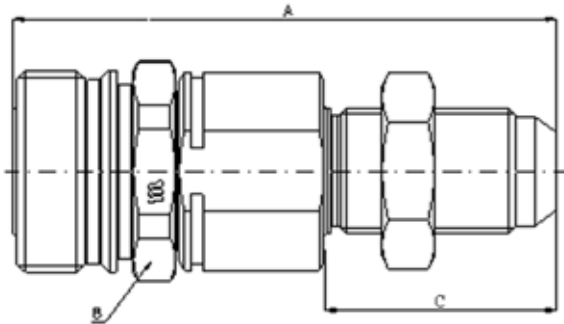

### Q0501141A

METRIC TERMINATION ENDS  
TO DIN 3852 X TYPE

SIZE			PART NUMBER	THREAD	DIMENSIONS mm				
DN	inch	Size	Male coupling		A	B	C	D	
12.5	1/2"	-08	Q0501141A-08-18	M18x1,5	53.5	ø45	27	41	

### SAE

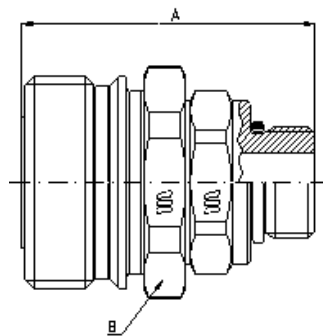

### Q04911300A

SAE TERMINATION END  
TO SAE J1926-3

SIZE			PART NUMBER	THREAD	DIMENSIONS mm				
DN	inch	Size	Male coupling		A	B			
12.5	1/2"	-08	Q04911300A-08-08	3/4"-16 UNF	50	36			

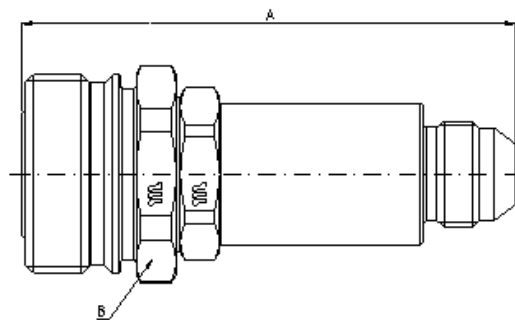

### Q04711250A

SAE TERMINATION ENDS  
TO ISO 8434-2

SIZE			PART NUMBER	THREAD	DIMENSIONS mm				
DN	inch	Size	Male coupling		A	B			
12.5	1/2"	-08	Q04911250A-08-08	3/4"-16 UNF	89.5	36			



SAE

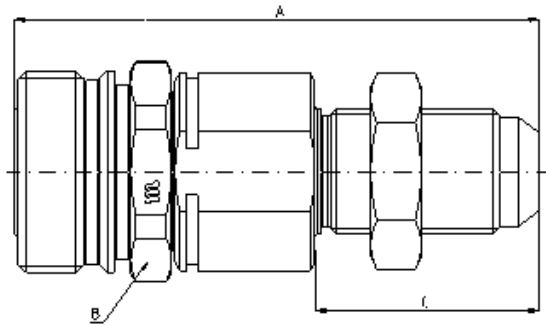

### Q04911230A

SAE TERMINATION ENDS



TO ISO 8434-2

BULKHEAD

SIZE			PART NUMBER	THREAD	DIMENSIONS mm				
DN	inch	Size	Male coupling		A	B	C		
12.5	1/2"	-08	Q04911230A-08-10	7/8"-14 UNF	94.8	36	40.1		





		
<b>SIZE</b>	<b>WORKING PRESSURE (Dynamic)</b>	<b>MINIMUM BURST PRESSURE</b>

mm	inch	dash	MPa	PSI	Male	
					MPa	PSI
5	1/8	02	42	6090	250	36250

### Product description:

- Quick coupling purposely designed to easily access hydraulic systems for performance testing
- Installing male coupling in several parts of the hydraulic system, a reliable diagnosis can be carried out in a short time
- Connection by pushing the male coupling in the female of vice-versa
- Disconnection by pulling back the sleeve
- Retaining by ball latching system
- Shut-off system by flat valve
- Wide range of termination ends available on request and protective cap
- Interchangeability according to ISO 15171-1 and SAE J1502

<b>Material</b>	Male coupling in steel, with some hardened areas in correspondence to the most stressed points. Carbonitrided valve, spring in C98 steel and seals in NBR (other materials on request)
<b>Working Temperature</b>	-22°F up to +230°F (-30°C up to +110°C) For different temperature range, the coupling can be assembled with specific seals
<b>Safety Factor</b>	4:1 for dynamic pressures
<b>Impulse Pressures</b>	1,000,000 cycles at 133% of the rated one (freq. 1Hz)
<b>Test Specifications</b>	ISO 15171-1, SAE J1502 and ISO 7241-2



### METRIC

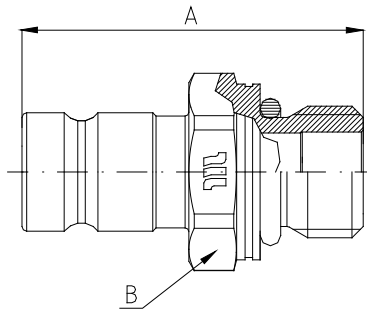

## Q0451190A

METRIC TERMINATION ENDS

TO ISO 6149-2

SIZE			PART NUMBER	THREAD	DIMENSIONS mm					
DN	inch	Size	Female coupling		A	B				
5	1/8"	-02	Q0451190A-02-14	M14x1,5	36.4	19				

### NPT

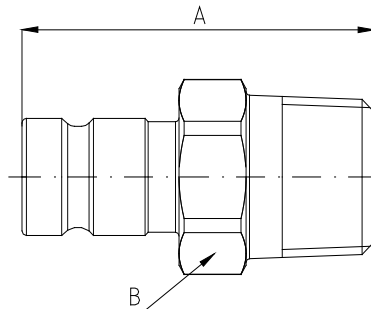

## Q04511280A

NPT TERMINATION ENDS

TO ANSI B 1.20.3

SIZE			PART NUMBER	THREAD	DIMENSIONS mm					
DN	inch	Size	Female coupling		A	B				
5	1/8"	-02	Q04511280A-02-02	1/8" NPTF	39.8	17				
			Q04511280A-02-04	1/4" NPTF	44.3	17				
			Q04511280A-02-06	3/8" NPTF	39.9	19				

### SAE

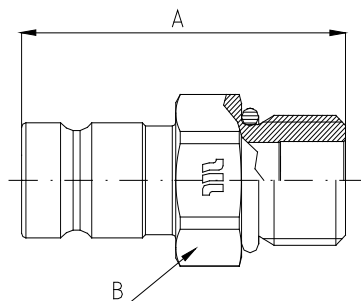

## Q04511320A

ORB TERMINATION ENDS

TO SAE J1926-2

S SERIES

SIZE			PART NUMBER	THREAD	DIMENSIONS mm					
DN	inch	Size	Female coupling		A	B				
5	1/8"	-02	Q04511320A-02-04	7/16"-20	40.8	17				
			Q04511320A-02-06	9/16"-18 UNF	37.4	17				

SAE

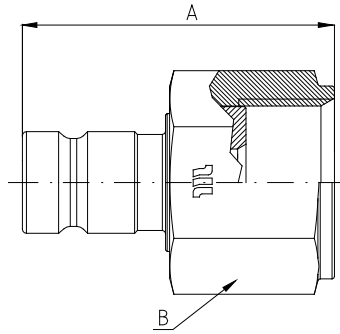

**Q04511241A**  
 ORFS TERMINATION ENDS  
 TO SAE J1453

SIZE			PART NUMBER	THREAD	DIMENSIONS mm					
DN	inch	Size	Female coupling		A	B				
5	1/8"	-02	Q04511241A-02-08	13/16"-16 UN	38.8	24				



SIZE	MPa		FLOW RATE	N	OIL SPILLAGE Connection/Disconnection	MINIMUM BURST PRESSURE	CONNECTION/DISCONNECTION UNDER PRESSURE
WORKING PRESSURE - CONNECTED (Dynamic)	WORKING PRESSURE - DISCONNECTED (Dynamic)	RATED FLOW at 0.2 MPa of pressure drop	CONNECTION EFFORT				

mm	inch	dash	MPa		PSI		l/ min	US GPM	N	lb.	cc.	cubic inch	Male		Female		M & F		
			MPa	PSI	MPa	PSI							MPa	PSI	MPa	PSI			
6.3	¼	04	35	5075	35	5075	15	4.0	130	29.2	0.005	0.0003	160	23200	140	20300	150	21750	Not allowed
10	⅜	06	35	5075	25	3625	53	14.0	130	29.2	0.007	0.0004	140	20300	125	18125	145	21025	Not allowed
12.5	½	08	35	5075	25	3625	98	25.9	140	31.5	0.008	0.0005	135	19575	115	16675	145	21025	Not allowed
16	⅝	10	35	5075	25	3625	109	28.8	150	33.7	0.008	0.0005	150	21750	100	14500	140	20300	Not allowed
19	¾	12	35	5075	25	3625	174	46.0	210	47.2	0.009	0.0005	110	15950	102	15225	145	21025	Not allowed
25	1	16	35	5075	21	3045	203	53.6	230	51.7	0.02	0.0012	100	14500	85	12325	150	21750	Not allowed

Pressure Drop

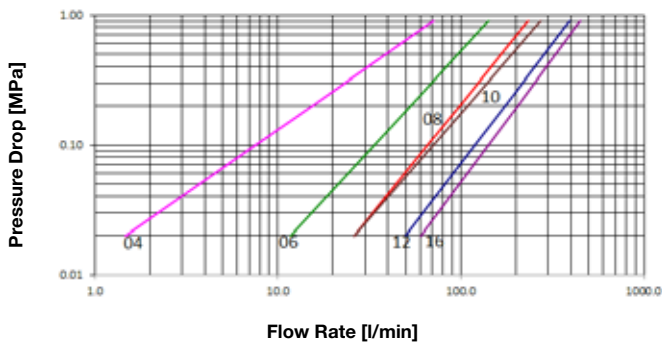

Pressure Drop

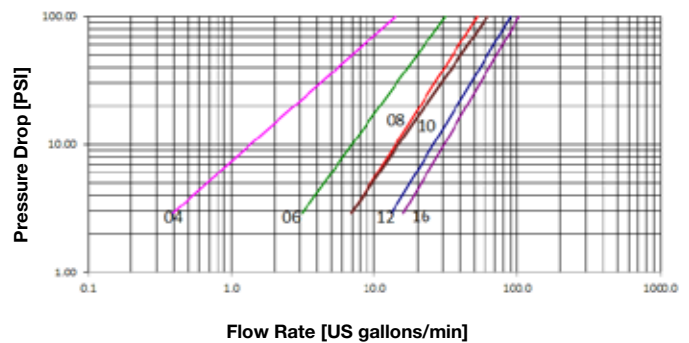

### Product description:

- Flat mating surfaces easily wiped clean to prevent contamination and spillage during connection/disconnection
- Connection is made by pushing the male coupling and disconnection by pulling back the sleeve of the female
- Positive, quick connection of the male into the female by the latching ball system
- Shut-off by flat valve
- Interchangeability according to ISO 16028 and HTMA standards (only for ⅜")
- 1,000,000 cycles at 133% of rated (freq. 1Hz - connected conditions)

<b>Material</b>	Female and male coupling in steel, with some stressed tempered or carbonitrided areas. Springs in AISI and C98 steel, seals in polyurethane and NB. Other materials (VTON, EPDM or any others) on request
<b>Working Temperature</b>	-22°F up to +230°F (-30°C up to +110°C) For other temperatures the coupling is assembled with the specified seals
<b>Safety Factor</b>	4:1 for dynamic pressures
<b>Impulse Pressures</b>	100,000 cycles at 133% of the rated one (freq. 1Hz) in disconnected conditions. 1,000,000 cycles at 133% of rated one (freq. 1Hz) in connected conditions.
<b>Test Specifications</b>	ISO 16028:1997aMD.1.2006 (E) and ISO 7241-2





## FLAT FACE - TERMINATION ENDS

BSP

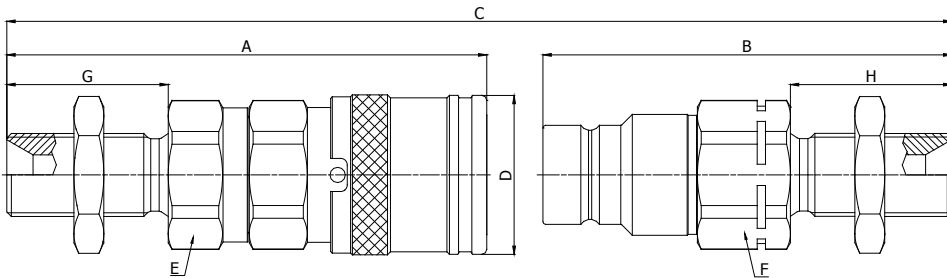

**Q04111040A**

**Q03911040A**

**BSP TERMINATION ENDS**

**TO DIN3852**

**BULKHEAD**

SIZE			PART NUMBER		THREAD	DIMENSIONS mm							
DN	inch	Size	Female coupling	Male coupling		A	B	C	D	E	F	G	H
10	3/8"	-06	Q04111040A-06-06	Q03911040A-06-06	3/8"	99.9	82.5	A+B-16,4	ø32	27	27	32	32

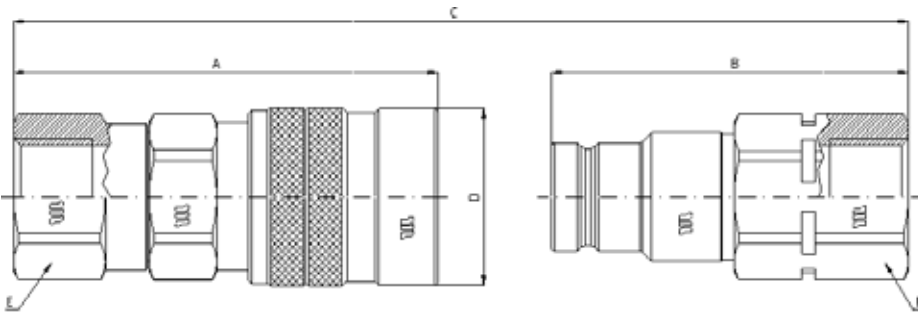

**Q04111041A**

**Q03911041A**

**BSP TERMINATION ENDS**

**TO DIN 3852 X TYPE**

SIZE			PART NUMBER		THREAD	DIMENSIONS mm							
DN	inch	Size	Female coupling	Male coupling		A	B	C	D	E	F		
6.3	1/4"	-04	Q04111041A-04-04	Q03911041A-04-04	1/4"	63.6	52.1	A+B-11,1	ø28	24	22		
			Q04111041A-04-06	Q03911041A-04-06	1/4"	63.6	53.6	A+B-11,1	ø28	24	22		
10	3/8"	-06	Q04111041A-06-06	Q03911041A-06-06	3/8"	74.9	62.5	A+B-15,9	ø32	27	27		
			Q04111041A-06-08	Q03911041A-06-08	1/2"	77.9	65.5	A+B-15,9	ø32	27	27		
12.5	1/2"	-08	Q04111041A-08-08	Q03911041A-08-08	1/2"	84.7	72.5	A+B-17,1	ø38	34	34		
			Q04111041A-08-12	Q03911041A-08-12	3/4"	86.7	74.5	A+B-17,1	ø38	34	34		
16	5/8"	-10	Q04111041A-10-12	Q03911041A-10-12	3/4"	89.9	75.1	A+B-17,6	ø42	34	34		
20	3/4"	-12	Q04111041A-12-12	Q03911041A-12-12	3/4"	105.9	88.5	A+B-21,7	ø48	41	41		
			Q04111041A-12-16	Q03911041A-12-16	1"	108.9	91.5	A+B-21,7	ø48	41	41		
25	1"	-16	Q04111041A-16-16	Q03911041A-16-16	1"	114.5	89.8	A+B-22,9	ø55	50	50		
			Q04111041A-16-20	Q03911041A-16-20	1.1/4"	117	94.8	A+B-22,9	ø55	50	50		

**BSP**

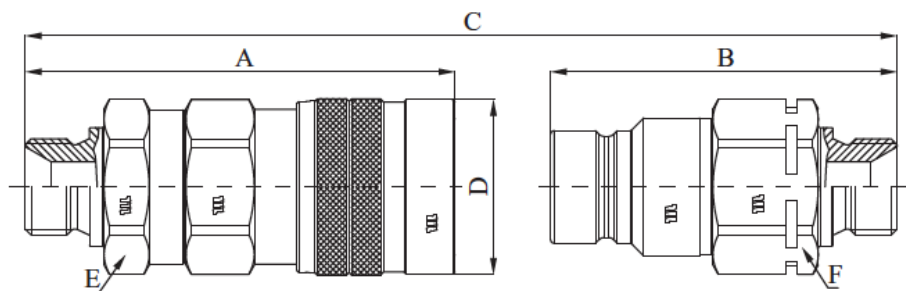

**Q04111050A**

**Q03911050A**

**BSP TERMINATION ENDS**

**TO ISO 8434-6**

SIZE			PART NUMBER		THREAD	DIMENSIONS mm							
DN	inch	Size	Female coupling	Male coupling		A	B	C	D	E	F		
10	3/8"	-06	Q04111050A-06-06	Q03911050A-06-06	3/8"	82.6	65.2	A+B-15,9	ø32	27	27		
			Q04111050A-06-08	Q03911050A-06-08	1/2"	85.1	67.7	A+B-15,9	ø32	27	27		
12.5	1/2"	-08	Q04111050A-08-08	Q03911050A-08-08	1/2"	92.9	77.7	A+B-17,1	ø38	34	34		
			Q04111050A-08-12	Q03911050A-08-12	3/4"	94.9	79.7	A+B-17,1	ø38	34	34		
16	5/8"	-10	Q04111050A-10-12	Q03911050A-10-12	3/4"	95.6	80.3	A+B-17,6	ø42	34	34		

**METRIC**

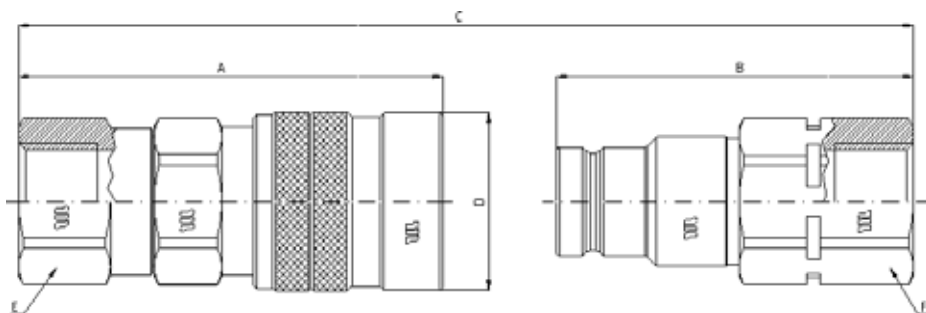

**Q04111141A**

**Q03911141A**

**METRIC TERMINATION ENDS**

**TO ISO 3852-1 X TYPE**

SIZE			PART NUMBER		THREAD	DIMENSIONS mm							
DN	inch	Size	Female coupling	Male coupling		A	B	C	D	E	F		
6.3	1/4"	-04	Q04111141A-04-16	Q03911141A-04-16	M16x1,5	63.6	53.6	A+B-11,1	ø28	24	22		
10	3/8"	-06	Q04111141A-06-18	Q03911141A-06-18	M18x1,5	77.9	62.5	A+B-15,9	ø32	27	27		
			Q04111141A-06-22	Q03911141A-06-22	M22x1,5	77.9	64.5	A+B-15,9	ø32	27	27		

## FLAT FACE - TERMINATION ENDS

METRIC

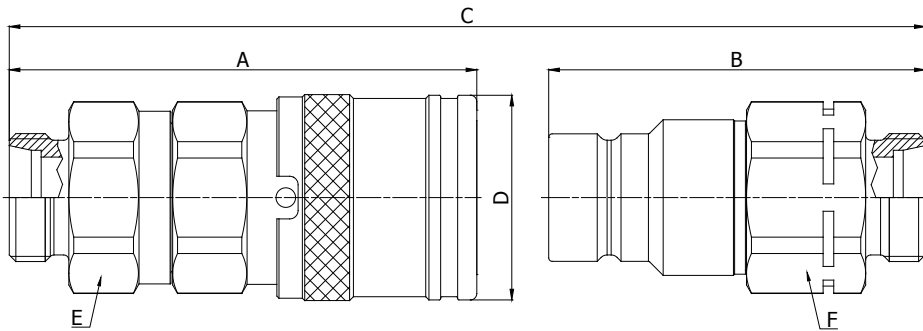

**Q0411110A**

**Q0391110A**

**METRIC TERMINATION END**

**TO ISO 8434-1**

**L SERIES**

SIZE			PART NUMBER		THREAD	DIMENSIONS mm							
DN	inch	Size	Female coupling	Male coupling		A	B	C	D	E	F		
6.3	1/4"	-04	Q0411110A-04-12	Q0391110A-04-12	M16x1,5	68.6	50.1	A+B-11,1	ø28	24	22		
			Q0411110A-04-14	Q0391110A-04-14	M14x1,5	68.6	50.1	A+B-11,1	ø28	24	22		
			Q0411110A-04-16	Q0391110A-04-16	M16x1,5	68.6	50.1	A+B-11,1	ø28	24	22		
10	3/8"	-06	Q0411110A-06-14	Q0391110A-06-14	M14x1,5	77.9	61.5	A+B-15,9	ø32	27	27		
			Q0411110A-06-16	Q0391110A-06-16	M16x1,5	78.9	62.5	A+B-15,9	ø32	27	27		
			Q0411110A-06-18	Q0391110A-06-18	M18x1,5	78.9	61.5	A+B-15,9	ø32	27	27		
			Q0411110A-06-22	Q0391110A-06-22	M22x1,5	79.9	62.5	A+B-15,9	ø32	27	27		
12.5	1/2"	-08	Q0411110A-08-18	Q0391110A-08-18	M18x1,5	86.7	72.5	A+B-17,1	ø38	34	34		
			Q0411110A-08-22	Q0391110A-08-22	M22x1,5	87.7	72.5	A+B-17,1	ø38	34	34		
			Q0411110A-08-26	Q0391110A-08-26	M26x1,5	87.7	72.5	A+B-17,1	ø38	34	34		
20	3/4"	-12	Q0411110A-12-26	Q0391110A-12-26	M26x1,5	101.9	86.5	A+B-21,7	ø48	41	41		
			Q0411110A-12-30	Q0391110A-12-30	M30x2	103.9	88.5	A+B-21,7	ø48	41	41		
25	1"	-16	Q0411110A-16-30	Q0391110A-16-30	M30x2	110.5	79.8	A+B-22,9	ø55	50	50		

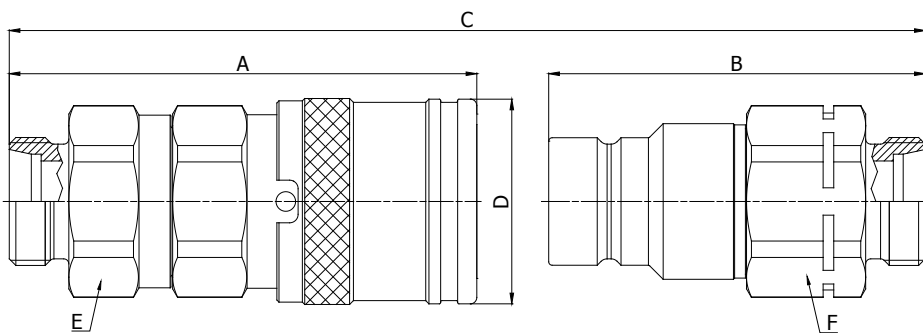

**Q0411120A**

**Q0391120A**

**METRIC TERMINATION END**

**TO ISO 8434-1**

**S SERIES**

SIZE			PART NUMBER		THREAD	DIMENSIONS mm							
DN	inch	Size	Female coupling	Male coupling		A	B	C	D	E	F		
6.3	1/4"	-04	Q0411120A-04-16	Q0391120A-04-16	M16x1,5	69.6	51.1	A+B-11,1	ø28	24	22		
			Q0411120A-04-18	Q0391120A-04-18	M18x1,5	69.6	51.1	A+B-11,1	ø28	24	22		
10	3/8"	-06	Q0411120A-06-18	Q0391120A-06-18	M18x1,5	79.9	62.5	A+B-15,9	ø32	27	27		
			Q0411120A-06-20	Q0391120A-06-20	M20x1,5	79.9	62.5	A+B-15,9	ø32	27	27		
12.5	1/2"	-08	Q0411120A-08-20	Q0391120A-08-20	M20x1,5	87.7	72.5	A+B-17,1	ø38	34	34		
			Q0411120A-08-24	Q0391120A-08-24	M24x1,5	87.7	74.5	A+B-17,1	ø38	34	34		
20	3/4"	-12	Q0411120A-12-30	Q0391120A-12-30	M30x2	105.9	90.5	A+B-21,7	ø48	41	41		

METRIC

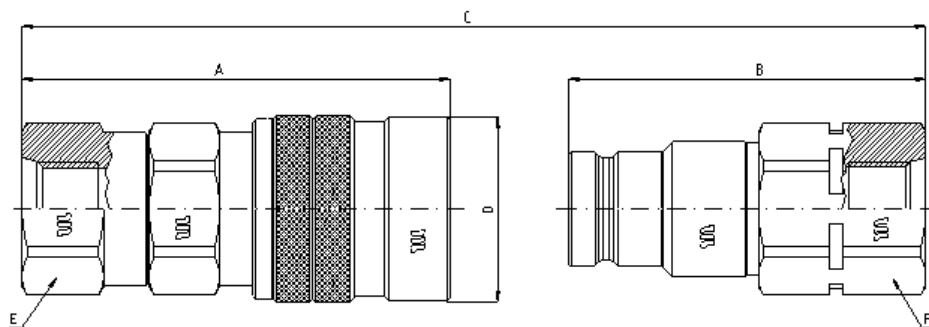

**Q0411191A**

**Q0391191A**

**METRIC TERMINATION ENDS**

**TO ISO 6149-1**

SIZE			PART NUMBER		THREAD	DIMENSIONS mm							
DN	inch	Size	Female coupling	Male coupling		A	B	C	D	E	F		
10	3/8"	-06	Q0411191A-06-16	Q0391191A-06-16	M16x1,5	75.4	63	A+B-15,9	ø32	27	27		
			Q0411191A-06-18	Q0391191A-06-18	M18x1,5	76.9	64.5	A+B-15,9	ø32	27	27		

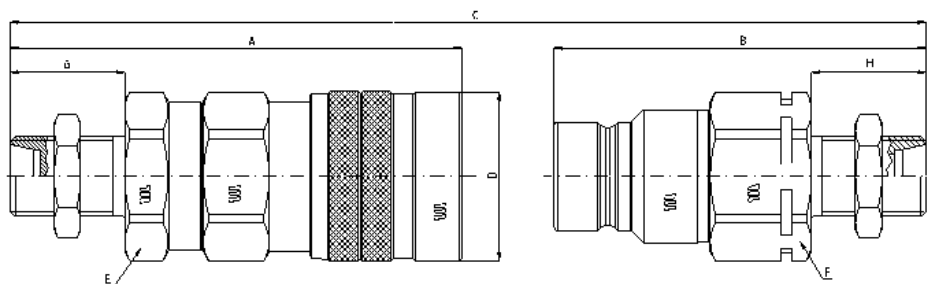

**Q04111770B**

**Q03911770B**

**METRIC TERMINATION END**

**TO ISO 8434-1**

**BULKHEAD L SERIES**

SIZE			PART NUMBER		THREAD	DIMENSIONS mm							
DN	inch	Size	Female coupling	Male coupling		A	B	C	D	E	F	G	H
6.3	1/4"	-04	Q04111770B-04-12	Q03911770B-04-12	M12x1,5	82.6	65.1	A+B-11,1	ø28	24	22	25	25
			Q04111770B-04-14	Q03911770B-04-14	M14x1,5	82.6	64.1	A+B-11,1	ø28	24	22	25	25
			Q04111770B-04-16	Q03911770B-04-16	M16x1,5	83.6	64.1	A+B-11,1	ø28	24	22	26	26
10	3/8"	-06	Q04111770B-06-16	Q03911770B-06-16	M16x1,5	93.9	76.5	A+B-15,9	ø32	27	27	26	26
			Q04111770B-06-18	Q03911770B-06-18	M18x1,5	93.9	76.5	A+B-15,9	ø32	27	27	26	26
			Q04111770B-06-22	Q03911770B-06-22	M22x1,5	94.9	77.5	A+B-15,9	ø32	27	27	27	27
12.5	1/2"	-08	Q04111770B-08-18	Q03911770B-08-18	M18x1,5	101.7	86.5	A+B-17,1	ø38	34	34	26	26
			Q04111770B-08-22	Q03911770B-08-22	M22x1,5	102.7	87.5	A+B-17,1	ø38	34	34	27	27
			Q04111770B-08-26	Q03911770B-08-26	M26x1,5	103.7	88.5	A+B-17,1	ø38	34	34	28	28
20	3/4"	-12	Q04111770B-12-26	Q03911770B-12-26	M26x1,5	114.9	102.5	A+B-21,7	ø48	41	41	29	29
			Q04111770B-12-30	Q03911770B-12-30	M30x2	118.9	106.5	A+B-21,7	ø48	41	41	32	32

## FLAT FACE HIGH PRESSURE - TERMINATION ENDS

METRIC

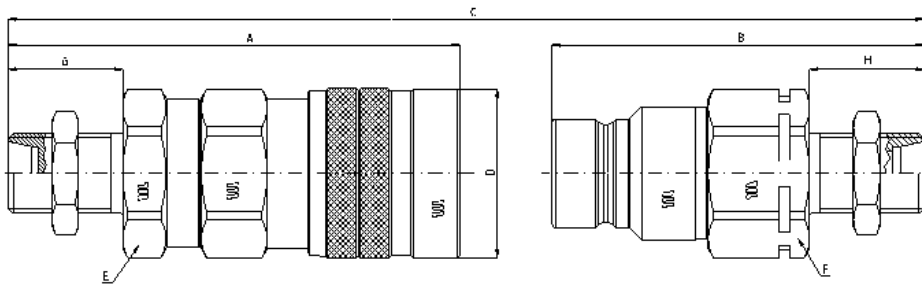

**Q04111870B**

**Q03911870B**

**METRIC TERMINATION END**

**TO ISO 8434-1**

**BULKHEAD S SERIES**

SIZE			PART NUMBER		THREAD	DIMENSIONS mm							
DN	inch	Size	Female coupling	Male coupling		A	B	C	D	E	F	G	H
6.3	1/4"	-04	Q04111870B-04-16	Q03911870B-04-16	M16x1,5	83.6	65.1	A+B-11,1	ø28	24	22	27	27
			Q04111870B-04-18	Q03911870B-04-18	M18x1,5	83.6	65.1	A+B-11,1	ø28	24	22	27	27
10	3/8"	-06	Q04111870B-06-18	Q03911870B-06-18	M18x1,5	94.9	77.5	A+B-15,9	ø32	27	27	27	27
			Q04111870B-06-20	Q03911870B-06-20	M20x1,5	94.9	77.5	A+B-15,9	ø32	27	27	27	27
12.5	1/2"	-08	Q04111870B-08-24	Q03911870B-08-24	M24x1,5	104.7	89.5	A+B-17,1	ø38	34	34	29	29
20	3/4"	-12	Q04111870B-12-30	Q03911870B-12-30	M30x2	119.9	108.5	A+B-21,7	ø48	41	41	34	34
25	1"	-16	Q04111870B-16-36	Q03911870B-16-36	M36x2	128.5	101.8	A+B-22,9	ø55	50	50	36	36

NPT

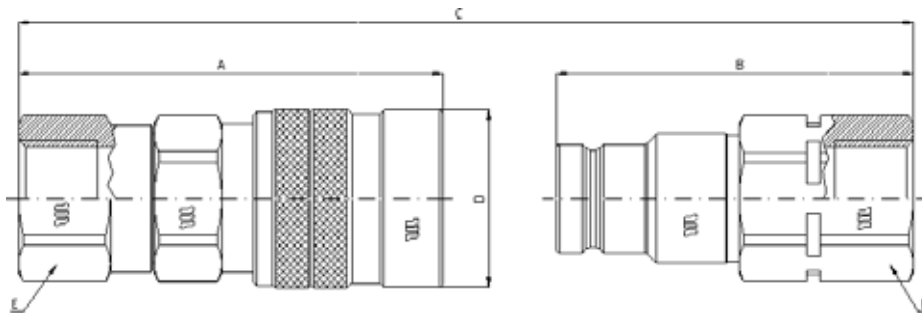

**Q04111341A**

**Q03911341A**

**NPTF TERMINATION END**

**TO ANSI B 1.20.3**

SIZE			PART NUMBER		THREAD	DIMENSIONS mm							
DN	inch	Size	Female coupling	Male coupling		A	B	C	D	E	F		
6.3	1/4"	-04	Q04111341A-04-04	Q03911341A-04-04	1/4" NPTF	63.6	52.1	A+B-11,1	ø28	24	22		
10	3/8"	-06	Q04111341A-06-06	Q03911341A-06-06	3/8" NPTF	74.9	62.5	A+B-15,9	ø32	27	27		
			Q04111341A-06-08	Q03911341A-06-08	1/2" NPTF	77.9	65.5	A+B-15,9	ø32	27	27		
12.5	1/2"	-08	Q04111341A-08-08	Q03911341A-08-08	1/2" NPTF	84.7	72.5	A+B-17,1	ø38	34	34		
			Q04111341A-08-12	Q03911341A-08-12	3/4" NPTF	86.7	74.5	A+B-17,1	ø38	34	34		
16	5/8"	-10	Q04111341A-10-08	Q03911341A-10-08	1/2" NPTF	87.9	73.1	A+B-17,6	ø42	34	34		
			Q04111341A-10-12	Q03911341A-10-12	3/4" NPTF	89.9	75.1	A+B-17,6	ø42	34	34		
20	3/4"	-12	Q04111341A-12-12	Q03911341A-12-12	3/4" NPTF	105.9	88.5	A+B-21,7	ø48	41	41		
			Q04111341A-12-16	Q03911341A-12-16	1" NPTF	108.9	91.5	A+B-21,7	ø48	41	41		
25	1"	-16	Q04111341A-16-16	Q03911341A-16-16	1" NPTF	114.5	89.8	A+B-22,9	ø55	50	50		
			Q04111341A-16-20	Q03911341A-16-20	1.1/4" NPTF	116.6	94.8	A+B-23,3	ø55	50	50		

SAE

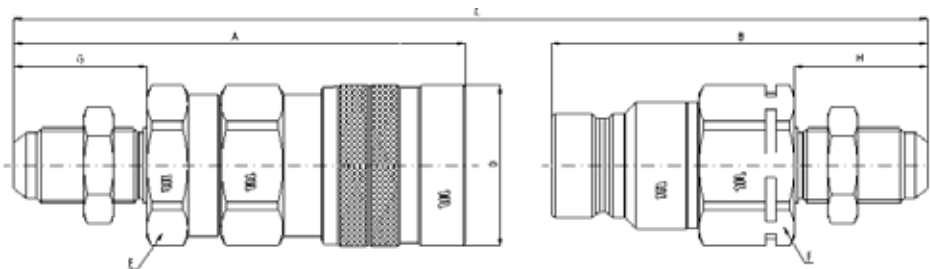

**Q04111230A**

**Q03911230A**

SAE TERMINATION END

TO ISO 8434-2

BULKHEAD

SIZE			PART NUMBER		THREAD	DIMENSIONS mm							
DN	inch	Size	Female coupling	Male coupling		A	B	C	D	E	F	G	H
10	3/8"	-06	Q04111230A-06-08	Q03911230A-06-08	3/4"-16 UNF	105.5	88.1	A+B-15,9	ø32	27	27	36.6	36.6
			Q04111230A-06-10	Q03911230A-06-10	7/8"-14 UNF	109	91.6	A+B-15,9	ø32	27	27	40.1	40.1
12.5	1/2"	-08	Q04111230A-08-10	Q03911230A-08-10	7/8"-14 UNF	116.8	101.6	A+B-17,1	ø38	34	34	40.1	40.1
			Q04111230A-08-12	Q03911230A-08-12	1.1/16"-12 UN	121.1	105.9	A+B-17,1	ø38	34	34	44.4	44.4

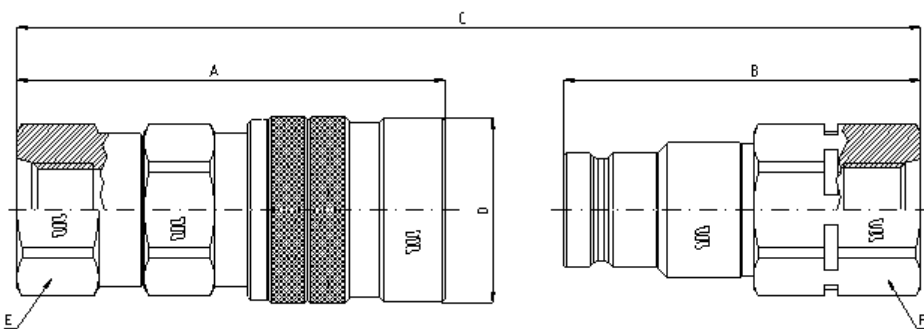

**Q04111301A**

**Q03911301A**

SAE TERMINATION END

TO SAE J1926-1

SIZE			PART NUMBER		THREAD	DIMENSIONS mm							
DN	inch	Size	Female coupling	Male coupling		A	B	C	D	E	F		
6.3	1/4"	-04	Q04111301A-04-06	Q03911301A-04-06	9/16"-18 UNF	63.6	53.6	A+B-11,1	ø28	24	22		
10	3/8"	-06	Q04111301A-06-06	Q03911301A-06-06	9/16"-18 UNF	75.4	63	A+B-15,9	ø32	27	27		
			Q04111301A-06-08	Q03911301A-06-08	3/4"-16 UNF	77.4	65	A+B-15,9	ø32	27	27		
12.5	1/2"	-08	Q04111301A-06-10	Q03911301A-06-10	7/8"-14 UNF	79.9	67.5	A+B-15,9	ø32	27	27		
			Q04111301A-08-08	Q03911301A-08-08	3/4"-16 UNF	84.2	72	A+B-17,1	ø38	34	34		
12.5	1/2"	-08	Q04111301A-08-10	Q03911301A-08-10	7/8"-14 UNF	86.7	74.5	A+B-17,1	ø38	34	34		
			Q04111301A-08-12	Q03911301A-08-12	1.1/16"-12 UN	89.7	77.5	A+B-17,1	ø38	34	34		
16	5/8"	-10	Q04111301A-10-08	Q03911301A-10-08	3/4"-16 UNF	87.4	72.6	A+B-17,6	ø42	34	34		
			Q04111301A-10-10	Q03911301A-10-10	7/8"-14 UNF	89.9	75.1	A+B-17,6	ø42	34	34		
16	5/8"	-10	Q04111301A-10-12	Q03911301A-10-12	1.1/16"-12 UN	92.9	78.1	A+B-17,6	ø42	34	34		
			Q04111301A-12-12	Q03911301A-12-12	1.1/16"-12 UN	108.9	91.5	A+B-21,7	ø48	41	41		
20	3/4"	-12	Q04111301A-12-16	Q03911301A-12-16	1.5/16"-12 UN	108.9	91.5	A+B-21,7	ø48	41	41		
			Q04111301A-16-16	Q03911301A-16-16	1.5/16"-12 UN	114.5	89.8	A+B-22,9	ø55	50	50		

## FLAT FACE HIGH PRESSURE - TERMINATION ENDS

ORFS

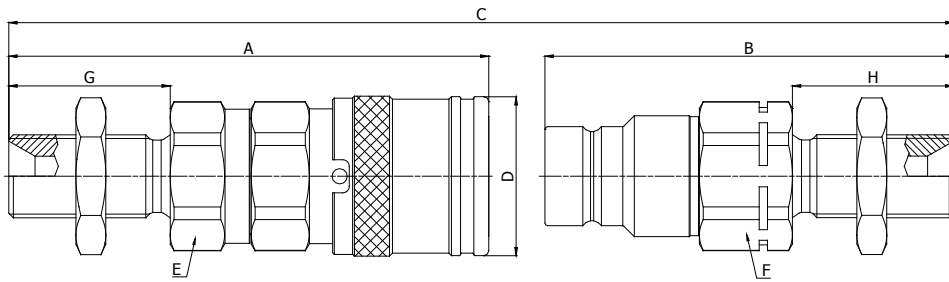

**Q04111270A**

**Q03911270A**

**ORFS TERMINATION ENDS**

**TO ISO 8434-3**

**BULKHEAD**

SIZE			PART NUMBER		THREAD	DIMENSIONS mm							
DN	inch	Size	Female coupling	Male coupling		A	B	C	D	E	F	G	H
10	3/8"	-06	Q04111270A-06-08	Q03911270A-06-08	13/16"-16 UN	104.4	87	A+B-16,4	ø32	27	27	36.5	36.5





## FLAT FACE HIGH PRESSURE



SIZE	WORKING PRESSURE - CONNECTED (Dynamic)	WORKING PRESSURE - DISCONNECTED (Dynamic)	RATED FLOW at 0.2 MPa of pressure drop	CONNECTION EFFORT	OIL SPILLAGE Connection/ Disconnection	MINIMUM BURST PRESSURE	CONNECTION/ DISCONNECTION UNDER PRESSURE
------	--	---	--	-------------------	--	------------------------	--

mm	inch	dash	MPa		PSI		l/ min	US GPM	N	lb.	cc.	cubic inch	Male		Female		M & F		
			MPa	PSI	MPa	PSI							MPa	PSI	MPa	PSI			
6.3	1/4	04	See MQS-F																
10	3/8	06	35	5075	35	5075	44	11.6	130	29.2	0.007	0.0004	150	21750	140	20300	170	24650	Not allowed
12.5	1/2	08	35	5075	35	5075	84	22.2	140	31.5	0.008	0.0005	140	20300	140	20300	160	23200	Not allowed
16	5/8	10	35	5075	35	5075	108	28.5	150	33.7	0.008	0.0005	140	20300	160	23200	160	23200	Not allowed
19	3/4	12	35	5075	35	5075	148	39.1	210	47.2	0.009	0.0005	140	20300	140	20300	160	23200	Not allowed
25	1	16	35	5075	35	5075	224	59.2	230	51.7	0.02	0.0012	140	20300	140	20300	160	23200	Not allowed

Pressure Drop

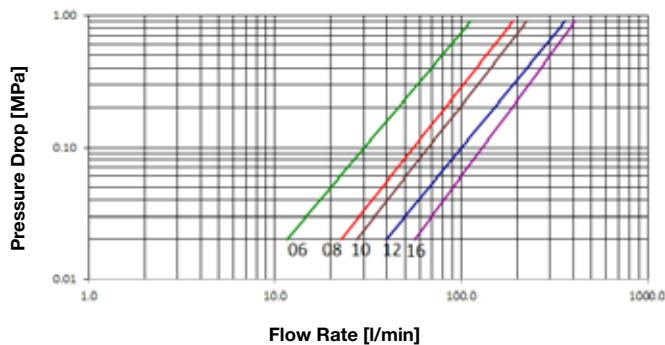

Pressure Drop

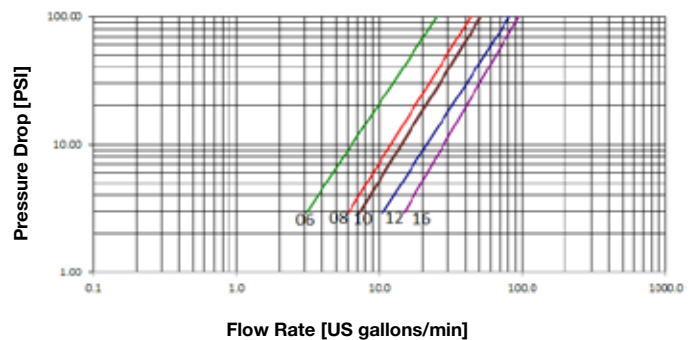

### Product description:

- MQS-FH is the flat-face line for heavy-duty application setting with 35MPa of working pressure in connected and disconnected conditions
- Push connection and pulling back the sleeve for disconnection with safety device
- Interchangeable with ISO 16028
- 1 Million impulse cycles qualified

<b>Material</b>	Female & male couplings in high grade carbon steel with hardened areas in correspondence to the most stressed points. Male vs. female Sealing system in new Polyurethane compound; other seals in NBR with back-up in PTFE.
<b>Working Temperature</b>	-30°C to +110°C
<b>Safety Factor</b>	4.1 in CONNECTED & DISCONNECTED conditions
<b>Impulse Pressures</b>	1,000,000 cycles at 133% of rated one (freq. 1Hz) in
<b>Test Specifications</b>	ISO 16028; ISO7241-2



## FLAT FACE HIGH PRESSURE - TERMINATION ENDS

**BSP**

**Q04411041**

**Q04311041**

**BSP TERMINATION ENDS  
TO DIN 3852 X TYPE**

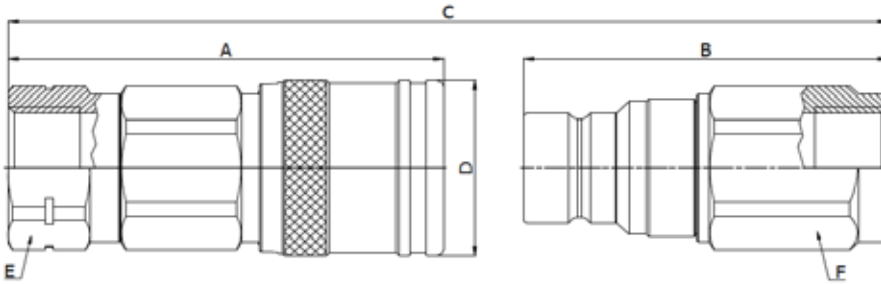

SIZE			PART NUMBER		THREAD	DIMENSIONS mm							
DN	inch	Size	Female coupling	Male coupling		A	B	C	D	E	F		
10	3/8"	-06	Q04411041A-06-06	Q04311041A-06-06	3/8"	78.3	63.8	A+B-15,9	ø32	27	27		
			Q04411041A-06-08	Q04311041A-06-08	1/2"	81.3	67.8	A+B-15,9	ø32	27	27		
12.5	1/2"	-08	Q04411041A-08-08	Q04311041A-08-08	1/2"	88.5	71.3	A+B-17,1	ø38	34	34		
			Q04411041A-08-12	Q04311041A-08-12	3/4"	90.5	75.8	A+B-17,1	ø38	34	34		
16	5/8"	-10	Q04411041A-10-12	Q04311041A-10-12	3/4"	94.6	76.4	A+B-17,1	ø42	36	34		
20	3/4"	-12	Q04411041A-12-12	Q04311041A-12-12	3/4"	108	89.8	A+B-21,7	ø48	41	41		
			Q04411041A-12-16	Q04311041A-12-16	1"	111	92.8	A+B-21,7	ø48	41	41		
25	1"	-16	Q04411041A-16-16	Q04311041A-16-16	1"	119.4	92.1	A+B-22,9	ø55	50	50		
			Q04411041A-16-20	Q04311041A-16-20	1.1/4"	122.4	97.1	A+B-22,9	ø55	50	50		

**NPT**

**Q04411341**

**Q04311341**

**NPTF TERMINATION END  
TO ANSI B 1.20.3**

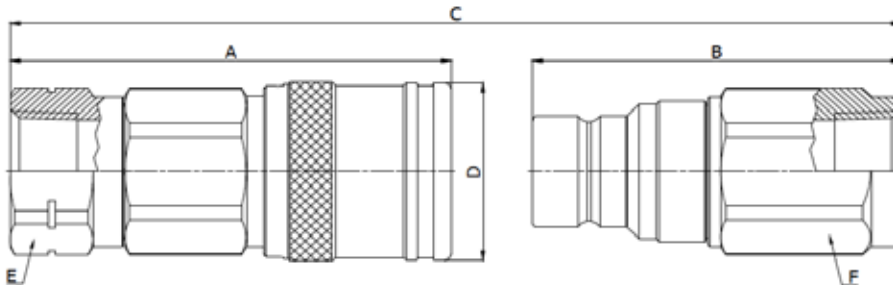

SIZE			PART NUMBER		THREAD	DIMENSIONS mm							
DN	inch	Size	Female coupling	Male coupling		A	B	C	D	E	F		
10	3/8"	-06	Q04411341A-06-06	Q04311341A-06-06	3/8"-NPT	78.3	63.8	A+B-15,9	ø32	27	27		
12.5	1/2"	-08	Q04411341A-08-08	Q04311341A-08-08	1/2"-NPT	88.5	71.3	A+B-17,1	ø38	34	34		
20	3/4"	-12	Q04411341A-12-12	Q04311341A-12-12	3/4"-NPT	108	89.8	A+B-21,7	ø48	41	41		
25	1"	-16	Q04411341A-16-16	Q04311341A-16-16	1"-NPT	119.4	92.1	A+B-22,9	ø55	50	50		

SAE

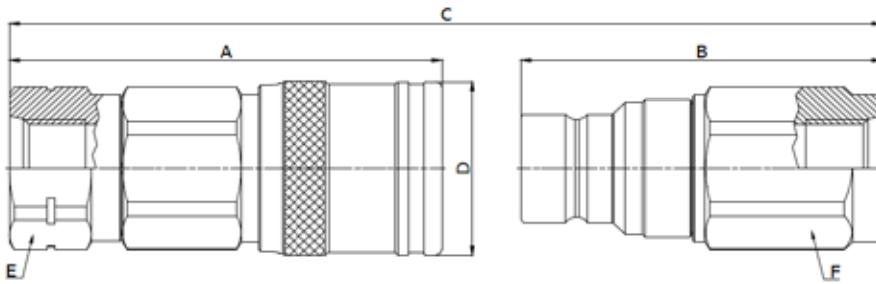

**Q04411301**

**Q04311301**

**SAE TERMINATION END**

**TO SAE J1926-1**

SIZE			PART NUMBER		THREAD	DIMENSIONS mm							
DN	inch	Size	Female coupling	Male coupling		A	B	C	D	E	F		
10	3/8"	-06	Q04411301A-06-08	Q04311301A-06-08	3/4"-16UNF	80,8	66,8	A+B-15,9	ø32	27	27		
			Q04411301A-08-10	Q04311301A-08-10								7/8"-14UNF	90,5
12.5	1/2"	-08	Q04411301A-08-12	Q04311301A-08-12	1.1/16"-12UNF	93,5	78,8	A+B-17,1	ø38	34	34		



## FLAT FACE MALE CONNECTABLE UNDER PRESSURE

	MPa		→	N	Oil Spillage	Minimum Burst Pressure	Connection/Disconnection Under Pressure
SIZE	WORKING PRESSURE - CONNECTED (Dynamic)	WORKING PRESSURE - DISCONNECTED (Dynamic)	RATED FLOW at 0.2 MPa of pressure drop	CONNECTION EFFORT	OIL SPILLAGE Connection/Disconnection	MINIMUM BURST PRESSURE	CONNECTION/ DISCONNECTION UNDER PRESSURE

mm	inch	dash	MPa	PSI	MPa	PSI	l/min	US GPM	N	lb.	cc.	cubic inch	Male		M & F		Connection allowed
													MPa	PSI	MPa	PSI	
10	3/8	06	35	5075	35	5075	56	14.8	150	33.7	0.007	0.0004	170	24650	140	20300	Connection allowed
12.5	1/2	08	35	5075	35	5075	85	22.5	180	40.5	0.008	0.0005	170	24650	140	20300	Connection allowed
16	5/8	10	35	5075	35	5075	99	26.2	200	45.0	0.008	0.0005	170	24650	140	20300	Connection allowed
19	3/4	12	35	5075	35	5075	131	34.6	200	45.0	0.009	0.0005	140	20300	150	21750	Connection allowed
25	1	16	35	5075	35	5075	170	44.9	220	49.5	0.02	0.0012	140	23200	160	23200	Connection allowed

Pressure Drop

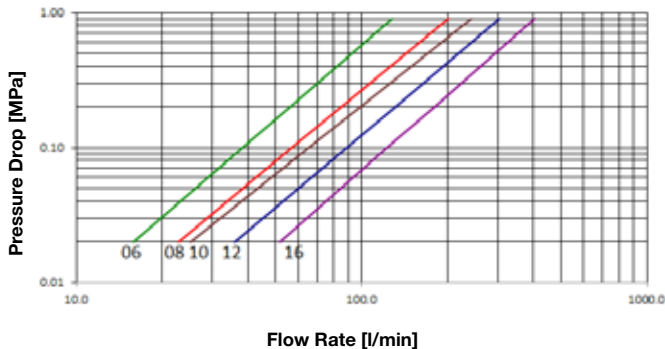

Pressure Drop

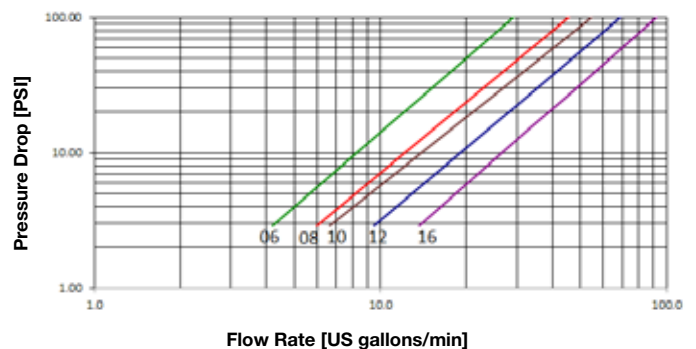

### Product description:

- Triple valve system that guarantees connection under pressure (female part always with OMPa) safely
- Low connection effort during connection under pressure
- Working pressure 35MPa
- Interchangeable according to ISO 16028:1997aMD.1:2006 (E)
- Sealing system with flat valve
- Polyurethane seals
- Compact design
- Wide range of termination ends

<b>Material</b>	Couplings in steel with some stressed area hardened, carbonitrided valve, springs in C98 steel, seals in polyurethane and NBR, back-up ring PTFE
<b>Working Temperature</b>	-22°F up to +230°F (-30°C up to +110°C)
<b>Safety Factor</b>	4:1 for dynamic pressures
<b>Impulse Pressures</b>	1,000,000 cycles (connected and disconnected conditions) at 133% of the rated one (freq. 1Hz)
<b>Test Specifications</b>	ISO 7241-2 and ISO 16028:1997aMD.1.2006 (E)



## FLAT FACE MALE CONNECTABLE UNDER PRESSURE - TERMINATION ENDS

BSP

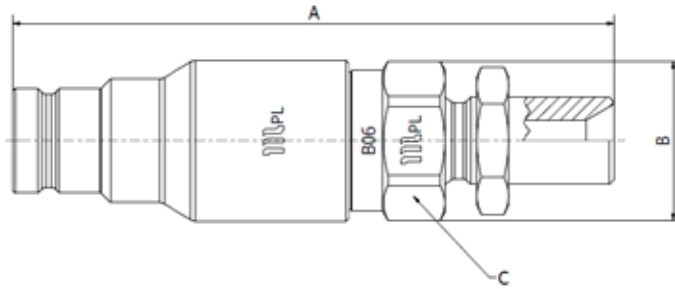

### Q04011040A

BSP TERMINATION ENDS

TO DIN 3852-2

BULKHEAD

SIZE			PART NUMBER	THREAD	DIMENSIONS mm					
DN	inch	Size	Male coupling		A	B	C			
10	3/8"	-06	Q04011040A-06-06	3/8"	113.5	ø30	27			

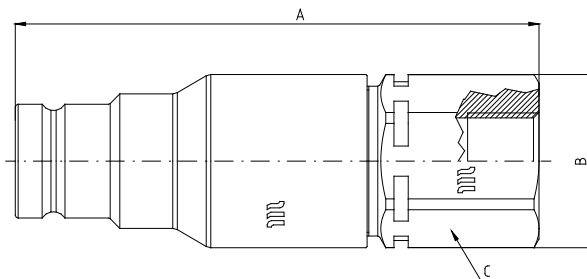

### Q04011041A

BSP TERMINATION ENDS

TO DIN 3852 TYPE

SIZE			PART NUMBER	THREAD	DIMENSIONS mm					
DN	inch	Size	Male coupling		A	B	C			
10	3/8"	-06	Q04011041A-06-06	3/8"	91.7	ø30	27			
			Q04011041A-06-08	1/2"	94	ø30	27			
12	1/2"	-08	Q04011041A-08-08	1/2"	98	ø38	34			
			Q04011041A-08-12	3/4"	100	ø38	34			
16	5/8"	-10	Q04011041A-10-12	3/4"	114.3	ø40	36			
19	3/4"	-12	Q04011041A-12-12	3/4"	118	ø45	41			
			Q04011041A-12-16	1"	122	ø45	41			
25	1"	-16	Q04011041A-16-16	1"	126.3	ø55	50			
			Q04011041A-16-20	1.1/4"	130	ø55	50			

## FLAT FACE MALE CONNECTABLE UNDER PRESSURE - TERMINATION ENDS

NPT

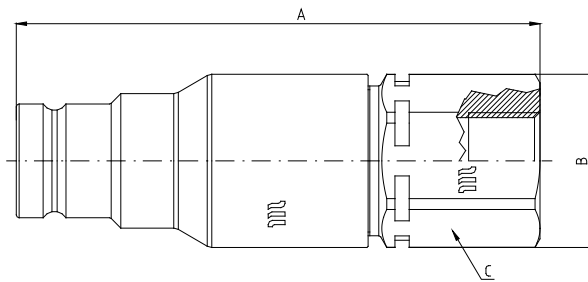

### Q04011341A

NPTF TERMINATION END

TO ANSI B 1.20.3

SIZE			PART NUMBER	THREAD	DIMENSIONS mm					
DN	inch	Size	Male coupling		A	B	C			
10	3/8"	-06	Q04011341A-06-06	3/8" NPTF	91.7	ø30	27			
			Q04011341A-06-08	1/2" NPTF	94	ø30	27			
12	1/2"	-08	Q04011341A-08-08	1/2" NPTF	98	ø38	34			
			Q04011341A-08-12	3/4" NPTF	100	ø38	34			
16	5/8"	-10	Q04011341A-10-12	3/4" NPTF	114.3	ø40	36			
19	3/4"	-12	Q04011341A-12-12	3/4" NPTF	118	ø45	41			
			Q04011341A-12-16	1" NPTF	122	ø45	41			
25	1"	-16	Q04011341A-16-20	1.1/4" NPTF	130	ø55	50			

SAE

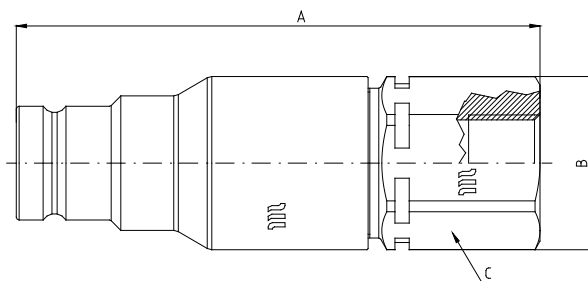

### Q04011301A

SAE TERMINATION ENDS

TO SAE J1926-1

SIZE			PART NUMBER	THREAD	DIMENSIONS mm					
DN	inch	Size	Male coupling		A	B	C			
10	3/8"	-06	Q04011301A-06-08	3/4" 16UNF	94.2	ø30	27			
12	1/2"	-08	Q04011301A-08-10	7/8" -14 UNF	100	ø38	34			
			Q04011301A-08-12	1.1/16"-12UN	103	ø38	34			
19	3/4"	-12	Q04011301A-12-16	1.5/16"-12UN	125	ø45	41			



## FLAT FACE SCREW TYPE



SIZE	WORKING PRESSURE - CONNECTED (Dynamic)	WORKING PRESSURE - DISCONNECTED (Dynamic)	RATED FLOW at 0.2 MPa of pressure drop	TIGHTENING TORQUE	OIL SPILLAGE Connection/ Disconnection	MINIMUM BURST PRESSURE	CONNECTION/ DISCONNECTION UNDER PRESSURE

mm	inch	dash	MPa		PSI		l/ min	US GPM	Nm	cc.	cubic inch	Male		Female		M & F		
			MPa	PSI	MPa	PSI						MPa	PSI	MPa	PSI			
10	3/8	06	35	5075	35	5075	43	11.4	60	0.007	0.0004	160	23200	140	20300	170	24650	Allowed
12.5	1/2	08	35	5075	35	5075	70	18.5	100	0.008	0.0005	170	24650	150	21750	150	21750	Allowed
16	5/8	10	35	5075	35	5075	85	22.5	100	0.008	0.0005	200	29000	160	23200	160	23200	Allowed
19	3/4	12	35	5075	35	5075	135	35.7	150	0.009	0.0005	145	21025	145	21025	160	23200	Allowed
25	1	16	35	5075	35	5075	170	44.9	200	0.02	0.0012	145	21025	145	21025	160	23200	Allowed
38	1 1/2	24	32	4640	32	4640	396	104.6	400	0.05	0.0031	130	18850	130	18850	130	18850	Allowed

Pressure Drop

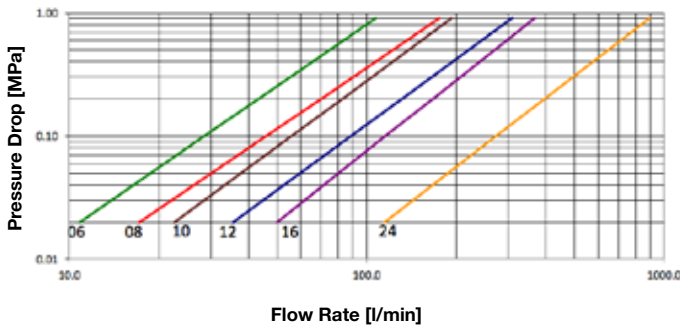

Pressure Drop

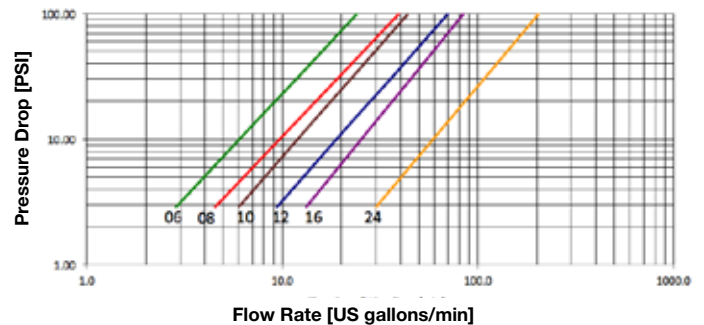

### Product description:

- Screw coupling with quick connection system
- Working pressure 35MPa
- Triple valve system that guarantees connection under pressure safely
- Interchangeable according to Manuli Q.Safe specifications
- Sealing system with flat valve
- Polyurethane seals
- Compact design
- Wide range of termination ends

<b>Material</b>	Couplings in steel with some stressed area hardened, carbonitrided valve, springs in C98 steel, seals in polyurethane and NBR, back-up ring PTFE
<b>Working Temperature</b>	-22°F up to +230°F (-30°C up to +110°C)
<b>Safety Factor</b>	4:1 for dynamic pressures
<b>Impulse Pressures</b>	100,000 cycles at 133% of the rated one (freq. 1Hz) in disconnected conditions. 1,000,000 cycles at 133% of the rated on (freq. 1Hz) in connected conditions
<b>Test Specifications</b>	ISO 7241-2 and ISO 16028:1997aMD.1.2006 (E)

**ASSEMBLY INSTRUCTIONS**

**RECOMMENDED TIGHTENING TORQUE**

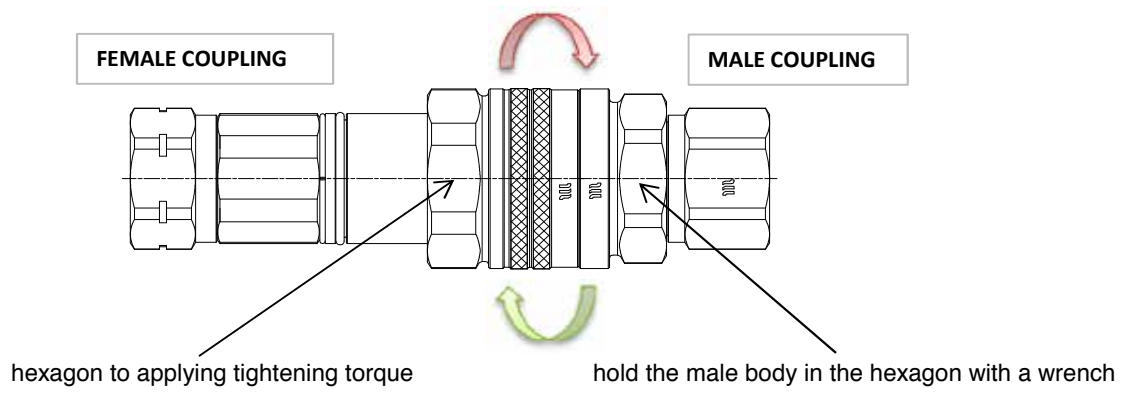

SIZE			TIGHTENING TORQUE (male/female)
DN	inch	Size	Nm
16	5/8"	-10	90
19	3/4"	-12	120
25	1"	-16	200
38	1-1/2"	-24	400

## FLAT FACE SCREW TYPE - TERMINATION ENDS

BSP

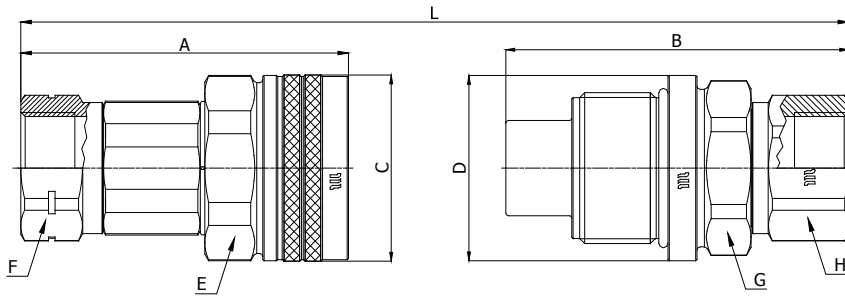

**Q06711041**

**Q06611041**

**BSP TERMINATION ENDS  
TO DIN 3852 X TYPE**

SIZE			PART NUMBER		THREAD	DIMENSIONS mm								
DN	inch	Size	Female coupling	Male coupling		A	B	C	D	E	F	G	H	L
16	5/8"	-10	Q06711041A-10-12	Q06611041A-10-12	3/4"	96.5	Ø55,3	114.3	Ø55	50	36	46	36	A+B-18,9
19	3/4"	-12	Q06711041A-12-12	Q06611041A-12-12	3/4"	109,9	Ø60,3	118.7	Ø60	55	41	50	41	A+B-23,5
			Q06711041A-12-16	Q06611041A-12-16	1"	112.9	Ø60,3	122.1	Ø60	55	41	50	41	A+B-23,5
25	1"	-16	Q06711041A-16-16	Q06611041A-16-16	1"	121.3	Ø70,3	126.3	Ø70	65	50	60	50	A+B-24,5
			Q06711041A-16-20	Q06611041A-16-20	1.1/4"	124.3	Ø70,3	130	Ø70	65	50	60	50	A+B-24,5
38	1½"	-24	Q06711041A-24-24	Q06611041A-24-24	1.½"	167,6	Ø97,3	166	Ø97	90	75	85	75	A+B-31

NPT

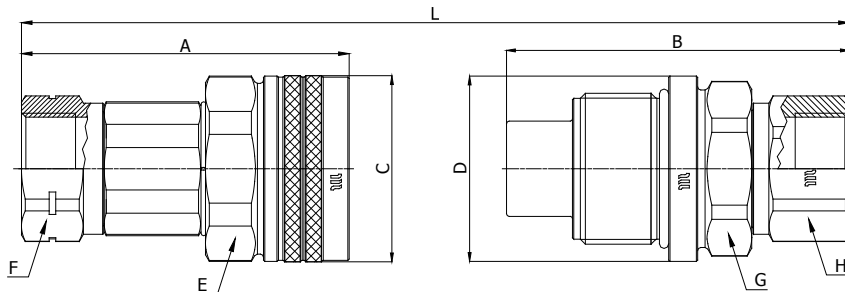

**Q06711341**

**Q06611341**

**NPTF TERMINATION END  
TO ANSI B 1.20.3**

SIZE			PART NUMBER		THREAD	DIMENSIONS mm								
DN	inch	Size	Female coupling	Male coupling		A	B	C	D	E	F	G	H	L
16	5/8"	-10	Q06711341A-10-12	Q06611341A-10-12	3/4" NPTF	96.5	Ø55,3	114.3	Ø55	50	36	46	36	A+B-18,9
19	3/4"	-12	Q06711341A-12-16	Q06611341A-12-16	1" NPTF	112.9	Ø60,3	122.1	Ø60	55	41	50	41	A+B-23,5
25	1"	-16	Q06711341A-16-20	Q06611341A-16-20	1.1/4" NPTF	124.3	Ø70,3	130	Ø70	65	50	60	50	A+B-24,5
38	1½"	-24	Q06711341A-24-24	Q06611341A-24-24	1.1/2" NPTF	167,6	Ø97,3	166	Ø97	90	75	85	75	A+B-31





<b>SIZE</b>	<b>WORKING PRESSURE (Dynamic)</b>	<b>RATED FLOW at 0.2 MPa of pressure drop</b>	<b>OIL SPILLAGE Connection/ Disconnection</b>	<b>MINIMUM BURST PRESSURE</b>	<b>CONNECTION/ DISCONNECTION UNDER PRESSURE</b>

mm	inch	dash	MPa	PSI	l/min	US GPM	cc.	cubic inch	Male		Female		M & F		
									MPa	PSI	MPa	PSI	MPa	PSI	
6.3	¼	04	35	5075	10	2.6	0.8	0.049	145	21025	190	27500	190	27550	Allowed max. 10 MPa
10	⅜	06	35	5075	34	9.0	1.5	0.092	150	21750	160	23200	150	21750	Allowed max. 10 MPa
12.5	½	08	30	4350	61	16.1	2	0.122	130	18850	140	20300	140	20300	Allowed max. 10 MPa
20	¾	12	30	4350	100	26.4	5	0.305	130	18850	130	18850	140	20300	Allowed max. 10 MPa
25	1	16	25	3625	173	45.7	9	0.549	110	15950	110	15950	110	15950	Allowed max. 10 MPa

Pressure Drop

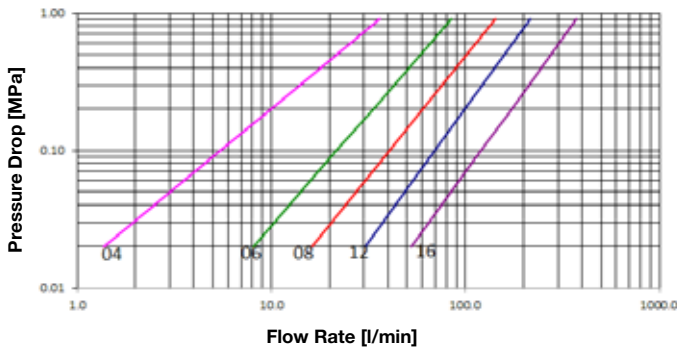

Pressure Drop

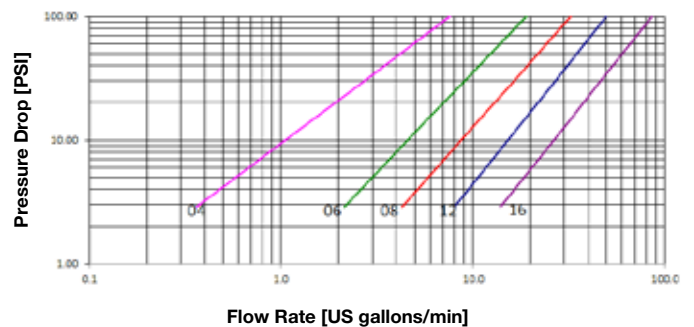

### Product description:

- Screw-type couplings specially designed for heavy duty, high pressure, pressure impulse applications such as hammers, attachments, rock crushers, etc.
- Connection and disconnection is made by screwing the sleeve, also possible with residual pressure in the line
- Connection secured on the thread between the sleeve and the female coupling
- Shut-off by poppet valve
- Hexagon around the male insert to be tightened up or released for maintenance
- Interchangeable with similar products available on the market

<b>Material</b>	Female coupling in steel, male couplings high standard carbon steel. Carbonitrided valve, springs in C98 steel, seals in NBR (other materials available on request) and back-up ring in PTFE
<b>Working Temperature</b>	-22°F up to +230°F (-30°C up to +110°C)
<b>Safety Factor</b>	4:1 for dynamic pressures
<b>Impulse Pressures</b>	100,000 cycles at 133% of the rated one (freq. 1Hz)
<b>Test Specifications</b>	ISO 7241-2



BSP

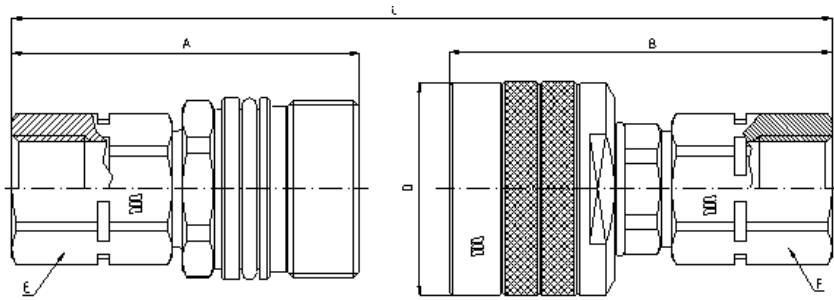

**Q05211041A**

**Q05111041A**

**BSP TERMINATION ENDS  
TO DIN 3852 X TYPE**

SIZE			PART NUMBER		THREAD	DIMENSIONS mm							
DN	inch	Size	Female coupling	Male coupling		A	B	C	D	E	F		
6.3	1/4"	-04	Q05211041A-04-04	Q05111041A-04-04	1/4"	61.5	65.5	A+B-24,5	ø30	19	19		
10	3/8"	-06	Q05211041A-06-04	Q05111041A-06-04	1/4"	68	74	A+B-26,5	ø34	22	22		
			Q05211041A-06-06	Q05111041A-06-06	3/8"	69.5	75.5	A+B-26,5	ø34	22	22		
12.5	1/2"	-08	Q05211041A-08-06	Q05111041A-08-06	3/8"	66.5	74.5	A+B-26,5	ø42	27	27		
			Q05211041A-08-08	Q05111041A-08-08	1/2"	69.5	77.5	A+B-26,5	ø42	27	27		
20	3/4"	-12	Q05211041A-12-08	Q05111041A-12-08	1/2"	80.8	89.3	A+B-31	ø49	34	34		
			Q05211041A-12-12	Q05111041A-12-12	3/4"	82.8	91.3	A+B-31	ø49	34	34		
25	1"	-16	Q05211041A-16-08	Q05111041A-16-08	1/2"	92.3	99.3	A+B-34,5	ø56	41	41		
			Q05211041A-16-12	Q05111041A-16-12	3/4"	92.3	99.3	A+B-34,5	ø56	41	41		
			Q05211041A-16-16	Q05111041A-16-16	1"	95.3	102.3	A+B-34,5	ø56	41	41		

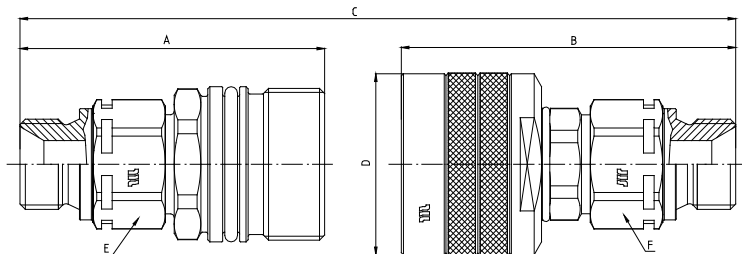

**Q05211050A**

**Q05111050A**

**BSP TERMINATION ENDS  
TO ISO 8434-6**

SIZE			PART NUMBER		THREAD	DIMENSIONS mm							
DN	inch	Size	Female coupling	Male coupling		A	B	C	D	E	F		
12.5	1/2"	-08	Q05211050A-08-06	Q05111050A-08-06	3/8"	69.2	77.2	A+B-26,5	ø42	27	27		
			Q05211050A-08-08	Q05111050A-08-08	1/2"	71.7	79.7	A+B-26,5	ø42	27	27		

METRIC

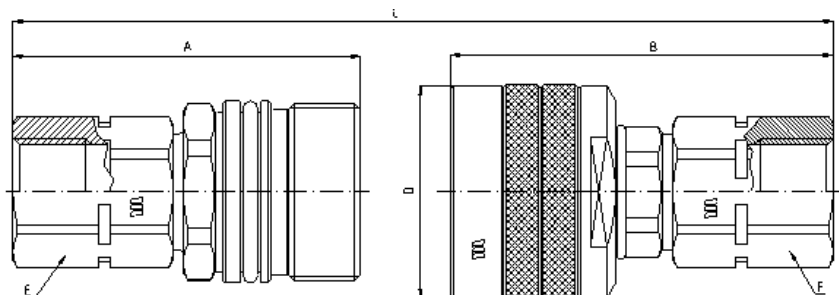

**Q05211141A**

**Q05111141A**

**METRIC TERMINATION ENDS**

**TO ISO 3852-1 X TYPE**

SIZE			PART NUMBER		THREAD	DIMENSIONS mm							
DN	inch	Size	Female coupling	Male coupling		A	B	C	D	E	F		
10	3/8"	-06	Q05211141A-06-16	Q05111141A-06-16	M16x1,5	69.5	75.5	A+B-26,5	ø34	22	22		
12.5	1/2"	-08	Q05211141A-08-18	Q05111141A-08-18	M18x1,5	66.5	74.5	A+B-26,5	ø42	27	27		
			Q05211141A-08-22	Q05111141A-08-22	M22x1,5	68.5	76.5	A+B-26,5	ø42	27	27		

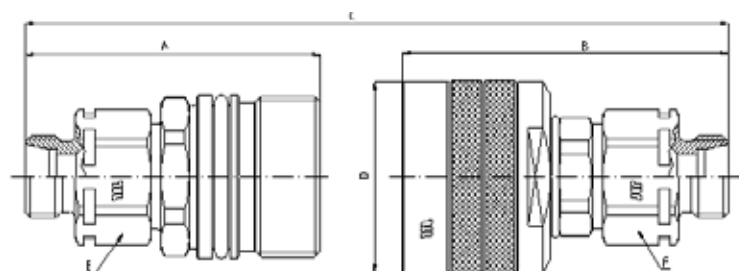

**Q05211110A**

**Q05111110A**

**METRIC TERMINATION END**

**TO ISO 8434-1**

**L SERIES**

SIZE			PART NUMBER		THREAD	DIMENSIONS mm							
DN	inch	Size	Female coupling	Male coupling		A	B	C	D	E	F		
6.3	1/4"	-04	Q05211110A-04-12	Q05111110A-04-12	M12x1,5	59.5	63.5	A+B-24,5	ø30	19	19		
			Q05211110A-04-14	Q05111110A-04-14	M14x1,5	59.5	63.5	A+B-24,5	ø30	19	19		
10	3/8"	-06	Q05211110A-06-12	Q05211110A-06-12	M12x1,5	66	72	A+B-26,5	ø34	22	22		
			Q05211110A-06-14	Q05211110A-06-14	M14x1,5	66	72	A+B-26,5	ø34	22	22		
			Q05211110A-06-16	Q05211110A-06-16	M16x1,5	66	72	A+B-26,5	ø34	22	22		
			Q05211110A-06-18	Q05211110A-06-18	M18x1,5	66	72	A+B-26,5	ø34	22	22		
12.5	1/2"	-08	Q05211110A-08-14	Q05111110A-08-14	M14x1,5	65.5	73.5	A+B-26,5	ø42	27	27		
			Q05211110A-08-16	Q05111110A-08-16	M16x1,5	66.5	74.5	A+B-26,5	ø42	27	27		
			Q05211110A-08-18	Q05111110A-08-18	M18x1,5	65.5	73.5	A+B-26,5	ø42	27	27		
			Q05211110A-08-22	Q05111110A-08-22	M22x1,5	66.5	74.5	A+B-26,5	ø42	27	27		
20	3/4"	-12	Q05211110A-08-26	Q05111110A-08-26	M26x1,5	66.5	74.5	A+B-26,5	ø42	27	27		
			Q05211110A-12-18	Q05111110A-12-18	M18x1,5	80,8	89,3	A+B-31	ø49	34	34		
			Q05211110A-12-22	Q05111110A-12-22	M22x1,5	80,8	89,3	A+B-31	ø49	34	34		
			Q05211110A-12-26	Q05111110A-12-26	M26x1,5	80,8	89,3	A+B-31	ø49	34	34		
25	1"	-16	Q05211110A-12-30	Q05111110A-12-30	M30x2	82,8	91,3	A+B-31	ø49	34	34		
			Q05211110A-16-26	Q05111110A-16-26	M26x1,5	90,3	97,3	A+B-34,5	ø56	41	41		
			Q05211110A-16-30	Q05111110A-16-30	M30x2	92,3	99,3	A+B-34,5	ø56	41	41		
			Q05211110A-16-36	Q05111110A-16-36	M36x2	92,3	99,3	A+B-34,5	ø56	41	41		



METRIC

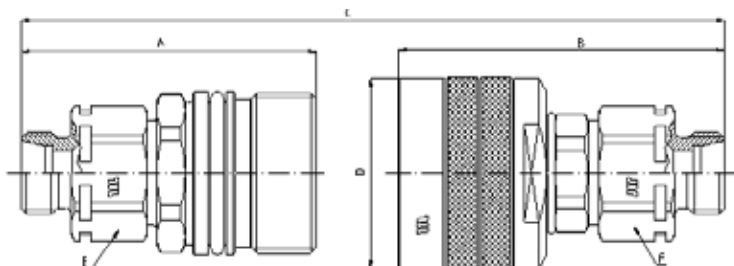

**Q05211120A**

**Q05111120A**

**METRIC TERMINATION END**

**TO ISO 8434-1**

**S SERIES**

SIZE			PART NUMBER		THREAD	DIMENSIONS mm							
DN	inch	Size	Female coupling	Male coupling		A	B	C	D	E	F		
6.3	1/4"	-04	Q05211120A-04-16	Q05111120A-04-16	M16x1,5	61.5	65.5	A+B-24,5	ø30	19	19		
10	3/8"	-06	Q05211120A-06-16	Q05111120A-06-16	M16x1,5	67	73	A+B-26,5	ø34	22	22		
			Q05211120A-06-18	Q05111120A-06-18	M18x1,5	67	73	A+B-26,5	ø34	22	22		
12.5	1/2"	-08	Q05211120A-08-18	Q05111120A-08-18	M18x1,5	66.5	74.5	A+B-26,5	ø42	27	27		
			Q05211120A-08-20	Q05111120A-08-20	M20x1,5	66.5	74.5	A+B-26,5	ø42	27	27		
			Q05211120A-08-24	Q05111120A-08-24	M24x1,5	68.5	76.5	A+B-26,5	ø42	27	27		
20	3/4"	-12	Q05211120A-12-20	Q05111120A-12-20	M20x1,5	80.8	89.3	A+B-31	ø49	34	34		
			Q05211120A-12-24	Q05111120A-12-24	M24x1,5	82.8	91.3	A+B-31	ø49	34	34		
			Q05211120A-12-30	Q05111120A-12-30	M30x2	84.8	93.3	A+B-31	ø49	34	34		
25	1"	-16	Q05211120A-16-30	Q05111120A-16-30	M30x2	94,3	101.3	A+B-34,5	ø56	41	41		
			Q05211120A-16-36	Q05111120A-16-36	M36x2	96,3	103.3	A+B-34,5	ø56	41	41		
			Q05211120A-16-42	Q05111120A-16-42	M42x2	98,3	105.3	A+B-34,5	ø56	41	41		

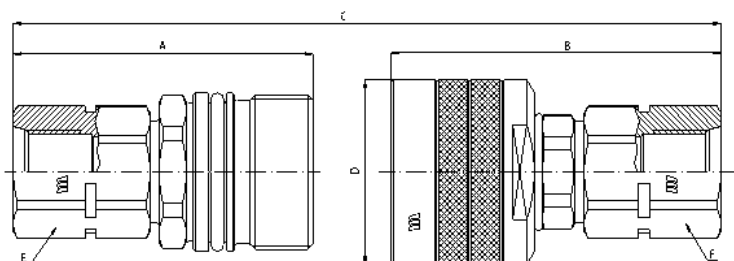

**Q05211191A**

**Q05111191A**

**METRIC TERMINATION ENDS**

**TO ISO 6149-1**

SIZE			PART NUMBER		THREAD	DIMENSIONS mm							
DN	inch	Size	Female coupling	Male coupling		A	B	C	D	E	F		
12.5	1/2"	-08	Q05211191A-08-16	Q05111191A-08-16	M16x1,5	67	75	A+B-26,5	ø42	27	27		
			Q05211191A-08-18	Q05111191A-08-18	M18x1,5	68.5	76.5	A+B-26,5	ø42	27	27		

METRIC

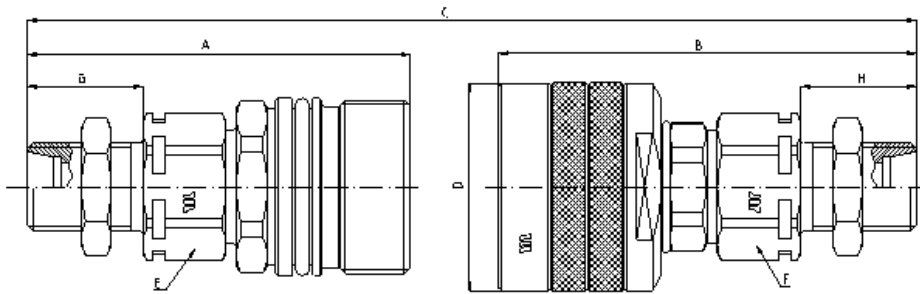

**Q05211770B**

**Q05111770B**

**METRIC TERMINATION END**

**TO ISO 8434-1**

**BULKHEAD L SERIES**

SIZE			PART NUMBER		THREAD	DIMENSIONS mm							
DN	inch	Size	Female coupling	Male coupling		A	B	C	D	E	F	G	H
6.3	1/4"	-04	Q05211770B-04-14	Q05111770B-04-14	M14x1,5	74.5	78.5	A+B-24,5	ø30	19	19	25	25
10	3/8"	-06	Q05211770B-06-12	Q05111770B-06-12	M12x1,5	81	87	A+B-26,5	ø34	22	22	25	25
			Q05211770B-06-14	Q05111770B-06-14	M14x1,5	80	86	A+B-26,5	ø34	22	22	25	25
			Q05211770B-06-16	Q05111770B-06-16	M16x1,5	80	86	A+B-26,5	ø34	22	22	26	26
			Q05211770B-06-18	Q05111770B-06-18	M18x1,5	80	86	A+B-26,5	ø34	22	22	26	26
12.5	1/2"	-08	Q05211770B-08-14	Q05111770B-08-14	M14x1,5	80.5	88.5	A+B-26,5	ø42	27	27	25	25
			Q05211770B-08-16	Q05111770B-08-16	M16x1,5	80.5	88.5	A+B-26,5	ø42	27	27	26	26
			Q05211770B-08-18	Q05111770B-08-18	M18x1,5	80.5	88.5	A+B-26,5	ø42	27	27	26	26
			Q05211770B-08-22	Q05111770B-08-22	M22x1,5	81.5	89.5	A+B-26,5	ø42	27	27	27	27
20	3/4"	-12	Q05211770B-12-18	Q05111770B-12-18	M18x1,5	94.8	103.3	A+B-31	ø49	34	34	26	26
			Q05211770B-12-22	Q05111770B-12-22	M22x1,5	95.8	104.3	A+B-31	ø49	34	34	27	27
			Q05211770B-12-26	Q05111770B-12-26	M26x1,5	96.8	105.3	A+B-31	ø49	34	34	29	29
			Q05211770B-12-30	Q05111770B-12-30	M30x2	100.8	109.3	A+B-31	ø49	34	34	32	32
25	1"	-16	Q05211770B-16-26	Q05111770B-16-26	M26x1,5	106.3	113.3	A+B-34,5	ø56	41	41	29	29
			Q05211770B-16-30	Q05111770B-16-30	M30x2	110.3	117.3	A+B-34,5	ø56	41	41	32	32
			Q05211770B-16-36	Q05111770B-16-36	M36x2	110.3	117.3	A+B-34,5	ø56	41	41	32	32

## SCREW - TERMINATION ENDS

### METRIC

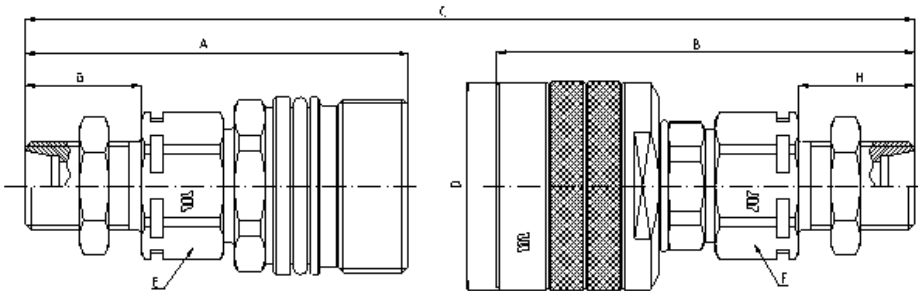

**Q05211870B**

**Q05111870B**

**METRIC TERMINATION END**

**TO ISO 8434-1**

**BULKHEAD S SERIES**

SIZE			PART NUMBER		THREAD	DIMENSIONS mm							
DN	inch	Size	Female coupling	Male coupling		A	B	C	D	E	F	G	H
10	3/8"	-06	Q05211870B-06-16	Q05111870B-06-16	M16x1,5	81	87	A+B-26,5	ø34	22	22	27	27
			Q05211870B-06-18	Q05111870B-06-18	M18x1,5	81	87	A+B-26,5	ø34	22	22	27	27
12.5	1/2"	-08	Q05211870B-08-18	Q05111870B-08-18	M18x1,5	81.5	89.5	A+B-26,5	ø42	27	27	27	27
			Q05211870B-08-20	Q05111870B-08-20	M20x1,5	81.5	89.5	A+B-26,5	ø42	27	27	27	27
			Q05211870B-08-24	Q05111870B-08-24	M24x1,5	83.5	91.5	A+B-26,5	ø42	27	27	29	29
20	3/4"	-12	Q05211870B-12-24	Q05111870B-12-24	M24x1,5	97.8	106.3	A+B-31	ø49	34	34	29	29
			Q05211870B-12-30	Q05111870B-12-30	M30x2	102.8	111.3	A+B-31	ø49	34	34	34	34
25	1"	-16	Q05211870B-16-30	Q05111870B-16-30	M30x2	112.3	119.3	A+B-34,5	ø56	41	41	34	34
			Q05211870B-16-36	Q05111870B-16-36	M36x2	114.3	121.3	A+B-34,5	ø56	41	41	36	36
			Q05211870B-16-42	Q05111870B-16-42	M42x2	116.3	123.3	A+B-34,5	ø56	41	41	40	40

### NPT

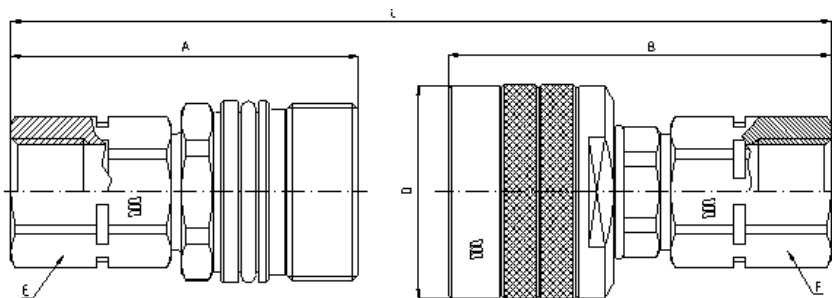

**Q05211341A**

**Q05111341A**

**NPTF TERMINATION END**

**TO ANSI B 1.20.3**

SIZE			PART NUMBER		THREAD	DIMENSIONS mm							
DN	inch	Size	Female coupling	Male coupling		A	B	C	D	E	F		
6.3	1/4"	-04	Q05211341A-04-04	Q05111341A-04-04	1/4" NPTF	61.5	65.5	A+B-24,5	ø30	19	19		
10	3/8"	-06	Q05211341A-06-06	Q05111341A-06-06	3/8" NPTF	69.5	75.5	A+B-26,5	ø34	22	22		
12.5	1/2"	-08	Q05211341A-08-08	Q05111341A-08-08	1/2" NPTF	69.5	77.5	A+B-26,5	ø42	27	27		
20	3/4"	-12	Q05211341A-12-12	Q05111341A-12-12	3/4" NPTF	82,8	91.3	A+B-31	ø49	34	34		
25	1"	-16	Q05211341A-16-16	Q05111341A-16-16	1" NPTF	95.3	102.3	A+B-34,5	ø56	41	41		

SAE

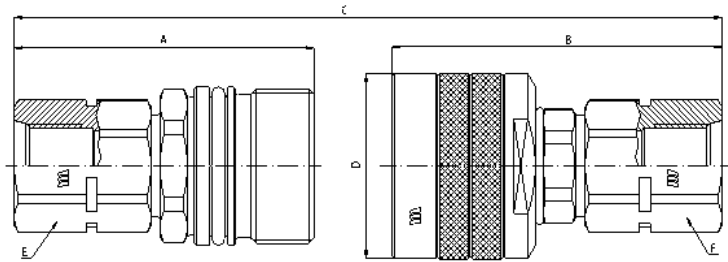

**Q05211301A**

**Q05111301A**

SAE TERMINATION END

TO SAE J1926-1

SIZE			PART NUMBER		THREAD	DIMENSIONS mm							
DN	inch	Size	Female coupling	Male coupling		A	B	C	D	E	F		
10	3/8"	-06	Q05211301A-06-06	Q05111301A-06-06	9/16"-18UNF	69.5	75.5	A+B-26,5	ø34	22	22		
12.5	1/2"	-08	Q05211301A-08-08	Q05111301A-08-08	3/4"-16 UNF	69	77	A+B-26,5	ø42	27	27		
			Q05211301A-08-10	Q05111301A-08-10	7/8"-14 UNF	71.5	79.5	A+B-26,5	ø42	27	27		

ORFS

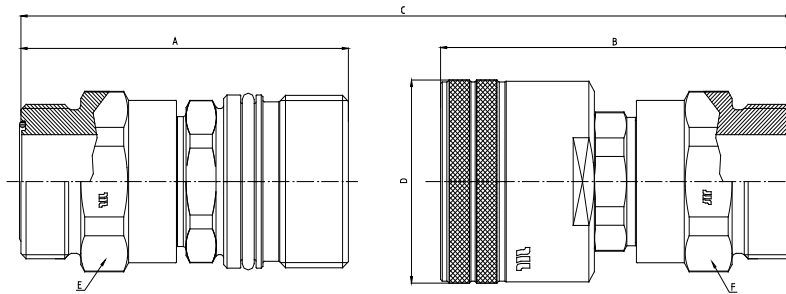

**Q05211240A**

**Q05111240A**

ORFS TERMINATION ENDS

TO ISO 8434-3

SIZE			PART NUMBER		THREAD	DIMENSIONS mm							
DN	inch	Size	Female coupling	Male coupling		A	B	C	D	E	F		
25	1"	-16	Q05211240A-16-16	Q05111240A-16-16	1.7/16"-12 UN	98.3	102.8	A+B-34,5	ø56	46	46		
25	1"	-16	Q05211240A-16-20	Q05111240A-16-20	1.11/16"-12UN	95.8	102.8	A+B-34,5	ø56	46	46		



<b>SIZE</b>	<b>WORKING PRESSURE (Dynamic)</b>	<b>RATED FLOW at 0.2 MPa of pressure drop</b>	<b>OIL SPILLAGE Connection/ Disconnection</b>	<b>MINIMUM BURST PRESSURE</b>	<b>CONNECTION/ DISCONNECTION UNDER PRESSURE</b>

mm	inch	dash	MPa	PSI	l/min	US GPM	cc.	cubic inch	Male		Female		M & F		
									MPa	PSI	MPa	PSI	MPa	PSI	
10	3/8	06	35	5075	26	6.9	1.5	0.092	150	21750	160	23200	180	26100	Allowed
12.5	1/2	08	30	4350	54	14.3	2	0.122	130	18850	140	20300	140	20300	Allowed
20	3/4	12	30	4350	107	28.3	5	0.305	130	17750	130	18850	140	20300	Allowed
25	1	16	25	3625	186	49.1	9	0.549	110	15950	110	15950	110	15950	Allowed
38	1 1/2	24	30	4350	492	130.0	25	1.526	130	18850	125	18125	130	18850	Allowed

Pressure Drop

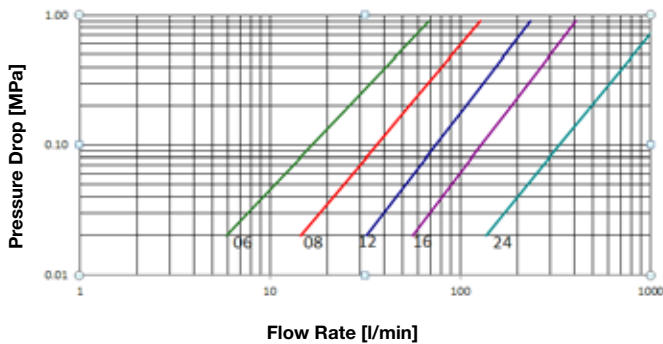

Pressure Drop

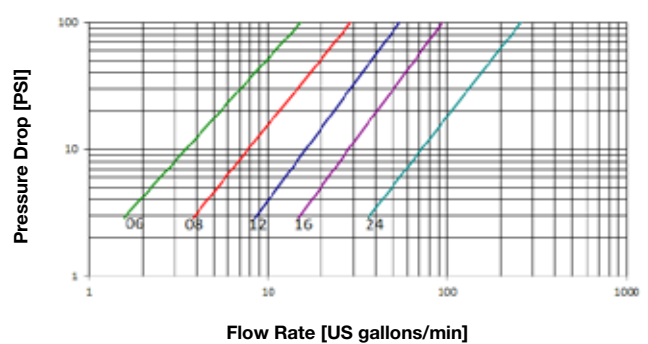

### Product description:

- Screw-type couplings specially designed for heavy duty applications such as hammers, attachments, rock crushers, etc.
- Thanks to strengthened internal components this series is highly resistant against backflow, flow impulses and peaks, pressure impulses, vibration and hose bending
- Connection and disconnection is made by screwing the sleeve, also possible with rated pressure in the line
- Connection secured on the thread between the sleeve and the male coupling
- Shut-off by poppet valve
- Hexagonal profile of external sleeve for an easy connection and disconnection in high pressure conditions
- Interchangeable with MQS-SG series and similar products available on the market

<b>Material</b>	Female and male coupling in high standard steel. Carbonitrided valve, springs in C98 steel, seals in NBR (other materials available on request) and back-up ring in PTFE
<b>Working Temperature</b>	-22°F up to +230°F (-30°C up to +110°C) Specific seals available in case of higher temperatures
<b>Safety Factor</b>	4:1 for dynamic pressures
<b>Impulse Pressures</b>	200,000 cycles at 133% of the rated one (freq. 1Hz)
<b>Test Specifications</b>	ISO 7241-2



## SCREW HEAVY DUTY - TERMINATION ENDS

BSP

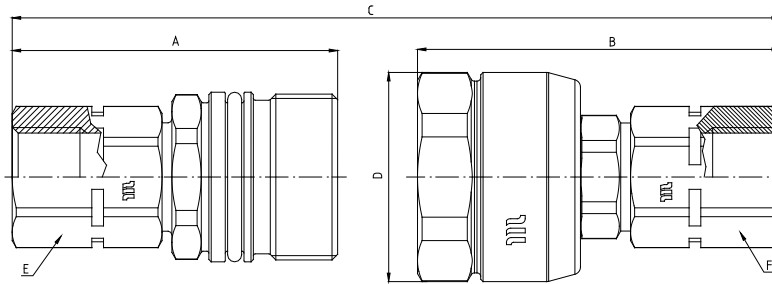

**Q06211041A**

**Q06111041A**

**BSP TERMINATION ENDS**

**TO DIN 3852 X TYPE**

SIZE			PART NUMBER		THREAD	DIMENSIONS mm							
DN	inch	Size	Female coupling	Male coupling		A	B	C	D	E	F		
10	3/8"	-06	Q06211041A-06-04	Q06111041A-06-04	1/4"	68	74	A+B-26,5	ø34,7	22	22		
			Q06211041A-06-06	Q06111041A-06-06	3/8"	69.5	75.5	A+B-26,5	ø34,7	22	22		
12.5	1/2"	-08	Q06211041A-08-06	Q06111041A-08-06	3/8"	66.5	74.5	A+B-26,5	ø44,4	27	27		
			Q06211041A-08-08	Q06111041A-08-08	1/2"	69.5	77.5	A+B-26,5	ø44,4	27	27		
20	3/4"	-12	Q06211041A-12-08	Q06111041A-12-08	1/2"	80.8	89.3	A+B-31	ø54,2	34	34		
			Q06211041A-12-12	Q06111041A-12-12	3/4"	82.8	91.3	A+B-31	ø54,2	34	34		
25	1"	-16	Q06211041A-16-12	Q06111041A-16-12	3/4"	92.3	99.3	A+B-34,5	ø59,6	41	41		
			Q06211041A-16-16	Q06111041A-16-16	1"	95.3	102.3	A+B-34,5	ø59,6	41	41		
38	1-1/2"	-24	Q06211041A-24-20	Q06111041A-24-20	1.1/4"	124.5	137.3	A+B-47,5	ø86,6	60	60		
			Q06211041A-24-24	Q06111041A-24-24	1.1/2"	127.5	140.3	A+B-47,5	ø86,6	60	60		

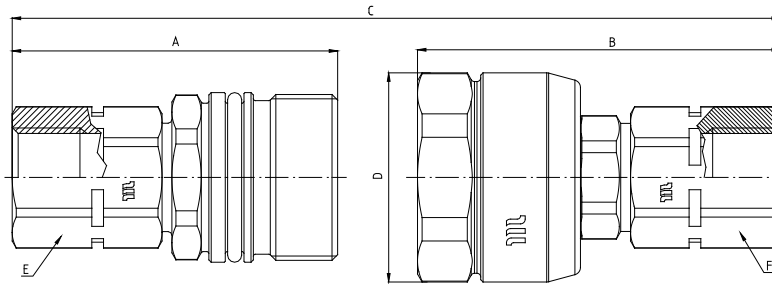

**Q06213041A**

**Q06113041A**

**BSP TERMINATION ENDS**

**TO DIN 3852 X TYPE**

SIZE			PART NUMBER		THREAD	DIMENSIONS mm							
DN	inch	Size	Female coupling	Male coupling		A	B	C	D	E	F		
12.5	1/2"	-08	Q06213041A-08-08	Q06113041A-08-08	1/2"	69.5	77.5	A+B-26,5	ø44,4	27	27		
20	3/4"	-12	Q06213041A-12-12	Q06113041A-12-12	3/4"	82.8	91.3	A+B-31	ø54,2	34	34		
25	1"	-16	Q06213041A-16-16	Q06113041A-16-16	1"	95.3	102.3	A+B-34,5	ø59,6	41	41		

### METRIC

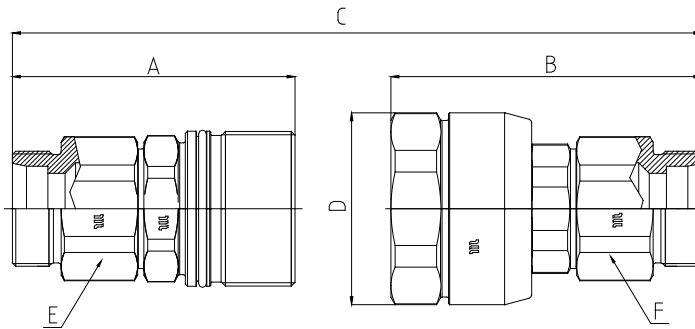

**Q0621120A**

**Q0611120A**

**METRIC TERMINATION ENDS**

**TO ISO 8434-1 S SERIES**

SIZE			PART NUMBER		THREAD	DIMENSIONS mm							
DN	inch	Size	Female coupling	Male coupling		A	B	C	D	E	F		
38	1-1/2"	-24	Q06211120A-24-52	Q06111120A-24-52	M52x2	127.6	140	A+B-47,3	ø86,6	60	60		

### ORFS

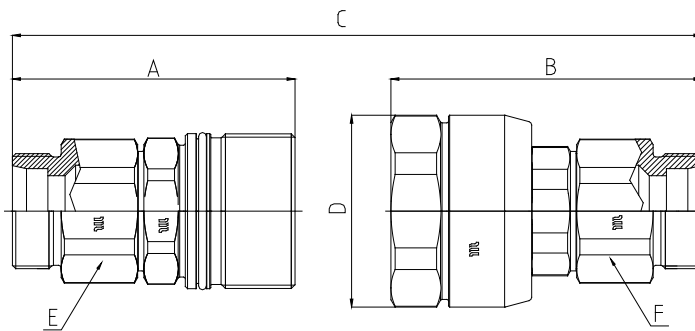

**Q06211240A**

**Q06111240A**

**ORFS TERMINATION ENDS**

**TO ISO 8434-3**

SIZE			PART NUMBER		THREAD	DIMENSIONS mm							
DN	inch	Size	Female coupling	Male coupling		A	B	C	D	E	F		
25	1"	-16	Q06211240A-16-16	Q06111240A-16-16	1.7/16"-12 UN	98.3	102.8	A+B-34,5	ø59,6	46	46		





<b>SIZE</b>	<b>WORKING PRESSURE (Dynamic)</b>	<b>RATED FLOW at 0.2 MPa of pressure drop</b>	<b>OIL SPILLAGE Connection/ Disconnection</b>	<b>MINIMUM BURST PRESSURE</b>	<b>CONNECTION/ DISCONNECTION UNDER PRESSURE</b>

mm	inch	dash	MPa	PSI	l/min	US GPM	cc.	cubic inch	Male		Female		M & F		
									MPa	PSI	MPa	PSI	MPa	PSI	
6	¼	04	70	10150	10	2.6	0.4	0.024	290	42050	350	50750	300	43500	Allowed up to 30 MPa
10	¾	06	60	8700	31	8.2	1.5	0.092	250	36250	330	47850	320	46400	Allowed up to 30 MPa
12.5	½	08	50	7250	51	13.5	2.2	0.134	200	29000	260	37700	310	44950	Allowed up to 30 MPa
20	¾	12	50	7250	102	26.9	4	0.244	200	29000	250	36250	310	44950	Allowed up to 30 MPa
25	1	16	50	7250	170	44.9	7.5	0.458	200	29000	230	33350	270	39150	Allowed up to 30 MPa
31	1¼	20	40	5800	325	85.9	15	0.916	160	23200	170	24650	230	33350	Allowed up to 15 MPa
38	1½	24	32	4640	494	130.5	23	1.404	130	18850	140	20300	150	21750	Allowed up to 15 MPa

Pressure Drop

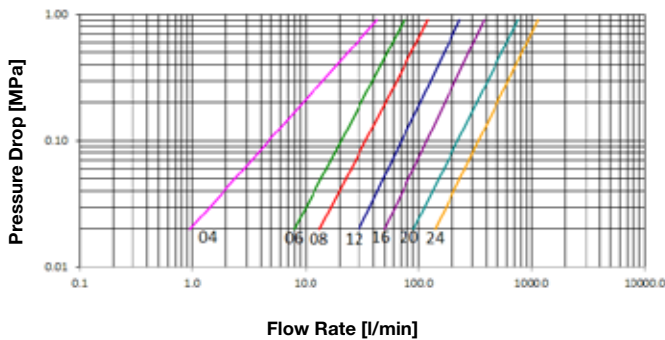

Pressure Drop

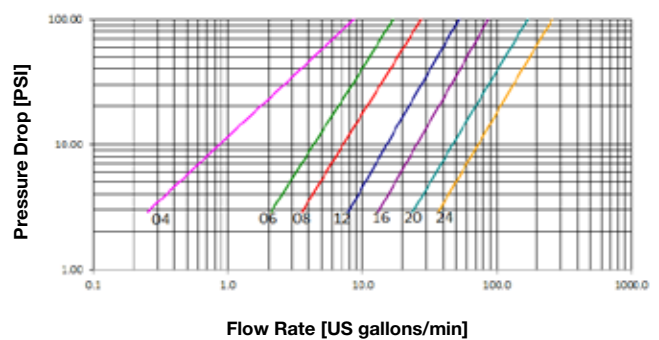

### Product description:

- Screw-on connection/disconnection system
- Sleeve with hexagon area internal components reinforced, made in steel
- Hardened valve bodies
- Three-part poppet valve with a moulded shaped seal
- Mechanical backstop to prevent partial enclosures of valves due to peaks and reverse flow
- Interchangeable with other products and widely used on the market
- Accessories (plugs and caps) and spare part kits available
- Wide range of termination ends

<b>Material</b>	Couplings in steel with some stressed area hardened. Carbonitrided valve, springs in C98 steel, seals in NBR and back-up ring in PTFE
<b>Working Temperature</b>	-22°F up to +230°F (-30°C up to +110°C)
<b>Safety Factor</b>	4:1 for dynamic pressures
<b>Impulse Pressures</b>	500,000 cycles (connected and disconnected conditions) at 120% of the rated one (freq. 1Hz)
<b>Test Specifications</b>	ISO 7241-2



## SCREW HEAVY DUTY - TERMINATION ENDS

BSP

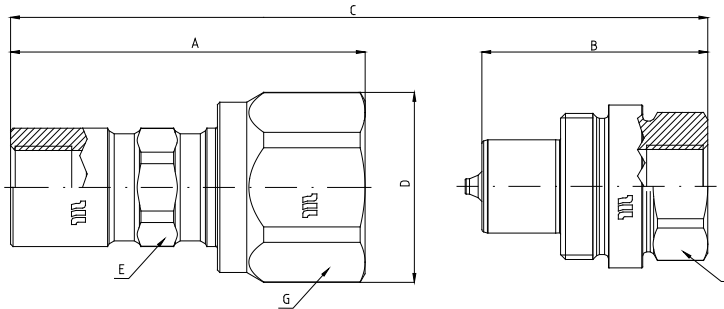

**Q05411041A**

**Q05311041A**

**BSP TERMINATION ENDS**

**TO DIN 3852 X TYPE**

SIZE			PART NUMBER		THREAD	DIMENSIONS mm						
DN	inch	Size	Female coupling	Male coupling		A	B	C	D	E	F	G
6.3	1/4"	-04	Q05411041A-04-04	Q05311041A-04-04	1/4"	63	42.2	A+B-20,8	ø35	19	22	32
10	3/8"	-06	Q05411041A-06-06	Q05311041A-06-06	3/8"	72.5	46.2	A+B-25,9	ø38,5	22	27	35
12.5	1/2"	-08	Q05411041A-08-08	Q05311041A-08-08	1/2"	82.1	54.4	A+B-27,3	ø45	27	32	41
20	3/4"	-12	Q05411041A-12-12	Q05311041A-12-12	3/4"	93.7	61.4	A+B-31,9	ø55	35	41	50
25	1"	-16	Q05411041A-16-16	Q05311041A-16-16	1"	105.8	68.3	A+B-37	ø66	41	50	60
31.5	1.1/4"	-20	Q05411041A-20-20	Q05311041A-20-20	1.1/4"	131.9	82	A+B-53,9	ø88	55	70	80
38	1 1/2"	-24	Q05411041A-24-24	Q05311041A-24-24	1.1/2"	158.9	102	A+B-70,4	ø99	60	80	90

NPT

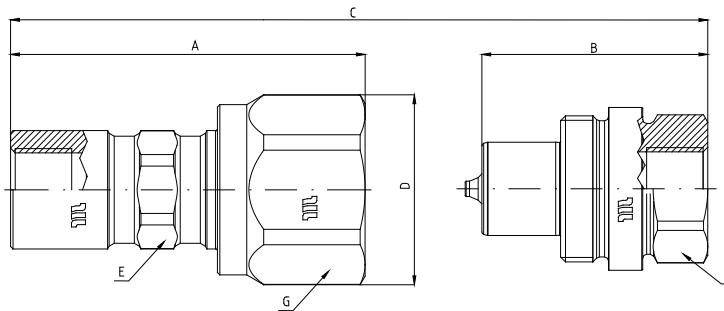

**Q05411341A**

**Q05311341A**

**NPTF TERMINATION END**

**TO ANSI B 1.20.3**

SIZE			PART NUMBER		THREAD	DIMENSIONS mm						
DN	inch	Size	Female coupling	Male coupling		A	B	C	D	E	F	G
6.3	1/4"	-04	Q05411341A-04-04	Q05311341A-04-04	1/4" NPTF	63	42.2	A+B-20,8	ø35	19	22	32
10	3/8"	-06	Q05411341A-06-06	Q05311341A-06-06	3/8" NPTF	72.5	46.2	A+B-25,9	ø38,5	22	27	35
12.5	1/2"	-08	Q05411341A-08-08	Q05311341A-08-08	1/2" NPTF	82.1	54.4	A+B-27,3	ø45	27	32	41
20	3/4"	-12	Q05411341A-12-12	Q05311341A-12-12	3/4" NPTF	93.7	61.4	A+B-31,9	ø55	35	41	50
25	1"	-16	Q05411341A-16-16	Q05311341A-16-16	1" NPTF	105.8	68.3	A+B-37	ø66	41	50	60
31.5	1.1/4"	-20	Q05411341A-20-20	Q05311341A-20-20	1.1/4" NPTF	131.9	82	A+B-53,9	ø88	55	70	80
38	1 1/2"	-24	Q05411341A-24-24	Q05311341A-24-24	1.1/2" NPTF	158.9	102	A+B-70,4	ø99	60	80	90





## SCREW HYDRAULIC CYLINDERS (POPPET)

<b>SIZE</b>	<b>WORKING PRESSURE (Dynamic)</b>	<b>RATED FLOW at 0.2 MPa of pressure drop</b>	<b>OIL SPILLAGE Connection/ Disconnection</b>	<b>MINIMUM BURST PRESSURE</b>	<b>CONNECTION/ DISCONNECTION UNDER PRESSURE</b>

mm	inch	dash	MPa	PSI	l/min	US GPM	cc.	cubic inch	Male		Female		M & F		
									MPa	PSI	MPa	PSI	MPa	PSI	
6.3	1/4	04	70	10150	11	2.9	0.4	0.024	350	50750	310	44950	320	46400	Residual pressure
10	3/8	06	70	10150	26	7	0.6	0.037	280	40600	300	43500	280	40600	Residual pressure

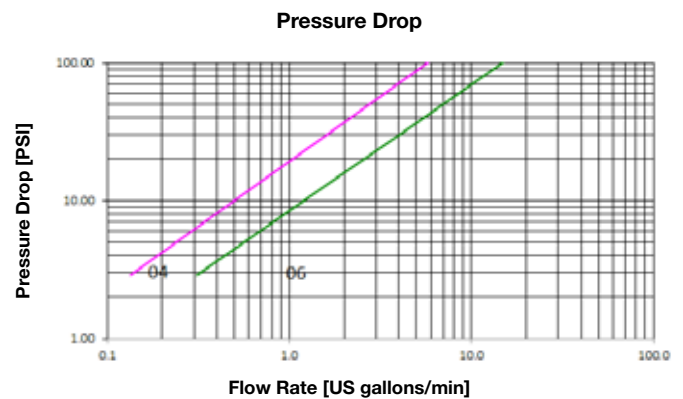
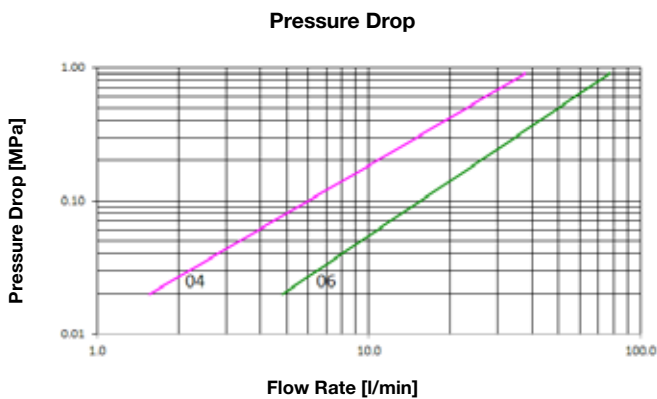

### Product description:

- Screw-type couplings specially designed for very high pressure applications on cylinders and hydraulic rams
- Connection and disconnection is made by screwing the sleeve and can be made with residual pressure in the line
- Connection secured on the thread between the sleeve and the male coupling
- Shut-off by poppet valve provides effective hydraulic sealing
- Interchangeable with other products and widely used in the USA and Europe
- ISO 14540 compliant

<b>Material</b>	Female and male coupling in steel. Carbonitrided valve, springs in C98 steel, seals in NBR (other materials available on request) and back-up ring in PTFE
<b>Working Temperature</b>	-22°F up to +230°F (-30°C up to +110°C) Specific seals available in case of higher temperatures
<b>Safety Factor</b>	4:1 for dynamic pressures
<b>Impulse Pressures</b>	50,000 cycles at 133% of the rated one (freq. 1Hz)
<b>Test Specifications</b>	ISO 7241-2



## SCREW HYDRAULIC CYLINDERS (POPPET) - TERMINATION ENDS

NPT

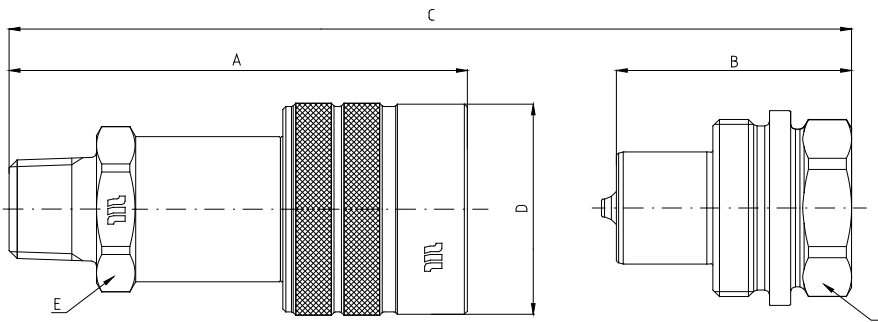

### Q05611280B

NPT TERMINATION ENDS

TO ANSI B1.20.3

SIZE			PART NUMBER		THREAD	DIMENSIONS mm							
DN	inch	Size	Female coupling	Male coupling		A	B	C	D	E	F		
6.3	1/4"	-04	Q05611280B-04-04	-	1/4" NPTF	62.4	-	A+B-19	ø30	21	-		
10	3/8"	-06	Q05611280B-06-04	-	1/4" NPTF	76	-	A+B-25	ø35,6	25	-		
			Q05611280B-06-06	-	3/8" NPTF	76	-	A+B-25	ø35,6	25	-		

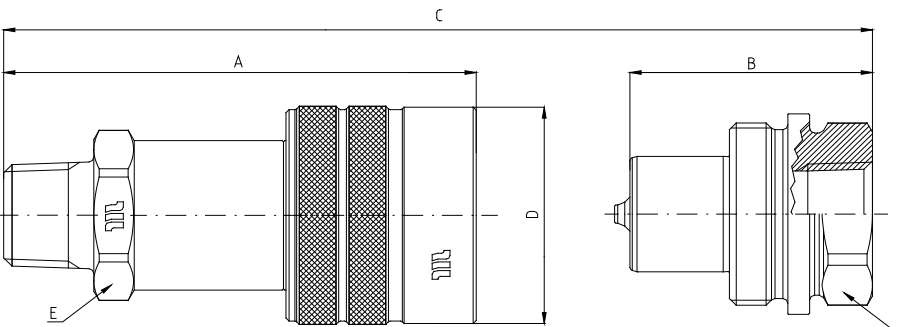

### Q05511341B

NPT TERMINATION ENDS

TO ANSI B1.20.3

SIZE			PART NUMBER		THREAD	DIMENSIONS mm							
DN	inch	Size	Female coupling	Male coupling		A	B	C	D	E	F		
6.3	1/4"	-04	-	Q05511341B-04-04	1/4" NPTF	-	34	A+B-19	-	-	22		
10	3/8"	-06	-	Q05511341B-06-04	1/4" NPTF	-	39	A+B-25	-	-	27		
			-	Q05511341B-06-06	3/8" NPTF	-	39	A+B-25	-	-	27		







## SCREW HYDRAULIC CYLINDERS (BALL) - TERMINATION ENDS

<b>SIZE</b>	<b>WORKING PRESSURE (Dynamic)</b>	<b>RATED FLOW at 0.2 MPa of pressure drop</b>	<b>OIL SPILLAGE Connection/ Disconnection</b>	<b>MINIMUM BURST PRESSURE</b>	<b>CONNECTION/ DISCONNECTION UNDER PRESSURE</b>

mm	inch	dash	MPa	PSI	l/min	US GPM	cc.	cubic inch	Male		Female		M & F		
									MPa	PSI	MPa	PSI	MPa	PSI	
6.3	1/4	04	70	10150	6	1.6	0.3	0.018	180	26100	170	24650	320	46400	Residual pressure
10	3/8	06	70	10150	15	4	0.5	0.031	170	24650	180	26100	280	40600	Residual pressure

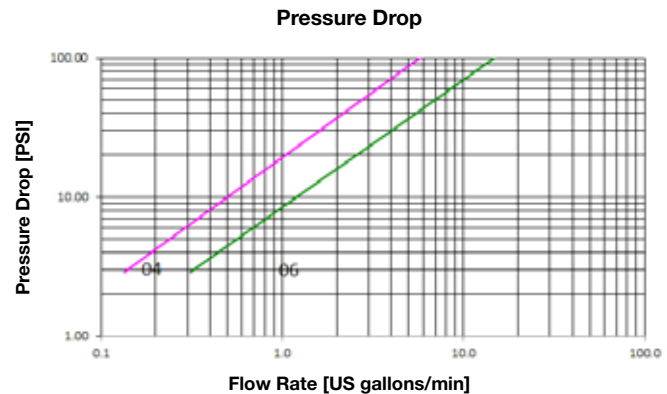
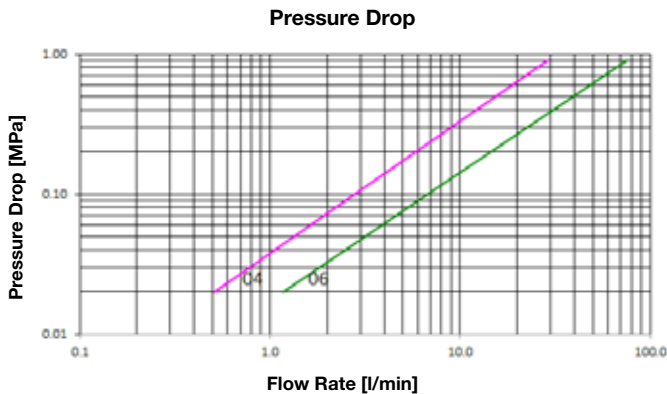

### Product description:

- Screw-type couplings specially designed for very high pressure applications on cylinders and hydraulic rams
- Connection and disconnection is made by screwing the sleeve and can be made with residual pressure in the line
- Connection secured on the thread between the sleeve and the male coupling
- Shut-off by ball valve provides effective hydraulic sealing
- Interchangeable with other products and widely used in the USA and Europe
- ISO 14540 compliant

<b>Material</b>	Female and male coupling in steel. Carbonitrided valve, springs in C98 steel, seals in NBR (other materials available on request) and back-up ring in PTFE
<b>Working Temperature</b>	-22°F up to +230°F (-30°C up to +110°C) Specific seals available in case of higher temperatures
<b>Safety Factor</b>	4:1 for dynamic pressures
<b>Impulse Pressures</b>	50,000 cycles at 133% of the rated one (freq. 1Hz)
<b>Test Specifications</b>	ISO 7241-2



## SCREW HYDRAULIC CYLINDERS (BALL) - TERMINATION ENDS

NPT

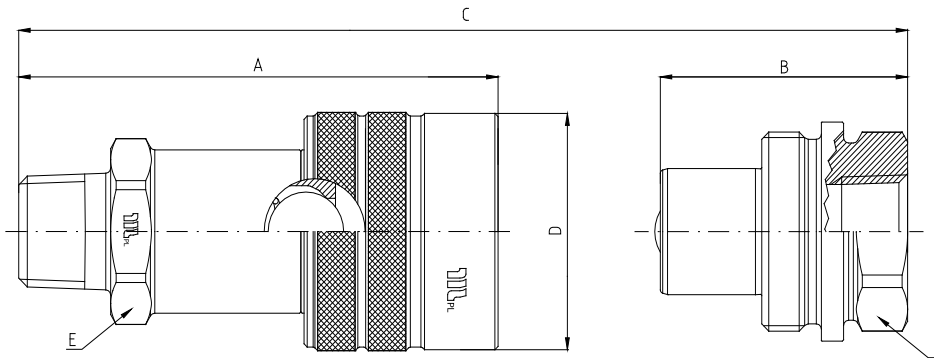

**Q05611280C**  
NPT TERMINATION ENDS  
TO ANSI B1.20.3

SIZE			PART NUMBER		THREAD	DIMENSIONS mm							
DN	inch	Size	Female coupling	Male coupling		A	B	C	D	E	F		
6.3	1/4"	-04	Q05611280C-04-04		1/4" NPTF	62.4	-	A+B-19	ø30	21			
10	3/8"	-06	Q05611280C-06-04	-	1/4" NPTF	75.6	-	A+B-25	ø35,6	25	-		
			Q05611280C-06-06	-	3/8" NPTF	75.6	-	A+B-25	ø35,6	25	-		

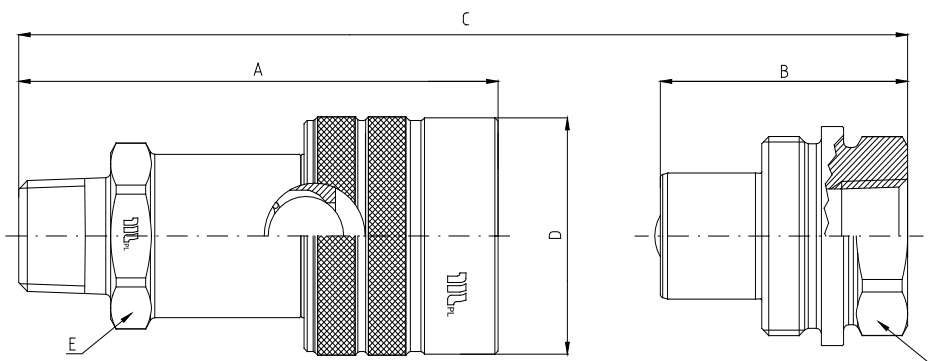

**Q05510341C**  
NPT TERMINATION ENDS  
TO ANSI B1.20.3

SIZE			PART NUMBER		THREAD	DIMENSIONS mm							
DN	inch	Size	Female coupling	Male coupling		A	B	C	D	E	F		
6.3	1/4"	-04	-	Q05510341C-04-04	1/4" NPTF	-	32	A+B-19	-	-	22		
10	3/8"	-06	-	Q05510341C-06-04	1/4" NPTF	-	39	A+B-25	-	-	27		
			-	Q05510341C-06-06	3/8" NPTF	-	39	A+B-25	-	-	27		

Q.SAFE Q 26-5





<b>SIZE</b>	<b>WORKING PRESSURE (Dynamic)</b>	<b>RATED FLOW at 0.2 MPa of pressure drop</b>	<b>OIL SPILLAGE Connection/ Disconnection</b>	<b>MINIMUM BURST PRESSURE</b>	<b>CONNECTION/ DISCONNECTION UNDER PRESSURE</b>

mm	inch	dash	MPa	PSI	l/min	US GPM	cc.	cubic inch	Male		Female		M & F		
									MPa	PSI	MPa	PSI	MPa	PSI	
20	¾	12	25	3625	92	24.3	7.5	0.458	100	14500	120	17400	110	15950	Residual pressure
25	1	16	25	3625	121	32.0	9	0.549	120	17400	140	20300	130	18850	Residual pressure

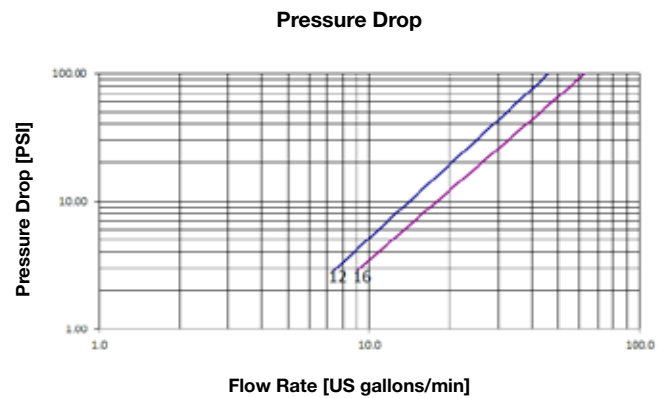
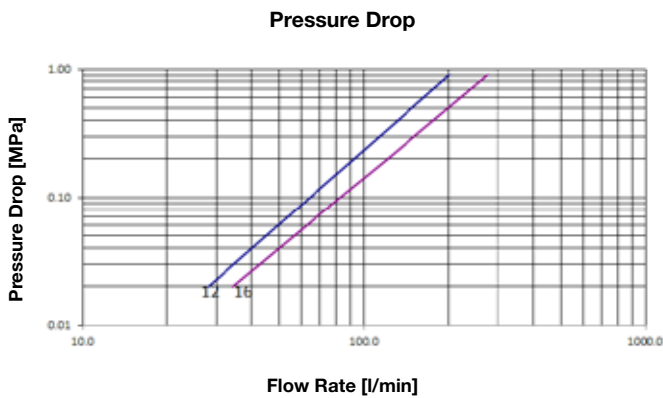

### Product description:

- Screw-type couplings specially designed for truck trailer applications
- Wing Nut shaped sleeve for easier connection and disconnection by hand, also in case of residual pressure in the line
- Connection secured on the thread between the sleeve and the female coupling
- Shut-off by poppet valve
- Interchangeable with similar products available on the market

<b>Material</b>	Female and male coupling in steel. Carbonitrided valve, springs in C98 steel, seals in NBR (other materials available on request) and back-up ring in PTFE
<b>Working Temperature</b>	-22°F up to +230°F (-30°C up to +110°C)
<b>Safety Factor</b>	4:1 for dynamic pressures and 1:2 for static pressures
<b>Test Specifications</b>	ISO 7241-2



## SCREW FOR TRUCK - TERMINATION ENDS

BSP

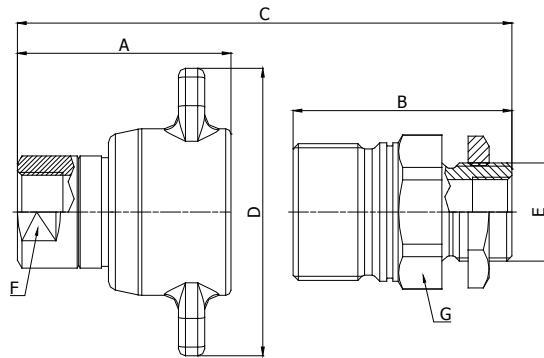

**Q05811041A**

**Q05711041A**

**BSP TERMINATION ENDS**

**TO DIN 3852 X TYPE**

SIZE			PART NUMBER		THREAD	DIMENSIONS mm						
DN	inch	Size	Female coupling	Male coupling		A	B	C	D	E	F	G
20	3/4"	-12	Q05811041A-12-12	Q05711041A-12-12	3/4"	78	78	138	117	1.1/4"	33	46
25	1"	-16	Q05811041A-16-16	Q05711041A-16-16	1"	83	83	148	117	1.1/4"	40	55







<b>SIZE</b>	<b>WORKING PRESSURE (Dynamic)</b>	<b>RATED FLOW at 0.2 MPa of pressure drop</b>	<b>CONNECTION EFFORT</b>	<b>OIL SPILLAGE Connection/ Disconnection</b>	<b>MINIMUM BURST PRESSURE</b>	<b>CONNECTION/ DISCONNECTION UNDER PRESSURE</b>

mm	inch	dash	MPa	PSI	l/min	US GPM	N	lb.	cc.	cubic inch	Male		Female		M & F		
											MPa	PSI	MPa	PSI	MPa	PSI	
5	1/8	02	40	5800	2	0.6	28	6.3	0.5	0.031	210	30450	280	40600	160	23200	Not allowed
6.3	1/4	04	35	5075	8	2.2	36	8.1	0.8	0.049	150	21750	220	31900	230	33350	Not allowed
10	3/8	06	30	4350	34	9.1	38	8.5	1.5	0.092	130	18850	160	23200	180	26100	Not allowed
12.5	1/2	08	30	4350	55	14.6	50	11.2	2.5	0.153	120	17400	130	18850	140	20300	Not allowed
20	3/4	12	25	3625	122	32.1	56	12.6	8.5	0.519	110	15950	110	15950	130	18850	Not allowed
25	1	16	25	3625	183	48.3	56	12.6	15.0	0.915	110	15950	110	15950	100	14500	Not allowed

Pressure Drop

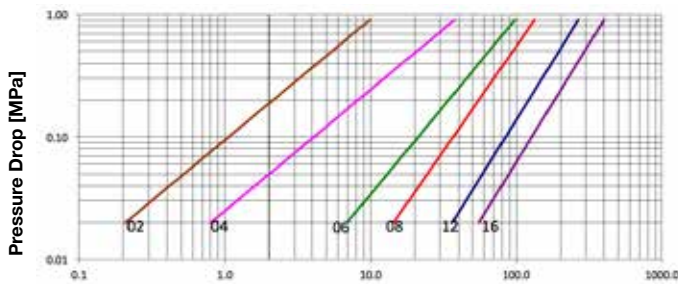

Flow Rate [l/min]

Pressure Drop

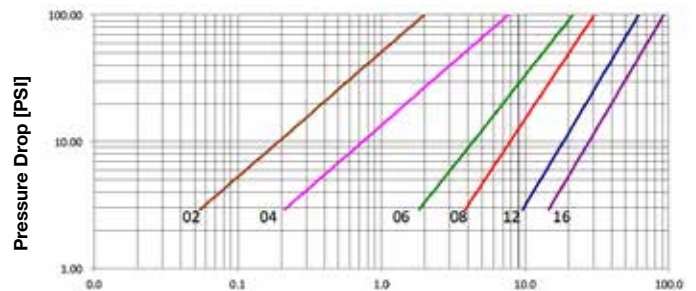

Flow Rate [US gallons/min]

### Product description:

- Reference series for all industrial applications
- Simple connection and disconnection by pulling back the sleeve
- Positive, quick connection of the male into the female by latching the ball system
- Shut-off by poppet valve
- High resistant materials
- Interchangeable according to ISO 7241-1 series B
- FKM (VITON) seal

<b>Material</b>	Female and male in AISI 316 steel. Couplings in high grade carbon steel hardened. Springs in C98 steel, seals in FKM (VITON) (other materials on request) and back-up ring in PTFE
<b>Working Temperature</b>	-25°C up to +200°C For other temperatures, the quick coupling is assembled with specific seals
<b>Safety Factor</b>	4:1 for dynamic pressures
<b>Impulse Pressures</b>	Withstands 100,000 cycles of impulse pressure at 133% of the rated one (freq. 1Hz)
<b>Test Specifications</b>	ISO 7241-2



**BSP**

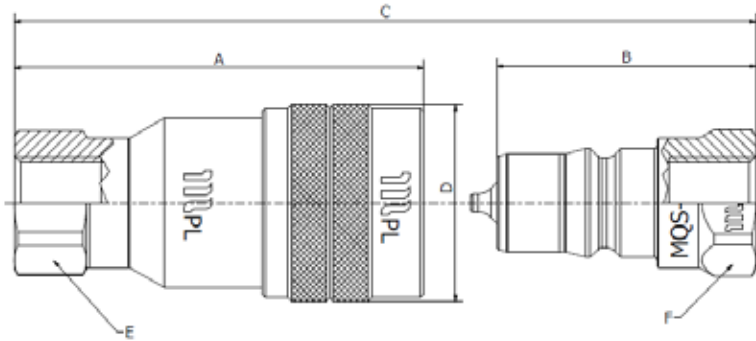

**Q02423041A**

**Q02123041A**

**BSP TERMINATION ENDS**

**TO DIN 3852 X TYPE**

**FKM (VITON) SEAL**

SIZE			PART NUMBER		THREAD	DIMENSIONS mm					
DN	inch	Size	Female coupling	Male coupling		A	B	C	D	E	F
6.3	1/4"	-04	Q02423041A-04-04	Q02123041A-04-04	1/4"	58.8	37.2	A+B-21,6	ø28	19	19
10	3/8"	-06	Q02423041A-06-06	Q02123041A-06-06	3/8"	66.2	41.5	A+B-24,7	ø35	24	22
12.5	1/2"	-08	Q02423041A-08-08	Q02123041A-08-08	1/2"	74	46.5	A+B-27,5	ø42	30	27
20	3/4"	-12	Q02423041A-12-12	Q02123041A-12-12	3/4"	91	56.5	A+B-34,5	ø52	36	36
25	1"	-16	Q02423041A-16-16	Q02123041A-16-16	1"	104	64.5	A+B-39,5	ø60	41	41

**NPT**

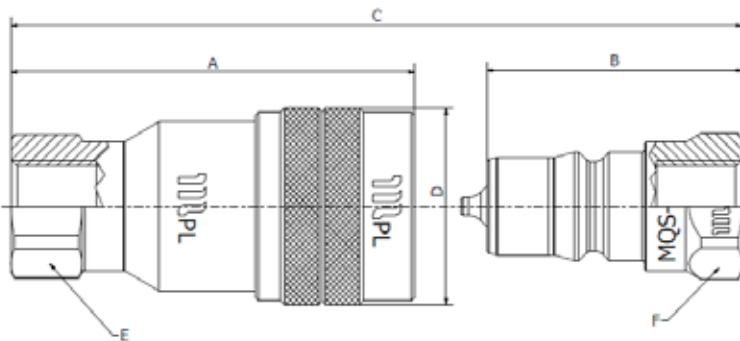

**Q02423341A**

**Q02123341A**

**NPTF TERMINATION END**

**TO ANSI B 1.20.3**

**FKM (VITON) SEAL**

SIZE			PART NUMBER		THREAD	DIMENSIONS mm					
DN	inch	Size	Female coupling	Male coupling		A	B	C	D	E	F
5	1/8"	-02	Q02423341A-02-02	Q02123341A-02-02	1/8" NPTF	48.5	30	A+B-18,5	ø22	15	14
6.3	1/4"	-04	Q02423341A-04-04	Q02123341A-04-04	1/4" NPTF	58.8	37.2	A+B-21,6	ø28	19	19
10	3/8"	-06	Q02423341A-06-06	Q02123341A-06-06	3/8" NPTF	66.2	41.5	A+B-24,7	ø35	24	22
12.5	1/2"	-08	Q02423341A-08-08	Q02123341A-08-08	1/2" NPTF	74	46.5	A+B-27,5	ø42	30	27
20	3/4"	-12	Q02423341A-12-12	Q02123341A-12-12	3/4" NPTF	91	56.5	A+B-34,5	ø52	36	36
25	1"	-16	Q02423341A-16-16	Q02123341A-16-16	1" NPTF	104	64.5	A+B-39,5	ø60	41	41





	<b>MPa</b>		<b>N</b>				
<b>SIZE</b>	<b>WORKING PRESSURE - CONNECTED (Dynamic)</b>	<b>WORKING PRESSURE - DISCONNECTED (Dynamic)</b>	<b>RATED FLOW at 0.2 MPa of pressure drop</b>	<b>CONNECTION EFFORT</b>	<b>OIL SPILLAGE Connection/ Disconnection</b>	<b>MINIMUM BURST PRESSURE</b>	<b>CONNECTION/ DISCONNECTION UNDER PRESSURE</b>

mm	inch	dash	MPa		PSI		l/ min	US GPM	N	lb.	cc.	cubic inch	Male		Female		M & F		
			MPa	PSI	MPa	PSI							MPa	PSI	MPa	PSI			
10	3/8	06	25	3625	25	3625	46	12.2	130	29.2	0.007	0.0004	100	14500	100	14500	140	20300	Not allowed
12.5	1/2	08	25	3625	25	3625	82	21.7	140	31.5	0.008	0.0005	100	14500	100	14500	140	20300	Not allowed
19	3/4	12	22	3190	22	3190	150	39.6	210	47.2	0.009	0.0005	90	13050	100	14500	120	17400	Not allowed

Pressure Drop

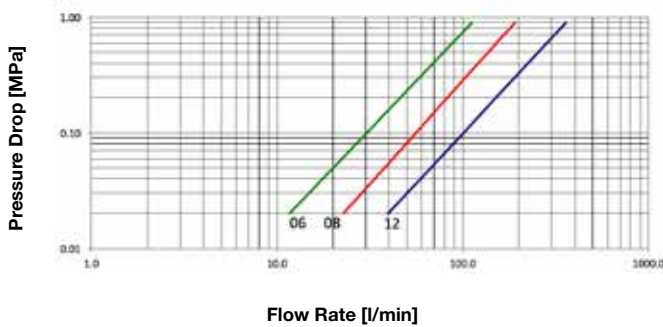

Pressure Drop

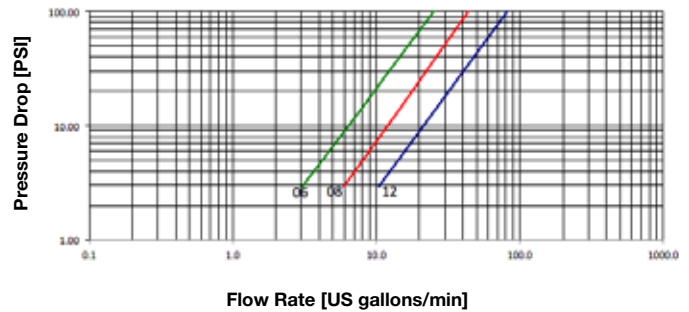

### Product description:

- Flat mating surfaces easily wiped clean to prevent contamination and spillage during connection/ disconnection
- Connection is made by pushing the male coupling and disconnection by pulling back the sleeve of the female
- Positive, quick connection of the male into the female by the latching ball system
- Shut-off by flat valve
- Interchangeability according to ISO 16028 and HTMA standards (only for 3/8")
- 1,000,000 cycles at 133% of rated (freq. 1Hz - connected conditions)
- FKM (VITON) seal

<b>Material</b>	Female and male coupling in steel, with some stressed tempered or carbonitrided areas. Springs in AISI and C98 steel, FKM (VITON) seal. Other materials (VITON, EPDM or any others) on request
<b>Working Temperature</b>	-25°C up to +200°C For other temperatures the coupling is assembled with the specified seals
<b>Safety Factor</b>	4:1 for dynamic pressures
<b>Impulse Pressures</b>	100,000 cycles at 133% of the rated one (freq. 1Hz) in disconnected conditions. 1,000,000 cycles at 133% of rated one (freq. 1Hz) in connected conditions.
<b>Test Specifications</b>	ISO 16028:1997aMD.1.2006 (E) and ISO 7241-2



BSP

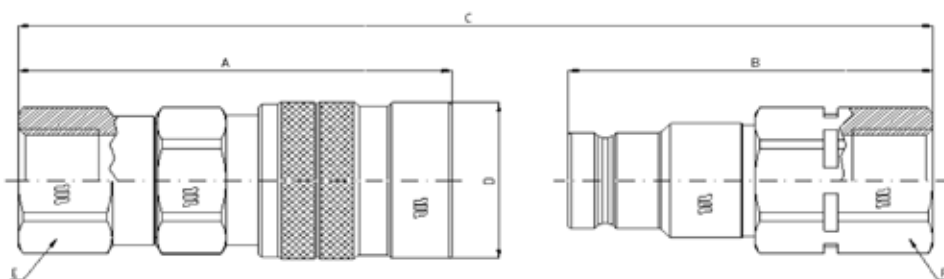

**Q04123041A**

**Q03923041A**

**BSP TERMINATION ENDS**

**TO DIN 3852 X TYPE**







**FKM (VITON) SEAL**

SIZE			PART NUMBER		THREAD	DIMENSIONS mm							
DN	inch	Size	Female coupling	Male coupling		A	B	C	D	E	F		
10	3/8"	-06	Q04123041A-06-06	Q03923041A-06-06	3/8"	74.9	62.5	A+B-15,9	ø32	27	27		
			Q04123041A-06-08	Q03923041A-06-08	1/2"	77.9	65.5	A+B-15,9	ø32	27	27		
12.5	1/2"	-08	Q04123041A-08-08	Q03923041A-08-08	1/2"	84.7	72.5	A+B-17,1	ø38	34	34		
			Q04123041A-06-12	Q03923041A-08-12	3/4"	86.7	74.5	A+B-17,1	ø38	34	34		
20	3/4"	-12	Q04123041A-12-12	Q03923041A-12-12	3/4"	105.9	88.5	A+B-21,7	ø48	41	41		
			Q04123041A-12-16	Q03923041A-12-16	1"	108.9	91.5	A+B-21,7	ø48	41	41		







					
SIZE	WORKING PRESSURE (Dynamic)	RATED FLOW at 0.2 MPa of pressure drop	OIL SPILLAGE Connection/ Disconnection	MINIMUM BURST PRESSURE	CONNECTION/ DISCONNECTION UNDER PRESSURE

mm	inch	dash	MPa	PSI	l/min	US GPM	cc.	cubic inch	Male		Female		M & F		
									MPa	PSI	MPa	PSI	MPa	PSI	
10	3/8	06	35	5075	31	8.2	1.5	0.092	150	21750	180	26100	180	26100	Not allowed
12.5	1/2	08	35	5075	51	13.5	2.2	0.134	140	20300	220	31900	250	36250	Not allowed
20	3/4	12	32	4640	92	24.3	4	0.244	130	18850	220	31900	200	29000	Not allowed
25	1	16	32	4640	156	41.2	7.5	0.458	130	18850	180	26100	180	26100	Not allowed
31	1 1/4	20	30	4350	325	85.9	15	0.916	120	17400	150	21750	160	23200	Not allowed

Pressure Drop

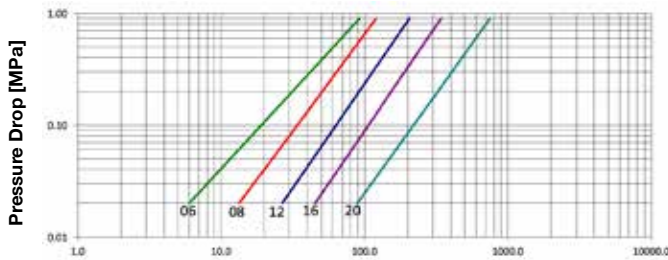

Flow Rate [l/min]

Pressure Drop

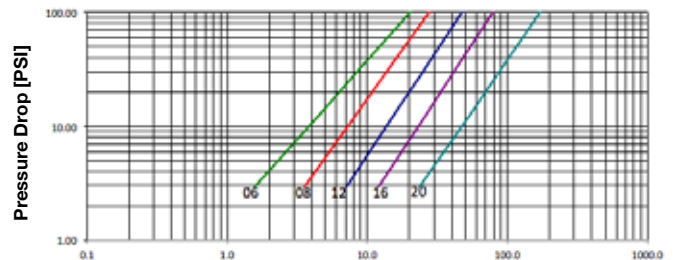

Flow Rate [US gallons/min]

### Product description:

- Screw-on connection/disconnection system
- Sleeve with hexagon area internal components reinforced, made in steel
- Hardened valve bodies
- Three-part poppet valve with a moulded shaped seal
- Mechanical backstop to prevent partial enclosures of valves due to peaks and reverse flow
- Interchangeable with other products and widely used on the market
- Accessories (plugs and caps) and spare part kits available
- Wide range of termination ends
- FKM (VITON) seal

<b>Material</b>	Couplings in steel with some stressed area hardened. Carbonitrided valve, springs in C98 steel, FKM (VITON) seal and back-up ring in PTFE
<b>Working Temperature</b>	-25°C up to +200°C
<b>Safety Factor</b>	4:1 for dynamic pressures
<b>Impulse Pressures</b>	500,000 cycles (connected and disconnected conditions) at 120% of the rated one (freq. 1Hz)
<b>Test Specifications</b>	ISO 7241-2



BSP

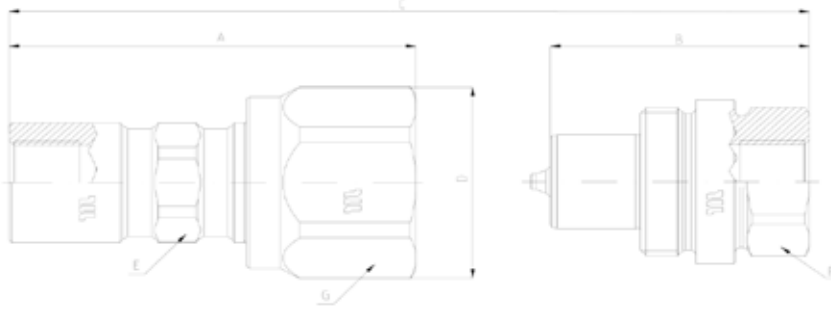

**Q05423041A**

**Q05323041A**

**BSP TERMINATION ENDS**

**TO DIN 3852 X TYPE**

**FKM (VITON) SEALS**

SIZE			PART NUMBER		THREAD	DIMENSIONS mm							
DN	inch	Size	Female coupling	Male coupling		A	B	C	D	E	F	G	
10	3/8"	-06	Q05423041A-06-06	Q05323041A-06-06	3/8"	72.5	46.2	A+B-25,9	ø38,5	22	27	35	
12.5	1/2"	-08	Q05423041A-08-08	Q05323041A-08-08	1/2"	82.1	54.4	A+B-27,3	ø45	27	32	41	
20	3/4"	-12	Q05423041A-12-12	Q05323041A-12-12	3/4"	93.7	61.4	A+B-31,9	ø55	35	41	50	
25	1"	-16	Q05423041A-16-16	Q05323041A-16-16	1"	105.8	68.3	A+B-37	ø66	41	50	60	
31.5	1.1/4"	-20	Q05423041A-20-20	Q05323041A-20-20	1.1/4"	131.9	82	A+B-53,9	ø88	55	70	80	

NPT

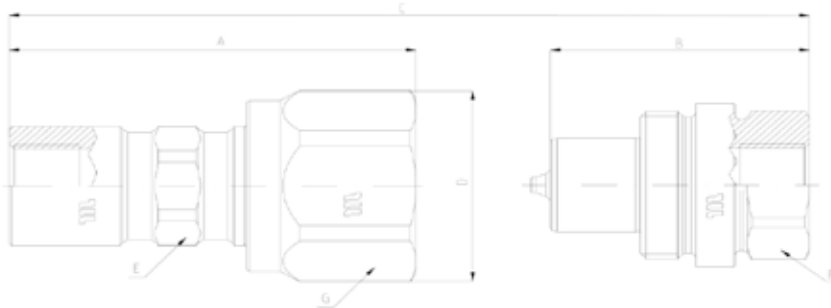

**Q05423341A**

**Q05323341A**

**NPTF TERMINATION END**

**TO ANSI B 1.20.3**

**FKM (VITON) SEALS**

SIZE			PART NUMBER		THREAD	DIMENSIONS mm							
DN	inch	Size	Female coupling	Male coupling		A	B	C	D	E	F	G	
10	3/8"	-06	Q05423341A-06-06	Q05323341A-06-06	3/8" NPTF	72.5	46.2	A+B-25,9	ø38,5	22	27	35	
12.5	1/2"	-08	Q05423341A-08-08	Q05323341A-08-08	1/2" NPTF	82.1	54.4	A+B-27,3	ø45	27	32	41	
20	3/4"	-12	Q05423341A-12-12	Q05323341A-12-12	3/4" NPTF	93.7	61.4	A+B-31,9	ø55	35	41	50	
25	1"	-16	Q05423341A-16-16	Q05323341A-16-16	1" NPTF	105.8	68.3	A+B-37	ø66	41	50	60	
31.5	1.1/4"	-20	Q05423341A-20-20	Q05323341A-20-20	1.1/4" NPTF	131.9	82	A+B-53,9	ø88	55	70	80	





# QUICK COUPLINGS

DHI



# Q.SAFE DHI

## INTRODUCTION

---

### **MQS-DHI “DIRECT HOSE INTEGRATION”**

An innovative system to enable direct assembly of the quick-release coupling to the flexible hose, and therefore avoiding intermediate connection elements.

Some of the benefits of this solution are:

- Reduced risk of oil leakage
- Elimination of unscrewing problems in the field
- Reduction in the number of assembly elements leading to reduced assembly cost, minimised risk of assembly operation mistakes and greater safety in severe working conditions, as well as easier maintenance and replacement operations

Design solutions are available for most common series ISO A, ISO B, Push-Pull & Flat-Face

**DHI quick release coupling maintenance is possible without the need to replace the flexible hose.**

# Q.SAFE DHI INDEX

QUICK COUPLINGS SERIES	FEMALE COUPLING	MALE COUPLING	SHUT-OFF SYSTEM	SPECIFICATIONS	CONNECTION	SIZE										SECTION	PAGE
						1/8"	1/4"	3/8"	1/2"	5/8"	3/4"	1"	1 1/4"	1 1/2"	2"		
MQS-DHI ISO A	Q308	Q302	Poppet Valve	ISO 7241 SERIES A	Locking Balls											Q29	1
MQS-DHI ISO A push-pull	Q313	-	Poppet Valve	ISO 7421 SERIES A	Locking Balls												5
MQS-DHI ISO B	Q324	Q321	Poppet Valve	ISO 7241 SERIES B	Locking Balls												9
MQS-DHI Flat-face	Q341	Q339	Flat Valve	ISO 16028 e HTMA	Locking Balls												13



## ISO A - TERMINATION ENDS



<b>SIZE</b>	<b>WORKING PRESSURE (Dynamic)</b>	<b>RATED FLOW at 0.2 MPa of pressure drop</b>	<b>CONNECTION EFFORT</b>	<b>OIL SPILLAGE Connection/ Disconnection</b>	<b>MINIMUM BURST PRESSURE</b>	<b>CONNECTION/ DISCONNECTION UNDER PRESSURE</b>

mm	inch	dash	MPa	PSI	l/min	US GPM	N	lb.	cc.	cubic inch	Male		Female		M & F		Not allowed
											MPa	PSI	MPa	PSI	MPa	PSI	
12.5	1/2	08	30	4350	75	19.8	80	18.0	1.8	0.110	125	18125	150	21750	150	21750	Not allowed

Pressure Drop

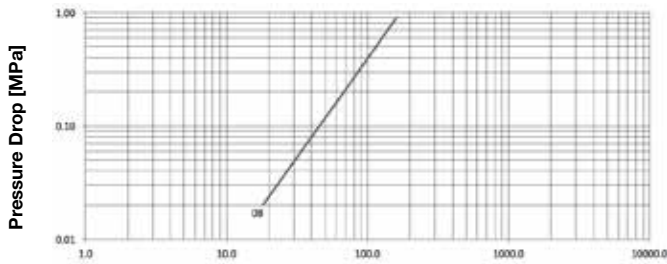

Flow Rate [l/min]

Pressure Drop

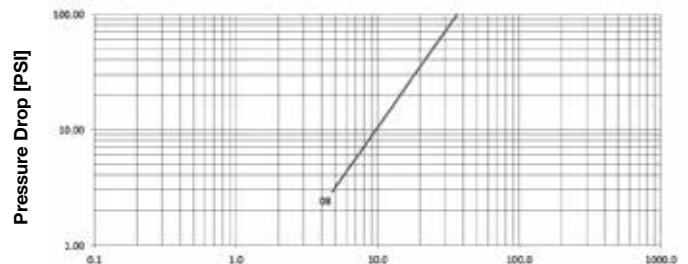

Flow Rate [US gallons/min]

### Product description:

- Dimensional and performance requirements conform to ISO 7241-1 series A, ensuring worldwide interchangeability
- Connect by pulling back the sleeve (with female ISO A)
- Positive connection by the locking ball system
- Shut-off poppet valve provides an effective hydraulic sealing
- When female bulkhead is mounted on the outside sleeve (PUSH-PULL), the coupling ensures breakaway features according to ISO 5675

<b>Material</b>	Female coupling in steel with some hardened areas, in correspondence to the most stressed points. Male couplings in high grade carbon steel. Carbonitrided valve and sleeve, springs in C98 steel, seals in NBR (other materials available on request) and back-up ring in PTFE
<b>Working Temperature</b>	-22°F up to +230°F (-30°C up to +110°C) For other temperatures, the coupling may be assembled with the specific seals
<b>Safety Factor</b>	4:1 for dynamic pressures
<b>Impulse Pressures</b>	100,000 cycles at 133% of the rated one (freq. 1Hz)
<b>Test Specifications</b>	ISO 7241-2



Quick release couplings DHI maintenance without flexible hose replacement



### Q30811MF1A

FEMALE ISO-A COUPLING  
MULTIFIT INSERT

### Q30211MF1A

MALE ISO-A COUPLING  
MULTIFIT INSERT

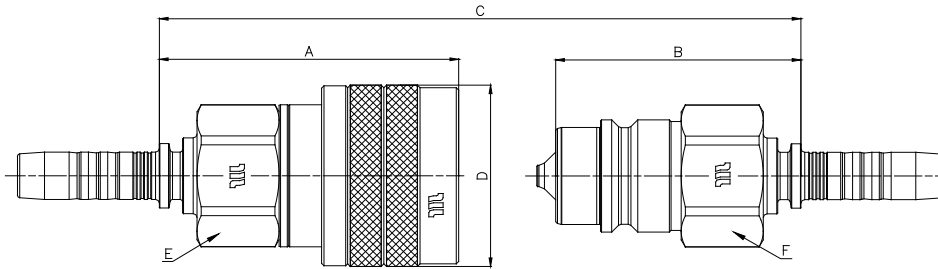

SIZE			PART NUMBER		THREAD	DIMENSIONS mm					
DN	inch	Size	Female coupling	Male coupling		A	B	C	D	E	F
12.5	1/2"	-08	Q30811MF1A-08-04	Q30211MF1A-08-04	1/4" MF2000	62.5	51.3	A+B-21,8	ø38	27	27
			Q30811MF1A-08-05	Q30211MF1A-08-05	5/16" MF2000	62	51	A+B-21,8	ø38	27	27
			Q30811MF1A-08-06	Q30211MF1A-08-06	3/8" MF2000	62	50.8	A+B-21,8	ø38	27	27
			Q30811MF1A-08-08	Q30211MF1A-08-08	1/2" MF2000	60.4	49.2	A+B-21,8	ø38	27	27



## PUSH-PULL - TERMINATION ENDS



	<b>MPa</b>		<b>N</b>			
<b>SIZE</b>	<b>WORKING PRESSURE (Dynamic)</b>	<b>RATED FLOW at 0.2 MPa of pressure drop</b>	<b>CONNECTION EFFORT</b>	<b>OIL SPILLAGE Connection/ Disconnection</b>	<b>MINIMUM BURST PRESSURE</b>	<b>CONNECTION/ DISCONNECTION UNDER PRESSURE</b>

mm	inch	dash	MPa	PSI	l/min	US GPM	N	lb.	cc.	cubic inch	Female		M & F		Not allowed
											MPa	PSI	MPa	PSI	
12.5	½	08	30	4350	68	18.0	110	244	2	0.122	140	20300	140	20300	

Pressure Drop

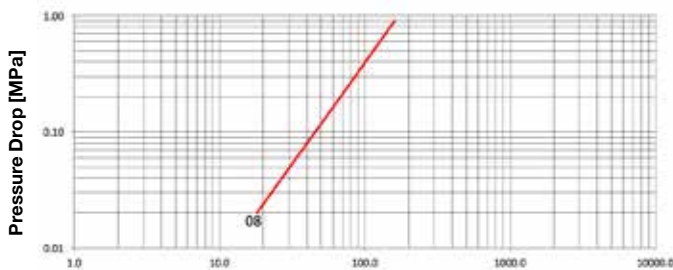

Flow Rate [l/min]

Pressure Drop

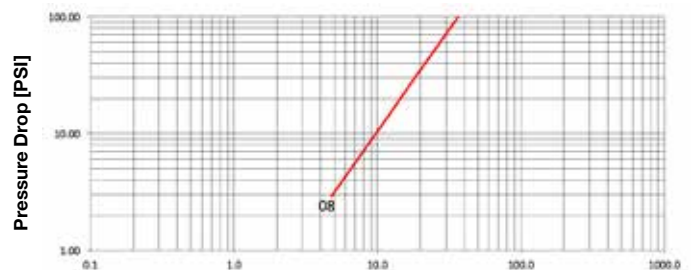

Flow Rate [US gallons/min]

### Product description:

- Female coupling designed for agriculture applications, connectable with ISO 7241-1 series A male couplings
- PUSH-PULL connection and disconnection system, in case of bulkhead mounting on the external sleeve
- Break-away function according to ISO 5675 (in case of bulkhead mounting on the external sleeve)
- Positive connection by latching balls system
- Shut-off by poppet valve
- High resistant materials
- Dimensions and performances according to ISO 7241-1 series A

<b>Material</b>	Female couplings in steel with some hardened areas, in correspondence to the most stressed points. Carbonitrided valve and sleeve, springs in C98 steel, latching balls in high resistance 100 C6 steel, seals in NBR (other materials on request) and back-up ring in PTFE
<b>Working Temperature</b>	-22°F up to +230°F (-30°C up to +110°C) For other temperatures, the coupling is assembled with specific seals
<b>Safety Factor</b>	4:1 for dynamic pressures
<b>Impulse Pressures</b>	100,000 cycles at 133% of the rated one (freq. 1Hz)
<b>Test Specifications</b>	ISO 7241-2



### Q31311MF1A

FEMALE PUSH PULL  
COUPLING

MULTIFIT INSERT

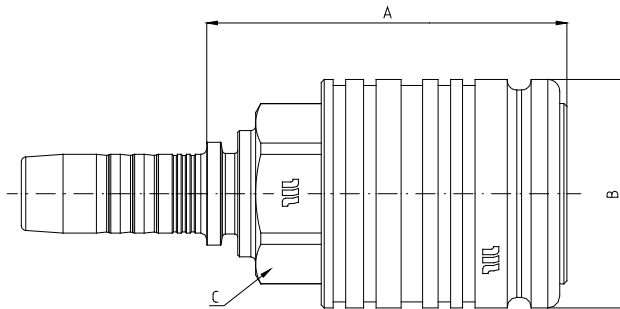

SIZE			PART NUMBER	THREAD	DIMENSIONS mm					
DN	inch	Size	Female coupling		A	B	C	D	E	F
12.5	1/2"	-08	Q31311MF1A-08-06	3/8" MF2000	62	ø38	27			
			Q31311MF1A-08-08	1/2" MF2000	60.4	ø38	27			







<b>SIZE</b>	<b>WORKING PRESSURE (Dynamic)</b>	<b>RATED FLOW at 0.2 MPa of pressure drop</b>	<b>CONNECTION EFFORT</b>	<b>OIL SPILLAGE Connection/ Disconnection</b>	<b>MINIMUM BURST PRESSURE</b>	<b>CONNECTION/ DISCONNECTION UNDER PRESSURE</b>

mm	inch	dash	MPa	PSI	l/min	US GPM	N	lb.	cc.	cubic inch	Male		Female		M & F		
											MPa	PSI	MPa	PSI	MPa	PSI	
6.3	¼	04	40	5800	16	4.3	40	9.0	0.8	0.049	180	26100	190	27550	165	23925	Not allowed
10	¾	06	35	5075	51	13.5	40	9.0	1.5	0.092	145	21025	160	23200	160	23200	Not allowed
12.5	½	08	35	5075	84	22.0	70	15.7	2.5	0.153	145	21025	145	21025	160	23200	Not allowed

Pressure Drop

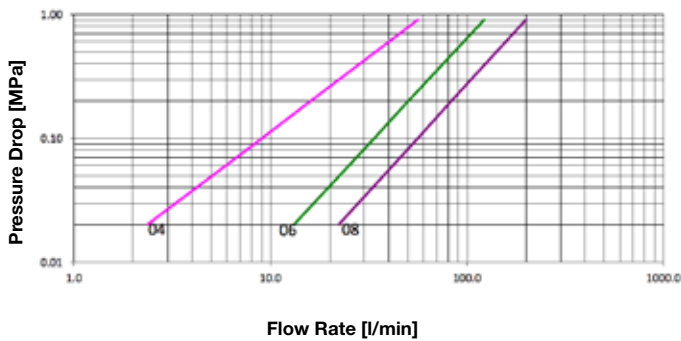

Pressure Drop

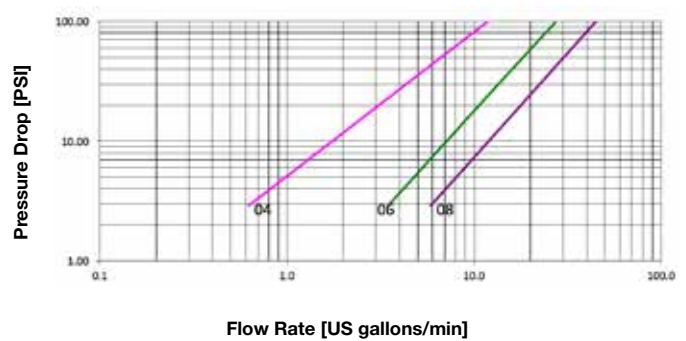

### Product description:

- Reference series for all industrial applications
- Simple connection and disconnection by pulling back the sleeve
- Positive, quick connection of the male into the female by latching the ball system
- Shut-off by poppet valve
- High resistant materials
- Interchangeable according to ISO 7241-1 series B

<b>Material</b>	Female couplings in steel, with some hardened areas, in correspondence to the most stressed points. Male couplings in high grade carbon steel hardened. Springs in C98 steel, seals in NBR (other materials on request) and back-up ring in PTFE
<b>Working Temperature</b>	-22°F up to +230°F (-30°C up to +110°C) For other temperatures, the quick coupling is assembled with specific seals
<b>Safety Factor</b>	4:1 for dynamic pressures
<b>Impulse Pressures</b>	Withstands 100,000 cycles of impulse pressure at 133% of the rated one (freq. 1Hz)
<b>Test Specifications</b>	ISO 7241-2



**Q32411MF1A**

**Q32111MF1A**

**FEMALE & MALE ISO B  
COUPLINGS**

**MULTIFIT INSERT**

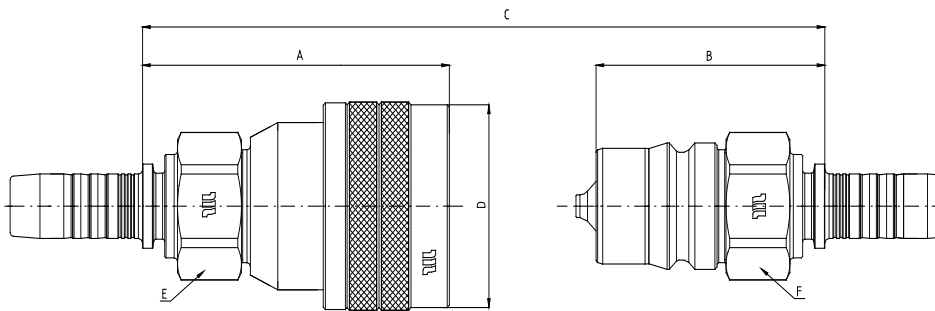

SIZE			PART NUMBER		THREAD	DIMENSIONS mm					
DN	inch	Size	Female coupling	Male coupling		A	B	C	D	E	F
6.3	1/4"	-04	Q32411MF1A-04-06	Q32111MF1A-04-06	3/8" multifit	56	45.1	A+B-21,2	ø28	19	19
10	3/8"	-06	Q32411MF1A-06-06	Q32111MF1A-06-06	3/8" multifit	65.2	51.3	A+B-24,4	ø35	22	22
12.5	1/2"	-08	Q32411MF1A-08-08	Q32111MF1A-08-08	1/2" multifit	72	53.7	A+B-27,2	ø42	27	27



## FLAT FACE - TERMINATION ENDS



	MPa		FLOW RATE →	N	OIL SPILLAGE Connection/Disconnection	MINIMUM BURST PRESSURE	CONNECTION/DISCONNECTION UNDER PRESSURE
SIZE	WORKING PRESSURE - CONNECTED (Dynamic)	WORKING PRESSURE - DISCONNECTED (Dynamic)	RATED FLOW at 0.2 MPa of pressure drop	CONNECTION EFFORT			

mm	inch	dash	MPa		PSI		l/min	US GPM	N	lb.	cc.	cubic inch	Male		Female		M & F		
			MPa	PSI	MPa	PSI							MPa	PSI	MPa	PSI			
10	3/8	06	35	5075	25	3625	53	14.0	130	29.2	0.007	0.0004	140	20300	125	18125	145	21025	Not allowed
12.5	1/2	08	35	5075	25	3625	98	25.9	140	31.5	0.008	0.0005	135	19575	115	16675	145	21025	Not allowed

Pressure Drop

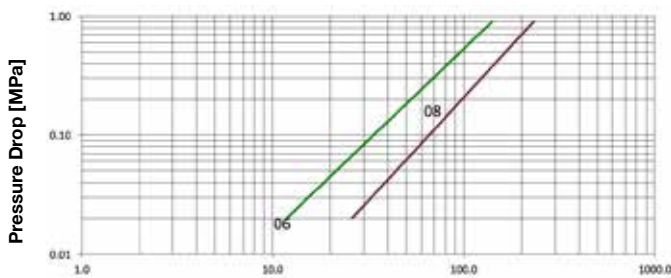

Flow Rate [l/min]

Pressure Drop

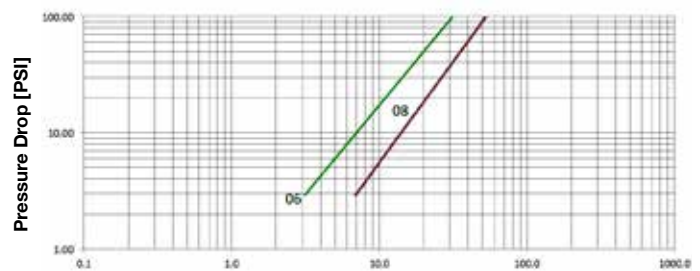

Flow Rate [US gallons/min]

### Product description:

- Connection is made by pushing the male coupling and disconnection by pulling back the sleeve of the female
- Flat mating surfaces easily wiped clean to prevent contamination and spillage during connection/disconnection
- Stainless steel springs in the female coupling
- Interchangeability according to ISO 16028 and HTMA standards

<b>Material</b>	Female and male coupling in steel, with some stressed tempered or carbonitrided areas. Springs in AISI and C98 steel, seals in polyurethane NBR. Other materials (MTON, EPDM or any others) on request.
<b>Working Temperature</b>	-22°F up to +230°F (-30°C up to +110°C) For other temperatures, the coupling may be assembled with the specific seals
<b>Safety Factor</b>	4:1 for dynamic pressures
<b>Impulse Pressures</b>	100,000 cycles at 133% of the rated one (freq. 1Hz) in disconnected conditions. 1,000,000 cycles at 133% of the rated one (freq. 1Hz) in connected conditions.
<b>Test Specifications</b>	ISO 16028:1997aMD.1.2006 (E) and ISO 7241-2



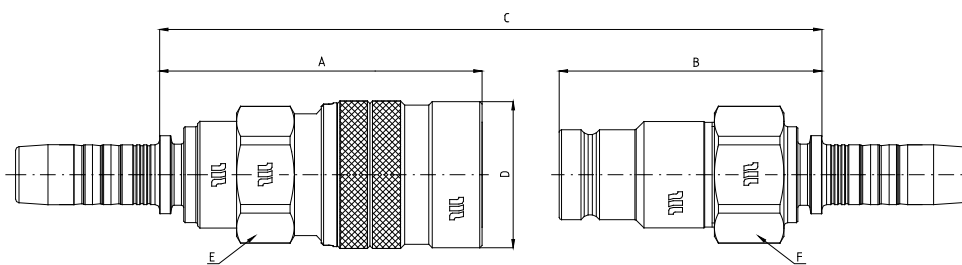

### Q34111MF1A

FEMALE FLAT FACE  
COUPLING

MULTIFIT INSERT

### Q33911MF1A

MALE FLAT FACE COUPLING

MULTIFIT INSERT

SIZE			PART NUMBER		THREAD	DIMENSIONS mm					
DN	inch	Size	Female coupling	Male coupling		A	B	C	D	E	F
10	3/8"	-06	Q34111MF1A-06-06	Q33911MF1A-06-06	3/8" MF2000	69.7	58.3	A+B-15,9	ø32	27	27
			Q34111MF1A-06-08	Q33911MF1A-06-08	1/2" MF2000	69.6	56.7	A+B-15,9	ø32	27	27
12.5	1/2"	-08	Q34111MF1A-08-08	Q33911MF1A-08-08	1/2" MF2000	78.9	66.7	A+B-17,1	ø38	34	34
			Q34111MF1A-08-12	Q33911MF1A-08-12	3/4" MF2000	75.8	65.1	A+B-17,1	ø38	34	34







# QUICK COUPLINGS

## ACCESSORIES & SPARE PARTS



# Q.SAFE ACCESSORIES INDEX

QUICK COUPLINGS SERIES	FEMALE COUPLING	MALE COUPLING	SHUT-OFF SYSTEM	SPECIFICATIONS	CONNECTION	SIZE										SECTION NUMBER		
						1/8"	1/4"	3/8"	1/2"	5/8"	3/4"	1"	1 1/4"	1 1/2"	2"			
Parking	All range	-	-	-	-													Q30
Plug and Caps	All range	-	-	-	-													Q31
Spare Parts	All range	-	-	-	-													Q32





### Q1A0114

PARKING FOR MQS-A MALE  
BULKHEAD MOUNTING

SIZE			PART NUMBER	MATERIAL	COLOUR
DN	inch	Size	Parking		
12.5	1/2"	-08	Q1A0114N-08	STEEL	-



### Q1A0104

PARKING FOR MQS-A MALE

SIZE			PART NUMBER	MATERIAL	COLOUR
DN	inch	Size	Parking		
12.5	1/2"	-08	Q1A0104N-08	STEEL	-
			Q1A0104N-08B	STEEL	-



### Q1AF104

PARKING  
FOR MQS-VB (BREAKING  
VALVES)

SIZE			PART NUMBER	MATERIAL	COLOUR
DN	inch	Size	Parking		
12.5	1/2"	-08	Q1AF104N-08	STEEL	-



## Q1AH104

PARKING

FOR MQS-VS  
(AGRICULTURAL VALVES)

SIZE			PART NUMBER	MATERIAL	COLOUR
DN	inch	Size	Parking		
12.5	1/2"	-08	Q1AH104N-08	STEEL	-



## Q1AP104

PARKING

FOR MQS-ST  
(SCREW TYPE MALE FOR TRUCK)

SIZE			PART NUMBER	MATERIAL	COLOUR
DN	inch	Size	Parking		
20	3/4"	-12	Q1AP104N-12	STEEL	-
25	1"	-16	Q1AP104N-16	STEEL	-

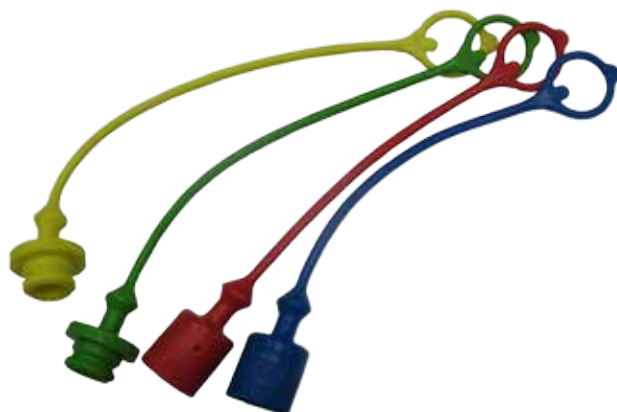

**Q1A0B00**

**Q1A1B00**

**PLUGS AND CAPS**

**FOR MQS-A (ISO A)**

**AND MQS-AP (ISO A UNDER PRESSURE) SERIES**

SIZE			PART NUMBER		MATERIAL	COLOUR
DN	inch	Size	Plug for female coupling	Cap for male coupling		
6.3	1/4"	-04	Q1A1B00R-04	Q1A0B00R-04	PVC	RED
			Q1A1B00Y-04	Q1A0B00Y-04	PVC	YELLOW
10	3/8"	-06	Q1A1B00R-06	Q1A0B00R-06	PVC	RED
			Q1A1B00Y-06	Q1A0B00Y-06	PVC	YELLOW
			Q1A1B00K-06	Q1A0B00K-06	PVC	BLACK
12.5	1/2"	-08	Q1A1B00R-08	Q1A0B00R-08	PVC	RED
			Q1A1B00B-08	Q1A0B00B-08	PVC	BLUE
			Q1A1B00G-08	Q1A0B00G-08	PVC	GREEN
			Q1A1B00Y-08	Q1A0B00Y-08	PVC	YELLOW
			Q1A1B00K-08	Q1A0B00K-08	PVC	BLACK
20	3/4"	-12	Q1A1B00R-12	Q1A0B00R-12	PVC	RED
			Q1A1B00Y-12	Q1A0B00Y-12	PVC	YELLOW
25	1"	-16	Q1A1B00R-16	Q1A0B00R-16	PVC	RED
			Q1A1B00Y-16	Q1A0B00Y-16	PVC	YELLOW



**Q1A5B00**

**Q1A4B00**

**PLUGS AND CAPS**

**FOR MQS-N (STANDARD SERIES)**

SIZE			PART NUMBER		MATERIAL	COLOUR
DN	inch	Size	Plug for female coupling	Cap for male coupling		
6.3	1/4"	-04	Q1A5B00R-04	Q1A4B00R-04	PVC	RED
			Q1A5B00B-04	Q1A4B00B-04	PVC	BLUE
			Q1A5B00G-04	Q1A4B00G-04	PVC	GREEN
10	3/8"	-06	Q1A5B00R-06	Q1A4B00R-06	PVC	RED
			Q1A5B00B-06	Q1A4B00B-06	PVC	BLUE
12.5	1/2"	-08	SEE PLUGS AND CAPS FOR ISO SERIES A			
20	3/4"	-12	Q1A5B00R-12	Q1A4B00R-12	PVC	RED
			Q1A5B00B-12	Q1A4B00B-12	PVC	BLUE
			Q1A5B00Y-12	Q1A4B00Y-12	PVC	YELLOW

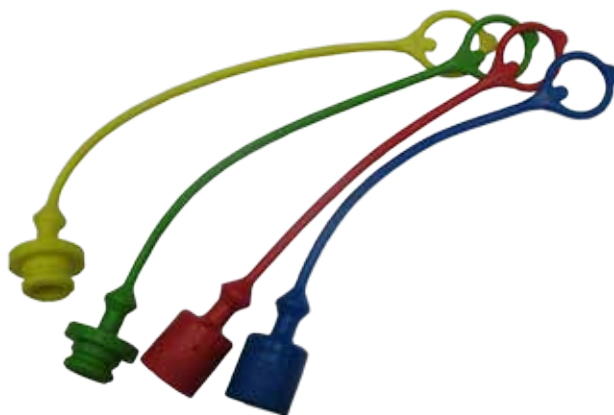

**Q1A1B00**

**PLUGS**

**MQS-AF (PUSH-PULL)**

**AND MQS-AFP (PUSH-PULL UNDER PRESSURE)**

SIZE			PART NUMBER		MATERIAL	COLOUR
DN	inch	Size	Plug for female coupling			
10	3/8"	-06	Q1A1B00R-06		PVC	RED
			Q1A1B00Y-06		PVC	YELLOW
12.5	1/2"	-08	Q1A1B00R-08		PVC	RED
			Q1A1B00B-08		PVC	BLUE
			Q1A1B00G-08		PVC	GREEN
			Q1A1B00Y-08		PVC	YELLOW
			Q1A1B00K-08		PVC	BLACK
			Q1A1B00H-08		PVC	WHITE
			Q1A1B00R-04		PVC	RED
6.3	1/4"	-04	Q1A1B00Y-04		PVC	YELLOW
			Q1A1B00R-12		PVC	RED
20	3/4"	-12	Q1A1B00Y-12		PVC	YELLOW
			Q1A1B00R-16		PVC	RED
25	1"	-16	Q1A1B00Y-16		PVC	YELLOW





**Q1A9B00**

**Q1A8B00**

**CAPS**

**FOR MQS-F (FLAT-FACE),  
MQS-FH (FLAT-FACE  
AND MQS-FP (MALE FLAT-FACE))**

SIZE			PART NUMBER		MATERIAL	COLOUR
DN	inch	Size	Plug for female coupling	Cap for male coupling		
6.3	1/4"	-04	Q1A9B00R-04	Q1A8B00R-04	PVC	RED
10	3/8"	-06	Q1A9B00R-06	Q1A8B00R-06	PVC	RED
12.5	1/2"	-08	Q1A9B00R-08	Q1A8B00R-08	PVC	RED
16	5/8"	-10	Q1A9B00R-10	Q1A8B00R-10	PVC	RED
20	3/4"	-12	Q1A9B00R-12	Q1A8B00R-12	PVC	RED
			Q1A9B00B-12	Q1A8B00B-12	PVC	BLUE
25	1"	-16	Q1A9B00R-16	Q1A8B00R-16	PVC	RED



**Q1AJA00**

**Q1AIA00**

**CAPS AND PLUGS**

**FOR MQS-SGR (SCREW-TYPE)  
AND MQS-SG (SCREW-TYPE)**

SIZE			PART NUMBER		MATERIAL	COLOUR
DN	inch	Size	Plug for female coupling	Cap for male coupling		
6.3	1/4"	-04	Q1AJA00R-04	Q1AIA00R-04	PE-HD	RED
10	3/8"	-06	Q1AJA00R-06	Q1AIA00R-06	PE-HD	RED
12.5	1/2"	-08	Q1AJA00R-08	Q1AIA00R-08	PE-HD	RED
20	3/4"	-12	Q1AJA00R-12	Q1AIA00R-12	PE-HD	RED
25	1"	-16	Q1AJA00R-16	Q1AIA00R-16	PE-HD	RED
40	1.1/2"	-24	Q1AJA00R-24	Q1AIA00R-24	PE-HD	RED



**Q1AN100**

**Q1AM100**

**CAPS AND PLUGS**

**FOR MQS-SC (SCREW-TYPE HYDRAULIC CYLINDERS)**

SIZE			PART NUMBER		MATERIAL	COLOUR
DN	inch	Size	Plug for female coupling	Cap for male coupling		
6.3	1/4"	-04	Q1AN100N-04	Q1AM100N-04	STEEL + PE-HD	-
10	3/8"	-06	Q1AN100N-06	Q1AM100N-06	STEEL + PE-HD	-



**Q1AQ100**

**Q1AP100**

**CAPS AND PLUGS**

**FOR MQS-ST (SCREW-TYPE TRUCKS)**

SIZE			PART NUMBER		MATERIAL	COLOUR
DN	inch	Size	Plug for female coupling	Cap for male coupling		
20	3/4"	-12	Q1AQ100N-12	Q1AP100N-12	STEEL	-
25	1"	-16	Q1AQ100N-16	Q1AP100N-16	STEEL	-



**Q1AL100**

**Q1AK100**

**CAPS AND PLUGS**

**FOR MQS-SH (SCREW-TYPE FOR VERY HIGH PRESSURE)**

SIZE			PART NUMBER		MATERIAL	COLOUR
DN	inch	Size	Plug for female coupling	Cap for male coupling		
6.3	1/4"	-04	Q1AL100N-04	Q1AK100N-04	STEEL + PE-HD	-
10	3/8"	-06	Q1AL100N-06	Q1AK100N-06	STEEL + PE-HD	-
12.5	1/2"	-08	Q1AL100N-08	Q1AK100N-08	STEEL + PE-HD	-
20	3/4"	-12	Q1AL100N-12	Q1AK100N-12	STEEL + PE-HD	-
25	1"	-16	Q1AL100N-16	Q1AK100N-16	STEEL + PE-HD	-



### Q1ACB00

CAPS

FOR MQS-D (DIAGNOSTIC)

SIZE			PART NUMBER	MATERIAL	COLOUR
DN	inch	Size	Plug for female coupling		
5	1/8"	-02	Q1ACB00K-02	PVC	BLACK



### Q1AEA00

PLUG

FOR MQS-VB  
(BRAKING VALVES)

SIZE			PART NUMBER	MATERIAL	COLOUR
DN	inch	Size			
12.5	1/2"	-08	Q1AEA00R-08	PLUG	PE-HD



### Q1AGA00

PLUG

FOR MQS-VS  
(AGRICULTURAL VALVES)

SIZE			PART NUMBER	MATERIAL	COLOUR
DN	inch	Size			
12.5	1/2"	-08	Q1AGA00R-08	PLUG	PE-HD



### Q1A1D02

**AUTOMATIC PLUG  
FOR MQS-AF (PUSH-PULL)**

SIZE			PART NUMBER	MATERIAL	COLOUR
DN	inch	Size			
12.5	1/2"	-08	Q1A1D02Y-08	POM	YELLOW
			Q1A1D02R-08	POM	RED
			Q1A1D02K-08	POM	BLACK
			Q1A1D02G-08	POM	GREEN
			Q1A1D02B-08	POM	BLUE
20	3/4"	-12	Q1A1D02Y-12	POM	YELLOW
			Q1A1D02R-12	POM	RED
			Q1A1D02K-12	POM	BLACK
			Q1A1D02G-12	POM	GREEN
			Q1A1D02B-12	POM	BLUE



### Q1A3B00

### Q1A2B00

**CAPS AND PLUGS  
FOR MQS-B (ISO B)**

SIZE			PART NUMBER		MATERIAL	COLOUR
DN	inch	Size	Plug for female coupling	Cap for male coupling		
6.3	1/4"	-04	Q1A3B00R-04	Q1A2B00R-04	PVC	RED



### Q1A9D02

**AUTOMATIC PLUG  
FOR MQS-F (FEMALE FLAT-FACE)  
AND MQS-FH (FEMALE FLAT\_FACE)**

SIZE			PART NUMBER	MATERIAL	COLOUR
DN	inch	Size			
12.5	1/2"	-08	Q1A9D02R-08	POM	RED
16	5/8"	-10	Q1A9D02B-10	POM	BLUE
20	3/4"	-12	Q1A9D02B-12	POM	BLUE



**Q1AJ100**

**Q1AI100**

**CAPS AND PLUGS**

**FOR MQS-SG AND MQS-SGR  
(SCREW-TYPE  
GERMAN MARKET)**

SIZE			PART NUMBER		MATERIAL	COLOUR
DN	inch	Size	Plug for female coupling	Cap for male coupling		
6.3	1/4"	-04	Q1AJ100N-04	Q1AI100N-04	STEEL	-
10	3/8"	-06	Q1AJ100N-06	Q1AI100N-06	STEEL	-
12.5	1/2"	-08	Q1AJ100N-08	Q1AI100N-08	STEEL	-
20	3/4"	-12	Q1AJ100N-12	Q1AI100N-12	STEEL	-
25	1"	-16	Q1AJ100N-16	Q1AI100N-16	STEEL	-



**Q1AL500**

**Q1AK500**

**CAPS AND PLUGS**

**FOR MQS-SH ( SCREW-TYPE  
VERY HIGH PRESSURE)**

SIZE			PART NUMBER		MATERIAL	COLOUR
DN	inch	Size	Plug for female coupling	Cap for male coupling		
31,5	1.1/4"	-20	Q1AL500N-20	Q1AK500N-20	ALUMINIUM	-



### Q1AW500N

**PLUG FOR FEMALE COUPLING  
FOR MQS-FS (SCREW-TYPE  
FLAT-FACE)**

SIZE			PART NUMBER	MATERIAL	COLOUR
DN	inch	Size	Plug for female coupling		
16	5/8"	-10	Q1AW500N-10	ALUMINIUM+STEEL	-
19	3/4"	-12	Q1AW500N-12	ALUMINIUM+STEEL	-
25	1"	-16	Q1AW500N-16	ALUMINIUM+STEEL	-
38	1½"	-25	Q1AW500N-24	ALUMINIUM+STEEL	-



### Q1AV500N

**CAP FOR MALE COUPLING  
FOR MQS-FS (SCREW-TYPE  
FLAT-FACE)**

SIZE			PART NUMBER	MATERIAL	COLOUR
DN	inch	Size	Plug for female coupling		
16	5/8"	-10	Q1AV500N-10	ALUMINIUM+STEEL	-
19	3/4"	-12	Q1AV500N-12	ALUMINIUM+STEEL	-
25	1"	-16	Q1AV500N-16	ALUMINIUM+STEEL	-
38	1½"	-25	Q1AV500N-24	ALUMINIUM+STEEL	-



### Q1A1013

**O-RING AND BACK-UP RING  
FOR MQS-A (ISO A)  
AND MQS-AP  
(ISO A UNDER PRESSURE)**

SIZE			PART NUMBER	KIT	MATERIAL	
DN	inch	Size			O-RING	BACK-UP RING
6.3	1/4"	-04	Q1A1013N-04	O-RING + BACK-UP RING	NBR	PTFE
10	3/8"	-06	Q1A1013N-06	O-RING + BACK-UP RING	NBR	PTFE
12.5	1/2"	-08	Q1A1013N-08	O-RING + BACK-UP RING	NBR	PTFE
20	3/4"	-12	Q1A1013N-12	O-RING + BACK-UP RING	NBR	PTFE
25	1"	-16	Q1A1013N-16	O-RING + BACK-UP RING	NBR	PTFE
31.5	1.1/4"	-20	Q1A1013N-20	O-RING + BACK-UP RING	NBR	PTFE
40	1.1/2"	-24	Q1A1013N-24	O-RING + BACK-UP RING	NBR	PTFE
51	2"	-32	Q1A1013N-32	O-RING + BACK-UP RING	NBR	PTFE



### Q1A5013

**O-RING AND BACK-UP RING  
FOR MQS-N  
(STANDARD SERIES)**

SIZE			PART NUMBER	KIT	MATERIAL	
DN	inch	Size			O-RING	BACK-UP RING
6.3	1/4"	-04	Q1A5013N-04	O-RING + BACK-UP RING	NBR	PTFE
10	3/8"	-06	Q1A5013N-06	O-RING + BACK-UP RING	NBR	PTFE
12.5	1/2"	-08	SEE SPARE PARTS FOR ISO SERIES			
20	3/4"	-12	Q1A5013N-12	O-RING + BACK-UP RING	NBR	PTFE
			Q1A5013N-12B	O-RING + BACK-UP RING	NBR	PTFE
25	1"	-16	Q1A5013N-16	O-RING + BACK-UP RING	NBR	PTFE
			Q1A5013N-16B	O-RING + BACK-UP RING	NBR	PTFE
			Q1A5013N-16C	O-RING + BACK-UP RING	NBR	PTFE
31.5	1.1/4"	-20	Q1A5013N-20	O-RING + BACK-UP RING	NBR	PTFE
40	1.1/2"	-24	Q1A5013N-24	O-RING + BACK-UP RING	NBR	PTFE

### Q1A1013

O-RING AND BACK-UP RING

FOR MQS-AF (PUSH-PULL)

AND MQS-AFP  
(PUSH-PULL UNDER PRESSURE)



SIZE			PART NUMBER	KIT	MATERIAL	
DN	inch	Size			O-RING	BACK-UP RING
6.3	1/4"	-04	Q1A1013N-04	O-RING + BACK-UP RING	NBR	PTFE
10	3/8"	-06	Q1A1013N-06	O-RING + BACK-UP RING	NBR	PTFE
12.5	1/2"	-08	Q1A1013N-08	O-RING + BACK-UP RING	NBR	PTFE
20	3/4"	-12	Q1A1013N-12	O-RING + BACK-UP RING	NBR	PTFE
25	1"	-16	Q1A1013N-16	O-RING + BACK-UP RING	NBR	PTFE

### Q1A3013

O-RING AND BACK-UP RING

FOR MQS-B (ISO B)



SIZE			PART NUMBER	KIT	MATERIAL	
DN	inch	Size			O-RING	BACK-UP RING
5	1/8"	-02	Q1A3013N-02	O-RING + BACK-UP RING	NBR	PTFE
6.3	1/4"	-04	Q1A3013N-04	O-RING + BACK-UP RING	NBR	PTFE
10	3/8"	-06	Q1A3013N-06	O-RING + BACK-UP RING	NBR	PTFE
12.5	1/2"	-08	Q1A3013N-08	O-RING + BACK-UP RING	NBR	PTFE
20	3/4"	-12	Q1A3013N-12	O-RING + BACK-UP RING	NBR	PTFE
25	1"	-16	Q1A3013N-16	O-RING + BACK-UP RING	NBR	PTFE

### Q1AJ013

O-RING AND BACK-UP RING

FOR MQS-SG

AND MQS-SGR (SCREW-TYPE)



SIZE			PART NUMBER	KIT	MATERIAL	
DN	inch	Size			O-RING	BACK-UP RING
6.3	1/4"	-04	Q1AJ013N-04	O-RING + BACK-UP RING	NBR	PTFE
10	3/8"	-06	Q1AJ013N-06	O-RING + BACK-UP RING	NBR	PTFE
12.5	1/2"	-08	Q1AJ013N-08	O-RING + BACK-UP RING	NBR	PTFE
20	3/4"	-12	Q1AJ013N-12	O-RING + BACK-UP RING	NBR	PTFE
25	1"	-16	Q1AJ013N-16	O-RING + BACK-UP RING	NBR	PTFE
40	1.1/2"	-24	Q1AJ013N-24	O-RING + BACK-UP RING	NBR	PTFE





### Q1AN013

**O-RING AND BACK-UP RING  
FOR MQS-SC  
(SCREW-TYPE HYDRAULIC  
CYLINDERS)**

SIZE			PART NUMBER	KIT	MATERIAL	
DN	inch	Size			O-RING	BACK-UP RING
6.3	1/4"	-04	Q1AN013N-04	O-RING + BACK-UP RING	NBR	PTFE
10	3/8"	-06	Q1AN013N-06	O-RING + BACK-UP RING	NBR	PTFE



### Q1AQ013

**O-RING AND BACK-UP RING  
FOR MQS-ST  
(SCREW-TYPE TRUCKS)**

SIZE			PART NUMBER	KIT	MATERIAL	
DN	inch	Size			O-RING	BACK-UP RING
20	3/4"	-12	Q1AQ013N-12	O-RING	NBR	-
25	1"	-16	Q1AQ013N-16	O-RING	NBR	-



### Q1AL013

**O-RING AND BACK-UP RING  
FOR MQS-SH  
(SCREW-TYPE FOR VERY  
HIGH PRESSURE)**

SIZE			PART NUMBER	KIT	MATERIAL	
DN	inch	Size			O-RING	BACK-UP RING
6.3	1/4"	-04	Q1AL013N-04	O-RING + BACK-UP RING	NBR	PTFE
10	3/8"	-06	Q1AL013N-06	O-RING + BACK-UP RING	NBR	PTFE
12.5	1/2"	-08	Q1AL013N-08	O-RING + BACK-UP RING	NBR	PTFE
20	3/4"	-12	Q1AL013N-12	O-RING + BACK-UP RING	NBR	PTFE
25	1"	-16	Q1AL013N-16	O-RING + BACK-UP RING	NBR	PTFE
31.5	1 1/4"	-20	Q1AL013N-20	O-RING + BACK-UP RING	NBR	PTFE





# **WATER CLEANING & BLASTING**



# WATER CLEANING & BLASTING

## INTRODUCTION

---

The water cleaning hose range offered by Manuli can be applied to both hobby and professional water cleaning machines with both hot and cold water (not suitable for vapour steam applications).

They are designed according to safety norm IEC-2 with a safety factor (burst / working pressure) of 4:1.

The water blasting hose range is designed for maximum robustness and ease of handling.

Given the importance of safety and performance when connected with any blasting application, this range has a complete, dedicated fittings range, whilst the safety factor (burst / working pressure) of 2,5:1 is compliant with international specifications (AS/NZ 4233.2, RMA-USA, ISO7751, BFPA-UK, EN 1829-2).

# WATER CLEANING & BLASTING INDEX

RANGE	HOSE	HOSE STRUCTURE	KEY PERFORMANCE	SECTION	ITEM
WATER CLEANING	K-JET	Wire braided	Pressure wash	W1	1
	SUPERJET	Wire braided	Pressure wash		2
	SUPERJET/PLUS	Wire braided	Pressure wash		3
	PROJET	Wire braided	Pressure wash		4



WATER BLASTING	GOLDENBLAST	Wire spiral	Safe waterblast technology	W2	1
	GOLDENBLAST/PLUS	Wire spiral	Safe waterblast technology		2
	GOLDENBLAST/SIX	Wire spiral	Safe waterblast technology		3

## GUIDE TO SELECT MANULI HOSE BY W.P.

HOSE SIZE	WORKING PRESSURE (bar)									
	DN	5	6	8	10	12	16	19	25	
	DASH	-3	-4	-5	-6	-8	-10	-12	-16	
K-JET			210	210	210	210				Safety factor burst/working pressure 4:1
SUPERJET			280	250						
SUPERJET/PLUS			400	350	330	275				
PROJET			400	400	400	350				
GOLDENBLAST					750	750				Safety factor burst/working pressure 2,5:1
GOLDENBLAST/PLUS					1250	1100		1000	700	
GOLDENBLAST/SIX						1450		1350		

# WATER CLEANING & BLASTING VISUAL INDEX

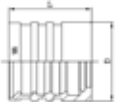

## WATER CLEANING

APPEARANCE	CODE	DESCRIPTION	SECTION	ITEM
	M00120	SKIVE FERRULE FOR WIRE BRAID HOSES		1
	M00910	SKIVE FERRULE FOR WIRE BRAID AND SPIRAL HOSES		1
	M03300	NO-SKIVE FERRULE FOR WIRE BRAID HOSES	W3	1
	M03400	NO-SKIVE FERRULE FOR WIRE BRAID HOSES		2

## MF2000® MULTIFIT TYPE INSERT

	M24913	WASH CLEANER FEMALE	W3	2
---	--------	---------------------	----	---



## WATER BLASTING

APPEARANCE	CODE	DESCRIPTION	SECTION	ITEM
	M01500	DOUBLE SKIVE FERRULE FOR HEAVY DUTY SPIRAL HOSES (4 PLY)		1
	M01700	DOUBLE SKIVE FERRULE FOR HEAVY DUTY SPIRAL HOSES (4 PLY)	W4	1
	M01800	DOUBLE SKIVE FERRULE FOR EXTRA DUTY SPIRAL HOSES (6 PLY)		1

# WATER CLEANING & BLASTING VISUAL INDEX

APPEARANCE	CODE	DESCRIPTION	SECTION	ITEM
------------	------	-------------	---------	------

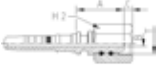
## MF2000® BLASTLOCK TYPE INSERT

	M57810	NPTF MALE 60° CONE SEAT - SAE J516/J514		2
	M65514	BSP FEMALE 50° CONE - BS5200/ISO 8434-6	W4	2
	M66613	METRIC O-RING FEMALE 24° CONE HEAVY DUTY - DIN 20066/ISO 12151-2 (SLIP-ON NUT)		3

## WATER BLASTING

APPEARANCE	CODE	DESCRIPTION	SECTION	ITEM
------------	------	-------------	---------	------

## MF3000® OPF TYPE FERRULE

	OPF3100	NO-SKIVE FLAT CRIMP FERRULE FOR BRAIDED HOSES	W5	1
---	---------	---	----	---



## K-JET (BLACK)

PRESSURE WASH - BLACK VERSION

### KEY FEATURES



- Dust free smooth surface
- Indelible branding
- Compact structure: easy handling, reduced bend radius
- Good abrasion resistance
- Designed to meet IEC-2 (safety factor 4:1)

### APPLICATIONS & FLUIDS



- Water-cleaning equipment, ideal for hobby and semiprofessional machines
- Water, mineral oils, vegetable and rape seed oils, glycol and polyglycol based oils, synthetic ester based oils, oils in aqueous emulsion

### TECHNICAL DATA

PART. REF.	HOSE SIZE			R.O.D.		O.D.		MAX W.P.		BURST		MIN.BEND		WEIGHT		FITTINGS	
	DN	dash	inch	mm	inch	mm	inch	bar	psi	bar	psi	mm	inch	g/m	lb/ft	Std1	Std2
H02003006*	6	- 4	1/4"	10,3	0,41	12,4	0,49	210	3040	840	12180	50	1,97	165	0,11	MF+M03300-04	OPF-04
H02003008*	8	- 5	5/16"	11,9	0,47	14,0	0,55	210	3040	840	12180	55	2,17	205	0,14	MF+M03300-05	
H02003010*	10	- 6	3/8"	14,5	0,57	16,5	0,65	210	3040	840	12180	65	2,56	300	0,20	MF+M03400-06	OPF-06
H02003012*	12	- 8	1/2"	17,7	0,70	19,9	0,78	210	3040	840	12180	90	3,54	410	0,28	MF+M03400-08	

#### CONTINUOUS SERVICE TEMPERATURE RANGE

15 °F / 275 °F  
-10 °C / 135 °C

#### TUBE

Water resistant synthetic rubber

#### REINFORCEMENT

One high tensile steel braid

#### COVER

Environment resistant synthetic rubber

#### APPLICABLE SPECS

MANULI® Design

#### TYPE APPROVALS

CU-TR

## K-JET (BLUE)

### PRESSURE WASH - BLUE VERSION

#### KEY FEATURES

- Dust free smooth surface
- Indelible branding
- Compact structure: easy handling, reduced bend radius
- Good abrasion resistance
- Designed to meet IEC-2 (safety factor 4:1)

#### APPLICATIONS & FLUIDS

- Water-cleaning equipment, ideal for hobby and semiprofessional machines
- Water, mineral oils, vegetable and rape seed oils, glycol and polyglycol based oils, synthetic ester based oils, oils in aqueous emulsion

#### TECHNICAL DATA

PART. REF.	HOSE SIZE			R.O.D.		O.D.		MAX W.P.		BURST		MIN.BEND		WEIGHT		FITTINGS	
	DN	dash	inch	mm	inch	mm	inch	bar	psi	bar	psi	mm	inch	g/m	lb/ft	Std1	Std2
H02008006*	6	- 4	1/4"	10,3	0,41	12,4	0,49	210	3040	840	12180	50	1,97	165	0,11	MF+M03300-04	OPF-04
H02008008*	8	- 5	5/16"	11,9	0,47	14,0	0,55	210	3040	840	12180	55	2,17	200	0,13	MF+M03300-05	
H02008010*	10	- 6	3/8"	14,5	0,57	16,5	0,65	210	3040	840	12180	65	2,56	295	0,20	MF+M03400-06	OPF-06
H02008012*	12	- 8	1/2"	17,7	0,70	19,9	0,78	210	3040	840	12180	90	3,54	405	0,27	MF+M03400-08	

#### CONTINUOUS SERVICE TEMPERATURE RANGE

15 °F / 275 °F  
-10 °C / 135 °C

#### TUBE

Water resistant synthetic rubber

#### REINFORCEMENT

One high tensile steel braid

#### COVER

Environment resistant synthetic rubber

#### APPLICABLE SPECS

MANULI® Design

#### TYPE APPROVALS

CU-TR

## SUPERJET (BLACK)

PRESSURE WASH - BLACK VERSION



### KEY FEATURES

- Dust free smooth surface
- Indelible branding
- Easy handling
- Good abrasion resistance
- Designed to meet IEC-2 (safety factor 4:1)

### APPLICATIONS & FLUIDS



- Water-cleaning equipment, ideal for hobby and semiprofessional machines
- Water, mineral oils, vegetable and rape seed oils, glycol and polyglycol based oils, synthetic ester based oils, oils in aqueous emulsion

### TECHNICAL DATA

PART. REF.	HOSE SIZE			R.O.D.		O.D.		MAX W.P.		BURST		MIN.BEND		WEIGHT		FITTINGS	
	DN	dash	inch	mm	inch	mm	inch	bar	psi	bar	psi	mm	inch	g/m	lb/ft	Std1	Std2
H02001006*	6	- 4	1/4"	11,2	0,44	13,3	0,52	280	4060	1120	16240	100	3,94	225	0,15	MF+M03400-04	OPF-04
H02001008*	8	- 5	5/16"	12,8	0,50	14,9	0,59	250	3620	1000	14500	114	4,49	260	0,17	MF+M03400-05	OPF-05

#### CONTINUOUS SERVICE TEMPERATURE RANGE

15 °F / 275 °F  
-10 °C / 135 °C

#### MAX OPERATING TEMPERATURE

150 °C, 300 °F

#### TUBE

Water resistant synthetic rubber

#### REINFORCEMENT

One high tensile steel braid

#### COVER

Environment resistant synthetic rubber

#### APPLICABLE SPECS

MANULI® Design

#### TYPE APPROVALS

CU-TR

## SUPERJET (BLUE)

### PRESSURE WASH - BLUE VERSION

#### KEY FEATURES

- Dust free smooth surface
- Indelible branding
- Easy handling
- Good abrasion resistance
- Designed to meet IEC-2 (safety factor 4:1)

#### APPLICATIONS & FLUIDS

- Water-cleaning equipment, ideal for hobby and semiprofessional machines
- Water, mineral oils, vegetable and rape seed oils, glycol and polyglycol based oils, synthetic ester based oils, oils in aqueous emulsion

#### TECHNICAL DATA

PART. REF.	HOSE SIZE			R.O.D.		O.D.		MAX W.P.		BURST		MIN.BEND		WEIGHT		FITTINGS	
	DN	dash	inch	mm	inch	mm	inch	bar	psi	bar	psi	mm	inch	g/m	lb/ft	Std1	Std2
H02002006*	6	- 4	1/4"	11,2	0,44	13,4	0,53	280	4060	1120	16240	100	3,94	225	0,15	MF+M03400-04	OPF-04
H02002008*	8	- 5	5/16"	12,8	0,50	15,0	0,59	250	3620	1000	14500	114	4,49	265	0,18	MF+M03400-05	OPF-05

#### CONTINUOUS SERVICE TEMPERATURE RANGE

15 °F / 275 °F  
-10 °C / 135 °C

#### MAX OPERATING TEMPERATURE

150 °C, 300 °F

#### TUBE

Water resistant synthetic rubber

#### REINFORCEMENT

One high tensile steel braid

#### COVER

Environment resistant synthetic rubber

#### APPLICABLE SPECS

MANULI® Design

#### TYPE APPROVALS

CU-TR

## SUPERJET/PLUS (BLACK)

PRESSURE WASH - BLACK VERSION



### KEY FEATURES

- Very high pressure resistance
- Lightness and flexibility
- Easy handling
- Good abrasion resistance
- Designed to meet IEC-2 (safety factor 4:1)

### APPLICATIONS & FLUIDS

- Professional water-cleaning machines
- Water, mineral oils, vegetable and rape seed oils, glycol and polyglycol based oils, synthetic ester based oils, oils in aqueous emulsion

### TECHNICAL DATA

PART. REF.	HOSE SIZE			R.O.D.		O.D.		MAX W.P.		BURST		MIN. BEND		WEIGHT		FITTINGS	
	DN	dash	inch	mm	inch	mm	inch	bar	psi	bar	psi	mm	inch	g/m	lb/ft	Std1	Std2
H01A78006*	6	- 4	1/4"	12,7	0,50	14,7	0,58	400	5800	1600	23200	55	2,17	370	0,25	MF+M03400-04	
H01A78008*	8	- 5	5/16"	14,3	0,56	16,3	0,64	350	5070	1400	20300	60	2,36	410	0,28	MF+M03400-05	
H01A78010*	10	- 6	3/8"	15,0	0,59	16,8	0,66	330	4780	1320	19140	65	2,56	390	0,26	MF+M03400-06	
H01A78012*	12	- 8	1/2"	18,5	0,73	20,3	0,80	275	3980	1100	15950	80	3,15	480	0,32	MF+M03400-08	

#### CONTINUOUS SERVICE TEMPERATURE RANGE

15 °F / 275 °F  
-10 °C / 135 °C

#### MAX OPERATING TEMPERATURE

150 °C, 300 °F

#### TUBE

Water resistant synthetic rubber

#### REINFORCEMENT

Two high tensile steel braids

#### COVER

Environment resistant synthetic rubber

#### APPLICABLE SPECS

MANULI® Design

#### TYPE APPROVALS

CU-TR

## SUPERJET/PLUS (BLUE)

PRESSURE WASH - BLUE VERSION



### KEY FEATURES

- Very high pressure resistance
- Lightness and flexibility
- Easy handling
- Good abrasion resistance
- Designed to meet IEC-2 (safety factor 4:1)

### APPLICATIONS & FLUIDS

- Professional water-cleaning machines
- Water, mineral oils, vegetable and rape seed oils, glycol and polyglycol based oils, synthetic ester based oils, oils in aqueous emulsion

### TECHNICAL DATA

PART. REF.	HOSE SIZE			R.O.D.		O.D.		MAX W.P.		BURST		MIN. BEND		WEIGHT		FITTINGS	
	DN	dash	inch	mm	inch	mm	inch	bar	psi	bar	psi	mm	inch	g/m	lb/ft	Std1	Std2
H01A79006*	6	- 4	1/4"	12,7	0,50	14,7	0,58	400	5800	1600	23200	55	2,17	365	0,25	MF+M03400-04	
H01A79008*	8	- 5	5/16"	14,3	0,56	16,3	0,64	350	5070	1400	20300	60	2,36	405	0,27	MF+M03400-05	
H01A79010*	10	- 6	3/8"	15,0	0,59	16,8	0,66	330	4780	1320	19140	65	2,56	390	0,26	MF+M03400-06	
H01A79012*	12	- 8	1/2"	18,5	0,73	20,3	0,80	275	3980	1100	15950	80	3,15	475	0,32	MF+M03400-08	

#### CONTINUOUS SERVICE TEMPERATURE RANGE

15 °F / 275 °F  
-10 °C / 135 °C

#### MAX OPERATING TEMPERATURE

150 °C, 300 °F

#### TUBE

Water resistant synthetic rubber

#### REINFORCEMENT

Two high tensile steel braids

#### COVER

Environment resistant synthetic rubber

#### APPLICABLE SPECS

MANULI® Design

#### TYPE APPROVALS

CU-TR

## PROJET (BLACK)

PRESSURE WASH - BLACK VERSION



### KEY FEATURES

- Very high pressure resistance
- Lightness and flexibility
- Easy handling
- Good abrasion resistance
- Designed to meet IEC-2 (safety factor 4:1)
- Skive fitting solution for maximum robustness in professional long lasting applications

### APPLICATIONS & FLUIDS

- Professional water-cleaning machines
- Water, mineral oils, vegetable and rape seed oils, glycol and polyglycol based oils, synthetic ester based oils, oils in aqueous emulsion

### TECHNICAL DATA

PART. REF.	HOSE SIZE			R.O.D.		O.D.		MAX W.P.		BURST		MIN. BEND		WEIGHT		FITTINGS	
	DN	dash	inch	mm	inch	mm	inch	bar	psi	bar	psi	mm	inch	g/m	lb/ft	Std1	Std2
H01A94006*	6	- 4	1/4"	11,3	0,44	13,1	0,52	400	5800	1600	23200	45	1,77	280	0,19	MF+M00120-04	
H01A94008*	8	- 5	5/16"	12,9	0,51	14,6	0,57	400	5800	1600	23200	100	3,94	315	0,21	MF+M00120-05	
H01A94010*	10	- 6	3/8"	16,7	0,66	18,5	0,73	400	5800	1600	23200	130	5,12	520	0,35	MF+M00910-06	
H01A94012*	12	- 8	1/2"	19,8	0,78	21,8	0,86	350	5070	1400	20300	178	7,01	660	0,44	MF+M00910-08	

#### CONTINUOUS SERVICE TEMPERATURE RANGE

15 °F / 275 °F  
-10 °C / 135 °C

#### MAX OPERATING TEMPERATURE

150 °C, 300 °F

#### TUBE

Water resistant synthetic rubber

#### REINFORCEMENT

Two high tensile steel braids

#### COVER

Environment resistant synthetic rubber

#### APPLICABLE SPECS

MANULI® Design

#### TYPE APPROVALS

CU-TR

## PROJET (BLUE)

PRESSURE WASH - BLUE VERSION



### KEY FEATURES

- Very high pressure resistance
- Lightness and flexibility
- Easy handling
- Good abrasion resistance
- Designed to meet IEC-2 (safety factor 4:1)
- Skive fitting solution for maximum robustness in professional long lasting applications

### APPLICATIONS & FLUIDS

- Professional water-cleaning machines
- Water, mineral oils, vegetable and rape seed oils, glycol and polyglycol based oils, synthetic ester based oils, oils in aqueous emulsion

### TECHNICAL DATA

PART. REF.	HOSE SIZE			R.O.D.		O.D.		MAX W.P.		BURST		MIN. BEND		WEIGHT		FITTINGS	
	DN	dash	inch	mm	inch	mm	inch	bar	psi	bar	psi	mm	inch	g/m	lb/ft	Std1	Std2
H01A95006*	6	- 4	1/4"	11,3	0,44	13,1	0,52	400	5800	1600	23200	45	1,77	275	0,18	MF+M00120-04	
H01A95008*	8	- 5	5/16"	12,9	0,51	14,6	0,57	400	5800	1600	23200	100	3,94	310	0,21	MF+M00120-05	
H01A95010*	10	- 6	3/8"	16,7	0,66	18,5	0,73	400	5800	1600	23200	130	5,12	520	0,35	MF+M00910-06	
H01A95012*	12	- 8	1/2"	19,8	0,78	21,8	0,86	350	5070	1400	20300	178	7,01	650	0,44	MF+M00910-08	

#### CONTINUOUS SERVICE TEMPERATURE RANGE

15 °F / 275 °F  
-10 °C / 135 °C

#### MAX OPERATING TEMPERATURE

150 °C, 300 °F

#### TUBE

Water resistant synthetic rubber

#### REINFORCEMENT

Two high tensile steel braids

#### COVER

Environment resistant synthetic rubber

#### APPLICABLE SPECS

MANULI® Design

#### TYPE APPROVALS

CU-TR



## GOLDENBLAST

SAFE WATERBLAST TECHNOLOGY



### KEY FEATURES

- Basic hose line for scale removing applications
- Compactness, lightness and flexibility
- Safety factor 2,5:1 (accepted world standard as specified by RMA-USA, BFPA-UK, DIN-Germany, ISO 7751)
- High abrasion resistant cover

### APPLICATIONS & FLUIDS



- Waterblasting, scale removing applications using extreme high working pressures:
  - building and industrial sectors (roadworks, removal of concrete from reinforced concrete structures safeguarding metal components);
  - scale removal ships hulls in shipyard;
  - dust elimination
- Water, water soap, emulsions

### TECHNICAL DATA

PART. REF.	HOSE SIZE			R.O.D.		O.D.		MAX W.P.		BURST		MIN. BEND		WEIGHT		FITTINGS	
	DN	dash	inch	mm	inch	mm	inch	bar	psi	bar	psi	mm	inch	g/m	lb/ft	Std1	Std2
H10072010*	10	- 6	3/8"	17,6	0,69	20,2	0,80	750	10870	1875	27190	180	7,09	756	0,51	BL+M01700-06	
H10072A12*	12	- 8	1/2"	20,4	0,80	23,0	0,91	750	10870	1875	27190	220	8,66	905	0,61	BL+M01700-08	

#### CONTINUOUS SERVICE TEMPERATURE

**RANGE**  
15 °F / 158 °F  
-10 °C / 70 °C

#### MAX OPERATING TEMPERATURE

93 °C, 200 °F

#### TUBE

Water resistant synthetic rubber

#### REINFORCEMENT

Four high tensile steel spirals

#### COVER

Synthetic rubber with high temperature, ozone and abrasion resistance

#### APPLICABLE SPECS

MANULI® Design, Australian Std. AS/NZS 4233.2

#### TYPE APPROVALS

CU-TR; MSHA

## GOLDENBLAST/PLUS

SAFE WATERBLAST TECHNOLOGY



### KEY FEATURES

- Hose line for waterblasting with pressures up to 1250 bar
- Compactness, lightness and flexibility
- Safety factor 2,5:1 (accepted world standard as specified by RMA-USA, BFPA-UK, DIN-Germany, ISO 7751)
- High abrasion resistance cover

### APPLICATIONS & FLUIDS



- Waterblasting, scale removing applications using extreme high working pressures:
  - building and industrial sectors (roadworks, removal of concrete from reinforced concrete structures safeguarding metal components);
  - scale removal ships hulls in shipyard;
  - dust elimination
- Water, water soap, emulsions

### TECHNICAL DATA

PART. REF.	HOSE SIZE			R.O.D.		O.D.		MAX W.P.		BURST		MIN. BEND		WEIGHT		FITTINGS	
	DN	dash	inch	mm	inch	mm	inch	bar	psi	bar	psi	mm	inch	g/m	lb/ft	Std1	Std2
H10066010*	10	- 6	3/8"	17,4	0,69	20,0	0,79	1250	18120	3125	45320	230	9,06	800	0,54	BL+M01700-06	
H10066A12*	12	- 8	1/2"	21,5	0,85	24,1	0,95	1100	15950	2750	39880	230	9,06	1110	0,75	BL+M01700-08	
H10066019*	19	- 12	3/4"	29,0	1,14	32,0	1,26	1000	14500	2500	36250	250	9,84	1730	1,16	BL+M01700-12	
H10066025*	25	- 16	1"	35,1	1,38	38,1	1,50	700	10150	1750	25380	250	9,84	2040	1,37	BL+M01500-16	

#### CONTINUOUS SERVICE TEMPERATURE RANGE

15 °F / 158 °F  
-10 °C / 70 °C

#### MAX OPERATING TEMPERATURE

93 °C, 200 °F

#### TUBE

Water resistant synthetic rubber

#### REINFORCEMENT

Four high tensile steel spirals

#### COVER

Synthetic rubber with very high temperature, ozone and abrasion resistance

#### APPLICABLE SPECS

MANULI® Design, Australian Std. AS/NZS 4233.2

#### TYPE APPROVALS

CU-TR; MSHA

## GOLDENBLAST/SIX

SAFE WATERBLAST TECHNOLOGY



### KEY FEATURES

- Six wire spiral hose dedicated to severe applications with pressures up to 1450 bar
- Compactness, lightness and flexibility
- Safety factor 2,5:1 (accepted world standard as specified by RMA-USA, BFPA-UK, DIN-Germany, ISO 7751)
- High abrasion resistance cover

### APPLICATIONS & FLUIDS



- Waterblasting, scale removing applications using extreme high working pressures:
  - building and industrial sectors (roadworks, removal of concrete from reinforced concrete structures safeguarding metal components);
  - scale removal ships hulls in shipyard;
  - dust elimination
- Water, water soap, emulsions

### TECHNICAL DATA

PART. REF.	HOSE SIZE			R.O.D.		O.D.		MAX W.P.		BURST		MIN. BEND		WEIGHT		FITTINGS	
	DN	dash	inch	mm	inch	mm	inch	bar	psi	bar	psi	mm	inch	g/m	lb/ft	Std1	Std2
H10067012*	12	- 8	1/2"	25,9	1,02	28,9	1,14	1450	21030	3625	52570	250	9,84	1880	1,26	BL+M01800-08	
H10067019*	19	- 12	3/4"	32,4	1,28	35,4	1,39	1350	19580	3375	48950	280	11,02	2630	1,77	BL+M01800-12	

#### CONTINUOUS SERVICE TEMPERATURE

**RANGE**  
15 °F / 158 °F  
-10 °C / 70 °C

#### MAX OPERATING TEMPERATURE

93 °C, 200 °F

#### TUBE

Water resistant synthetic rubber

#### REINFORCEMENT

Six high tensile steel spirals

#### COVER

Synthetic rubber with very high temperature, ozone and abrasion resistance

#### APPLICABLE SPECS

MANULI® Design, Australian Std. AS/NZS 4233.2

#### TYPE APPROVALS

CU-TR; MSHA

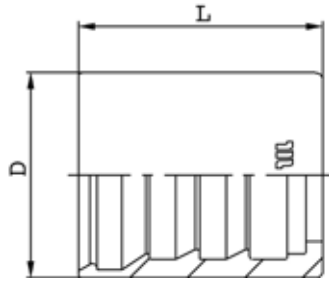

FERRULE

## M00110/M00120/M00130

SKIVE FERRULE FOR WIRE BRAID HOSES

PART. REF.	HOSE BORE			DIMENSIONS mm							
	DN	Dash	inch			D	L				
M00120-04	6	- 4	1/4"			19,5	28				
M00120-05	8	- 5	5/16"			20	28,6				

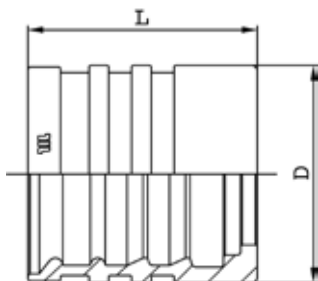

FERRULE

## M00910/M00920/M00930

SKIVE FERRULE FOR WIRE BRAID AND SPIRAL HOSES

PART. REF.	HOSE BORE			DIMENSIONS mm							
	DN	Dash	inch			D	L				
M00910-06	10	- 6	3/8"			26	33				
M00910-08	12	- 8	1/2"			30	34				

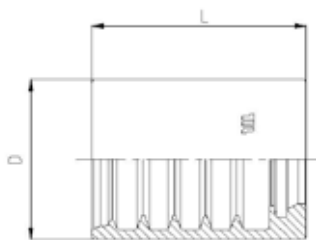

FERRULE

## M03300

NO-SKIVE FERRULE FOR WIRE BRAID HOSES

PART. REF.	HOSE BORE			DIMENSIONS mm							
	DN	Dash	inch			D	L				
M03300-04	6	- 4	1/4"			20,5	27,5				
M03300-05	8	- 5	5/16"			22,8	28,5				

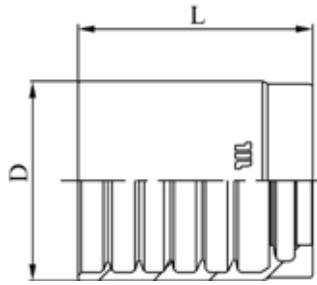

FERRULE

**M03400**

NO-SKIVE FERRULE FOR WIRE BRAID HOSES

PART. REF.	HOSE BORE			DIMENSIONS mm							
	DN	Dash	inch			D	L				
M03400-04	6	- 4	1/4"			23	30,1				
M03400-05	8	- 5	5/16"			24	30				
M03400-06	10	- 6	3/8"			26	31,1				
M03400-08	12	- 8	1/2"			29	34				
M03400-10	16	- 10	5/8"			33	37				
M03400-12	19	- 12	3/4"			37	42				

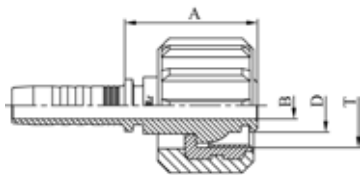

CONNECTIONS - CLEANING

**M24913**

WASH CLEANER FEMALE

PART. REF.	HOSE BORE			Thread	DIMENSIONS mm							
	DN	Dash	inch		T	B	A	D				
M24913-04-22	6	- 4	1/4"	M 22x1,5		4	34	13,9				
M24913-05-22	8	- 5	5/16"	M 22x1,5		5,5	34	13,9				
M24913-06-22	10	- 6	3/8"	M 22x1,5		7	34,5	13,9				

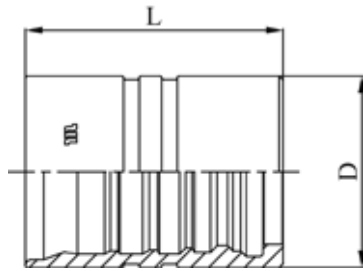

FERRULE

**M01500**

DOUBLE SKIVE FERRULE FOR HEAVY DUTY SPIRAL HOSES (4 PLY)

PART. REF.	HOSE BORE			DIMENSIONS mm							
	DN	Dash	inch			D	L				
M01500-16	25	- 16	1"			48	64,5				

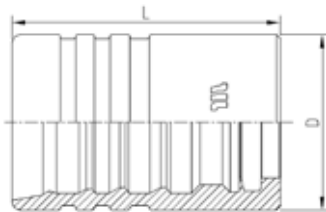

FERRULE - BLASTING

**M01700**

DOUBLE SKIVE FERRULE FOR EXTRA DUTY SPIRAL HOSES (4 PLY)

PART. REF.	HOSE BORE			DIMENSIONS mm							
	DN	Dash	inch			D	L				
M01700-06	10	- 6	3/8"			29,7	57,5				
M01700-08	12	- 8	1/2"			34	65				
M01700-12	19	- 12	3/4"			45,1	69				

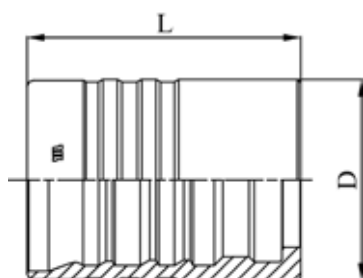

FERRULE - BLASTING

**M01800**

DOUBLE SKIVE FERRULE FOR EXTRA DUTY SPIRAL HOSES (6 PLY)

PART. REF.	HOSE BORE			DIMENSIONS mm							
	DN	Dash	inch			D	L				
M01800-08	12	- 8	1/2"			38,3	64,4				
M01800-12	19	- 12	3/4"			48,6	69				

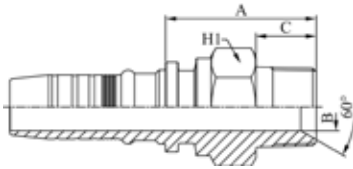

## CONNECTIONS - BLASTING

### M57810 (DN 16: M52810)

NPTF MALE 60° CONE SEAT - SAE J516/J514

PART. REF.	HOSE BORE			Thread		DIMENSIONS mm						
	DN	Dash	inch			T	B	A	C			
M57810-06-06	10	- 6	3/8"	3/8" - 18		8,5	38	15,5	22			
M57810-08-08	12	- 8	1/2"	1/2" - 14		10	44,5	21	27			
M57810-12-12	19	- 12	3/4"	3/4" - 14		15	49,5	21	32			
M52810-16-16	25	- 16	1"	1" - 11		19,5	55	24,2	41			

The BLASTLOCK fittings have to be used with the GOLDENBLAST hoses only, that are suggested for waterblasting applications. For hydraulic applications please refer to dedicated fittings (ILP)

## CONNECTIONS - BLASTING

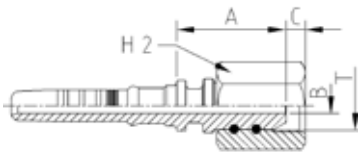

### M65514

BSP FEMALE 60° CONE  
(BS5200 - ISO 8434-6)

PART. REF.	HOSE BORE			Thread		DIMENSIONS mm						
	DN	Dash	inch			T	B	A	C			
M65514-06-06	10	- 6	3/8"	3/8" - 19		4,8	34,5	6	24			
M65514-08-08	12	- 8	1/2"	1/2" - 14		9	37	6,5	30			
M65514-12-12	19	- 12	3/4"	3/4" - 14		12	43	8,7	36			

The BLASTLOCK fittings have to be used with the GOLDENBLAST hoses only, that are suggested for waterblasting applications. For hydraulic applications please refer to dedicated fittings (ILP)

"B" dimension does not comply with: BS5200 and ISO8434-6 spec.

## CONNECTIONS - BLASTING

### M66613

**METRIC O-RING FEMALE 24° CONE HEAVY DUTY - DIN 20066/ISO 12151-2 (SLIP-ON NUT)**

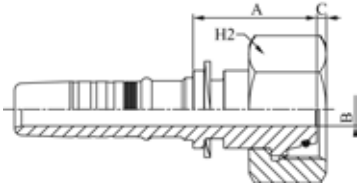

PART. REF.	HOSE BORE			Thread	Pipe	DIMENSIONS mm						
	DN	Dash	inch			T	mm	B	A	C	H2	
M66613-06-22	10	- 6	3/8"	M 22x1,5	14	4,8	32	3,5	27			
M66613-06-24	10	- 6	3/8"	M 24x1,5	16	6,3	34	4	32			
M66613-08-24	12	- 8	1/2"	M 24x1,5	16	9	35,5	4	32			
M66613-12-36	19	- 12	3/4"	M 36x2	25	12	44,5	3,4	46			
M66613-16-42	25	- 16	1"	M 42x2	30	19,5	43,5	5,3	50			

The BLASTLOCK fittings have to be used with the GOLDENBLAST hoses only, that are suggested for waterblasting applications. For hydraulic applications please refer to dedicated fittings (ILP)



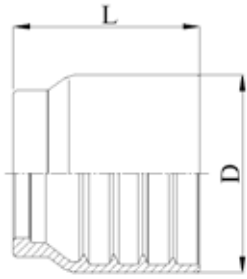

FERRULE

**OPF3100**

**NO-SKIVE FLAT CRIMP  
FERRULE FOR BRAIDED HOSES**

PART. REF.	HOSE BORE			DIMENSIONS mm									
	DN	Dash	inch			D	L						
OPF3100-04	6	- 4	1/4"			23	27,5						
OPF3100-05	8	- 5	5/16"			24	27						
OPF3100-06	10	- 6	3/8"			26,5	29,5						

# BLASTLOCK TYPE

## ASSEMBLING INSTRUCTIONS



The following assembling instructions are strongly recommended for heavy-duty applications

The crimping operation to apply BLASTLOCK fittings must be carried out with proper high performance crimping/assembling machines, with a crimping force higher than 2,800-3,000 kN, and approved by Manuli Hydraulics. This is in order to guarantee the optimum coupling assembly deformations and correct hose gripping.

It is recommended that the detailed assembling instructions are followed. These are supplied by Manuli Hydraulics to customers, assemblers and operators using the integrated package, GOLDENBLAST hose & BLASTLOCK fittings.

Each assembly must be pressure tested at the pressure level required by the reference specifications (e.g. EN 1829-2 requirement is 1.5 times the WP for minimum 30 seconds) and taking into consideration all safety implications.

Specialised personnel are recommended for the assembling operation of BLASTLOCK fittings.

PART REF.	THREAD SIZE	OR SUPPLIED (NBR 90 ShA)	TIGHTENING TORQUE (Nm)
M66613-6-22	M 22 x 1.5	10 x 2	70
M66613-08-24	M 24 x 1.5	12 x 2	100
M66613-12-36	M 36 x 2	20.3 x 2.4	190
M66613-16-42	M 42 x 2	25.3 x 2.4	220

# BLASTLOCK TYPE

## RECOMMENDATIONS

Please see the following recommendations for the safe and correct use of the Manuli Goldenblast product line:

- **Don't mix and match:** MRI highly recommends the use of its integrated waterblasting package. The use of alternative hose or fittings can result in poor quality and reliability of the assembly.
- In line with international regulations, **all** waterblasting assemblies should be **tested to 150% of the indicated maximum static working pressure** before using.
- If waterblasting assemblies are used at a pressure exceeding the maximum working pressure indicated, the assemblies structure can cause an over-stressed situation. For the same reason **pulsating pressure** situations also need to be avoided.
- **Relief valves** should be used to preserve waterblasting equipment and hose assemblies.
- When **safety devices** are applied to prevent fitting blow-off, hose elongation and contraction needs to be taken in consideration. Under pressure, the hose length can vary between -4% to +2%.
- **Waterblasting assemblies should never be used in "hang down" positions.** These conditions can cause hose reinforcement restriction to contraction/elongation and over-stress fittings when supporting the weight of the hanging hose.
- Strictly avoid applying any **external force** on the hose assembly, such as axial tension, twisting, kinking or crushing.
- **Temperature** influences the resistance to leakage. Working temperature should be maintained below 70°C.
- Hose assemblies need to be replaced in case of damage, such as:
  - ✓ hose cover abrasion, cuts, chemical attack, corrosion
  - ✓ reinforcement crushing or twisting
- **High pressure water must always be considered as extremely dangerous.** Anyone handling waterblasting equipment should wear proper protective clothing, boots and eye protection.





# **ASSEMBLY MACHINES**



# ASSEMBLY MACHINES

## INTRODUCTION

---

Manuli assembling machines are part of our integrated product range and are designed according to high quality standards and optimised through Manuli's extensive experience in the hydraulic market.

Manuli assembling machines are recommended for a high-performance, safe hose assembling procedure.

All Manuli assembling machines are tested and approved in both laboratory and field validation exercises.

The following index offers a guideline to aid selection of the proper machine with reference to the applications and performance requested.

Special machines (not included in this catalogue) are available upon request, as well as original spare parts.

Manuli hose and fittings products must be assembled in strict accordance with Manuli instructions and limitations.

Don't mix and match: use always Manuli original couplings and hoses.

Manuli hose, couplings and assembling machines are tested as an effective and reliable system. The use of different products and machines may cause premature hose failures, property damage, serious injury or death.

**MANULI MAKES NO WARRANTIES, EXPRESS OR IMPLIED, AND ASSUMES NO RESPONSIBILITY OR LIABILITY FOR ANY LOSS OR DAMAGE, WHETHER DIRECT, INDIRECT, CONSEQUENTIAL OR INCIDENTAL WHICH MIGHT ARISE OUT OF CRIMPED HOSE ASSEMBLIES NOT PRODUCED FROM GENUINE MANULI HOSE FITTINGS, HOSE AND EQUIPMENT, IN CONFORMANCE WITH MANULI PROCESS SPECIFICATIONS FOR EACH SPECIFIC HOSE ASSEMBLY.**

The latest edition of the Manuli crimping booklet is the only official guide to selecting proper hose and fittings combinations and for determining crimping compatibility and parameters.

# ASSEMBLY MACHINES INDEX

	MODEL	MACHINE TYPE	APPLICATION SECTOR	MACHINE PERFORMANCE	SECTION	ITEM
CRIMPING	MHP 80	Hand pump, portable	On site repair	Manual machine for small sizes	M1	1
	MHP 137	Hand pump, portable	On site repair	Manual machine for small/medium sizes		2
	MB 137 PLUS	Benchtop	Aftermarket service	Medium crimping force, small/medium sizes, limited productivity		3
	MB 240	Benchtop	Aftermarket service	Medium crimping force, medium productivity		4
	MB 350	Benchtop: very high crimp force	Aftermarket service	High crimping force, medium productivity, large size		5
	MB 350 L	Benchtop: very high crimp force	Aftermarket service	High crimping force, medium productivity, large size		6
	MV 137	Field service and mobile workshop	On site repair mobile van	Medium crimping force, limited productivity		7
	MV 137 L	Field service and mobile workshop	On site repair mobile van	Medium crimping force, limited productivity		8
	MV 240	Field service and mobile workshop	On site repair mobile van	Medium crimping force, limited productivity		9
	MV 240 L	Field service and mobile workshop	On site repair mobile van	Medium crimping force, limited productivity		10
	MV 350	Field service and mobile or container workshop	On site repair mobile van	High crimping force, medium productivity, large size		11
	GOLDENCRIMP 450	Benchtop	Field maintenance shops, wide hose range	Very high crimping force, tough environments, large size		12
	MVB 140	Vertical benchtop, cage dies	On site repair; Aftermarket service	Medium crimping force, small/medium sizes, limited productivity		13
	MS 140	Stand type crimp machine	Assembling production unit, small/medium sizes	Medium crimping force, high productivity for small - medium bore		14
	MS 280 L	Stand-type crimp machine, SCS control	Aftermarket service, First OEM eq	Medium crimping force, whole size range		15
	MS 320	Stand-type crimp machine, SCS control	Assembling production unit, OEM and distribution	High crimping force, high productivity, large size		16
	MS 480	Stand-type crimp machine, SCS control	Assembling production unit, OEM and large bore focus	Very high crimping force, high productivity, very large opening		17
	MS 800	Stand-type crimp machine, SCS control	Assembling production unit	Very high crimping force for large bore hose focus		18



# ASSEMBLY MACHINES INDEX



	MODEL	MACHINE TYPE	APPLICATION SECTOR	MACHINE PERFORMANCE	SECTION	ITEM
CUTTING	M22 CUT	Benchtop	Aftermarket service	Medium size capacity	M2	1
	M30 CUT E	Benchtop cutting machine, optional skiving	Aftermarket service	Wide hose range capacity		2
	M30 CUT L	Stand type cutting machine	Aftermarket service (smoke absorption integrated)	Wide hose range capacity		3
	M30 CUT & SKIVE	Benchtop: integrated cutting & skiving	Aftermarket service	Wide hose range capacity		4
	M55 CUT	Stand type cutting machine	Aftermarket service and small-medium OEM workshop	Whole hose range capacity		5
	M75 CUT	Stand type cutting machine	Production unit	Whole hose range capacity		6
	M90 CUT	Stand type cutting machine	Production unit	Whole hose range capacity		7
SKIVING	MH SKY	Manual, portable skiving tool	Aftermarket service	Wide hose range capacity	M3	1
	M50 SKY	Benchtop, skiving	Aftermarket service	Wide hose range capacity		2
	M205 SKY	Stand type skive machine	Production unit	Whole hose range capacity		3
MARKING	M50 MARK	Benchtop, ferrules marking	Aftermarket service	Wide hose range capacity	M4	1
INSERT PUSHING	M1500 INS	Benchtop coupling inserter	Production unit	Whole hose range capacity	M5	1
TEST BENCH	MTB 1500	Stand type machine; proof pressure and certif.	Production unit	Wide hose range capacity	M6	1
	MTB 2500	Stand type machine; proof pressure and certif.	Production unit	Wide hose range capacity		2

# MODULAR ASSEMBLY UNITS

In order to simplify the process of selecting appropriate equipment for new workshops, Manuli Hydraulics also offers a range of scaled machine modules. These modules include suitable combinations of cutting and crimping machines (and skiving where appropriate), based on the scale and planned throughput of the intended assembly operation.

MODULE		DESCRIPTION	CAPACITY	CUTTING	SKIVING	CRIMPING	
M0	STATIC	Small Service Workshop	<ul style="list-style-type: none"> <li>• 1 1/4" 4WS</li> <li>• 25 Hoses / Day</li> <li>• Mixed sizes</li> </ul>	M22 CUT	M50 SKY	MB 137 PLUS	
	MOBILE			M22 CUT (12/24 V)	MH SKY	MV 137 (12/24V)	
M1	STATIC	Intermittent Service Workshop	<ul style="list-style-type: none"> <li>• 2" 4WS</li> <li>• 50 Hoses / Day</li> <li>• Mixed sizes</li> </ul>	M30 CUT & SKIVE		MB 240	
	MOBILE					MV 240 (12/24 V or 220 1Ph)	
M2	STATIC	Continuous Service Workshop	<ul style="list-style-type: none"> <li>• 2" 6WS - 3" 2WB</li> <li>• 100 Hoses / Day</li> <li>• Mixed sizes</li> </ul>	M55 CUT	M205 SKY PLUS	MB 350	
	MOBILE					MV 350 (12/24 V or 220 1Ph/3Ph) or GoldenCrimp/450	

# MODULAR ASSEMBLY UNITS

MODULE		DESCRIPTION	CAPACITY	CUTTING	SKIVING	CRIMPING	
P1	STATIC	OEM Assembly Workshop	<ul style="list-style-type: none"> <li>1 1/4" 4WS - 2" 2WB</li> <li>&gt;100 Hoses / Day</li> <li>Mixed sizes</li> </ul>	M55 CUT-P	M205 SKY	MS 280 L	
P2	STATIC	OEM Assembly Workshop	<ul style="list-style-type: none"> <li>2" 4WS - 3" 2WB</li> <li>&gt;100 Hoses / Day</li> <li>Mixed sizes</li> </ul>	M90 CUT	M205 SKY <i>(With reinforced clamping system)</i>	MS 320	
P3	STATIC	OEM Assembly Workshop	<ul style="list-style-type: none"> <li>2" 6WS - 3" 4WS</li> <li>&gt;100 Hoses / Day</li> <li>Mixed sizes</li> </ul>	M90 CUT	M205 SKY <i>(With reinforced clamping system)</i>	MS 480	
P4	STATIC	XXL Assembly Workshop	<ul style="list-style-type: none"> <li>3" 8WS - 4" 4WS - 8" Industrial Hose</li> <li>50 Hoses / Day</li> <li>Mixed sizes</li> </ul>	MDH 15 CUT	MDH 205 SKY	MS 800	

## Key

### M Maintenance Operations

Intended for small or medium aftermarket, repair service

### P Production Operations

Intended for small/medium/large OEM activity or large production aftermarket



# DIE SET INDEX

MODEL		DIE N°																												DIE SET PACKAGES	QTY	KIT	
		10	12	15	18	21	24	27	30	33	36	39	42	45	48	51	57	62	66	70	72	73	76	86	92	95	105	112	130				
MHP80	mm	56	56	56	56	56	56	56	56	-	-	56	-	-	-	-														ESA3110NH80KT	6		
	inch	2.205	2.205	2.205	2.205	2.205	2.205	2.205	2.205	2.205	-	-	2.205	-	-	-	-														ESA3110NH80KT	6	
MHP137	mm	56	56	56	56	56	56	56	56	70	75	70	70	70	70	75														ESA3220N137KT	10	KIT 10	
	inch	2.205	2.205	2.205	2.205	2.205	2.205	2.205	2.205	2.205	2.756	2.953	2.756	2.756	2.756	2.756	2.953													ESA3220NKT13JF	13	KIT 13	
MB 137 MV 137	mm	56	56	56	56	56	56	56	56	70	75	70	70	70	70	75														ESA3220N137KT	10	KIT 10	
	inch	2.205	2.205	2.205	2.205	2.205	2.205	2.205	2.205	2.205	2.756	2.953	2.756	2.756	2.756	2.756	2.953													ESA3220NKT13JF	13	KIT 13	
MB 240 MV 240	mm	56	56	56	56	56	70	90	90	90	90	90	90	100	100	100	100	100	100	100	100									ESA3320N240KT	12	KIT 12	
	inch	2.205	2.205	2.205	2.205	2.205	2.756	3.543	3.543	3.543	3.543	3.543	3.543	3.543	3.937	3.937	3.937	3.937	3.937	3.937	3.937	3.937									ESA3320N240KTF	18	KIT 18
MB 350 MV 350	mm	56	56	56	56	56	70	90	90	90	90	90	90	100	100	110	110	110	110	100	100	125	125		125	125				ESA3330N340KT	13	KIT 13	
	inch	2.205	2.205	2.205	2.205	2.205	2.756	3.543	3.543	3.543	3.543	3.543	3.543	3.543	3.937	3.937	4.331	4.331	4.331	4.331	3.937	3.937	4.921	4.921		4.921	4.921			ESA3330N340KTF	20	KIT 20	
GOLDENCRIMP 450	mm	56	56	56	56	56	70	90	90	90	90	90	90	100	100	110	110	110	110	100	100	125	125	150	125	150	150	150		ESA3330N450KT	13	KIT 13	
	inch	2.205	2.205	2.205	2.205	2.205	2.756	3.543	3.543	3.543	3.543	3.543	3.543	3.543	3.937	3.937	4.331	4.331	4.331	4.331	3.937	3.937	4.921	4.921	5.906	4.921	5.906	5.906	5.906		ESA3330N450KTF	20	KIT 20
MS140	mm	56	70	70	70	70	70	70	70	70	75	70	70	70	70	75														ESA3540N140KT	10	KIT 10	
	inch	2.205	2.756	2.756	2.756	2.756	2.756	2.756	2.756	2.756	2.756	2.953	2.756	2.756	2.756	2.953														ESA3540N140KTF	12	KIT 12	
MS280L	mm	56	56	56	56	56	70	90	90	90	90	90	90	100	100	100	100	110	100	100	100								-	18			
	inch	2.205	2.205	2.205	2.205	2.205	2.756	3.543	3.543	3.543	3.543	3.543	3.543	3.543	3.937	3.937	3.937	3.937	4.331	3.937	3.937	3.937								ESA3320N240KTF	18	KIT 18	
MS320	mm	90	90	90	90	90	90	90	90	90	90	90	90	95	100	110	110	110	110	100	100	120	120	-	125	125				ESA3540N320KT	13	KIT 13	
	inch	3.543	3.543	3.543	3.543	3.543	3.543	3.543	3.543	3.543	3.543	3.543	3.543	3.543	3.740	3.937	4.331	4.331	4.331	4.331	3.937	3.937	4.724	4.724		4.921	4.921			ESA3540N320KTF	20	KIT 20	
MS480	mm	90	90	90	90	90	90	90	100	90	90	90	90	100	100	110	110	110	110	100	100	125	125	150	125	150	150	150		ESA3540N480KT	13	KIT 13	
	inch	3.543	3.543	3.543	3.543	3.543	3.543	3.543	3.937	3.543	3.543	3.543	3.543	3.543	3.937	3.937	4.331	4.331	4.331	4.331	3.937	3.937	4.921	4.921	5.906	4.921	5.906	5.906	5.906		ESA3540N480KTF	20	KIT 20
MS800	mm			90	90	90	90	90	100	90		90	90	100	100	110	110	110	110	100	100	125	125	150	125	150	180	150	180		ESA3540N480KT	13	KIT 13
	inch			3.543	3.543	3.543	3.543	3.543	3.937	3.543		3.543	3.543	3.937	3.937	4.331	4.331	4.331	4.331	3.937	3.937	4.921	4.921	5.906	4.921	5.906	7.087	5.906	7.087		ESA3540N800KTF	18	KIT 18

- xx Die set standard package
- xx Die set full package
- xx Optional die sets
- xx Diamondspir die sets (optional)
- xx Master die



# CRIMPING MACHINES

## MHP 80

FIELD SERVICE & MOBILE WORKSHOP

HAND PUMP, PORTABLE



### KEY ADVANTAGES

- Compact
- Lightweight
- Easy to use
- Balanced design
- Dual stage pump

### MAIN APPLICATIONS

Dedicated to repair shops or maintenance departments making low volumes of small and medium sized hose assemblies. Also ideal for carrying out on-site repairs.

### TECHNICAL SPECIFICATIONS

<b>Dimensions:</b>	330 x 250 x 400 mm (13 x 10 x 16")	<b>Crimp Range:</b>	4 - 43 mm (0.157 - 1.693")
<b>Net Weight:</b>	28 kg (62 lb)	<b>Crimp Force:</b>	80 t
<b>Packaging:</b>	800 x 600 x 830 mm (31 x 24 x 33")	<b>Opening with Dies:</b>	+20 mm (+0.787")
<b>Gross Weight:</b>	41 kg (90 lb)	<b>Complete Opening:</b>	59 mm (2.323")
<b>Capacity:</b>	2wb: 1" max.	<b>Master Die Length:</b>	56 mm (2.205")
	4ws: 1/2" max.	<b>Standard Dies:</b>	15, 18, 21, 24, 27, 30, 39

#### Technical Features:

- Hand pump: 5000 psi (double speed)
- Options available: hydropneumatic pump

### HOSE AND FITTING SELECTION

Hose Type	Fittings Type	Max. Hose Size	Ref. Hoses
2 Wire Braid & Textile	MF2000 Multifit	1"	Tractor; Harvester; Lyteflex; Pilot; Cover; Equator; Rockmaster (braided); Shieldmaster (braided); Astro; Multitex; Hydroplast; Spirtex/K
4 Wire Spirals	MF2000 Multifit	1/2"	Rockmaster/12; Rockmaster/4SP; Shieldmaster 6000 (DN10 & DN12 spiral)

### ORDERING INFORMATION

Product Code	Description
EOA3110NMHP80	MHP 80 (NO DIES)
EOA3110NMHP80PPPM	MHP 80 MANUAL PUMP + PPPM

# CRIMPING MACHINES

## MHP 80

**FIELD SERVICE & MOBILE WORKSHOP**

**HAND PUMP, PORTABLE**

### AVAILABLE DIE SETS

Product Code	Description	N°	Crimp Range	Die Length (mm)	Die Length (inch)
ESA3110N80-06	Die set n. 06 - length 56 mm	6	06-08	56	2.205
ESA3220NL056D008L2	Die set n. 08 - length 56 mm	8	08-10	56	2.205
ESA3110N80-10	Die set n. 10 - length 56 mm	10	10-12	56	2.205
ESA3110N80-12	Die set n. 12 - length 56 mm	12	12-15	56	2.205
ESA3110N80-15	Die set n. 15 - length 56 mm	15	15-18	56	2.205
ESA3110N80-18	Die set n. 18 - length 56 mm	18	18-21	56	2.205
ESA3110N80-21	Die set n. 21 - length 56 mm	21	21-24	56	2.205
ESA3110N80-24	Die set n. 24 - length 56 mm	24	24-27	56	2.205
ESA3110N80-27	Die set n. 27 - length 56 mm	27	27-30	56	2.205
ESA3110N80-30	Die set n. 30 - length 56 mm	30	30-43	56	2.205
ESA3110NH80KT	Kit 6 dies MHP80/HCRIMP80 (n.15 to n.30)	-	-	-	-



# CRIMPING MACHINES

## MHP 137

FIELD SERVICE & MOBILE WORKSHOP

**HAND PUMP, PORTABLE**



### KEY ADVANTAGES

- High capacity
- Narrow head
- Audio-visual signal
- 350 bar technology more robust & reliable than 700 bar
- Large opening

### MAIN APPLICATIONS

Dedicated to repair shops or maintenance departments making low volumes of small and medium sized hose assemblies. Can also be used in a vehicle for on-site repairs.

### TECHNICAL SPECIFICATIONS

<b>Dimensions:</b>	480 x 250 x 340 mm (19 x 10 x 13")	<b>Crimp Range:</b>	4 - 70 mm (0.157 - 2.756")
<b>Net Weight:</b>	55 kg (121 lb)	<b>Crimp Force:</b>	137 t
<b>Packaging:</b>	800 x 600 x 830 mm (31 x 24 x 33")	<b>Opening with Dies:</b>	+28 mm (+1.102")
<b>Gross Weight:</b>	75 kg (165 lb)	<b>Complete Opening:</b>	100 mm (3.937")
<b>Capacity:</b>	2wb: 1 1/4" max. 4ws: 1 1/4" max.	<b>Master Die Length:</b>	75 mm (2.362")
<b>Technical Features:</b>	Options available: Hydropneumatic pump	<b>Standard Dies:</b>	15, 18, 21, 24, 27, 30, 33, 36, 39, 42, 45, 48, 51 and Refrifast dies 14, 18, 21

### HOSE AND FITTING SELECTION

Hose Type	Fittings Type	Max. Hose Size	Ref. Hoses
2 Wire Braid & Textile	MF2000 Multifit; MF3000 OPF; MF3000 OPK	1 1/4" (with extra dies 45/51)	Tractor; Harvester; Lyteflex; Pilot; Cover; Equator; Rockmaster (braided); Shieldmaster (braided); Astro; Multitex; Hydroplast; Spirtex/K
4 Wire Spirals	MF2000 Multifit; MF3000 OPF; MF3000 OPK	1 1/4" (with extra dies 45/51)	Rockmaster (spiral); Shieldmaster (spiral); GoldenISO Xtraflex
4 Wire Spirals	MF2000 Interlock Plus; MF2000 Xtralock	3/4"	Rockmaster (spiral); Shieldmaster (spiral); GoldenISO Xtraflex

### ORDERING INFORMATION

Product Code	Description
EOA3110NMHP137P2	MHP 137
EOA3110NMHP137PHP	MHP 137 HP
EOA3110NMHP137PHPM	MHP 137 HPM

# CRIMPING MACHINES

## MHP 137

**FIELD SERVICE & MOBILE WORKSHOP**

**HAND PUMP, PORTABLE**

### AVAILABLE DIE SETS

Product Code	Description	N°	Crimp Range	Die Length (mm)	Die Length (inch)
ESA3220NL56-6	Die set n. 6 - length 56 mm	6	06-08	56	2.205
ESA3220NL56-8	Die set n. 8 - length 56 mm	8	08-10	56	2.205
ESA3220NL56-10	Die set n. 10 - length 56 mm	10	10-12	56	2.205
ESA3220NL56-12	Die set n. 12 - length 56 mm	12	12-15	56	2.205
ESA3220NL56-15	Die set n. 15 - length 56 mm	15	15-18	56	2.205
ESA3220NL56-17	Die set n. 17 - length 56 mm	17	17-18	56	2.205
ESA3220NL56-18	Die set n. 18 - length 56 mm	18	18-21	56	2.205
ESA3220NL56-20	Die set n. 20 - length 56 mm	20	20-21	56	2.205
ESA3220NL56-21	Die set n. 21 - length 56 mm	21	21-24	56	2.205
ESA3220N137-24	Die set n. 24 - length 56 mm	24	24-27	56	2.205
ESA3220N137-27	Die set n. 27 - length 56 mm	27	27-30	56	2.205
ESA3220N137-30	Die set n. 30 - length 56 mm	30	30-33	56	2.205
ESA3220N137-33	Die set n. 33 - length 70 mm	33	33-36	70	2.756
ESA3220N75-36	Die set n. 36 - length 75 mm	36	36-39	75	2.953
ESA3220N137-39	Die set n. 39 - length 70 mm	39	39-42	70	2.756
ESA3320N140-42	Die set n. 42 - length 70 mm	42	42-45	70	2.756
ESA3220N137-45	Die set n. 45 - length 70 mm	45	45-48	70	2.756
ESA3220N137-48	Die set n. 48 - length 70 mm	48	48-51	70	2.756
ESA3220N137-51	Die set n. 51 - length 75 mm	51	51-57	75	2.953
ESA3220N137KT	Kit 10 dies MB137/S/MV137(n.15 to n.48)	-	-	-	-
ESA3220N137KT9J	Kit 9 dies MB137/S/MV137 (n.15 to n.48)	-	-	-	-
ESA3220NKIT6J	Kit 6 dies MB137/S/MV137 (n.15 to n.39)	-	-	-	-
ESA3220N137KTF	Kit 13 dies MB137/S/MV137(n.15 to n.51)	-	-	-	-

#### Notes:

*Refrigeration hose special dies available upon request*

# CRIMPING MACHINES



## MB 137 PLUS

SMALL SERVICE WORKSHOP (1 1/4" 4WS)

**BENCHTOP**

### KEY ADVANTAGES

- Compact, short head
- Micrometer and cylinder protection
- Large opening
- Die storage included
- Easy to move
- Accurate
- Easy die set up
- Ergonomic design

### MAIN APPLICATIONS

Dedicated to maintenance departments or repair shops, as well as hose distributors.

### TECHNICAL SPECIFICATIONS

<b>Dimensions:</b>	600 x 650 x 550 mm (24 x 26 x 22")	<b>Motor:</b>	2.2 kW
<b>Net Weight:</b>	120 kg (265 lb)	<b>Noise Level:</b>	72 dB A
<b>Packaging:</b>	800 x 600 x 830 mm (31 x 24 x 33")	<b>Crimp Range:</b>	4 - 70 mm (0.157 - 2.756")
<b>Gross Weight:</b>	130 kg (287 lb)	<b>Crimp Force:</b>	137 t
<b>Voltages:</b>	220/240 V, 3Ph, 50 Hz	<b>Opening with Dies:</b>	+28 mm (+1.102")
	380/415 V, 3Ph, 50 Hz	<b>Complete Opening:</b>	100 mm (3.937")
	208/240 V, 3Ph, 60 Hz	<b>Master Die Length:</b>	75 mm (2.953")
	380/415 V, 3Ph, 60 Hz	<b>Standard Dies:</b>	15, 18, 21, 24, 27, 30, 33
<b>Capacity:</b>	2wb: 1 1/4" max.		36, 39, 42, 45, 48, 51
	4ws: 1 1/4" max.	<b>Technical Features:</b>	Other voltages available on request

### HOSE AND FITTING SELECTION

Hose Type	Fittings Type	Max. Hose Size	Ref. Hoses
2 Wire Braid & Textile	MF2000 Multifit; MF3000 OPF; MF3000 OPK	1 1/4"	Tractor; Harvester; Lyteflex; Pilot; Cover; Equator; Rockmaster (braided); Shieldmaster (braided); Astro; Multitex; Hydroplast; Spirtex/K
4 Wire Spirals	MF2000 Multifit; MF3000 OPF; MF3000 OPK	1 1/4"	Rockmaster (spiral); Shieldmaster (spiral); GoldenISO Xtraflex
4 Wire Spirals	MF2000 Interlock Plus; MF2000 Xtralock	3/4"	Rockmaster (spiral); Shieldmaster (spiral); GoldenISO Xtraflex



Performances measured on a 400 V, 3Ph, 50 Hz network

# CRIMPING MACHINES

## MB 137 PLUS

SMALL WORKSHOP SERVICE (1¼" 4WS)

**BENCHTOP**

### ORDERING INFORMATION

Product Code	Description
EOA3224NMB137	MB 137+ 380/415V 3PH 50HZ
EOA3227NMB137	MB 137+ 220/240V 3PH 50HZ
EOA3229NMB137	MB 137+ 208/240V 3PH 60HZ
EOA322BNMB137	MB 137+ 380/415V 3PH 60HZ

### AVAILABLE DIE SETS

Product Code	Description	N°	Crimp Range	Die Length (mm)	Die Length (inch)
ESA3220NL56-6	Die set n. 6 - length 56 mm	6	06-08	56	2.205
ESA3220NL56-8	Die set n. 8 - length 56 mm	8	08-10	56	2.205
ESA3220NL56-10	Die set n. 10 - length 56 mm	10	10-12	56	2.205
ESA3220NL56-12	Die set n. 12 - length 56 mm	12	12-15	56	2.205
ESA3220NL56-15	Die set n. 15 - length 56 mm	15	15-18	56	2.205
ESA3220NL56-17	Die set n. 17 - length 56 mm	17	17-18	56	2.205
ESA3220NL56-18	Die set n. 18 - length 56 mm	18	18-21	56	2.205
ESA3220NL56-20	Die set n. 20 - length 56 mm	20	20-21	56	2.205
ESA3220NL56-21	Die set n. 21 - length 56 mm	21	21-24	56	2.205
ESA3220N137-24	Die set n. 24 - length 56 mm	24	24-27	56	2.205
ESA3220N137-27	Die set n. 27 - length 56 mm	27	27-30	56	2.205
ESA3220N137-30	Die set n. 30 - length 56 mm	30	30-33	56	2.205
ESA3220N137-33	Die set n. 33 - length 70 mm	33	33-36	70	2.756
ESA3220N75-36	Die set n. 36 - length 75 mm	36	36-39	75	2.953
ESA3220N137-39	Die set n. 39 - length 70 mm	39	39-42	70	2.756
ESA3320N140-42	Die set n. 42 - length 70 mm	42	42-45	70	2.756
ESA3220N137-45	Die set n. 45 - length 70 mm	45	45-48	70	2.756
ESA3220N137-48	Die set n. 48 - length 70 mm	48	48-51	70	2.756
ESA3220N137-51	Die set n. 51 - length 75 mm	51	51-57	75	2.953
ESA3220N137KT	Kit 10 dies MB137+/S/MV137(n.15 to n.48)	-	-	-	-
ESA3220N137KT9J	Kit 9 dies MB137+/S/MV137 (n.15 to n.48)	-	-	-	-
ESA3220NKIT6J	Kit 6 dies MB137+/S/MV137 (n.15 to n.39)	-	-	-	-
ESA3220N137KTF	Kit 13 dies MB137+/S/MV137(n.15 to n.51)	-	-	-	-

#### Notes:

*Refrigeration hose special dies available upon request*

# CRIMPING MACHINES

## MB 240

PROFESSIONAL WORKSHOP

**BENCHTOP**



### KEY ADVANTAGES

- Ergonomic micrometer
- Radial die movement
- High crimping force
- Electronic control including counters and semi-automatic opening
- Built-in safety system to prevent incorrect die choice
- Cylinder protection
- Easy front access for elbow fittings
- Energy savings

### MAIN APPLICATIONS

Dedicated to hydraulic maintenance specialists working on medium sized machines and equipment. Also suitable for assemblers involved in medium sized hoses and quantities.

### TECHNICAL SPECIFICATIONS

<b>Dimensions:</b>	1120 x 670 x 915 mm (44 x 26 x 36")	<b>Motor:</b>	4.0 kW
<b>Net Weight:</b>	190 kg (419 lb)	<b>Noise Level:</b>	66 dB A
<b>Packaging:</b>	1170 x 770 x 1100 mm (46 x 30 x 43")	<b>Crimp Range:</b>	4 - 76 mm (0.157 - 2.992")
<b>Gross Weight:</b>	234 kg (516 lb)	<b>Crimp Force:</b>	240 t
<b>Voltages:</b>	220/240 V, 3Ph, 50 Hz	<b>Opening with Dies:</b>	+38 mm (+1.496")
	380/415 V, 3Ph, 50 Hz	<b>Complete Opening:</b>	118 mm (4.645")
	208/240 V, 3Ph, 60 Hz	<b>Master Die Length:</b>	100 mm (3.937")
	380/415 V, 3Ph, 60 Hz	<b>Standard Dies:</b>	15, 18, 21, 24, 27, 30, 33, 36, 39, 42, 45, 48, 51, 57, 62, 66, 70, 72
<b>Capacity:</b>	2ws: 2" max.		
	4ws: 2" max.		
	6ws: 1" max.		

### HOSE AND FITTING SELECTION

Hose Type	Fittings Type	Max. Hose Size	Ref. Hoses
2 Wire Braid & Textile	MF2000 Multifit; MF3000 OPF; MF3000 OPK	2"	Tractor; Harvester; Lyteflex; Pilot; Cover; Equator; Rockmaster (braided); Shieldmaster (braided); Astro; Multitex; Hydroplast; Spirtex/K
4 Wire Spirals	MF2000 Multifit; MF3000 OPF; MF3000 OPK	2"	Rockmaster (spiral); Shieldmaster (spiral); GoldenISO Xtraflex
4 Wire Spirals	MF2000 Interlock Plus; MF2000 Xtralock; MF2000 Spiralfit	1 1/4"	Rockmaster (spiral); Shieldmaster (spiral); GoldenISO Xtraflex
6 Wire Spirals	MF2000 Interlock Plus; MF2000 Xtralock	1"	Diamondspir; Goldenblast/Six



Performances measured on a 400 V, 3Ph, 50 Hz network

# CRIMPING MACHINES

## MB 240

PROFESSIONAL WORKSHOP

**BENCHTOP**

### ORDERING INFORMATION

Product Code	Description
EOA3324NMB240P	MB 240 380/415V 3PH 50HZ
EOA3327NMB240P	MB 240 220/240V 3PH 50HZ
EOA3329NMB240P	MB 240 208/240V 3PH 60HZ
EOA332BNMB240P	MB 240 380/415V 3PH 60HZ

### AVAILABLE DIE SETS

Product Code	Description	N°	Crimp Range	Die Length (mm)	Die Length (inch)
ESA3220NL56-10	Die set n. 10 - length 56 mm	10	10-12	56	2.205
ESA3220NL56-12	Die set n. 12 - length 56 mm	12	12-15	56	2.205
ESA3220NL56-15	Die set n. 15 - length 56 mm	15	15-18	56	2.205
ESA3220NL56-18	Die set n. 18 - length 56 mm	18	18-21	56	2.205
ESA3220NL56-21	Die set n. 21 - length 56 mm	21	21-24	56	2.205
ESA3320N140-24	Die set n. 24 - length 70 mm	24	24-27	70	2.756
ESA3320NL90-27	Die set n. 27 - length 90 mm	27	27-30	90	3.543
ESA3320NL90-30	Die set n. 30 - length 90 mm	30	30-33	90	3.543
ESA3320NL90-33	Die set n. 33 - length 90 mm	33	33-36	90	3.543
ESA3320NL90-36	Die set n. 36 - length 90 mm	36	36-39	90	3.543
ESA3320NL90-39	Die set n. 39 - length 90 mm	39	39-42	90	3.543
ESA3320NL90-42	Die set n. 42 - length 90 mm	42	42-45	90	3.543
ESA3320N100-45	Die set n. 45 - length 100 mm	45	45-48	100	3.937
ESA3320NL100-48	Die set n. 48 - length 100 mm	48	48-51	100	3.937
ESA3320N100-51	Die set n. 51 - length 100 mm	51	51-57	100	3.937
ESA3320N100-54	Die set n. 54 - length 100 mm	54	54-57	100	3.937
ESA3320N100-57	Die set n. 57 - length 100 mm	57	57-62	100	3.937
ESA3320N100-62	Die set n. 62 - length 110 mm	62	62-66	110	4.331
ESA3320N100-66	Die set n. 66 - length 100 mm	66	66-70	100	3.937
ESA3320N100-70	Die set n. 70 - length 100 mm	70	70-72	100	3.937
ESA3330NL100D072L2	Die set n. 72 - length 100 mm	72	72-73	100	3.937
ESA3320N240KT	Kit 12 dies MB240/MV240 (n.15 to n.66)	-	-	-	-
ESA3320N240KTF	Kit 18 dies MB240/MV240 (n.15 to n.72)	-	-	-	-

#### Notes:

*Refrigeration hose special dies available upon request*

# CRIMPING MACHINES

## MB 350

FULL SERVICE WORKSHOP

**BENCHTOP; VERY HIGH CRIMP FORCE**



### KEY ADVANTAGES

- High power and large opening in a very compact design
- Radial die movement (easy positioning of fitting: no axial movement during crimping)
- Groove for 90° long drop fittings
- Energy savings (stop & start concept)
- Electronic control including counter and semi-automatic opening
- Easy set up with ergonomic, intuitive and precise micrometer

### MAIN APPLICATIONS

Dedicated to professional hydraulic maintenance specialists, professional service workshops, and large bore after-market hose assemblers.

### TECHNICAL SPECIFICATIONS

<b>Dimensions:</b>	1005 x 655 x 668 mm (40 x 26 x 26.5")	<b>Motor:</b>	5.5 kW
<b>Net Weight:</b>	290 kg (639 lb)	<b>Noise Level:</b>	<65 dB A
<b>Packaging:</b>	1170 x 760 x 1100 mm (46 x 30 x 43")	<b>Crimp Range:</b>	4 - 130 mm (0.157 - 5.118")
<b>Gross Weight:</b>	350 kg (772 lb)	<b>Crimp Force:</b>	350 t
<b>Voltages:</b>	220/240 V, 3Ph, 50 Hz	<b>Opening with Dies:</b>	+54 mm (+2.125")
	380/415 V, 3Ph, 50 Hz	<b>Complete Opening:</b>	180 mm (7.086")
	208/240 V, 3Ph, 60 Hz	<b>Master Die Length:</b>	115 mm (4.523")
	380/415 V, 3Ph, 60 Hz	<b>Standard Dies:</b>	15, 18, 21, 24, 27, 30, 33, 36, 39, 42, 45, 48, 51, 57, 62, 66, 70, 72, 73, 76
<b>Capacity:</b>	2wb: 3" max.	<b>Technical Features:</b>	- Automatic maintenance alerts - Cylinder protection against dust - durable design
	Textile / Suction Hose: 4" max.	<b>Safety remarks:</b>	Please consider hose-fitting-machine integration when crimping. Possible limitations in case of double elbow fittings.
	4ws: 2" max.		
	6ws: 2" max.		

### HOSE AND FITTING SELECTION

Hose Type	Fittings Type	Max. Hose Size	Ref. Hoses
2 Wire Braid & Textile	MF2000 Multifit; MF3000 OPF; MF3000 OPK	3" with extra dies	Tractor; Harvester; Lyteflex; Pilot; Cover; Equator; Rockmaster (braided); Shieldmaster (braided); Astro; Multitex; Hydroplast; Spirtex/K
4 Wire Spirals	MF2000 Multifit; MF2000 Interlock Plus; MF2000 Spiralfit; MF3000 OPF; MF3000 OPK	2"	Rockmaster (spiral); Shieldmaster (spiral); GoldenISO Xtraflex; Goldenblast
6 Wire Spirals	MF2000 Interlock Plus; MF2000 Spiralfit	2"	Rockmaster/13; GoldenIso/35 Xtraflex; Goldenblast
6 Wire Spirals	MF2000 Interlock Plus; MF2000 Spiralfit; MF2000 Xtralock	1½"	Diamondspir; Rockmaster/15; GoldenISO/42 Xtraflex; Shieldmaster/6000



Performances measured on a 400 V, 3Ph, 50 Hz network

# CRIMPING MACHINES

## MB 350

**FULL SERVICE WORKSHOP**

**BENCHTOP, VERY HIGH CRIMP FORCE**

### ORDERING INFORMATION

Product Code	Description
EOA3324NMB350P	MB 350+380/415V 3PH 50HZ
EOA3334NMB350SCS	MB 350 380/415V 3PH 50HZ 5.5KW
EOA3327NMB350P	MB 350 220/240V 3PH 50HZ
EOA3337NMB350SCS	MB 350 220/240V 3PH 50HZ 5.5KW
EOA3329NMB350P	MB 350 208/240V 3PH 60HZ
EOA3339NMB350SCS	MB 350 208/240V 3PH 60HZ 5.5KW
EOA332BNMB350P	MB 350 380/415V 3PH 60HZ

### AVAILABLE DIE SETS

Product Code	Description	N°	Crimp Range	Die Length (mm)	Die Length (inch)
ESA3220NL56-10	Die set n. 10 - length 56 mm	10	10-12	56	2.205
ESA3220NL56-12	Die set n. 12 - length 56 mm	12	12-15	56	2.205
ESA3220NL56-15	Die set n. 15 - length 56 mm	15	15-18	56	2.205
ESA3220NL56-18	Die set n. 18 - length 56 mm	18	18-21	56	2.205
ESA3220NL56-21	Die set n. 21 - length 56 mm	21	21-24	56	2.205
ESA3320N140-24	Die set n. 24 - length 70 mm	24	24-27	70	2.756
ESA3320NL90-27	Die set n. 27 - length 90 mm	27	27-30	90	3.543
ESA3320NL90-30	Die set n. 30 - length 90 mm	30	30-33	90	3.543
ESA3320NL90-33	Die set n. 33 - length 90 mm	33	33-36	90	3.543
ESA3320NL90-36	Die set n. 36 - length 90 mm	36	36-39	90	3.543
ESA3320NL90-39	Die set n. 39 - length 90 mm	39	39-42	90	3.543
ESA3320NL90-42	Die set n. 42 - length 90 mm	42	42-45	90	3.543
ESA3320N100-45	Die set n. 45 - length 100 mm	45	45-48	100	3.937
ESA3320NL100-48	Die set n. 48 - length 100 mm	48	48-51	100	3.937
ESA3320N110-51	Die set n. 51 - length 110 mm	51	51-57	110	4.331
ESA3320N110-57	Die set n. 57 - length 110 mm	57	57-62	110	4.331
ESA3320N110-62	Die set n. 62 - length 110 mm	62	62-66	110	4.331
ESA3330N125-66	Die set n. 66 - length 110 mm	66	66-70	110	4.331
ESA3320N100-70	Die set n. 70 - length 100 mm	70	70-72	100	3.937
ESA3330NL100D072L2	Die set n. 72 - length 100 mm	72	72-73	100	3.937
ESA3540N125-73	Die set n. 73 - length 125 mm	73	73-76	125	4.921
ESA3540N125-76A	Die set n. 76 - length 125 mm	76	76-86	125	4.921
ESA3540N125-90	Die set n. 90 - length 125 mm	90	90-95	125	4.921
ESA3540N12595	Die set n. 95 - length 125 mm	95	95-105	125	4.921
ESA3330N340KT	Kit 13 dies MB350/L/MV350 (n.15 to n.73)	-	-	-	-
ESA3330N340KTF	Kit 20 dies MB350/L/MV350 (n.15 to n.76)	-	-	-	-

#### Notes:

*Refrigeration hose special dies available upon request*



# CRIMPING MACHINES

## MB 350 L

FULL SERVICE WORKSHOP

**BENCHTOP; VERY HIGH CRIMP FORCE**



### KEY ADVANTAGES

- High power and large opening in a very compact design
- Radial die movement (easy positioning of fitting: no axial movement during crimping)
- Groove for 90° long drop fittings
- Energy savings (stop & start concept)
- Electronic control including counter and semi-automatic opening
- Easy set up with ergonomic, intuitive and precise micrometer

### MAIN APPLICATIONS

Dedicated to professional hydraulic maintenance specialists, professional service workshops, and large bore after-market hose assemblers.

### TECHNICAL SPECIFICATIONS

**Dimensions:** 1005 x 655 x 668 mm (40 x 26 x 26.5")  
**Net Weight:** 260 kg (573 lb)  
**Packaging:** 1170 x 760 x 1100 mm (46 x 30 x 43")  
**Gross Weight:** 350 kg (772 lb)  
**Voltages:** 220/240 V, 3Ph, 50 Hz  
 380/415 V, 3Ph, 50 Hz  
 208/240 V, 3Ph, 60 Hz  
 380/415 V, 3Ph, 60 Hz  
**Capacity:** 2wb: 3" max.  
 Textile / Suction Hose: 4" max.  
 4ws: 2" max.  
 6ws: 1½" max.

**Motor:** 4.0 kW  
**Noise Level:** <65 dB A  
**Crimp Range:** 4 - 130 mm (0.157 - 5.118")  
**Crimp Force:** 350 t  
**Opening with Dies:** +54 mm (+2.125")  
**Complete Opening:** 180 mm (7.086")  
**Master Die Length:** 115 mm (4.523")  
**Standard Dies:** 15, 18, 21, 24, 27, 30, 33, 36, 39, 42,  
 45, 48, 51, 57, 62, 66, 70, 72, 73, 76

#### Technical Features:

- Automatic maintenance alerts
- Cylinder protection against dust (durable design)

#### Safety Remarks:

Please consider hose-fitting-machine integration when crimping. Possible limitations in case of double elbow fittings.

### HOSE AND FITTING SELECTION

Hose Type	Fittings Type	Max. Hose Size	Ref. Hoses
2 Wire Braid & Textile	MF2000 Multifit; MF3000 OPF; MF3000 OPK	3" with extra dies	Tractor; Harvester; Lyteflex; Pilot; Cover; Equator; Rockmaster (braided); Shieldmaster (braided); Astro; Multitex; Hydroplast; Spirtex/K
4 Wire Spirals	MF2000 Multifit; MF2000 Interlock Plus; MF2000 Xtralock; MF2000 Spiralfit; MF3000 OPF; MF3000 OPK	2"	Rockmaster (spiral); Shieldmaster (spiral); GoldenISO Xtraflex; Goldenblast
6 Wire Spirals	MF2000 Interlock Plus; MF2000 Xtralock; MF2000 Spiralfit	1½"	Rockmaster/13; Rockmaster/15; GoldenISO/35 Xtraflex; GoldenISO/42 Xtraflex; Diamondspir; Shieldmaster/6000; Goldenblast/six



Performances measured on a 400 V, 3Ph, 50 Hz network

# CRIMPING MACHINES

## MB 350 L

FULL SERVICE WORKSHOP

**BENCHTOP; VERY HIGH CRIMP FORCE**

### ORDERING INFORMATION

Product Code	Description
EOA3324NMB350LP	MB 350 L 380/415V 3PH 50HZ
EOA3327NMB350LP	MB 350 L 220/240V 3PH 50HZ
EOA3329NMB350LP	MB 350 L 208/240V 3PH 60HZ
EOA332BNMB350LP	MB 350 L 380/415V 3PH 60HZ

### AVAILABLE DIE SETS

Product Code	Description	N°	Crimp Range	Die Length (mm)	Die Length (inch)
ESA3220NL56-10	Die set n. 10 - length 56 mm	10	10-12	56	2.205
ESA3220NL56-12	Die set n. 12 - length 56 mm	12	12-15	56	2.205
ESA3220NL56-15	Die set n. 15 - length 56 mm	15	15-18	56	2.205
ESA3220NL56-18	Die set n. 18 - length 56 mm	18	18-21	56	2.205
ESA3220NL56-21	Die set n. 21 - length 56 mm	21	21-24	56	2.205
ESA3320N140-24	Die set n. 24 - length 70 mm	24	24-27	70	2.756
ESA3320NL90-27	Die set n. 27 - length 90 mm	27	27-30	90	3.543
ESA3320NL90-30	Die set n. 30 - length 90 mm	30	30-33	90	3.543
ESA3320NL90-33	Die set n. 33 - length 90 mm	33	33-36	90	3.543
ESA3320NL90-36	Die set n. 36 - length 90 mm	36	36-39	90	3.543
ESA3320NL90-39	Die set n. 39 - length 90 mm	39	39-42	90	3.543
ESA3320NL90-42	Die set n. 42 - length 90 mm	42	42-45	90	3.543
ESA3320N100-45	Die set n. 45 - length 100 mm	45	45-48	100	3.937
ESA3320NL100-48	Die set n. 48 - length 100 mm	48	48-51	100	3.937
ESA3320N110-51	Die set n. 51 - length 110 mm	51	51-57	110	4.331
ESA3320N110-57	Die set n. 57 - length 110 mm	57	57-62	110	4.331
ESA3320N110-62	Die set n. 62 - length 110 mm	62	62-66	110	4.331
ESA3330N125-66	Die set n. 66 - length 110 mm	66	66-70	110	4.331
ESA3320N100-70	Die set n. 70 - length 100 mm	70	70-72	100	3.937
ESA3330NL100D072L2	Die set n. 72 - length 100 mm	72	72-73	100	3.937
ESA3540N125-73	Die set n. 73 - length 125 mm	73	73-76	125	4.921
ESA3540N125-76A	Die set n. 76 - length 125 mm	76	76-86	125	4.921
ESA3540N125-86	Die set n. 86 - length 125 mm	86	86-90	125	4.921
ESA3540N125-90	Die set n. 90 - length 125 mm	90	90-95	125	4.921
ESA3540N12595	Die set n. 95 - length 125 mm	95	95-105	125	4.921
ESA3330N340KT	Kit 13 dies MB350/L/MV350 (n.15 to n.73)	-	-	-	-
ESA3330N340KTF	Kit 20 dies MB350/L/MV350 (n.15 to n.76)	-	-	-	-

#### Notes:

*Refrigeration hose special dies available upon request*

# CRIMPING MACHINES

## MV 137

FIELD SERVICE & MOBILE WORKSHOP

MOBILE VAN

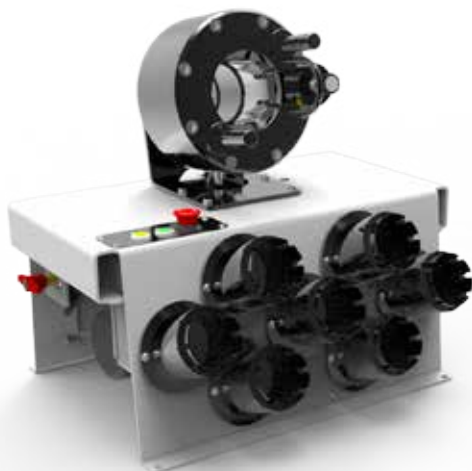

### KEY ADVANTAGES

- Robust and compact design
- Lightweight
- High crimping speed
- Suitable also for 90° elbow fittings
- Cylinder protection
- Remote head mounting option possible

### MAIN APPLICATIONS

Designed for hydraulic maintenance specialists for on-site repairs with mobile vans. It is possible to install the crimp head separately from the power pack to gain space inside the vehicle and obtain a lower centre of gravity.

### TECHNICAL SPECIFICATIONS

<b>Dimensions:</b>	650 x 550 x 610 mm (26 x 22 x 24")	<b>Motor:</b>	2.0 kW
<b>Net Weight:</b>	103 kg (227 lb)	<b>Noise Level:</b>	72 dB A
<b>Packaging:</b>	800 x 600 x 830 mm (31 x 24 x 33")	<b>Crimp Range:</b>	4 - 70 mm (0.157 - 2.756")
<b>Gross Weight:</b>	120 kg (265 lb)	<b>Crimp Force:</b>	137 t
<b>Voltages:</b>	12 V	<b>Opening with Dies:</b>	+28 mm (+1.102")
	24 V	<b>Complete Opening:</b>	100 mm (3.937")
<b>Capacity:</b>	2wb: 1 1/4" max.	<b>Master Die Length:</b>	75 mm (2.952")
	4ws: 1 1/4" max.	<b>Standard Dies:</b>	15, 18, 21, 24, 27, 30, 33, 36, 39, 42, 45, 48, 51

#### Technical Features:

Options available: Die storage, ergonomic gun, battery and charger, die sets for brake and air-conditioning hoses, marking dies

### HOSE AND FITTING SELECTION

Hose Type	Fittings Type	Max. Hose Size	Ref. Hoses
2 Wire Braid & Textile	MF2000 Multifit; MF3000 OPF; MF3000 OPK	1 1/4"	Tractor; Harvester; Lyteflex; Pilot; Cover; Equator; Rockmaster (braided); Shieldmaster (braided); Astro; Multitex; Hydroplast; Spirtex/K
4 Wire Spirals	MF2000 Multifit; MF3000 OPF; MF3000 OPK	1 1/4"	Rockmaster (spiral); Shieldmaster (spiral); GoldenISO Xtraflex
4 Wire Spirals	MF2000 Interlock Plus; MF2000 Xtralock	3/4"	Rockmaster (spiral); Shieldmaster (spiral); GoldenISO Xtraflex

# CRIMPING MACHINES

## MV 137

FIELD SERVICE & MOBILE WORKSHOP

MOBILE VAN

### ORDERING INFORMATION

Product Code	Description
EOA3251N12137	MV 137 12V
EOA3252N24137	MV 137 24V

### AVAILABLE DIE SETS

Product Code	Description	N°	Crimp Range	Die Length (mm)	Die Length (inch)
ESA3220NL56-6	Die set n. 6 - length 56 mm	6	06-08	56	2.205
ESA3220NL56-8	Die set n. 8 - length 56 mm	8	08-10	56	2.205
ESA3220NL56-10	Die set n. 10 - length 56 mm	10	10-12	56	2.205
ESA3220NL56-12	Die set n. 12 - length 56 mm	12	12-15	56	2.205
ESA3220NL56-15	Die set n. 15 - length 56 mm	15	15-18	56	2.205
ESA3220NL56-17	Die set n. 17 - length 56 mm	17	17-18	56	2.205
ESA3220NL56-18	Die set n. 18 - length 56 mm	18	18-21	56	2.205
ESA3220NL56-20	Die set n. 20 - length 56 mm	20	20-21	56	2.205
ESA3220NL56-21	Die set n. 21 - length 56 mm	21	21-24	56	2.205
ESA3220N137-24	Die set n. 24 - length 56 mm	24	24-27	56	2.205
ESA3220N137-27	Die set n. 27 - length 56 mm	27	27-30	56	2.205
ESA3220N137-30	Die set n. 30 - length 56 mm	30	30-33	56	2.205
ESA3220N137-33	Die set n. 33 - length 70 mm	33	33-36	70	2.756
ESA3220N75-36	Die set n. 36 - length 75 mm	36	36-39	75	2.953
ESA3220N137-39	Die set n. 39 - length 70 mm	39	39-42	70	2.756
ESA3320N140-42	Die set n. 42 - length 70 mm	42	42-45	70	2.756
ESA3220N137-45	Die set n. 45 - length 70 mm	45	45-48	70	2.756
ESA3220N137-48	Die set n. 48 - length 70 mm	48	48-51	70	2.756
ESA3220N137-51	Die set n. 51 - length 75 mm	51	51-57	75	2.953
ESA3220N137KT	Kit 10 dies MB137/S/MV137(n.15 to n.48)	-	-	-	-
ESA3220N137KT9J	Kit 9 dies MB137/S/MV137 (n.15 to n.48)	-	-	-	-
ESA3220NKIT6J	Kit 6 dies MB137/S/MV137 (n.15 to n.39)	-	-	-	-
ESA3220N137KTF	Kit 13 dies MB137/S/MV137(n.15 to n.51)	-	-	-	-

#### Notes:

*Refrigeration hose special dies available upon request*

# CRIMPING MACHINES



## MV 137 L

FIELD SERVICE & MOBILE WORKSHOP

MOBILE VAN

### KEY ADVANTAGES

- Robust and compact design
- Lightweight
- High crimping speed
- Suitable also for 90° elbow fittings
- Cylinder protection

### MAIN APPLICATIONS

Designed for hydraulic maintenance specialists for on-site repairs with mobile vans. It is possible to install the crimp head separately from the power pack to gain space inside the vehicle and obtain a lower centre of gravity. This machine is equipped with a cable remote control.

### TECHNICAL SPECIFICATIONS

<b>Dimensions:</b>	250 x 320 x 300 mm (10 x 13 x 12")	<b>Crimp Range:</b>	4 - 70 mm (0.157 - 2.756")
<b>Net Weight:</b>	86 kg (190 lb)	<b>Crimp Force:</b>	137 t
<b>Packaging:</b>	800 x 600 x 830 mm (31 x 24 x 33")	<b>Opening with Dies:</b>	+28 mm (+1.102")
<b>Gross Weight:</b>	102 kg (225 lb)	<b>Complete Opening:</b>	100 mm (3.937")
<b>Voltages:</b>	12 V	<b>Master Die Length:</b>	75 mm (2.952")
	24 V	<b>Standard Dies:</b>	15, 18, 21, 24, 27, 30, 33, 36, 39, 42, 45, 48, 51
<b>Capacity:</b>	2wb: 1 1/4" max. 4ws: 1 1/4" max.	<b>Technical Features:</b>	- Options available: Die storage, ergonomic gun, battery and charger, die sets for brake and air-conditioning hoses, marking dies - Dimensions of power pack: 440 x 320 x 320 mm (17 x 13 x 13")
<b>Motor:</b>	2.0 kW		
<b>Noise Level:</b>	72 dB A		

### HOSE AND FITTING SELECTION

Hose Type	Fittings Type	Max. Hose Size	Ref. Hoses
2 Wire Braid & Textile	MF2000 Multifit; MF3000 OPF; MF3000 OPK	1 1/4"	Tractor; Harvester; Lyteflex; Pilot; Cover; Equator; Rockmaster (braided); Shieldmaster (braided); Astro; Multitex; Hydroplast; Spirtex/K
4 Wire Spirals	MF2000 Multifit; MF3000 OPF; MF3000 OPK	1 1/4"	Rockmaster (spiral); Shieldmaster (spiral); GoldenISO Xtraflex
4 Wire Spirals	MF2000 Interlock Plus; MF2000 Xtralock	3/4"	Rockmaster (spiral); Shieldmaster (spiral); GoldenISO Xtraflex

# CRIMPING MACHINES

## MV 137 L

FIELD SERVICE & MOBILE WORKSHOP

MOBILE VAN

### ORDERING INFORMATION

Product Code	Description
EOA3251NMV137L	MV 137 L 12V
EOA3252NMV137L	MV 137 L 24V

### AVAILABLE DIE SETS

Product Code	Description	N°	Crimp Range	Die Length (mm)	Die Length (inch)
ESA3220NL56-6	Die set n. 6 - length 56 mm	6	06-08	56	2.205
ESA3220NL56-8	Die set n. 8 - length 56 mm	8	08-10	56	2.205
ESA3220NL56-10	Die set n. 10 - length 56 mm	10	10-12	56	2.205
ESA3220NL56-12	Die set n. 12 - length 56 mm	12	12-15	56	2.205
ESA3220NL56-15	Die set n. 15 - length 56 mm	15	15-18	56	2.205
ESA3220NL56-17	Die set n. 17 - length 56 mm	17	17-18	56	2.205
ESA3220NL56-18	Die set n. 18 - length 56 mm	18	18-21	56	2.205
ESA3220NL56-20	Die set n. 20 - length 56 mm	20	20-21	56	2.205
ESA3220NL56-21	Die set n. 21 - length 56 mm	21	21-24	56	2.205
ESA3220N137-24	Die set n. 24 - length 56 mm	24	24-27	56	2.205
ESA3220N137-27	Die set n. 27 - length 56 mm	27	27-30	56	2.205
ESA3220N137-30	Die set n. 30 - length 56 mm	30	30-33	56	2.205
ESA3220N137-33	Die set n. 33 - length 70 mm	33	33-36	70	2.756
ESA3220N75-36	Die set n. 36 - length 75 mm	36	36-39	75	2.953
ESA3220N137-39	Die set n. 39 - length 70 mm	39	39-42	70	2.756
ESA3320N140-42	Die set n. 42 - length 70 mm	42	42-45	70	2.756
ESA3220N137-45	Die set n. 45 - length 70 mm	45	45-48	70	2.756
ESA3220N137-48	Die set n. 48 - length 70 mm	48	48-51	70	2.756
ESA3220N137-51	Die set n. 51 - length 75 mm	51	51-57	75	2.953
ESA3220N137KT	Kit 10 dies MB137/S/MV137 (n.15 to n.48)	-	-	-	-
ESA3220N137KT9J	Kit 9 dies MB137/S/MV137 (n.15 to n.48)	-	-	-	-
ESA3220NKIT6J	Kit 6 dies MB137/S/MV137 (n.15 to n.39)	-	-	-	-
ESA3220N137KTF	Kit 13 dies MB137/S/MV137 (n.15 to n.51)	-	-	-	-

#### Notes:

*Refrigeration hose special dies available upon request*

# CRIMPING MACHINES

**MV 240**

**FIELD SERVICE & MOBILE WORKSHOP**

**MOBILE VAN**



## KEY ADVANTAGES

- Robust design
- Ergonomic micrometer
- High crimping speed
- Radial movement of the dies
- Cylinder protection
- Remote head mounting option possible

## MAIN APPLICATIONS

Designed for hydraulic maintenance specialists for on-site repairs with mobile vans. It is possible to install the crimp head separately from the power pack to gain space inside the vehicle and obtain a lower centre of gravity.

## TECHNICAL SPECIFICATIONS

<b>Dimensions:</b>	650 x 550 x 670 mm (26 x 22 x 26")	<b>Motor:</b>	2.0 kW
<b>Net Weight:</b>	145 kg (320 lb)	<b>Noise Level:</b>	72 dB A
<b>Packaging:</b>	800 x 600 x 830 mm (31 x 24 x 33")	<b>Crimp Range:</b>	4 - 76 mm (0.157 - 2.992")
<b>Gross Weight:</b>	180 kg (397 lb)	<b>Crimp Force:</b>	240 t
<b>Voltages:</b>	12 V	<b>Opening with Dies:</b>	+38 mm (+1.496")
	24 V	<b>Complete Opening:</b>	118 mm (4.646")
	220/240 V, 3Ph, 50 Hz	<b>Master Die Length:</b>	100 mm (3.937")
	380/415 V, 3Ph, 50 Hz	<b>Standard Dies:</b>	15, 18, 21, 24, 27, 30, 33, 36, 39,
	208/240 V, 3Ph, 60 Hz		42, 45, 48, 51, 57, 62, 66, 70, 72
	380/415 V, 3Ph, 60 Hz	<b>Technical Features:</b>	
<b>Capacity:</b>	2ws: 2" max.	Options available: Die storage, ergonomic gun, battery and charger, die sets for brake and air-conditioning hoses, marking dies	
	4ws: 2" max.		
	6ws: 1" max.		

## HOSE AND FITTING SELECTION

Hose Type	Fittings Type	Max. Hose Size	Ref. Hoses
2 Wire Braid & Textile	MF2000 Multifit; MF3000 OPF; MF3000 OPK	2"	Tractor; Harvester; Lyteflex; Pilot; Cover; Equator; Rockmaster (braided); Shieldmaster (braided); Astro; Multitex; Hydroplast; Spirtex/K
4 Wire Spirals	MF2000 Multifit; MF3000 OPF; MF3000 OPK	2"	Rockmaster (spiral); Shieldmaster (spiral); GoldenISO Xtraflex
4 Wire Spirals	MF2000 Interlock Plus; MF2000 Xtralock; MF2000 Spiralfit	1¼"	Rockmaster (spiral); Shieldmaster (spiral); GoldenISO Xtraflex
6 Wire Spirals	MF2000 Interlock Plus; MF2000 Xtralock	1"	Diamondspir; Goldenblast/Six

# CRIMPING MACHINES

## MV 240

FIELD SERVICE & MOBILE WORKSHOP

MOBILE VAN

### ORDERING INFORMATION

Product Code	Description
EOA3351N12240	MV 240 12V
EOA3352N24240	MV 240 24V
EOA3324NMV240	MV 240 380/415V 3PH 50HZ
EOA3327NMV240	MV 240 220/240V 3PH 50HZ
EOA3329NMV240	MV 240 208/240V 3PH 60HZ
EOA332BNMV240	MV 240 380/415V 3PH 60HZ

### AVAILABLE DIE SETS

Product Code	Description	N°	Crimp Range	Die Length (mm)	Die Length (inch)
ESA3220NL56-10	Die set n. 10 - length 56 mm	10	10-12	56	2.205
ESA3220NL56-12	Die set n. 12 - length 56 mm	12	12-15	56	2.205
ESA3220NL56-15	Die set n. 15 - length 56 mm	15	15-18	56	2.205
ESA3220NL56-18	Die set n. 18 - length 56 mm	18	18-21	56	2.205
ESA3220NL56-21	Die set n. 21 - length 56 mm	21	21-24	56	2.205
ESA3320N140-24	Die set n. 24 - length 70 mm	24	24-27	70	2.756
ESA3320NL90-27	Die set n. 27 - length 90 mm	27	27-30	90	3.543
ESA3320NL90-30	Die set n. 30 - length 90 mm	30	30-33	90	3.543
ESA3320NL90-33	Die set n. 33 - length 90 mm	33	33-36	90	3.543
ESA3320NL90-36	Die set n. 36 - length 90 mm	36	36-39	90	3.543
ESA3320NL90-39	Die set n. 39 - length 90 mm	39	39-42	90	3.543
ESA3320NL90-42	Die set n. 42 - length 90 mm	42	42-45	90	3.543
ESA3320N100-45	Die set n. 45 - length 100 mm	45	45-48	100	3.937
ESA3320NL100-48	Die set n. 48 - length 100 mm	48	48-51	100	3.937
ESA3320N100-51	Die set n. 51 - length 100 mm	51	51-57	100	3.937
ESA3320N100-54	Die set n. 54 - length 100 mm	54	54-57	100	3.937
ESA3320N100-57	Die set n. 57 - length 100 mm	57	57-62	100	3.937
ESA3320N100-62	Die set n. 62 - length 100 mm	62	62-66	110	4.331
ESA3320N100-66	Die set n. 66 - length 100 mm	66	66-70	100	3.937
ESA3320N100-70	Die set n. 70 - length 100 mm	70	70-72	100	3.937
ESA3330NL100D072L2	Die set n. 72 - length 100 mm	72	72-73	100	3.937
ESA3320N240KT	Kit 12 dies MB240/MV240 (n.15 to n.66)	-	-	-	-
ESA3320N240KTF	Kit 18 dies MB240/MV240 (n.15 to n.72)	-	-	-	-

#### Notes:

Refrigeration hose special dies available upon request



# CRIMPING MACHINES

## MV 240 L

FIELD SERVICE & MOBILE WORKSHOP

MOBILE VAN



### KEY ADVANTAGES

- Robust design
- Ergonomic micrometer
- High crimping speed
- Radial movement of the dies
- Cylinder protection

### MAIN APPLICATIONS

Designed for hydraulic maintenance specialists for on-site repairs with mobile vans. It is possible to install the crimp head separately from the power pack to gain space inside the vehicle and obtain a lower centre of gravity. This machine is equipped with a cable remote control.

### TECHNICAL SPECIFICATIONS

<b>Dimensions:</b>	320 x 360 x 350 mm (13 x 13.5 x 14")	<b>Motor:</b>	2.0 kW
<b>Net Weight:</b>	130 kg (287 lb)	<b>Noise Level:</b>	72 dB A
<b>Packaging:</b>	800 x 600 x 830 mm (31 x 24 x 33")	<b>Crimp Range:</b>	4 - 76 mm (0.157 - 2.992")
<b>Gross Weight:</b>	180 kg (397 lb)	<b>Crimp Force:</b>	240 t
<b>Voltages:</b>	12 V	<b>Opening with Dies:</b>	+38 mm (+1.496")
	24 V	<b>Complete Opening:</b>	118 mm (4.646")
	220/240 V, 3Ph, 50 Hz	<b>Master Die Length:</b>	100 mm (3.937")
	380/415 V, 3Ph, 50 Hz	<b>Standard Dies:</b>	15, 18, 21, 24, 27, 30, 33, 36, 39,
	208/240 V, 3Ph, 60 Hz		42, 45, 48, 51, 57, 62, 66, 70, 72
	380/415 V, 3Ph, 60 Hz	<b>Technical Features:</b>	
<b>Capacity:</b>	2wb: 2" max.	- Options available: Die storage, ergonomic gun, battery and charger, die sets for brake and air-conditioning hoses, marking dies	
	4ws: 2" max.	- Dimensions of power pack: 440 x 320 x 320 mm (17 x 13 x 13")	
	6ws: 1" max.		

### HOSE AND FITTING SELECTION

Hose Type	Fittings Type	Max. Hose Size	Ref. Hoses
2 Wire Braid & Textile	MF2000 Multifit; MF3000 OPF; MF3000 OPK	2"	Tractor; Harvester; Lyteflex; Pilot; Cover; Equator; Rockmaster (braided); Shieldmaster (braided); Astro; Multitex; Hydroplast; Spirtex/K
4 Wire Spirals	MF2000 Multifit; MF3000 OPF; MF3000 OPK	2"	Rockmaster (spiral); Shieldmaster (spiral); GoldenISO Xtraflex
4 Wire Spirals	MF2000 Interlock Plus; MF2000 Xtralock; MF2000 Spiralfit	1 1/4"	Rockmaster (spiral); Shieldmaster (spiral); GoldenISO Xtraflex
6 Wire Spirals	MF2000 Interlock Plus; MF2000 Xtralock	1"	Diamondspir; Goldenblast/Six

# CRIMPING MACHINES

## MV 240 L

FIELD SERVICE & MOBILE WORKSHOP

MOBILE VAN

### ORDERING INFORMATION

Product Code	Description
EOA3251NMV240L	MV 240 L 12V

### AVAILABLE DIE SETS

Product Code	Description	N°	Crimp Range	Die Length (mm)	Die Length (inch)
ESA3220NL56-10	Die set n. 10 - length 56 mm	10	10-12	56	2.205
ESA3220NL56-12	Die set n. 12 - length 56 mm	12	12-15	56	2.205
ESA3220NL56-15	Die set n. 15 - length 56 mm	15	15-18	56	2.205
ESA3220NL56-18	Die set n. 18 - length 56 mm	18	18-21	56	2.205
ESA3220NL56-21	Die set n. 21 - length 56 mm	21	21-24	56	2.205
ESA3320N140-24	Die set n. 24 - length 70 mm	24	24-27	70	2.756
ESA3320NL90-27	Die set n. 27 - length 90 mm	27	27-30	90	3.543
ESA3320NL90-30	Die set n. 30 - length 90 mm	30	30-33	90	3.543
ESA3320NL90-33	Die set n. 33 - length 90 mm	33	33-36	90	3.543
ESA3320NL90-36	Die set n. 36 - length 90 mm	36	36-39	90	3.543
ESA3320NL90-39	Die set n. 39 - length 90 mm	39	39-42	90	3.543
ESA3320NL90-42	Die set n. 42 - length 90 mm	42	42-45	90	3.543
ESA3320N100-45	Die set n. 45 - length 100 mm	45	45-48	100	3.937
ESA3320NL100-48	Die set n. 48 - length 100 mm	48	48-51	100	3.937
ESA3320N100-51	Die set n. 51 - length 100 mm	51	51-57	100	3.937
ESA3320N100-54	Die set n. 54 - length 100 mm	54	54-57	100	3.937
ESA3320N100-57	Die set n. 57 - length 100 mm	57	57-62	100	3.937
ESA3320N100-62	Die set n. 62 - length 100 mm	62	62-66	110	4.331
ESA3320N100-66	Die set n. 66 - length 100 mm	66	66-70	100	3.937
ESA3320N100-70	Die set n. 70 - length 100 mm	70	70-72	100	3.937
ESA3330NL100D072L2	Die set n. 72 - length 100 mm	72	72-73	100	3.937
ESA3320N240KT	Kit 12 dies MB240/MV240 (n.15 to n.66)	-	-	-	-
ESA3320N240KTF	Kit 18 dies MB240/MV240 (n.15 to n.72)	-	-	-	-

#### Notes:

*Refrigeration hose special dies available upon request*

# CRIMPING MACHINES

## MV 350

FIELD SERVICE & MOBILE / CONTAINER WORKSHOP

MOBILE VAN



### KEY ADVANTAGES

- Robust design
- Large opening
- High crimping force
- Ergonomic micrometer
- High crimping speed
- Radial movement of the dies
- Cylinder protection
- Remote head mounting option possible

### MAIN APPLICATIONS

Designed for hydraulic maintenance specialists for on-site repairs in mobile vans and an ideal solution for container shops. The high crimp force makes this machine a versatile solution for the whole hydraulic hose range. It is possible to install the crimp head separately from the power pack to gain space inside the vehicle and obtain a lower centre of gravity.

### TECHNICAL SPECIFICATIONS

<b>Dimensions:</b>	650 x 550 x 750 mm (26 x 22 x 30")	<b>Motor:</b>	2.0 kW
<b>Net Weight:</b>	210 kg (463 lb)	<b>Noise Level:</b>	<65 dB A
<b>Packaging:</b>	800 x 600 x 830 mm (31 x 24 x 33")	<b>Crimp Range:</b>	4 - 130 mm (0.157 - 5.118")
<b>Gross Weight:</b>	260 kg (573 lb)	<b>Crimp Force:</b>	350 t
<b>Voltages:</b>	12 V	<b>Opening with Dies:</b>	+54 mm (+2.125")
	24 V	<b>Complete Opening:</b>	180 mm (7.086")
	220/240 V, 3Ph, 50 Hz	<b>Master Die Length:</b>	115 mm (4.528")
	380/415 V, 3Ph, 50 Hz	<b>Standard Dies:</b>	15, 18, 21, 24, 27, 30, 33, 36, 39, 42,
	208/240 V, 3Ph, 60 Hz		45, 48, 51, 57, 62, 66, 70, 72, 73, 76
	380/415 V, 3Ph, 60 Hz	<b>Technical Features:</b>	
<b>Capacity:</b>	2wb: 3" max.		Options available: Die storage, ergonomic gun, battery and charger, die sets for brake and air-conditioning hoses, marking dies
	4ws: 2" max.		<b>Safety Remarks:</b>
	6ws: 2" max.		Possible limitations in case of double elbow fittings
	Textile / Suction Hose: 4"		

### HOSE AND FITTING SELECTION

Hose Type	Fittings Type	Max. Hose Size	Ref. Hoses
2 Wire Braid & Textile	MF2000 Multifit; MF3000 OPK; MF3000 OPF	3" with extra dies	Tractor; Harvester; Lyteflex; Pilot; Cover; Equator; Rockmaster (braided); Shieldmaster (braided); Astro; Multitex; Hydroplast; Spirtex/K
4 Wire Spirals	MF2000 Multifit; MF2000 Interlock Plus; MF2000 Spiralfit; MF3000 OPK; MF3000 OPF	2"	Rockmaster (spiral); Shieldmaster (spiral); GoldenISO Xtraflex; Goldenblast
6 Wire Spirals	MF2000 Interlock Plus; MF2000 Spiralfit	2"	Rockmaster/13; GoldenISO/35 Xtraflex; Goldenblast/six
6 Wire Spirals	MF2000 Interlock Plus; MF2000 Spiralfit; MF2000 Xtralock	1½"	Diamondspir; Rockmaster/15; GoldenISO/42 Xtraflex; Shieldmaster/6000

# CRIMPING MACHINES

## MV 350

FIELD SERVICE & MOBILE / CONTAINER WORKSHOP

MOBILE VAN

### ORDERING INFORMATION

Product Code	Description
EOA3351N12350	MV 350 12V 12V
EOA3352N24350	MV 350 24V 24V
EOA3324NMV350	MV 350 380/415V 3PH 50HZ
EOA3327NMV350	MV 350 220/240V 3PH 50HZ
EOA3329NMV350	MV 350 208/240V 3PH 60HZ
EOA332BNMV350	MV 350 380/415V 3PH 60HZ

### AVAILABLE DIE SETS

Product Code	Description	N°	Crimp Range	Die Length (mm)	Die Length (inch)
ESA3220NL56-10	Die set n. 10 - length 56 mm	10	10-12	56	2.205
ESA3220NL56-12	Die set n. 12 - length 56 mm	12	12-15	56	2.205
ESA3220NL56-15	Die set n. 15 - length 56 mm	15	15-18	56	2.205
ESA3220NL56-18	Die set n. 18 - length 56 mm	18	18-21	56	2.205
ESA3220NL56-21	Die set n. 21 - length 56 mm	21	21-24	56	2.205
ESA3320N140-24	Die set n. 24 - length 70 mm	24	24-27	70	2.756
ESA3320NL90-27	Die set n. 27 - length 90 mm	27	27-30	90	3.543
ESA3320NL90-30	Die set n. 30 - length 90 mm	30	30-33	90	3.543
ESA3320NL90-33	Die set n. 33 - length 90 mm	33	33-36	90	3.543
ESA3320NL90-36	Die set n. 36 - length 90 mm	36	36-39	90	3.543
ESA3320NL90-39	Die set n. 39 - length 90 mm	39	39-42	90	3.543
ESA3320NL90-42	Die set n. 42 - length 90 mm	42	42-45	90	3.543
ESA3320N100-45	Die set n. 45 - length 100 mm	45	45-48	100	3.937
ESA3320NL100-48	Die set n. 48 - length 100 mm	48	48-51	100	3.937
ESA3320N110-51	Die set n. 51 - length 110 mm	51	51-57	110	4.331
ESA3320N110-57	Die set n. 57 - length 110 mm	57	57-62	110	4.331
ESA3320N110-62	Die set n. 62 - length 110 mm	62	62-66	110	4.331
ESA3330N125-66	Die set n. 66 - length 110 mm	66	66-70	110	4.331
ESA3320N100-70	Die set n. 70 - length 100 mm	70	70-72	100	3.937
ESA3330NL100D072L2	Die set n. 72 - length 100 mm	72	72-73	100	3.937
ESA3540N125-73	Die set n. 73 - length 125 mm	73	73-76	125	4.921
ESA3540N125-76A	Die set n. 76 - length 125 mm	76	76-86	125	4.921
ESA3540N125-90	Die set n. 90 - length 125 mm	90	90-95	125	4.921
ESA3540N12595	Die set n. 95 - length 125 mm	95	95-105	125	4.921
ESA3330N340KT	Kit 13 dies MB350/L/MV350 (n.15 to n.73)	-	-	-	-
ESA3330N340KTF	Kit 20 dies MB350/L/MV350 (n.15 to n.76)	-	-	-	-

#### Notes:

*Refrigeration hose special dies available upon request*

# CRIMPING MACHINES

## GOLDENCRIMP 450

ASSEMBLING FOR FIELD REPAIR

**BENCHTOP CRIMP MACHINE**



### KEY ADVANTAGES

- High crimp force (450 tons)
- Large opening
- Wide family of dies for industrial hoses
- Long master dies
- Robust - designed for harsh environments
- Low noise level
- Easy die set-up with ergonomic gun
- Metallic guard for the set stop

### MAIN APPLICATIONS

**Dedicated to field repair assemblers operating in harsh environments (mines, construction areas, drilling rigs, etc.). Suitable for the whole hose range (small and large bore hoses). Designed to be extremely robust to resist aggressive environmental conditions (wiper seal, powder protection, grease connections for master dies, easy accessibility for maintenance and handling).**

### TECHNICAL SPECIFICATIONS

<b>Dimensions:</b>	830 x 775 x 1450 mm (33 x 31 x 57")	<b>Noise Level:</b>	<65 dB A
<b>Net Weight:</b>	720 kg (1587 lb)	<b>Crimp Range:</b>	4 - 130 mm (0.157 - 5.118")
<b>Packaging:</b>	1120 x 1020 x 1770 mm (44 x 40 x 70")	<b>Crimp Force:</b>	450 t
<b>Voltages:</b>	220/240 V, 3Ph, 50 Hz	<b>Opening with Dies:</b>	+70 mm (+2.755")
	380/415 V, 3Ph, 50 Hz	<b>Complete Opening:</b>	202 mm (7.950")
	208/240 V, 3Ph, 60 Hz	<b>Master Die Length:</b>	140 mm (5.512")
	380/415 V, 3Ph, 60 Hz	<b>Standard Dies:</b>	15, 18, 21, 24, 27, 30, 33, 36, 39, 42, 45, 48, 51, 57, 62, 66, 70, 72, 73, 76
<b>Capacity:</b>	6ws: 3" max.	<b>Safety remarks:</b>	Please consider hose-fitting-machine integration when crimping
	Industrial: 4" max.		
	6ws: 3" max.		
<b>Motor:</b>	5.5 kW		

### HOSE AND FITTING SELECTION

Hose Type	Fittings Type	Max. Hose Size	Ref. Hoses
2 Wire Braid & Textile	MF2000 Multifit; MF3000 OPF; MF3000 OPK	4"	Tractor; Harvester; Lyteflex; Pilot; Cover; Equator; Rockmaster (braided); Shieldmaster (braided); Astro; Multitex; Hydroplast; Spirtex/K
4 Wire Spirals	MF2000 Multifit; MF2000 Interlock Plus; MF2000 Xtralock; MF2000 Spiralfit; MF3000 OPF; MF3000 OPK	3"	Rockmaster (spiral); Shieldmaster (spiral); GoldenISO Xtraflex; Xtraflow/4WS; Goldenblast
6 Wire Spirals	MF2000 Interlock Plus; MF2000 Xtralock; MF2000 Spiralfit	3"	Diamondspir/21; Rockmaster/13; Rockmaster/15; Goldenblast/Six
Industrial Textile Hoses		4"	Spirtex/K; Others



Performances measured on a 400 V, 3Ph, 50 Hz network

# CRIMPING MACHINES

## GOLDENCRIMP 450

**ASSEMBLING FOR FIELD REPAIR**

**BENCHTOP CRIMP MACHINE**

### ORDERING INFORMATION

Product Code	Description
EOA3324NMSCRIG450	GOLDENCRIMP/450 380/415V 3PH 50HZ

### AVAILABLE DIE SETS

Product Code	Description	N°	Crimp Range	Die Length (mm)	Die Length (inch)
ESA3220NL56-10	Die set n. 10 - length 56 mm	10	10-12	56	2.205
ESA3220NL56-12	Die set n. 12 - length 56 mm	12	12-15	56	2.205
ESA3220NL56-15	Die set n. 15 - length 56 mm	15	15-18	56	2.205
ESA3220NL56-18	Die set n. 18 - length 56 mm	18	18-21	56	2.205
ESA3220NL56-21	Die set n. 21 - length 56 mm	21	21-24	56	2.205
ESA3320N140-24	Die set n. 24 - length 70 mm	24	24-27	70	2.756
ESA3320NL90-27	Die set n. 27 - length 90 mm	27	27-30	90	3.543
ESA3320NL90-30	Die set n. 30 - length 90 mm	30	30-33	90	3.543
ESA3320NL90-33	Die set n. 33 - length 90 mm	33	33-36	90	3.543
ESA3320NL90-36	Die set n. 36 - length 90 mm	36	36-39	90	3.543
ESA3320NL90-39	Die set n. 39 - length 90 mm	39	39-42	90	3.543
ESA3320NL90-42	Die set n. 42 - length 90 mm	42	42-45	90	3.543
ESA3320N100-45	Die set n. 45 - length 100 mm	45	45-48	100	3.937
ESA3320NL100-48	Die set n. 48 - length 100 mm	48	48-51	100	3.937
ESA3320N110-51	Die set n. 51 - length 110 mm	51	51-57	110	4.331
ESA3320N110-57	Die set n. 57 - length 110 mm	57	57-62	110	4.331
ESA3320N110-62	Die set n. 62 - length 110 mm	62	62-66	110	4.331
ESA3330N125-66	Die set n. 66 - length 110 mm	66	66-70	110	4.331
ESA3320N100-70	Die set n. 70 - length 100 mm	70	70-72	100	3.937
ESA3330NL100D072L2	Die set n. 72 - length 100 mm	72	72-73	100	3.937
ESA3330NL125D073L4	Die set n. 73 - length 125-28 mm, Reinforced pin	73	73-76	125	4.921
ESA3540N125-76	Die set n. 76 - length 125 mm	76	76-86	125	4.921
ESA3540NL150D086L6	Die set n. 86 - length 150 mm	86	86-90	150	5.906
ESA3540N125-90F	Die set n. 90 - length 125 mm	90	90-95	125	4.921
ESA3440NL150D095L6	Die set n. 95 - length 150 mm	95	95-105	150	5.906
ESA3550NL150D105L	Die set n. 105 - length 150 mm	105	105-112	150	5.906
ESA3550NL150D112L	Die set n. 112 - length 150 mm	112	112-122	150	5.906
ESA3440NL130D122L5	Die set n. 122 - length 130 mm REINF PIN	122	122-130	130	5.118
ESA3330N450KT	Kit 13 die set GC 450 (15 to 73)	-	-	-	-
ESA3330N450KTF	Kit 20 die set GC4 50 (15 to 76)	-	-	-	-

# CRIMPING MACHINES

## MVB 140

### MAINTENANCE WORKSHOP

### VERTICAL BENCHTOP, CAGE DIES



#### KEY ADVANTAGES

- Easy use and maintenance
- Easy intuitive adjustment of crimp diameter
- Micrometer set-up with automatic stop
- Retractable pusher for easy insertion of the dies
- 'Plug & play' system (power pack already integrated)
- Wide clearance for tooling installation and fitting positioning
- Easy positioning of the spacer plates

#### MAIN APPLICATIONS

Dedicated to hydraulic maintenance shops and on-site repairs (construction machines, public works equipment, handling and lifting equipment, agriculture machines, etc.). Designed to crimp small size hoses up to 1 1/4" 4 wire spiral hose (with the exception of double skive type fittings). It can be used for small series productions due to its precise crimp operations and high durability.

#### TECHNICAL SPECIFICATIONS

<b>Dimensions:</b>	690 x 280 x 550 mm (48 x 19.5 x 38.5")	<b>Motor:</b>	0.8 kW
<b>Net Weight:</b>	86 kg (190 lb)	<b>Noise Level:</b>	<86 dB A
<b>Gross Weight:</b>	110 kg (243 lb)	<b>Crimp Range:</b>	11.5 to 55 mm (0.453 - 2.165")
<b>Voltages:</b>	110 V, 1Ph, 60 Hz	<b>Crimp Force:</b>	140 t
<b>Capacity:</b>	2wb: 1 1/4" max. 4ws: 1 1/4" max.	<b>Standard Dies:</b>	20, 30, 40, 50, 80, S1

#### Technical Features:

- Spacer plates supplied as standard: size 0 (positive crimping set by dedicated spacers)
- Professional approach with set stop and remote control drive allows easy crimping both in the field and in-shop assembling
- Possible limitations if used with double-elbow fittings
- Not suitable for hoses with double skive fittings (Interlock Plus, Xtralock)

#### HOSE AND FITTING SELECTION

Hose Type	Fittings Type	Max. Hose Size	Ref. Hoses
2 Wire Braid & Textile	MF2000 Multifit; MF3000 OPK; MF3000 OPF	1 1/4	Tractor; Harvester; Lyteflex; Pilot; Cover; Equator; Rockmaster (braided); Shieldmaster (braided); Astro; Multitex; Hydroplast; Spirtex/K
4 Wire Spirals	MF2000 Multifit; MF3000 OPK; MF3000 OPF	1 1/4	Rockmaster (spiral); Shieldmaster (spiral); GoldenISO Xtraflex

# CRIMPING MACHINES

## MVB 140

### MAINTENANCE WORKSHOP

### VERTICAL BENCHTOP, CAGE DIES

### ORDERING INFORMATION

Product Code	Description
EOA3225NMVB140	MVB 140 110V 1PH 60HZ
EOA3225SMVB140	MVB 140 110V 60Hz (STD. DIES INCLUDED)
EOA3225SMVB140S1	MVB 140 110V 60Hz (w 30,40,50,80,S1 DIES)

### AVAILABLE DIE SETS

Product Code	Description	N°	Crimp Range	Die Length (mm)	Die Length (inch)
ESA3210NSUD-10	DIES SET USA market 10	-	11,5-13,9	45	1.772
ESA3210NSUD-20	DIES SET USA market 20	-	14,0-15,9	45	1.772
ESA3210NSUD-30	DIES SET USA market 30	-	16,0-18,9	45	1.772
ESA3210NSUD-40	DIES SET USA market 40	-	19,0-21,9	45	1.772
ESA3210NSUD-50	DIES SET USA market 50	-	22,0-23,9	45	1.772
ESA3210NSUD-60	DIES SET USA market 60	-	24,0-26,9	57	2.244
ESA3210NSUD-70	DIES SET USA market 70	-	27,0-29,9	57	2.244
ESA3210NSUD-80	DIES SET USA market 80	-	30,0-33,9	57	2.244
ESA3210NSUD-90	DIES SET USA market 90	-	34,0-36,9	57	2.244
ESA3210NSUD-S1	DIES SET USA market S1	-	37,0-40,9	70	2.756
ESA3210NSUD-S2	DIES SET USA market S2	-	41,0-45,9	70	2.756
ESA3210NSUD-S3	DIES SET USA market S3	-	46,0-48,9	70	2.756
ESA3210NSUD-S4	DIES SET USA market S4	-	49,0-55,0	70	2.756
ESA3320NTKIT5JB	DIE SET 5J MVB140	-	-	-	-
ESA3330NTKIT3J	KIT 3 DIE SETS 5/8-3/4 MVB140	-	-	-	-
ESA3330NTKIT5JOPT	KIT 5 DIE SETS OPTION MVB140	-	-	-	-

### Notes:

*Crimp head weight: 46 kg (101 lb)*

*Retraction of the cylinder and consequent crimp stroke start position is governed by the remote control crimp switch, to enable quicker crimping and increased productivity*



# CRIMPING MACHINES



## MS 140

**ASSEMBLING FOR MASS PRODUCTION  
STAND TYPE CRIMP MACHINE, SCS CONTROL**

### KEY ADVANTAGES

- The quickest machine of the MS machine series
- Safe Crimp System (SCS) control
- Large production capacity (small/medium bore)
- Low noise level
- Precise
- Robust
- Easy die set-up with ergonomic gun

### MAIN APPLICATIONS

**Dedicated to professional assemblers for mass production of small/medium bore hoses, OEM assembly shops and large maintenance activities. Ideal when high production speeds are required.**

### TECHNICAL SPECIFICATIONS

<b>Dimensions:</b>	890 x 810 x 1390 mm (35 x 32 x 55")	<b>Motor:</b>	5.5 kW
<b>Net Weight:</b>	675 kg (1488 lb)	<b>Noise Level:</b>	<69 dB A
<b>Packaging:</b>	1120 x 1020 x 1770 mm (44 x 40 x 70")	<b>Crimp Range:</b>	4 - 70 mm (0.157 - 2.756")
<b>Voltages:</b>	220/240 V, 3Ph, 50 Hz	<b>Crimp Force:</b>	140 t
	380/415 V, 3Ph, 50 Hz	<b>Opening with Dies:</b>	+45 mm (+1.772")
	208/240 V, 3Ph, 60 Hz	<b>Complete Opening:</b>	125 mm (4.921")
<b>Capacity:</b>	2wb: 1 1/4" max.	<b>Master Die Length:</b>	80 mm (3.150")
	4ws: 1 1/4" max.	<b>Standard Dies:</b>	15, 18, 21, 24, 27, 30, 33, 36, 39, 42, 45, 48
		<b>Technical Features:</b>	Options available: Die sets for brake and air-conditioning hoses, marking dies

### HOSE AND FITTING SELECTION

Hose Type	Fittings Type	Max. Hose Size	Ref. Hoses
2 Wire Braid & Textile	MF2000 Multifit; MF3000 OPK; MF3000 OPF	1 1/4"	Tractor; Harvester; Lyteflex; Pilot; Cover; Equator; Rockmaster (braided); Shieldmaster (braided); Astro; Multitex; Hydroplast; Spirtex/K
4 Wire Spirals	MF2000 Multifit; MF3000 OPK	1 1/4"	Rockmaster (spiral); Shieldmaster (spiral); GoldenISO Xtraflex
4 Wire Spirals	MF2000 Interlock Plus; MF2000 Xtralock; MF2000 Spiralfit	1"	Rockmaster (spiral); Shieldmaster (spiral); GoldenISO Xtraflex; GoldenBlast



Performances measured on a 400 V, 3Ph, 50 Hz network

# CRIMPING MACHINES

## MS 140

**ASSEMBLING FOR MASS PRODUCTION**

**STAND TYPE CRIMP MACHINE, SCS CONTROL**

### ORDERING INFORMATION

Product Code	Description
EOA3434NSC140	MS 140 SCS 380/415V 3PH 50HZ
EOA3437NSC140	MS 140 SCS 220/240V 3PH 50HZ
EOA3439NSC140	MS 140 SCS 208/240V 3PH 60HZ

### AVAILABLE DIE SETS

Product Code	Description	N°	Crimp Range	Die Length (mm)	Die Length (inch)
ESA3220NL56-10	Die set n. 10 - length 56 mm	10	10-12	56	2.205
ESA3320N140-12	Die set n. 12 - length 70 mm	12	12-15	70	2.756
ESA3320N140-15	Die set n. 15 - length 70 mm	15	15-18	70	2.756
ESA3320N140-18	Die set n. 18 - length 70 mm	18	18-21	70	2.756
ESA3320N140-21	Die set n. 21 - length 70 mm	21	21-24	70	2.756
ESA3320N140-24	Die set n. 24 - length 70 mm	24	24-27	70	2.756
ESA3320N140-27	Die set n. 27 - length 70 mm	27	27-30	70	2.756
ESA3320N140-30	Die set n. 30 - length 70 mm	30	30-33	70	2.756
ESA3220N137-33	Die set n. 33 - length 70 mm	33	33-36	70	2.756
ESA3220N75-36	Die set n. 36 - length 75 mm	36	36-39	75	2.953
ESA3220N137-39	Die set n. 39 - length 70 mm	39	39-42	70	2.756
ESA3320N140-42	Die set n. 42 - length 70 mm	42	42-45	70	2.756
ESA3220N137-45	Die set n. 45 - length 70 mm	45	45-48	70	2.756
ESA3220N137-48	Die set n. 48 - length 70 mm	48	48-51	70	2.756
ESA3220N137-51	Die set n. 51 - length 75 mm	51	51-57	75	2.953
ESA3540N140KT	Kit 10 dies MS140 (n.15 to n.48)				
ESA3540N140KTF	Kit 12 dies MS140 (n.15 to n.48)				

#### Notes:

*Refrigeration hose special dies available upon request*

# CRIMPING MACHINES

## MS 280 L

**ASSEMBLING FOR MASS PRODUCTION  
STAND TYPE CRIMP MACHINE, SCS CONTROL**



### KEY ADVANTAGES

- Robust structure for tough working environments
- First OEM machine up to 1 1/4"
- Safe Crimp System (SCS) integrated function
- Separate power pack
- Low noise
- Fast and ergonomic
- Low maintenance
- Easy die set-up with ergonomic gun

### MAIN APPLICATIONS

**Dedicated to professional maintenance shops and small OEM workshops. Versatile crimp machine for the whole hose range up to 2" size 4 wire spiral included. The optimum choice for professional assemblers that require high precision and quality control with SCS (Safe Crimp System) for small/medium OEM activities.**

### TECHNICAL SPECIFICATIONS

<b>Net Weight:</b>	450 kg (992 lb)	<b>Motor:</b>	5.5 kW
<b>Packaging:</b>	850 x 850 x 1300 mm (34 x 34 x 51")	<b>Noise Level:</b>	<65 dB A
<b>Gross Weight:</b>	500 kg (1102 lb)	<b>Crimp Range:</b>	4 - 130 mm (0.157 - 5.118")
<b>Voltages:</b>	220/240 V, 3Ph, 50 Hz	<b>Crimp Force:</b>	280 t
	380/415 V, 3Ph, 50 Hz	<b>Opening with Dies:</b>	+54 mm (+2.126")
	208/240 V, 3Ph, 60 Hz	<b>Complete Opening:</b>	180 mm (7.087")
	380/415 V, 3Ph, 60 Hz	<b>Master Die Length:</b>	115 mm (4.528")
<b>Capacity:</b>	2wb: 3" max.	<b>Standard Dies:</b>	15, 18, 21, 24, 27, 30, 33, 36, 39, 42, 45, 48, 51, 57, 62, 66, 70, 72
	4ws: 2" max.	<b>Technical Features:</b>	Net weight includes the separate power pack: 180 kg (396 lb); dimensions 1000 x 700 x 870 mm (39 x 27.5 x 34")

### Safety Remarks:

Please consider hose-fitting-machine integration when crimping

### HOSE AND FITTING SELECTION

Hose Type	Fittings Type	Max. Hose Size	Ref. Hoses
2 Wire Braid & Textile	MF2000 Multifit	2"	Tractor; Lyteflex; Pilot; Cover; Equator; Rockmaster (braided); Shieldmaster (braided); Astro; Multitex; Hydroplast; Spirtex/K
4 Wire Spirals	MF2000 Multifit; MF2000 Interlock Plus; MF2000 Xtralock; MF2000 Spiralfit	2"	Rockmaster (spiral); Shieldmaster (spiral); GoldenISO Xtraflex; Goldenblast
Industrial Textile Hoses	Various	2"	Spirtex/K; Others



Performances measured on a 400 V, 3Ph, 50 Hz network

# CRIMPING MACHINES

## MS 280 L

**ASSEMBLING FOR MASS PRODUCTION**

**STAND TYPE CRIMP MACHINE, SCS CONTROL**

### ORDERING INFORMATION

Product Code	Description
EOA3434NMS280L	MS 280 L 380/415V 3PH 50HZ
EOA3437NMS280L	MS 280 L 220/240V 3PH 50HZ
EOA3439NMS280L	MS 280 L 208/240V 3PH 60HZ
EOA343BNMS280L	MS 280 L 380/415V 3PH 60HZ

### AVAILABLE DIE SETS

Product Code	Description	N°	Crimp Range	Die Length (mm)	Die Length (inch)
ESA3220NL56-10	Die set n. 10 - length 56 mm	10	10-12	56	2.205
ESA3220NL56-12	Die set n. 12 - length 56 mm	12	12-15	56	2.205
ESA3220NL56-15	Die set n. 15 - length 56 mm	15	15-18	56	2.205
ESA3220NL56-18	Die set n. 18 - length 56 mm	18	18-21	56	2.205
ESA3220NL56-21	Die set n. 21 - length 56 mm	21	21-24	56	2.205
ESA3320N140-24	Die set n. 24 - length 70 mm	24	24-27	70	2.756
ESA3320NL90-27	Die set n. 27 - length 90 mm	27	27-30	90	3.543
ESA3320NL90-30	Die set n. 30 - length 90 mm	30	30-33	90	3.543
ESA3320NL90-33	Die set n. 33 - length 90 mm	33	33-36	90	3.543
ESA3320NL90-36	Die set n. 36 - length 90 mm	36	36-39	90	3.543
ESA3320NL90-39	Die set n. 39 - length 90 mm	39	39-42	90	3.543
ESA3320NL90-42	Die set n. 42 - length 90 mm	42	42-45	90	3.543
ESA3320N100-45	Die set n. 45 - length 100 mm	45	45-48	100	3.937
ESA3320NL100-48	Die set n. 48 - length 100 mm	48	48-51	100	3.937
ESA3320N100-51	Die set n. 51 - length 100 mm	51	51-57	100	3.937
ESA3320N100-57	Die set n. 57 - length 100 mm	57	57-62	110	3.937
ESA3320N110-62	Die set n. 62 - length 110 mm	62	62-66	110	4.331
ESA3330N100-66	Die set n. 66 - length 100 mm	66	66-70	100	3.937
ESA3320N100-70	Die set n. 70 - length 100 mm	70	70-72	100	3.937
ESA3330NL100D072L2	Die set n. 72 - length 100 mm	72	72-73	100	3.937
ESA3320N240KTF	Kit 18 dies MB240/MV240 (n.15 to n.72)	-	-	-	-

# CRIMPING MACHINES

## MS 320

**ASSEMBLING FOR MASS PRODUCTION  
STAND TYPE CRIMP MACHINE, SCS CONTROL**



### KEY ADVANTAGES

- High crimp force
- Large opening
- Safe Crimp System (SCS) control
- Wide family of dies for industrial hoses
- Robust structure
- Fast and ergonomic
- Low noise level
- Easy die-set up with ergonomic gun

### MAIN APPLICATIONS

**Dedicated to professional assemblers for mass production, OEM assembly shops and large maintenance activities.**

### TECHNICAL SPECIFICATIONS

<b>Dimensions:</b>	1240 x 995 x 1615 mm (49 x 39 x 64")	<b>Motor:</b>	5.5 kW
<b>Net Weight:</b>	1900 kg (4189 lb)	<b>Noise Level:</b>	<65 dB A
<b>Packaging:</b>	1400 x 1100 x 1960 mm (55 x 43 x 77")	<b>Crimp Range:</b>	4 - 130 mm (0.157 - 5.118")
<b>Gross Weight:</b>	2230 kg (4916 lb)	<b>Crimp Force:</b>	320 t
<b>Voltages:</b>	220/240 V, 3Ph, 50 Hz	<b>Opening with Dies:</b>	+80 mm (+3.149")
	380/415 V, 3Ph, 50 Hz	<b>Complete Opening:</b>	207 mm (8.149")
	208/240 V, 3Ph, 60 Hz	<b>Master Die Length:</b>	100 mm (3.937")
	380/415 V, 3Ph, 60 Hz	<b>Standard Dies:</b>	15, 18, 21, 24, 27, 30, 33, 36, 39, 42, 45, 48, 51, 57, 62, 66, 70, 72, 73, 76
<b>Capacity:</b>	2wb: 3" max.	<b>Technical Features:</b>	Options available: Die sets for brake and air-conditioning hoses, marking dies
	4ws: 2" max.	<b>Safety Features:</b>	Please consider hose-fitting-machine integration when crimping
	6ws: 2" max.		
	Textile & Suction Hose: 4" max.		

### HOSE AND FITTING SELECTION

Hose Type	Fittings Type	Max. Hose Size	Ref. Hoses
2 Wire Braid & Textile	MF2000 Multifit	3" with extra dies	Tractor; Harvester; Lyteflex; Pilot; Cover; Equator; Rockmaster (braided); Shieldmaster (braided); Astro; Multitex; Hydroplast; Spirtex/K
4 Wire Spirals	MF2000 Multifit; MF2000 Interlock Plus; MF2000 Xtralock	2"	Rockmaster (spiral); Shieldmaster (spiral); GoldenISO Xtraflex; Goldenblast/six
6 Wire Spirals	MF2000 Interlock Plus	2"	Rockmaster/13
6 Wire Spirals	MF2000 Spiralfit; MF2000 Xtralock	2"	Shieldmaster/6000; Diamondspir; Goldenblast/six; GoldenISO Xtraflex



Performances measured on a 400 V, 3Ph, 50 Hz network

# CRIMPING MACHINES

## MS 320

**ASSEMBLING FOR MASS PRODUCTION**

**STAND TYPE CRIMP MACHINE, SCS CONTROL**

### ORDERING INFORMATION

Product Code	Description
EOA3434NSC320	MS 320 SCS 380/415V 3PH 50HZ
EOA3437NSC320	MS 320 SCS 220/240V 3PH 50HZ
EOA3439NSC320	MS 320 SCS 208/240V 3PH 60HZ
EOA343BNSC320	MS 320 SCS 380/415V 3PH 60HZ

### AVAILABLE DIE SETS

Product Code	Description	N°	Crimp Range	Die Length (mm)	Die Length (inch)
ESA3430NL90-10	Die set n. 10 - length 90 mm	10	10-12	90	3.543
ESA3430NL90-12	Die set n. 12 - length 90 mm	12	12-15	90	3.543
ESA3430NL90-15	Die set n. 15 - length 90 mm	15	15-18	90	3.543
ESA3430NL90-18	Die set n. 18 - length 90 mm	18	18-21	90	3.543
ESA3430NL90-21	Die set n. 21 - length 90 mm	21	21-24	90	3.543
ESA3320NL90-24	Die set n. 24 - length 90 mm	24	24-27	90	3.543
ESA3320NL90-27	Die set n. 27 - length 90 mm	27	27-30	90	3.543
ESA3320NL90-30	Die set n. 30 - length 90 mm	30	30-33	90	3.543
ESA3320NL90-33	Die set n. 33 - length 90 mm	33	33-36	90	3.543
ESA3320NL90-36	Die set n. 36 - length 90 mm	36	36-39	90	3.543
ESA3320NL90-39	Die set n. 39 - length 90 mm	39	39-42	90	3.543
ESA3320NL90-42	Die set n. 42 - length 90 mm	42	42-45	90	3.543
ESA3430N100-45	Die set n. 45 - length 95 mm	45	45-48	95	3.740
ESA3320NL100-48	Die set n. 48 - length 100 mm	48	48-51	100	3.937
ESA3430N110-51	Die set n. 51 - length 110 mm	51	51-57	110	4.331
ESA3430N110-57	Die set n. 57 - length 110 mm	57	57-62	110	4.331
ESA3320N110-62	Die set n. 62 - length 110 mm	62	62-66	110	4.331
ESA3430N110-66	Die set n. 66 - length 110 mm	66	66-70	110	4.331
ESA3320N100-70	Die set n. 70 - length 100 mm	70	70-72	100	3.937
ESA3330NL100D072L2	Die set n. 72 - length 100 mm	72	72-73	100	3.937
ESA3340NL120D073L8	Die set n. 73 - length 120 mm	73	73-76	120	4.724
ESA3340NL120D076L8	Die set n. 76 - length 120 mm	76	76-86	120	4.724
ESA3340NL100D086L6	Die set n. 86 - length 100-65 mm	86	86-90	100	3.937
ESA3430NL100D090L6	Die set n. 90 - length 100 mm, Reinforced Pin	90	90-95	100	3.937
ESA3430NL100D095L6	Die set n. 95 - length 100 mm, Reinforced Pin	95	95-105	100	3.937
ESA3540N320KT	Kit 13 dies MS320 (n.15 to n.73)				
ESA3540N320KTF	Kit 20 dies MS320 (n.15 to n.76)				

# CRIMPING MACHINES

## MS 480

**ASSEMBLING FOR MASS PRODUCTION  
STAND TYPE CRIMP MACHINE, SCS CONTROL**



### KEY ADVANTAGES

- High crimp force
- Large opening
- Safe Crimp System (SCS) control
- Wide family of dies for industrial hoses
- Long master dies
- Robust
- Low noise level
- Easy die set-up with ergonomic gun

### MAIN APPLICATIONS

**Dedicated to professional assemblers, large OEM suppliers and special applications. This machine is particularly suited to medium and large bore hose assembly operations.**

### TECHNICAL SPECIFICATIONS

<b>Dimensions:</b>	1300 x 900 x 1700 mm (51 x 35 x 67")	<b>Motor:</b>	5.5 kW
<b>Net Weight:</b>	2200 kg (4850 lb)	<b>Noise Level:</b>	<65 dB A
<b>Packaging:</b>	1400 x 1100 x 1960 mm (55 x 43 x 77")	<b>Crimp Range:</b>	4 - 160 mm (0.157 - 6.299")
<b>Gross Weight:</b>	2230 kg (4916 lb)	<b>Crimp Force:</b>	480 t
<b>Voltages:</b>	220/240 V, 3Ph, 50 Hz	<b>Opening with Dies:</b>	+85 mm (+3.346")
	380/415 V, 3Ph, 50 Hz	<b>Complete Opening:</b>	212 mm (8.346")
	208/240 V, 3Ph, 60 Hz	<b>Master Die Length:</b>	125 mm (4.921")
	380/415 V, 3Ph, 60 Hz	<b>Standard Dies:</b>	15, 18, 21, 24, 27, 30, 33, 36, 39, 42, 45, 48, 51, 57, 62, 66, 70, 72, 73, 76
<b>Capacity:</b>	6ws: 3" max.	<b>Technical Features:</b>	Options available: Die sets for brake and air-conditioning hoses, marking dies
	8ws: 3" max.	<b>Safety Remarks:</b>	Please consider hose-fitting-machine integration when crimping
	Industrial Textile Hoses: 4" max.		

### HOSE AND FITTING SELECTION

Hose Type	Fittings Type	Max. Hose Size	Ref. Hoses
2 Wire Braid & Textile	MF2000 Multifit	3½"	Harvester; Lyteflex; Pilot; Cover; Equator; Rockmaster (braided); Shieldmaster (braided); Astro; Multitex; Hydroplast; Spirtex/K
4 Wire Spirals	MF2000 Multifit; MF2000 Interlock Plus; MF2000 Xtralock; MF2000 Spiralfit	4"	Rockmaster (spiral); Shieldmaster (spiral); GoldenISO Xtraflex; Xtraflow/4WS; Goldenblast
6 Wire Spirals	MF2000 Interlock Plus; MF2000 Xtralock; MF2000 Spiralfit	3"	Diamondspir/21; Rockmaster/13; Rockmaster/15; Goldenblast/six
Industrial Textile Hoses		4"	Spirtex/K; Others



Performances measured on a 400 V, 3Ph, 50 Hz network

# CRIMPING MACHINES

## MS 480

**ASSEMBLING FOR MASS PRODUCTION**

**STAND TYPE CRIMP MACHINE, SCS CONTROL**

### ORDERING INFORMATION

Product Code	Description
EOA3544NSC480	MS 480 SCS 380/415V 3Ph 50 Hz
EOA3547NSC480	MS 480 SCS 220/240V 3Ph 50 Hz
EOA3549NSC480	MS 480 SCS 208/240V 3Ph 60 Hz
EOA354BNSC480	MS 480 SCS 380/415V 3Ph 60 Hz

### AVAILABLE DIE SETS

Product Code	Description	N°	Crimp Range	Die Length (mm)	Die Length (inch)
ESA3430NL90-10	Die set n. 10 - length 90 mm	10	10-12	90	3.543
ESA3430NL90-12	Die set n. 12 - length 90 mm	12	12-15	90	3.543
ESA3430NL90-15	Die set n. 15 - length 90 mm	15	15-18	90	3.543
ESA3430NL90-18	Die set n. 18 - length 90 mm	18	18-21	90	3.543
ESA3430NL90-21	Die set n. 21 - length 90 mm	21	21-24	90	3.543
ESA3320NL90-24	Die set n. 24 - length 90 mm	24	24-27	90	3.543
ESA3320NL90-27	Die set n. 27 - length 90 mm	27	27-30	90	3.543
ESA3430NL100D30L2	Die set n. 30 - length 100 mm	30	30-33	100	3.937
ESA3320NL90-33	Die set n. 33 - length 90 mm	33	33-36	90	3.543
ESA3320NL90-36	Die set n. 36 - length 90 mm	36	36-39	90	3.543
ESA3320NL90-39	Die set n. 39 - length 90 mm	39	39-42	90	3.543
ESA3320NL90-42	Die set n. 42 - length 90 mm	42	42-45	90	3.543
ESA3320N100-45	Die set n. 45 - length 100 mm	45	45-48	100	3.937
ESA3320NL100-48	Die set n. 48 - length 100 mm	48	48-51	100	3.937
ESA3320N110-51	Die set n. 51 - length 110 mm	51	51-57	110	4.331
ESA3320N110-57	Die set n. 57 - length 110 mm	57	57-62	110	4.331
ESA3320N110-62	Die set n. 62 - length 110 mm	62	62-66	110	4.331
ESA3320N125-66	Die set n. 66 - length 110 mm	66	66-70	110	4.331
ESA3320N100-70	Die set n. 70 - length 100 mm	70	70-72	100	3.937
ESA3330NL100D072L2	Die set n. 72 - length 100 mm	72	72-73	100	3.937
ESA3330NL236D073L4	Die set n. 73 - length 125-28 mm, Reinforced Pin	73	73-76	125	4.921
ESA3540N125-76	Die set n. 76 - length 125 mm	76	76-86	125	4.921
ESA3440NL150D086L6	Die set n. 86 - length 150 mm	86	86-90	150	5.906
ESA3540N125-90F	Die set n. 90 - length 125 mm	90	90-95	125	4.921
ESA3440NL150D095L6	Die set n. 95 - length 150 mm	95	95-105	150	5.906
ESA3550NL150D105L	Die set n. 105 - length 150 mm	105	105-112	150	5.906
ESA3550NL150D112L	Die set n. 112 - length 150 mm	112	112-122	150	5.906
ESA3440NL130D122L5	Die set n. 122 - length 130 mm, Reinforced Pin	122	122 -130	130	5.118
ESA3550NL150D130L1	Die set n. 130 - length 145 mm	130	130-140	145	5.709
ESA3540N480KT	Kit 13 dies MS480 (n.15 to n.73)				
ESA3540N400KTF	Kit 20 dies MS480 (n.15 to n.76)				



# CRIMPING MACHINES

## MS 800

### ASSEMBLING FOR LARGE BORE HOSES STAND TYPE CRIMP MACHINE, SCS CONTROL



#### KEY ADVANTAGES

- Designed for heavy duty large bore hydraulic hoses
- High power and speed
- Ergonomically designed for large bore hoses
- Safe Crimp System (SCS) for maximum reliability during the crimping process
- Large opening up to 8"
- Long master dies
- Very high crimping force

#### MAIN APPLICATIONS

Dedicated to professional assemblers operating in off-shore, mining and giant hydraulics. This machine is designed for large bore, robust hoses - not advised for small bore hoses (DN 12 and smaller).

#### TECHNICAL SPECIFICATIONS

<b>Dimensions:</b>	1400 x 1400 x 2060 mm (55 x 55 x 81")	<b>Motor:</b>	7.5 kW
<b>Net Weight:</b>	4300 kg (9480 lb)	<b>Noise Level:</b>	< 70 dB A
<b>Packaging:</b>	Not available	<b>Crimp Range:</b>	4 - 230 mm (0.157 - 9.055")
<b>Gross Weight:</b>	5000 kg (11023 lb)	<b>Crimp Force:</b>	800 t
<b>Voltages:</b>	380/415 V, 3Ph, 50 Hz	<b>Opening with Dies:</b>	+100 mm (+3.937")
<b>Capacity:</b>	4ws: 4" max. 6ws: 3" max. 8ws: 3" max. Industrial: 8"	<b>Complete Opening:</b>	350 mm (13.779")
		<b>Master Die Length:</b>	180 mm (7.087")
		<b>Technical Features:</b>	- Machine platform equipped with rollers to support the hose at working height (1100 mm) in order to handle large bore hoses more easily - Supplied as standard: Intermediate dies 250/130 - Options available: Die storage panel, die size upon request

#### HOSE AND FITTING SELECTION

Hose Type	Fittings Type	Max. Hose Size	Ref. Hoses
4 Wire Spirals	MF2000 Multifit; MF2000 Interlock Plus; MF2000 Xtralock; MF2000 Spiralfit	4" with extra dies	Rockmaster (spiral); Shieldmaster (spiral); GoldenISO Xtraflex; Xtraflow/4WS; Goldenblast
6/8 Wire Spirals	MF2000 Interlock Plus; MF2000 Xtralock; MF2000 Interlock Super	>3" with extra dies	Diamondspir up to 3"; Rockmaster/13; Rockmaster/15
Industrial Textile Hoses	Various	8"	Spirtex/K; Others



Performances measured on a 400 V, 3Ph, 50 Hz network

# CRIMPING MACHINES

## MS 800

**ASSEMBLING FOR LARGE BORE HOSES**

**STAND TYPE CRIMP MACHINE, SCS CONTROL**

### ORDERING INFORMATION

Product Code	Description
EOA3434NMMS800	MS 800 SCS 380/415V 3PH 50HZ

### AVAILABLE DIE SETS

Product Code	Description	N°	Crimp Range	Die Length (mm)	Die Length (inch)
ESA3320NL90-39	Die set n. 39 - length 90 mm	39	39-42	90	3.543
ESA3320NL90-42	Die set n. 42 - length 90 mm	42	42-45	90	3.543
ESA3320N100-45	Die set n. 45 - length 100 mm	45	45-48	100	3.937
ESA3320NL100-48	Die set n. 48 - length 100 mm	48	48-51	100	3.937
ESA3430N110-51	Die set n. 51 - length 110 mm	51	51-57	110	4.331
ESA3430N110-57	Die set n. 57 - length 110 mm	57	57-62	110	4.331
ESA3320N110-62	Die set n. 62 - length 110 mm	62	62-66	110	4.331
ESA3330N125-66	Die set n. 66 - length 110 mm	66	66-70	110	4.331
ESA3320N100-70	Die set n. 70 - length 100 mm	70	70-72	100	3.937
ESA3330NL100D072L2	Die set n. 72 - length 100 mm	72	72-73	100	3.937
ESA3330NL125D073L4	Die set n. 73 - length 125-28 mm, Reinforced Pin	73	73-76	125	4.921
ESA3540N125-76	Die set n. 76 - length 125 mm	76	76-86	125	4.921
ESA3440NL150D086L6	Die set n. 86 - length 150 mm	86	86-90	150	5.906
ESA3540N125-90F	Die set n. 90 - length 125 mm	90	90-95	125	4.921
ESA3440NL150D095L6	Die set n. 95 - length 150 mm	95	95-105	150	5.906
ESA3530NL180D105L5	Die set n. 105 - length 180 mm	105	105-112	180	7.087
ESA3550NL150D112L	Die set n. 112 - length 150 mm	112	112-122	150	5.906
ESA3530NL180D130L5	Die set n. 130 - length 180 mm	130	130-140	180	7.087
ESA3540N800KTF	Kit 18 dies MS800 (n.39 to n.130)				

# CUTTING MACHINES

## M22 CUT STARTER WORKSHOP BENCHTOP



### KEY ADVANTAGES

- Smooth bending system
- 90° cut
- Clean cut
- Scalloped blade
- Dust collector included
- Multiple voltage options

### MAIN APPLICATIONS

Dedicated to repair shops or maintenance departments making low volumes of small and medium sized hose assemblies.

### TECHNICAL SPECIFICATIONS

<b>Dimensions:</b>	630 x 485 x 650 mm (25 x 19 x 26")	<b>Motor:</b>	2.2 kW
<b>Net Weight:</b>	42 kg (93 lb)	<b>Rotation Speed:</b>	3000 rpm
<b>Packaging:</b>	800 x 600 x 830 mm (31 x 24 x 33")	<b>Scalloped Blade Diameter:</b>	254 mm (10") included
<b>Gross Weight:</b>	55 kg (121 lb)	<b>Max. Hose OD:</b>	50 mm (1.969")
<b>Voltages:</b>	220/240 V, 3Ph, 50 Hz 380/415 V, 3Ph, 50 Hz 208/240 V, 3Ph, 60 Hz 380/415 V, 3Ph, 60 Hz	<b>Technical Features:</b>	- Dust collector included as standard - Dimensions van type machine: 488 x 630 x 650 mm (19.2 x 24.8 x 25.6"); 38 kg (84 lb)
<b>Capacity:</b>	2wb: 1 1/4" max. 4ws: 1 1/4" max.		

### HOSE AND FITTING SELECTION

Hose Type	Max. Hose Size	Ref. Hoses
2 Wire Braid & Textile	1 1/4"	Tractor; Harvester; Lyteflex; Pilot; Cover; Equator; Rockmaster (braided); Shieldmaster (braided); Astro; Multitex; Hydroplast;
4 Wire Spirals	1 1/4"	Rockmaster (spiral); GoldenISO Xtraflex



Performances measured on a 400 V, 3Ph, 50 Hz network

# CUTTING MACHINES

---

## M22 CUT

**STARTER WORKSHOP**

**BENCHTOP**

### ORDERING INFORMATION

Product Code	Description
EOC3114NCUT22P	M 22 CUT 380/415V 3PH 50HZ
EOC3117NCUT22P	M 22 CUT 220/240V 3PH 50HZ
EOC3119NCUT22P	M 22 CUT 208/240V 3PH 60HZ
EOC311BNCUT22P	M 22 CUT 380/415V 3PH 60HZ

### AVAILABLE ACCESSORIES

Product Code	Description
3012309	Cutting Disc Scalloped Style 250 mm

# CUTTING MACHINES

## M30 CUT E

**STARTER & PROFESSIONAL WORKSHOP**

**BENCHTOP CUTTING MACHINE, OPTIONAL SKIVING**

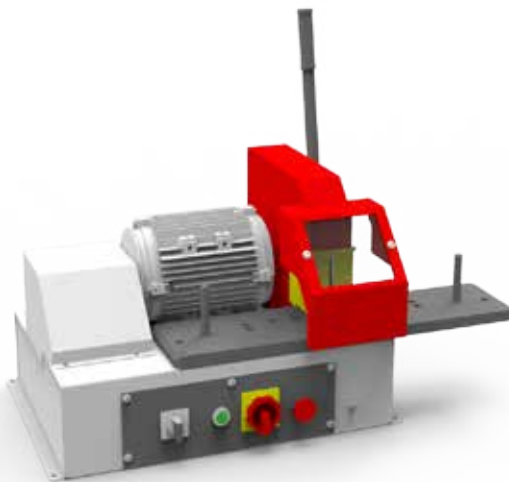

### KEY ADVANTAGES

- Compact design
- Easy and safe to use
- Versatile, scalloped blade for high performance and efficient cutting with minimal smoke
- Electronic brake
- Skiving module can be ordered as optional and integrated on this machine

### MAIN APPLICATIONS

**Benchtop machine for after-market service, container workshop or mobile van service and field repair. Also workshops for intermittent service.**

### TECHNICAL SPECIFICATIONS

<b>Dimensions:</b>	835 x 545 x 640 mm (33 x 21 x 25")	<b>Motor:</b>	3.0 kW
<b>Net Weight:</b>	75 kg (165 lb)	<b>Rotation Speed:</b>	3000 rpm
<b>Packaging:</b>	1170 x 770 x 1100 mm (46 x 30 x 43")	<b>Scalloped Blade Diameter:</b>	300 mm (11.8")
<b>Gross Weight:</b>	90 kg (198 lb)	<b>Max. Hose OD:</b>	85 mm (3.346")
<b>Voltages:</b>	220/240 V, 3Ph, 50 Hz 380/415 V, 3Ph, 50 Hz 208/240 V, 3Ph, 60 Hz 380/415 V, 3Ph, 60 Hz		
<b>Capacity:</b>	2wb: 2" max. 4ws: 2" max. 6ws: 1 1/4" max. Industrial: 2" max.		

### HOSE AND FITTING SELECTION

Hose Type	Max. Hose Size	Ref. Hoses
2 Wire Braid & Textile	2"	Tractor; Harvester; Lyteflex; Pilot; Cover; Equator; Rockmaster (braided); Shieldmaster (braided); Astro; Multitex; Hydroplast; Spirtex/K
4 Wire Spirals	2"	Rockmaster (spiral); Shieldmaster (spiral); GoldenISO Xtraflex; Goldenblast
6 Wire Spirals	1 1/4"	Rockmaster/13; Rockmaster/15; Diamondspir



Performances measured on a 400 V, 3Ph, 50 Hz network

# CUTTING MACHINES

---

## M30 CUT E

**STARTER & PROFESSIONAL WORKSHOP**

**BENCHTOP CUTTING MACHINE, OPTIONAL SKIVING**

### ORDERING INFORMATION

Product Code	Description
EOC3324NM30CUTE	M30 CUT E 380/415V 3PH 50HZ ECO
EOC3327NM30CUTE	M30 CUT E 220/240V 3PH 50HZ ECO
EOC3329NM30CUTE	M30 CUT E 208/240V 3PH 60HZ ECO
EOC332BNM30CUTE	M30 CUT E 380/415V 3PH 60HZ ECO

### AVAILABLE ACCESSORIES

Product Code	Description
3015126	Cutting Disc Scalloped Style 300 mm

# CUTTING MACHINES

## M30 CUT L

**STARTER AND PROFESSIONAL WORKSHOP  
STAND TYPE CUTTING MACHINE**



### KEY ADVANTAGES

- Compact design
- Easy and safe to use
- Versatile, scalloped blade for high performance and efficient cutting with minimal smoke
- Ergonomic, easy to clean
- Integrated dust collector

### MAIN APPLICATIONS

**Benchtop machine for after-market service, container workshop or mobile van service, field repair and intermittent service workshops.**

### TECHNICAL SPECIFICATIONS

<b>Dimensions:</b>	765 x 500 x 1150 mm (30 x 20 x 45")	<b>Motor:</b>	3.0 kW
<b>Net Weight:</b>	92 kg (203 lb)	<b>Rotation Speed:</b>	3000 rpm
<b>Packaging:</b>	800 x 600 x 1200 mm (32 x 24 x 47")	<b>Scalloped Blade Diameter:</b>	254 mm (10")
<b>Gross Weight:</b>	120 kg (265 lb)	<b>Max. Hose OD:</b>	85 mm (3.34")
<b>Voltages:</b>	220/240 V, 3Ph, 50 Hz 380/415 V, 3Ph, 50 Hz 208/240 V, 3Ph, 60 Hz 380/415 V, 3Ph, 60 Hz		
<b>Capacity:</b>	2wb: 2" max. 4ws: 2" max. 6ws: 1 1/4" max. Industrial: 2"		

### HOSE AND FITTING SELECTION

Hose Type	Max. Hose Size	Ref. Hoses
2 Wire Braid & Textile	2"	Tractor; Harvester; Lyteflex; Pilot; Cover; Equator; Rockmaster (braided); Shieldmaster (braided); Astro; Multitex; Hydroplast; Spirtex/K
4 Wire Spirals	2"	Rockmaster (spiral); Shieldmaster (spiral); GoldenISO Xtraflex; Goldenblast
6 Wire Spirals	1 1/4"	Rockmaster/13; Rockmaster/15; Diamondspir



Performances measured on a 400 V, 3Ph, 50 Hz network

# CUTTING MACHINES

---

## M30 CUT L

**STARTER AND PROFESSIONAL WORKSHOP**

**STAND TYPE CUTTING MACHINE**

### ORDERING INFORMATION

Product Code	Description
EOC3424NM30CUTL	M30 CUT L 380/415V 3PH 50HZ
EOC3427NM30CUTL	M30 CUT L 220/240V 3PH 50HZ

### AVAILABLE ACCESSORIES

Product Code	Description
3015309	Cutting Disc Scalloped Style 250 mm
ESC3440NCRL2M	Cutting Rail Length 2 M
ESC3440NCRL3M	Cutting Rail Length 3 M
ESC3440NJUCUR	Junction for Cutting Rail



# CUTTING MACHINES

## M30 CUT & SKIVE

STARTER & PROFESSIONAL WORKSHOP

**BENCHTOP, INTEGRATED CUTTING & SKIVING**



### KEY ADVANTAGES

- Compact design
- Two operations in one machine
- Easy and safe to use
- Versatile, scalloped blade for high performance and efficient cutting with minimal smoke
- Dust free skive operation (drawers for dust collection)
- Electronic brake

### MAIN APPLICATIONS

Benchtop machine for after-market service, container workshops or mobile van service. Also suitable for field repair and intermittent service workshops.

### TECHNICAL SPECIFICATIONS

<b>Dimensions:</b>	835 x 545 x 640 mm (33 x 21 x 25")	<b>Motor:</b>	3.0 kW
<b>Net Weight:</b>	85 kg (187 lb)	<b>Rotation Speed (Cut):</b>	3000 rpm
<b>Packaging:</b>	1170 x 770 x 1100 mm (46 x 30 x 43")	<b>Rotation Speed (Skive):</b>	200 rpm
<b>Gross Weight:</b>	100 kg (220 lb)	<b>Scalloped Blade Diameter:</b>	300 mm (11.8")
<b>Voltages:</b>	220/240 V, 3Ph, 50 Hz	<b>Max. Hose OD:</b>	85 mm (3.34")
	380/415 V, 3Ph, 50 Hz	<b>Technical Features:</b>	
	208/240 V, 3Ph, 60 Hz	Skiving tools: for External Skiving (ESE) and for Internal Skiving (IS) to be ordered separately	
	380/415 V, 3Ph, 60 Hz		
<b>Capacity:</b>	2wb: 2" max.		
	4ws: 2" max.		
	6ws: 1 1/4" max.		
	Industrial: 2" max.		

### HOSE AND FITTING SELECTION

Hose Type	Max. Hose Size	Ref. Hoses
2 Wire Braid & Textile	2"	Tractor; Harvester; Lyteflex; Pilot; Cover; Equator; Rockmaster (braided); Shieldmaster (braided); Astro; Multitex; Hydroplast; Spirtex/K
4 Wire Spirals	2"	Rockmaster (spiral); Shieldmaster (spiral); GoldenISO Xtraflex; Goldenblast
6 Wire Spirals	1 1/4"	Rockmaster/13; Rockmaster/15; Diamondspir



Performances measured on a 400 V, 3Ph, 50 Hz network

# CUTTING MACHINES

## M30 CUT & SKIVE

**STARTER & PROFESSIONAL WORKSHOP**

**BENCHTOP, INTEGRATED CUTTING & SKIVING**

### ORDERING INFORMATION

Product Code	Description
EOC3224NM30CUTSKY	M30 CUT/SKIVE 380/415V 3PH 50HZ
EOC3227NM30CUTSKY	M30 CUT/SKIVE 220/240V 3PH 50HZ
EOC3229NM30CUTSKY	M30 CUT/SKIVE 208/240V 3PH 60HZ
EOC322BNM30CUTSKY	M30 CUT/SKIVE 380/415V 3PH 60HZ

### AVAILABLE ACCESSORIES

Product Code	Description
ESS3430NKTESE	KIT ESE 6 TO 50 10 MANDRELS 1/4" TO 2"
ESS3430NKTIS	KIT IS 12/51 7 MANDRELS 1/2" TO 2"
ESS3430NIS10	IS 10 (3/8")
ESS3430NIS13	IS 13 (1/2")
ESS3430NIS16	IS 16 (5/8")
ESS3430NIS19	IS 19 (3/4")
ESS3430NIS25	IS 25 (1")
ESS3430NIS32	IS 32 (1"1/4)
ESS3430NIS38	IS 38 (1"1/2)
ESS3430NIS50	IS 50 (2")
3001795	Spare knife for ESE Ext Skiving 6/50 mm
3011245	Spare knife for internal tool diameter 13 & 16 mm
3011246	Spare knife for internal tool diameter 19 & 25 mm
3011247	Spare knife for internal tool diameter 32 & 38 mm
3011248	Spare knife for internal tool diameter 50 mm
3015126	Cutting Disc Scalloped Style 300 mm

# CUTTING MACHINES



## M55 CUT

**FULL SERVICE WORKSHOP, STARTER PRODUCTION UNITS**  
**STAND TYPE CUTTING MACHINE**

### KEY ADVANTAGES

- Versatile, scalloped blade for high performance smoke free cutting
- Ergonomic and functional design
- Double foot pedal system
- Safety cover and feeding guides for hose (easy and fast cutting operation)
- Digital counter for maintenance assistance

### MAIN APPLICATIONS

Stand type hose cutting machine for professional service workshops and after-market service. With pneumatic bending option it is suitable for small/medium OEM productions. This is a versatile machine, suitable for hoses up to 2" (intermittent service).

### TECHNICAL SPECIFICATIONS

<b>Dimensions:</b>	1140 x 1000 x 1280 mm (45 x 39 x 50")	<b>Motor:</b>	7.5 kW
<b>Net Weight:</b>	240 kg (529 lb)	<b>Rotation Speed:</b>	3000 rpm
<b>Packaging:</b>	1600 x 1200 x 1600 mm (63 x 47 x 63")	<b>Scalloped Blade Diameter:</b>	400 mm (15.7")
<b>Gross Weight:</b>	280 kg (617 lb)	<b>Max. Hose OD:</b>	80 mm (3.15")
<b>Voltages:</b>	220/240 V, 3Ph, 50 Hz 380/415 V, 3Ph, 50 Hz 208/240 V, 3Ph, 60 Hz 380/415 V, 3Ph, 60 Hz	<b>Technical Features:</b>	- Diameter of the suction connection: 150 mm (6") - Options: Pneumatic bending system, OEM slotted blade
<b>Capacity:</b>	2wb: 2" max. 4ws: 2" max. 6ws: 2" max. Industrial: 2"		

### HOSE AND FITTING SELECTION

Hose Type	Max. Hose Size	Ref. Hoses
2 Wire Braid & Textile	2"	Tractor; Harvester; Lyteflex; Pilot; Cover; Equator; Rockmaster (braided); Shieldmaster (braided); Astro; Multitex; Hydroplast; Spirtex/K
4 Wire Spirals	2"	Rockmaster (spiral); Shieldmaster (spiral); GoldenISO Xtraflex; Goldenblast
6 Wire Spirals	2"	Rockmaster/13; Rockmaster/15; Diamondspir



Performances measured on a 400 V, 3Ph, 50 Hz network

# CUTTING MACHINES

## M55 CUT

**FULL SERVICE WORKSHOP, STARTER PRODUCTION UNITS**

**STAND TYPE CUTTING MACHINE**

### ORDERING INFORMATION

Product Code	Description
EOC3434NCUT55	M55 CUT 380/415V 3PH+N 50HZ
EOC3434NCUT55SK	M55 CUT 380/415V 3PH+N 50HZ SUCTION
EOC3437NMCUT55	M55 CUT 220/240V 3PH 50HZ
EOC3437NMCUT55SK	M55 CUT 220/240V 3PH 50HZ SUCTION
EOC3339NMCUT55	M55 CUT 208/240V 3PH 60HZ
EOC3339NMCUT55SK	M55 CUT 208/240V 3PH 60Hz SUCTION
EOC343BNMCUT55	M55 CUT 380/415V 3PH+N 60HZ
EOC343BNMCUT55SK	M55 CUT 380/415V 3PH+N 60HZ SUCTION

### AVAILABLE ACCESSORIES

Product Code	Description
3016443	Cutting Disc Scalloped Style 400 mm
3021317	OEM Cutting Disc Slotted Style 400 mm
ESC3440NCRL2M	Cutting Rail Length 2 M
ESC3440NCRL3M	Cutting Rail Length 3 M
ESC3440NJUCUR	Junction for Cutting Rail

# CUTTING MACHINES



## M75 CUT

EXPERT SERVICE LINE

STAND TYPE CUTTING MACHINE

### KEY ADVANTAGES

- Powerful
- Safety cover
- High visibility
- Suitable for cutting large bore hoses

### MAIN APPLICATIONS

Dedicated to hydraulic maintenance specialists working on medium and large size machines and equipment. Also suitable for small OEM suppliers.

### TECHNICAL SPECIFICATIONS

<b>Dimensions:</b>	910 x 820 x 1280 mm (36 x 32 x 50")	<b>Motor:</b>	7.5 kW
<b>Net Weight:</b>	215 kg (474 lb)	<b>Rotation Speed:</b>	3000 rpm
<b>Voltages:</b>	220/240 V, 3Ph, 50 Hz	<b>Scalloped Blade Diameter:</b>	520 mm (20.5") included
	380/415 V, 3Ph, 50 Hz	<b>Max. Hose OD:</b>	125 mm (5")
	208/240 V, 3Ph, 60 Hz	<b>Technical Features:</b>	
	380/415 V, 3Ph, 60 Hz	- Diameter of suction connection:	110 mm (4.33 ")
<b>Capacity:</b>	2wb: 3" max.	- Optional tool: Brake motor, serrated disc, OEM slotted disc	
	4ws: 2" max.		
	6ws: 2" max.		

### HOSE AND FITTING SELECTION

Hose Type	Max. Hose Size	Ref. Hoses
2 Wire Braid & Textile	3"	Tractor; Harvester; Lyteflex; Pilot; Cover; Equator; Rockmaster (braided); Shieldmaster (braided); Astro; Multitex; Hydroplast
4 Wire Spirals	2"	Rockmaster (spiral); Shieldmaster (spiral); GoldenISO Xtraflex
6 Wire Spirals	2"	Diamondspir up to 2"; Rockmaster/13; Rockmaster/15



Performances measured on a 400 V, 3Ph, 50 Hz network

# CUTTING MACHINES

## M75 CUT

**EXPERT SERVICE LINE**

**STAND TYPE CUTTING MACHINE**

### ORDERING INFORMATION

Product Code	Description
EOC3334NCUT75	M75 CUT 380/415V 3PH 50HZ
EOC3334NM75BM	M75 CUT 380/415V 3PH 50HZ Brake motor
EOC3337NCUT75	M75 CUT 220/240V 3PH 50HZ
EOC3339NCUT75	M75 CUT 208/240V 3PH 60HZ
EOC3339NCUT75F	M75 CUT 208/240V 3PH 60HZ BRAKE

### AVAILABLE ACCESSORIES

Product Code	Description
3016797	Cutting Disc Scalloped Style 520 mm
3021075	OEM Cutting Disc Slotted Style 520 mm
ESC3440NCRL2M	Cutting Rail Length 2 M
ESC3440NCRL3M	Cutting Rail Length 3 M
ESC3440NJUCUR	Junction for Cutting Rail

# CUTTING MACHINES



## M90 CUT

EXPERT SERVICE LINE

STAND TYPE CUTTING MACHINE

### KEY ADVANTAGES

- Very powerful
- Heavy duty for difficult cuts
- Hydraulic bending
- Brake motor
- Electronic soft start

### MAIN APPLICATIONS

Dedicated to professional assemblers, large OEM suppliers and special applications.

### TECHNICAL SPECIFICATIONS

**Dimensions:** 1000 x 1060 x 1350 mm (39 x 42 x 53")

**Net Weight:** 260 kg (573 lb)

**Voltages:** 220/240 V, 3Ph, 50 Hz

380/415 V, 3Ph, 50 Hz

208/240 V, 3Ph, 60 Hz

380/415 V, 3Ph, 60 Hz

**Capacity:** 2wb: 3½" max.

4ws: 3½" max.

6ws: 3" max.

**Motor:** 9.0 kW

**Rotation Speed:** 3000 rpm

**Scalloped Blade Diameter:** 520 mm (20.5") included

**Max. Hose OD:** 125 mm (5")

#### Technical Features:

- Diameter of suction connection: 110 mm (4.33")

- Standard tool: Hydraulic bending, brake motor

- Optional tool: Serrated disc, OEM slotted disc

### HOSE AND FITTING SELECTION

Hose Type	Max. Hose Size	Ref. Hoses
2 Wire Braid & Textile	3½"	Tractor; Harvester; Lyteflex; Pilot; Cover; Equator; Rockmaster (braided); Shieldmaster (braided); Astro; Multitex; Hydroplast; Xtraflow
4 Wire Spirals	3½"	Rockmaster (spiral); Shieldmaster (spiral); GoldenISO Xtraflex; Xtraflow/4WS
6 Wire Spirals	3" (21 MPa type)	Diamondspir (up to 3")



Performances measured on a 400 V, 3Ph, 50 Hz network

# CUTTING MACHINES

## M90 CUT

**EXPERT SERVICE LINE**

**STAND TYPE CUTTING MACHINE**

### ORDERING INFORMATION

Product Code	Description
EOC3444NCUT90	M90 CUT 380/415V 3PH 50HZ
EOC3444NCUT90HP	M90 CUT 380/415V 3PH 50HZ HIGH PROD
EOC3447NCUT90	M90 CUT 220/240V 3PH 50HZ
EOC3449NCUT90	M90 CUT 208/240V 3PH 60HZ
EOC344BNCUT90	M90 CUT 380/415V 3PH 60HZ

### AVAILABLE ACCESSORIES

Product Code	Description
3016797	Cutting Disc Scalloped Style 520 mm
3021075	OEM Cutting Disc Slotted Style 520 mm
3002792	Cutting Disc Serrated Style
ESC3440NCRL2M	Cutting Rail Length 2 M
ESC3440NCRL3M	Cutting Rail Length 3 M
ESC3440NJUCUR	Junction for Cutting Rail



# SKIVING MACHINES

**MH SKY**

**FIELD SERVICE & MOBILE WORKSHOP**

**MANUAL, PORTABLE SKIVING TOOL**



## KEY ADVANTAGES

- Portable, lightweight
- Economic
- Simple
- Compact
- Robust
- Plug'n skive system

## MAIN APPLICATIONS

Dedicated to small repair shops and maintenance departments making low volumes of hose assemblies a day. Also ideal for carrying out on-site repairs or for placement in a service van.

## TECHNICAL SPECIFICATIONS

**Dimensions:** 413 x 52 x 224 mm (16 x 2 x 9")

**Net Weight:** 3 kg (7 lb)

**Capacity:** 2wb: 2" max.

4ws: 2" max.

### Technical Features:

- Tool selection:

External Skiving Kit (ESE) including 10 mandrels (6-8-10-13-16-19-25-32-38-50)

Internal Skiving Kit (IS) including 7 mandrels (13-16-19-25-32-38-50)

Internal skiving tools can also be ordered per diameter

## HOSE AND FITTING SELECTION

Hose Type	Max. Hose Size	Ref. Hoses
2 Wire Braid & Textile	2"	Tractor; Harvester; Lyteflex; Pilot; Cover; Equator; Rockmaster (braided); Shieldmaster (braided); Astro; Multitex; Hydroplast
4 Wire Spirals	2"	Rockmaster (spiral); Shieldmaster (spiral); GoldenISO Xtraflex

# SKIVING MACHINES

## MH SKY

**FIELD SERVICE & MOBILE WORKSHOP**

**MANUAL, PORTABLE SKIVING TOOL**

### ORDERING INFORMATION

Product Code	Description
EOS3410NHSK	MH SKY HAND SKIVING TOOL

### AVAILABLE ACCESSORIES

Product Code	Description
ESS3430NKTESE	KIT ESE 6 TO 50 10 MANDRELS 1/4" TO 2"
ESS3430NKTIS	KIT IS 12/51 7 MANDRELS 1/2" TO 2"
ESS3430NIS10	IS 10 (3/8")
ESS3430NIS13	IS 13 (1/2")
ESS3430NIS16	IS 16 (5/8")
ESS3430NIS19	IS 19 (3/4")
ESS3430NIS25	IS 25 (1")
ESS3430NIS32	IS 32 (1"1/4)
ESS3430NIS38	IS 38 (1"1/2)
ESS3430NIS50	IS 50 (2")
3001795	Spare knife for ESE Ext Skiving 6/50 mm
3011245	Spare knife for internal tool diameter 13 & 16 mm
3011246	Spare knife for internal tool diameter 19 & 25 mm
3011247	Spare knife for internal tool diameter 32 & 38 mm
3011248	Spare knife for internal tool diameter 50 mm

# SKIVING MACHINES

## M50 SKY

**SMALL SERVICE WORKSHOP  
BENCHTOP SKIVING**

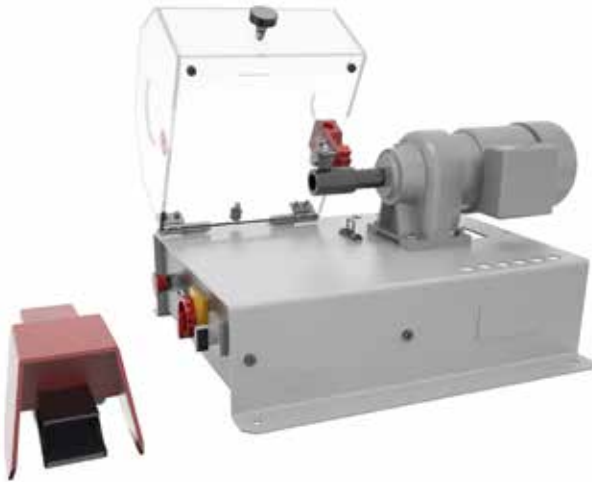

### KEY ADVANTAGES

- Plug'n skive system
- Compact & stable
- Safety switch on the cover
- Good visibility
- Tool storage included
- Foot pedal drive with emergency stop
- 2-way rotation

### MAIN APPLICATIONS

**Dedicated to hydraulic maintenance specialists working on medium sized machines and equipment. Also suitable for assemblers involved in medium sized hose assemblies and quantities.**

### TECHNICAL SPECIFICATIONS

<b>Dimensions:</b>	500 x 660 x 360 mm (19 x 26 x 14")	<b>Capacity:</b>	2wb: 2" max.
<b>Net Weight:</b>	45 kg (99 lb)		4ws: 2" max.
<b>Packaging:</b>	800 x 600 x 830 (31 x 24 x 33")	<b>Motor:</b>	0.25 kW
<b>Gross Weight:</b>	55 kg (121 lb)	<b>Rotation Speed:</b>	100 rpm
<b>Voltages:</b>	220/240 V, 1Ph, 50 Hz	<b>Technical Features:</b>	
	380/415 V, 3Ph, 50 Hz		Tools available (to be ordered separately) ESE, IS, ESP1, ESP2
	220/240 V, 1Ph, 60 Hz		
	380/415 V, 3Ph, 60 Hz		

### HOSE AND FITTING SELECTION

Hose Type	Max. Hose Size	Ref. Hoses
2 Wire Braid & Textile	2"	Tractor; Harvester; Lyteflex; Pilot; Cover; Equator; Rockmaster (braided); Shieldmaster (braided); Astro; Multitex; Hydroplast
4 Wire Spirals	2"	Rockmaster (spiral); Shieldmaster (spiral); GoldenISO Xtraflex

# SKIING MACHINES

## M50 SKY

SMALL SERVICE WORKSHOP

**BENCHTOP SKIVING**

### ORDERING INFORMATION

Product Code	Description
EOS3434N50PSK	M50 SKY 380/415V 3PH 50HZ
EOS3437N50PSK	M50 SKY 220/240V 3PH 50HZ
EOS3439N50PSK	M50 SKY 208/240V 3PH 60HZ
EOS343BN50PSK	M50 SKY 380/415V 3PH 60HZ

### AVAILABLE ACCESSORIES

Product Code	Description
ESS3430NKTESE	KIT ESE 6 TO 50 10 MANDRELS 1/4" TO 2"
ESS3430NKTIS	KIT IS 12/51 7 MANDRELS 1/2" TO 2"
ESS3430NIS10	IS 10 (3/8")
ESS3430NIS13	IS 13 (1/2")
ESS3430NIS16	IS 16 (5/8")
ESS3430NIS19	IS 19 (3/4")
ESS3430NIS25	IS 25 (1")
ESS3430NIS32	IS 32 (1"1/4)
ESS3430NIS38	IS 38 (1"1/2)
ESS3430NIS50	IS 50 (2")
ESS3430NKTESP	KIT ESP 06/51 10 MANDRELS 1/4" TO 2"
ESS3430NESP5	ESP 05 (3/16")
ESS3430NESP6	ESP 06 (1/4")
ESS3430NESP8	ESP 08 (5/16")
ESS3430NESP10	ESP 10 (3/8")
ESS3430NESP12	ESP 12 (1/2")
ESS3430NESP16	ESP 16 (5/8")
ESS3430NESP19	ESP 19 (3/4")
ESS3430NESP25	ESP 25 (1")
ESS3430NESP31	ESP 31 (1"1/4)
ESS3430NESP38	ESP 38 (1"1/2)
ESS3430NESP51	ESP 51 (2")
ESS3220NMESP19F	ESP 19 FORESTMASTER HOSE
ESS3220NMESP25F	ESP 25 FORESTMASTER HOSE
ESS3430N2KNESP	KIT 2ND KNIFE FOR ESP
3001795	Spare knife for ESE Ext Skiving 6/50 mm
3011245	Spare knife for internal tool diameter 13 & 16 mm
3011246	Spare knife for internal tool diameter 19 & 25 mm
3011247	Spare knife for internal tool diameter 32 & 38 mm
3011248	Spare knife for internal tool diameter 50 mm

# SKIVING MACHINES



## M205 SKY

EXPERT SERVICE LINE

STAND TYPE SKIVING MACHINE

### KEY ADVANTAGES

- Plug'n skive system
- Large dust collector
- Robust & easily adjustable knife for quick and easy changeover
- Suitable for high volume production
- 2-way rotation

### MAIN APPLICATIONS

Dedicated to professional assemblers, large OEM suppliers and special applications.

### TECHNICAL SPECIFICATIONS

<b>Dimensions:</b>	675 x 550 x 1130 mm (27 x 22 x 44")	<b>Motor:</b>	0.9 kW
<b>Net Weight:</b>	100 kg (220 lb)	<b>Speed Rotation:</b>	205 rpm
<b>Packaging:</b>	800 x 600 x 1200 mm (32 x 24 x 47")	<b>Technical Features:</b>	- Options available: speed regulator, hose clamping system (limited to distribution workshop using sizes under 2")
<b>Gross Weight:</b>	160 kg (353 lb)		- Tools available (to be ordered separately): ESA, IS, ESP1, ESP2
<b>Voltages:</b>	220/240 V, 3Ph, 50 Hz 380/415 V, 3Ph, 50 Hz 208/240 V, 3Ph, 60 Hz 380/415 V, 3Ph, 60 Hz		
<b>Capacity:</b>	2wb: 2" max. 4ws: 2" max. 6ws: 3" max. with original tools		

### HOSE AND FITTING SELECTION

Hose Type	Max. Hose Size	Ref. Hoses
2 Wire Braid & Textile	3" with optional skiving tool	Tractor; Harvester; Lyteflex; Pilot; Cover; Equator; Rockmaster (braided); Shieldmaster (braided); Astro; Multitex; Hydroplast
4 Wire Spirals	3" with optional skiving tool	Rockmaster (spiral); Shieldmaster (spiral); GoldenISO Xtraflex
6 Wire Spirals	3" with optional skiving tool	Diamondspir; Rockmaster/15

# SKIING MACHINES

## M205 SKY

**EXPERT SERVICE LINE**

**STAND TYPE SKIING MACHINE**

### ORDERING INFORMATION

Product Code	Description
EOS3434N205PSK	M205 SKY 380/415V 3PH 50HZ W/O ADJ.SPEED
EOS3434N205PSKRSA	M205 SKY 380/415V 50/60HZ W / ADJ. SPEED
EOS3327NM205PRSA	M205 SKY 208/240V 3PH 50/60Hz /adj.speed
EOS3437N205PSK	M205 SKY 220/240V 3PH 50HZ W/O AJD. SPEED
EOS343BN205PSK	M205 SKY 380/415V 3PH 60HZ W/O ADJ. SPEED

### AVAILABLE ACCESSORIES

Product Code	Description
ESS3430NKTESA	KIT ESA Ext Skiing - 11 mandrels 5/50 (5/6/8/10/13/16/19/25/32/38/50) M205 SKY PLUS
ESS3430NKTIS	KIT IS 12/51 7 MANDRELS 1/2' TO 2"
ESS3430NIS10	IS 10 (3/8")
ESS3430NIS13	IS 13 (1/2")
ESS3430NIS16	IS 16 (5/8")
ESS3430NIS19	IS 19 (3/4")
ESS3430NIS25	IS 25 (1")
ESS3430NIS32	IS 32 (1"1/4)
ESS3430NIS38	IS 38 (1"1/2)
ESS3430NIS50	IS 50 (2")
ESS3430NIS63	IS 63 (2"1/2) for M205 SKY+
ESS3430NIS76	IS 76 (3") for M205 SKY+
ESS3430NKTESP	KIT ESP 06/51 10 MANDRELS 1/4" TO 2"
ESS3430NESP5	ESP 05 (3/16")
ESS3430NESP6	ESP 06 (1/4")
ESS3430NESP8	ESP 08 (5/16")
ESS3430NESP10	ESP 10 (3/8")
ESS3430NESP12	ESP 12 (1/2")
ESS3430NESP16	ESP 16 (5/8")
ESS3430NESP19	ESP 19 (3/4")
ESS3430NESP25	ESP 25 (1")
ESS3430NESP31	ESP 31 (1"1/4)
ESS3430NESP38	ESP 38 (1"1/2)
ESS3430NESP51	ESP 51 (2")
ESS3430NESP63	ESP 63 (2"1/2)
ESS3430NESP76	ESP 76 (3")
ESS3430N2KNESP	KIT 2ND KNIFE FOR ESP
ESS3220NMESP19F	ESP 19 FORESTMASTER HOSE
ESS3220NMESP25F	ESP 25 FORESTMASTER HOSE
3011245	Spare knife for internal tool diameter 13 & 16 mm
3011246	Spare knife for internal tool diameter 19 & 25 mm
3011247	Spare knife for internal tool diameter 32 & 38 mm
3011248	Spare knife for internal tool diameter 50
3011221	Spare knife for external skiing for M205 SKY

# MARKING MACHINES



## M50 MARK

AFTER MARKET SERVICE

**BENCHTOP, FERRULE MARKING**

### KEY ADVANTAGES

- Robust
- Easy to use
- Compact
- Large space for 14 stamps

### MAIN APPLICATIONS

**Dedicated to repair shops and distributors for marking low volumes of ferrules.**

### TECHNICAL SPECIFICATIONS

**Dimensions:** 390 x 360 x 520 mm (15 x 14 x 20")

**Net Weight:** 34 kg (75 lb)

**Packaging:** 800 x 600 x 830 mm (31 x 24 x 33")

**Gross Weight:** 50 kg (110 lb)

**Capacity:** 2wb: 4" max.

4ws: 4" max.

**Standard stamp holder:** 2 x 14 stamps

**Size of the stamps:** 6 x 3 mm (0.236 x 0.118")

**Height of the letters:** 2.5 mm (0.098")

#### Technical Features:

Optional stamp holder with numbering wheel: 3 figures on the wheel and one groove for 10 stamps

#### Stamp Box Containing:

Letters (quantity in brackets): A(3), B(2), C(2), D(2), E(4), F(2), G(2), H(2), I(3), J(2), K(2), L(3), M(2), N(2), O(1), P(2), Q(1), R(3), S(3), T(2), U(3), V(2), W(1), X(1), Y(1), Z(1)

Numbers (quantity in brackets): 0(3), 1(3), 2(4), 3(4), 4(4), 5(3), 6(3), 7(3), 8(3), 9(3)

Signs (quantity in brackets): / (2), , (2), - (2), . (2)

# MARKING MACHINES

---

## M50 MARK

**AFTER MARKET SERVICE**

**BENCHTOP, FERRULES MARKING**

### ORDERING INFORMATION

Product Code	Description
EOM3120N	M50 MARK MANUAL MARKING MACHINE

### AVAILABLE ACCESSORIES

Product Code	Description
ESM3220NTCOF120PB	Box with 120 characters (letters and numbers)
ESM3220NTPOINCBRUT	Characters 6 x 3 mm (to be indicated)
3011158	Numbering wheel with 3 figures M50 MARK
3003814	Blank character M 50 MARK



# INSERT PUSHING MACHINES

## M1500 INS

EXPERT SERVICE LINE

**BENCHTOP COUPLING INSERTER**



### KEY ADVANTAGES

- Compact
- Sturdy
- Powerful

### MAIN APPLICATIONS

Dedicated to assemblers involved in relevant productions and professional workshops.

### TECHNICAL SPECIFICATIONS

<b>Dimensions:</b>	750 x 660 x 300 mm (30 x 26 x 12")	<b>Power Supply:</b>	compressed air (7 bar)
<b>Net Weight:</b>	70 kg (154 lb)	<b>Technical Features:</b>	
<b>Capacity:</b>	2ws: 2" max. 4ws: 2" max. 6ws: 2" max.	Optional tool: for small bore 1/4", 3/8", 1/2" shell	

### HOSE AND FITTING SELECTION

Hose Type	Fittings Type	Max. Hose Size	Ref. Hoses
2 Wire Braid & Textile	MF2000 Multifit; MF3000 OPF; MF3000 OPK	2"	Tractor; Harvester; Lyteflex; Pilot; Cover; Equator; Rockmaster (braided); Shieldmaster (braided); Astro; Multitex; Hydroplast
4 Wire Spirals	MF2000 Multifit; MF2000 Interlock Plus; MF3000 OPK; MF2000 Spiralfit	2"	Rockmaster (spiral); Shieldmaster (spiral); GoldenISO Xtraflex
6 Wire Spirals	MF2000 Xtralock; MF2000 Interlock Plus	2"	Diamondspir (up to 2")

# INSERT PUSHING MACHINES

---

## M1500 INS

**EXPERT SERVICE LINE**

***BENCHTOP COUPLING INSERTER***

### ORDERING INFORMATION

Product Code	Description
EOI3430S1500I	M1500 INS (COUPLING INSERTER ½" to 2")

# TEST BENCHES

## MTB 1500

**TEST BENCH, PROOF PRESSURE & CERTIFY  
STAND TYPE MACHINE**



### KEY ADVANTAGES

- Large testing area for up to 5 hoses
- 2 manometers: 0 - 400 bar for precision reading and 0 - 1500 bar for high pressure
- Double safety interlock on the lid to turn the pressure off when opening
- Test assemblies up to 1500 bar (see MTB 2500)

### MAIN APPLICATIONS

**Dedicated to assemblers involved in limited quantities of high pressure hoses. Recommended for professional workshops.**

### TECHNICAL SPECIFICATIONS

<b>Dimensions:</b>	2500 x 800 x 1050 mm (98 x 31 x 41")	<b>Max. Pressure</b>	21755 psi
<b>Net Weight:</b>	175 kg (386 lb)	<b>Technical Features:</b>	
<b>Packaging:</b>	2360 x 1130 x 1330 mm (93 x 44 x 52")	Compressed air input 7 bar (100 psi)	
<b>Gross Weight:</b>	330 kg (728 lb)		
<b>Capacity:</b>	Wide hose range		

### HOSE AND FITTING SELECTION

Hose Type	Max. Hose Size	Ref. Hoses
2 Wire Braid & Textile	2"	Tractor; Harvester; Lyteflex; Pilot; Cover; Equator; Rockmaster (braided); Shieldmaster (braided); Astro; Multitex; Hydroplast
4 Wire Spirals	2"	Rockmaster (spiral); Shieldmaster (spiral); GoldenISO Xtraflex
6 Wire Spirals	2"	Diamondspir (up to 2"); Goldenblast/Six; Rockmaster/13; Rockmaster/15

# TEST BENCHES

---

## MTB 1500

**TEST BENCH, PROOF PRESSURE & CERTIFY**

**STAND TYPE MACHINE**

### ORDERING INFORMATION

Product Code	Description
EOT3420SMTB1500	MTB 1500 BAR (STATIC TEST RIG- ¼" to 2")
EOT3420SMTB1500TSD	MTB 1500 WITH TSD & PRINTER

### AVAILABLE ACCESSORIES

Product Code	Description
EST3433NMTBLIGHT	Optional internal light - MTB1500/2500
EST3433NMTBEMU	Optional emulsion test (40 liter tank)

# TEST BENCHES

## MTB 2500

**TEST BENCH, PROOF PRESSURE & CERTIFY  
STAND TYPE MACHINE**



### KEY ADVANTAGES

- Large testing area for up to 5 hoses
- 2 manometers: 0 - 400 bar for precision reading and 0 - 2500 bar for high pressure
- Double safety interlock on the lid to turn the pressure off when opening
- Test assemblies up to 2500 bar

### MAIN APPLICATIONS

**Dedicated to assemblers involved in limited quantities of high pressure hoses. Recommended for professional workshops.**

### TECHNICAL SPECIFICATIONS

**Dimensions:** 2500 x 800 x 1050 mm (98 x 31 x 41")  
**Net Weight:** 175 kg (386 lb)  
**Packaging:** 2360 x 1130 x 1330 mm (93 x 44 x 52")  
**Gross Weight:** 330 kg (728 lb)  
**Capacity:** Wide hose range  
**Max. Pressure:** 36259 psi

### Technical Features:

- Compressed air input 7 bar (100 psi)
- Minimum compressed air input: 7 bar with minimum air flow 1000 l/min (dry air)
- Standard fluid used for tests: filtered water; minimum inlet pressure 3 bar
- Options available: computer and printer for test report, internal light, second pump for low pressure, test with emulsion in filtered closed circuit

### HOSE AND FITTING SELECTION

Hose Type	Max. Hose Size	Ref. Hoses
2 Wire Braid & Textile	2"	Tractor; Harvester; Lyteflex; Pilot; Cover; Equator; Rockmaster (braided); Shieldmaster (braided); Astro; Multitex; Hydroplast
4 Wire Spirals	2"	Rockmaster (spiral); Shieldmaster (spiral); GoldenISO Xtraflex
6 Wire Spirals	2"	Diamondspir (up to 2"); Goldenblast/Six; Rockmaster/13; Rockmaster/15

# TEST BENCHES

---

## MTB 2500

**TEST BENCH, PROOF PRESSURE & CERTIFY**

**STAND TYPE MACHINE**

### ORDERING INFORMATION

Product Code	Description
EOT3420SMTB2500TSD	MTB 2500 WITH TSD & PRINTER
EOT3430SMTB2500	MTB 2500 BAR (STATIC TEST RIG 1/4" to 2")

### AVAILABLE ACCESSORIES

Product Code	Description
EST3433NMTBLIGHT	Optional internal light - MTB1500/2500
EST3433NMTBEMU	Optional emulsion test (40 litre tank)

# ACCESSORIES AND TOOLS

## CUTTING DISCS

### Preferred blade type as standard:

The scalloped blade is suitable for all hose types. It is the optimum solution for the whole hose range and is able to reach a high quality of cutting surface.

### Alternative blade type:

The serrated disc is recommended for cutting small bore wire braided hoses (up to DN 31), and is also suitable for cutting spiral hoses.

### High performance blade type:

The slotted blade is recommended for cutting standard and heavy duty hoses. It is ideal for continuous service, as the blade profile has been optimised to maintain a low temperature on the cutting edge. It is dedicated to OEM assembling.

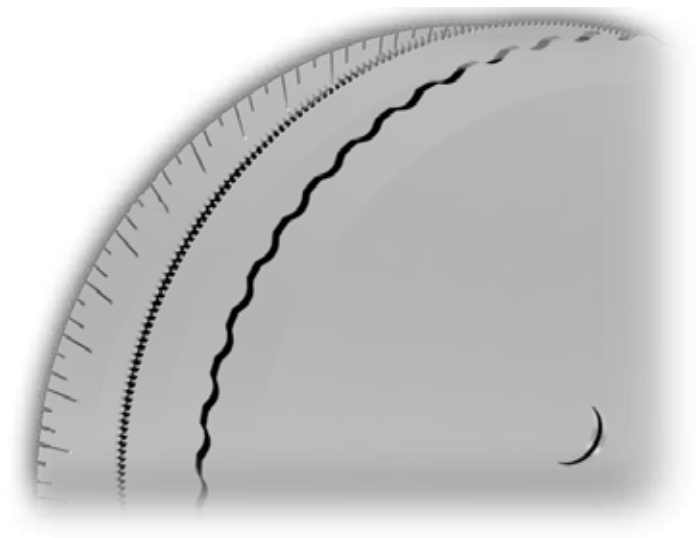

## BRAKE MOTOR

The brake motor is a safety device - when the stop button is pushed, the disc stops immediately.

## PNEUMATIC BENDING

### AVAILABLE ON M75 CUT AND M55 CUT

Pneumatic bending facilitates cutting, as the operator does not have to force the hose on the blade. The pneumatic system, activated by a foot switch, offers hands free operation. This is the same principle for the hydraulic bending on M90 CUT.

## HOSE CLAMPING SYSTEM

Recommended for skiving hoses over 2" (DN 50)

# ACCESSORIES AND TOOLS

## SKIVING MACHINES

All Manuli skiving machines are equipped with the Plug'n Skive System which allows the quick and easy insertion of tools.

With the Plug n'Skive System no tools are needed to insert the skiving mandrel, simply push the mandrel into the locking system to unlock it, lift a knob and pull out the tool.

## EXTERNAL SKIVING TOOLS

Depending on the machine and on customer needs, Manuli offers 3 types of external skiving tools:

### ESE (EXTERNAL SKIVING ECONOMIC)

**FOR MH SKY, M50 SKY AND M30 CUT & SKIVE**

The ESE kit includes 10 mandrels:  $\frac{1}{4}$ " ,  $\frac{5}{16}$ " ,  $\frac{3}{8}$ " ,  $\frac{1}{2}$ " ,  $\frac{5}{8}$ " ,  $\frac{3}{4}$ " , 1" , 1 $\frac{1}{4}$ " , 1 $\frac{1}{2}$ " , 2"

### ESA (EXTERNAL SKIVING ADJUSTABLE)

**FOR M205 SKY**

The ESA kit includes 11 mandrels:  $\frac{3}{16}$ " ,  $\frac{1}{4}$ " ,  $\frac{5}{16}$ " ,  $\frac{3}{8}$ " ,  $\frac{1}{2}$ " ,  $\frac{5}{8}$ " ,  $\frac{3}{4}$ " , 1" , 1 $\frac{1}{4}$ " , 1 $\frac{1}{2}$ " , 2"

ESA mandrels are also available in 2 $\frac{1}{2}$ " and 3"

### ESP (EXTERNAL SKIVING PRODUCTION)

**FOR M50 SKY AND M205 SKY**

ESP tools are individual 'skiving heads' intended to be pre-set to the right depth and length for greater productivity. They are recommended for batch skiving operations and a second knife can be added for abrasion resistant covers.

ESP is available in:  $\frac{3}{16}$ " ,  $\frac{1}{4}$ " ,  $\frac{5}{16}$ " ,  $\frac{3}{8}$ " ,  $\frac{1}{2}$ " ,  $\frac{5}{8}$ " ,  $\frac{3}{4}$ " , 1" , 1 $\frac{1}{4}$ " , 1 $\frac{1}{2}$ " , 2" , 2 $\frac{1}{2}$ " , 3"



*ESE skiving tools*



# ACCESSORIES AND TOOLS

---

## INTERNAL SKIVING TOOLS

### IS (INTERNAL SKIVING)

#### FOR ALL MACHINES

The IS kit includes 7 mandrels:  $\frac{1}{2}$ " ,  $\frac{5}{8}$ " ,  $\frac{3}{4}$ " , 1" ,  $1\frac{1}{4}$ " ,  $1\frac{1}{2}$ " , 2"

They are also available in  $\frac{3}{8}$ " ,  $2\frac{1}{2}$ " and 3"

The ring is heat treated to resist the abrasion of the hose wires.



# ACCESSORIES AND TOOLS

## SAFE CRIMP SYSTEM (SCS)

### DIGITAL CONTROL

SCS is the revolutionary expert system created to manage the crimping operations for Manuli hose assemblies. It includes the integration of the Manuli Hydraulics fluid connectors assembling parameters, allowing easy machine set-up and automated quality control of the assembling process for improved production consistency and safety.

Large OEM hose assembly productions in particular require increasingly high quality standards from suppliers. They need proven and certified systems and processes with measurable and repeatable parameters.

### SCS is the answer.

SCS provides:

- Automated counting, mistake proofing, pressure control and quality control
- Automated crimp diameter set-up, according to hose selection and the required combination of fittings (insert and ferrule), with the Manuli crimp chart database embedded
- Pre-set calibration of the crimp diameter to compensate for instances of elastic rebound after the crimping operation
- Automatic measurement of the crimping diameter and crimping force, allowing for 100% quality checking and statistical data gathering
- Automated opening control to vary the opening process according to the requirements of the fitting geometry
- Possibility of progressive crimping (in steps rather than continuous) for use with tubing and thermoplastic hoses - Not suitable for rubber hose assemblies
- Possibility to program crimping sequences for elbows and straight fittings
- Assembly line identification (login / logout functions) to enhance traceability
- Maintenance alert for machine service
- Updates according to the latest Manuli crimping data for ongoing compliance with current requirements

Additionally, SCS creates and maintains a database of your assembling activities (including logs of recurrent and customised assemblies), recording the related control and custom parameters as well as personalised solutions.

SCS also provides an immediate alert for possible mistakes in production (eg: an incorrectly inserted fitting or an incomplete crimping operation). Mistakes are immediately detected and rejected by the system, minimising the possibility of the incorrect component being supplied to a customer.

SCS is available on all Manuli Hydraulics stand type crimp machines and on relevant new benchtop models.



# ACCESSORIES AND TOOLS

## ELECTRONIC PANEL

A modern flat panel with electronic buttons, which includes maintenance functions essential for keeping the machine in good condition.

### Maintenance functions include:

- **2 Counters:** 1 daily counter and 1 machine life counter
- **3 LED Indicator Lights:** 1 for daily maintenance, 1 for advanced maintenance and 1 for expert maintenance
- **Semi-automatic function:** The semi-automatic opening is ideal for serial assemblies as it can be adjusted specifically to allow the fitting to pass through the dies with minimal clearance, reducing the cycle time.



## NUMERICAL VERNIER

### AVAILABLE ON ALL MACHINES EXCEPT MHP 80

The ergonomic numerical vernier is the standard control system offered on Manuli machines.

This system is designed for machines used in repair workshops where assemblies are mostly composed of small batches. The crimping diameter is easily adjusted by a numerical vernier (2 colours highlighting mm and 0.1mm).

100 units on the dial change the crimping diameter by 1 mm. The adjustment of the crimping diameter can be controlled up to 1/100 mm. The counter is oriented toward the operator to provide high visibility. The unit also includes an end crimping light and a guard which is firmly fixed to the machine, protecting the vernier from damage.



*From MB 137 to MB 350*

# ACCESSORIES AND TOOLS

---

## ELECTRICAL FOOT SWITCH (EFS)

**AVAILABLE ON MACHINES FROM MB 137 PLUS TO GOLDENCRIMP 450 AND ALL STAND-TYPE MODELS**

The electrical foot switch allows the operator to use both hands during the crimping process, increasing ease of use and improving safety.



## MECHANICAL BACKSTOP (MBS)

**AVAILABLE ON MACHINES FROM MB 240 TO MB 350 AND STAND-TYPE MODELS**

The mechanical backstop allows quick positioning of the fittings in the crimp head. There is also an electronic version.

## ERGONOMIC TABLE (ET)

**AVAILABLE ON BENCHTOP CRIMPERS**

Specifically designed for the MB 240 and MB 350 crimpers, the ergonomic table provides a perfect working height, complete access around the machine and a minimal footprint. The front hook and the shelf also provide storage facilities.



# ACCESSORIES AND TOOLS

---

## ERGONOMIC QUICK CHANGE GUN

**AVAILABLE ON ALL MACHINES EXCEPT MHP 80**

This innovative quick change system is available on all electric crimping machines. The ergonomic quick change gun is ideal for maximising comfort and increasing productivity when changing die sets.

### **Fast, clean and ergonomic**

An ergonomic quick change gun provides the ability to change all of the dies simultaneously. The die sets are organised and stored in die pods on the machine panel.

### **Easy and safe**

The system is designed to be simple to use. Dies are changed in a static position to minimise the possibility of the die pins breaking.



# ACCESSORIES AND TOOLS

## HOW TO CHANGE THE DIE

### To insert the dies:

1. Choose the correct die set and take it out of the die rack.
2. Ensure the master dies are closed, then insert the die set into the head.
3. Release the die set into the head by pulling the trigger of the quick change gun.

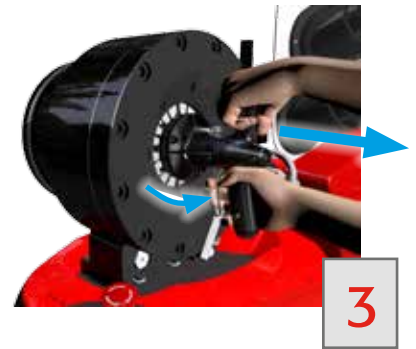
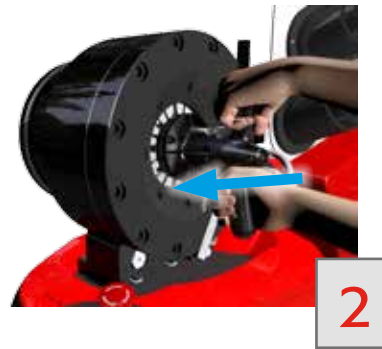

### To remove the dies:

4. Once the dies are closed, insert the quick change gun into the head until the die set is fixed to the magnets.
5. Pull the quick change gun out without pulling the trigger. The die set comes out of the head and is held by the magnets on the gun.
6. Place the die set back into the die rack.

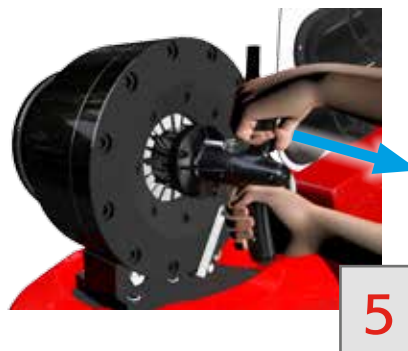



# APPENDICES





# LEGEND OF SYMBOLS



**Inside Diameter (I.D.)**



**Outside Diameter (O.D.)**



**Minimum Bend Radius**



**Reinforcement Outside Diameter (R.O.D.)**



**Maximum Working Pressure**



**Ferrule / Socket**



**Weight**



**Burst Pressure:** The minimum guaranteed burst pressure of the hose; Equivalent or superior to the minimum requirements of the reference specifications.

## Insert



- MF** MF2000<sup>®</sup> Multifit type
- IP** MF2000<sup>®</sup> Interlock Plus type
- SP** MF2000<sup>®</sup> Spiralfit type
- XL** MF2000<sup>®</sup> Xtralock type
- IS** MF2000<sup>®</sup> Interlock Super type
- BL** MF2000<sup>®</sup> Blastlock type
- PL** MF2000<sup>®</sup> Push-Lock type



**Working pressure:** The maximum pressure at which correct functioning of the quick coupling is assured. The working pressure is assured in both connected and disconnected states.



**Flow Rate:** The quantity of fluid which passes through a cross section of the quick coupling in a specified unit of time.



**Connection Effort:** The effort required to lock the male insert into the female.



**Oil Spillage:** The quantity of fluid lost from the coupling during the connection/disconnection process.



**Connection/Disconnection under pressure:** Ability to connect and disconnect with the quick coupling under pressure.

# GLOSSARY OF TERMS

---

**Continuous service:** Refers to the working temperature range

**Max. operating temperature (Intermittent service):** Peaks of temperature of short duration and total cumulative duration lower than 5% of the total service life.

**Recommended fluids:** Fluid types that the hose can convey with excellent / good chemical compatibility.

**Hose service life:** Cumulative duration of time in which the hose is under operative conditions.

# HOSE SIZE CONVERSION CHART

## HYDRAULICS

HOSE SIZE			
DN	dash	mm	inch
5	-03	4.7	$\frac{3}{16}$
6	-04	6.4	$\frac{1}{4}$
8	-05	7.9	$\frac{5}{16}$
10	-06	9.5	$\frac{3}{8}$
12	-08	12.7	$\frac{1}{2}$
16	-10	16.0	$\frac{5}{8}$
19	-12	19.0	$\frac{3}{4}$
25	-16	25.4	1
31	-20	31.8	$1\frac{1}{4}$
38	-24	38.1	$1\frac{1}{2}$
51	-32	50.8	2
60	-38	60.3	$2\frac{3}{8}$
63	-40	63.5	$2\frac{1}{2}$
76	-48	76.2	3
89	-56	88.9	$3\frac{1}{2}$
102	-64	101.6	4

# FLUID COMPATIBILITY CHART

**WARNING: Compatibility of hose and fittings with conveyed fluid is an essential factor in avoiding chemical reactions that may result in release of fluids or failure of the hose or connection. This chemical compatibility guide must not be used in conjunction with any other compatibility guides from previous or future catalogue editions, bulletins or publications. Incorrect use of these charts could result in personal injury or property damage.**

## HOSE SELECTION BY MEDIUM AND HOSE TYPE

This hose compatibility chart is a reference of Manuli Hydraulics hose compatibility with various fluid media. It is intended as a guide to chemical compatibility with inner tube materials and assembly lubricants applied internally to the hose. The Fluid Compatibility Chart lists the relative resistance of hose tube and fitting materials to more common:

- **hydraulic oils**
- **other diversified oils families (for hydrokinetic and lubrication applications)**
- **chemicals**

in three relative separated charts.

The ratings shown do not cover all possible variations of all factors, such as temperature, concentration, degradation or fluid contamination, etc. Testing under actual conditions is the best way to assure chemical compatibility for critical applications.

## PART 1: HYDROSTATIC OILS COMPATIBILITY CHART (ACTUAL HYDRAULIC SYSTEMS AND APPLICATIONS)

The specific recommendations regarding **hydraulic fluids** are based upon specific laboratory bench tests with fluids, performed according to ISO 1817 and internal methodology, integrated with field experiences and the advices of various polymers or fluid suppliers. **It must be stressed, however, that this information is offered only as a guide and is not a guarantee.** Final hose selection also depends upon pressure, fluid and ambient temperatures, concentration, duration of exposure and special requirements or variations, which may not be known by Manuli Hydraulics. Legal and other regulations must be followed with particular attention.

All the combined factors in working operations may impact on the service life of the hose assembly and must be carefully considered before releasing a hose for a specific application: the chemical compatibility with the service fluid is only one of the factors to be considered.

It is always recommended to test the specific fluid brand name with the requested hose, in order to verify chemical compatibility. Manuli Hydraulics constantly performs compatibility tests as service to market, progressively updating the compatibility chart.

**WARNING: Compatibility of hose and fittings with conveyed fluid is an essential factor in avoiding chemical reactions that may result in release of fluids or failure of the hose or connection. This chemical compatibility guide must not be used in conjunction with any other compatibility guides from previous or future catalogue editions, bulletins or publications. Incorrect use of these charts could result in death, personal injury or property damage.**

# FLUID COMPATIBILITY CHART

## PART 2: HYDROKINETIC APPLICATIONS AND LUBRICANT OILS COMPATIBILITY CHART (AUTOMATED TRANSMISSIONS AND VARIOUS LUBRICATION SYSTEMS)

This second part of the compatibility chart list a particular family of oils, not designed for standard hydraulics (hydrostatic applications), rather studied for many diversified applications such as lubrication for gear, compressors, turbines, diathermic oils for cooling or heat transmission, and ATF (Automatic Transmission Fluids) oils for the hydrokinetic (hydrodynamic) applications. These fluids are often very aggressive on traditional tube rubbers, more than hydraulic oils, due to the nature of the fluids and additives, aimed to give properties of long life duration and high temperature resistance; that's why their chemical compatibility with tube rubbers must be carefully checked before eventual use.

It is to be underlined that Manuli hoses are designed in principle for use with hydraulic oils only, and that diversified applications such as the ones with these categories of other oils, must be verified case by case with lab and/or field tests by users under their sole and exclusive responsibility and no liability whatsoever can be attributed to Manuli Hydraulics in that regard.

For more detailed information contact Manuli Hydraulics or visit [www.manuli-hydraulics.com](http://www.manuli-hydraulics.com)

## PART 3: BEHAVIOUR TO CHEMICALS (GUIDELINES FROM LITERATURE) FOR NON-HYDRAULIC APPLICATIONS

**WARNING: Manuli hoses are designed for hydraulics use and applications, they are not intended for industrial diversified applications with various chemicals.**

The recommendations regarding **generic chemicals** are mainly based on literature data in conjunction with polymers used for the tube compound. The field results of the fluid conveyed in the hose should be carefully tested and field validated by users.

No test on finished hose assemblies in combination with the mentioned chemicals has been normally performed.

**The possible good rating and on field performance of the hose with a chemical mentioned in the list does not mean in any case the release by Manuli Hydraulics of the product for that application or any guarantee. The possible validation for use is under the sole and exclusive responsibility of the end user and no liability whatsoever can be attributed to Manuli Hydraulics in that regard. In fact Manuli Hydraulics hoses are designed for hydraulics use and applications, they are not intended for industrial diversified applications with various chemicals.**

The outer cover of the hose is intended to protect the reinforcement layer(s) from mechanical influences (abrasion, weathering etc.); cover compounds are not designed to exhibit the same chemical resistance as the tube compounds. Manuli Hydraulics should be consulted about the compatibility of the cover, should the application involve the extended exposure or immersion in a liquid: **anyway the hydraulic hoses of the Manuli Hydraulics product range are not designed in general for immersion in the service fluid.**

**WARNING:** Compatibility of hose and fittings with conveyed fluid is an essential factor in avoiding chemical reactions that may result in release of fluids or failure of the hose or connection. This chemical compatibility guide must not be used in conjunction with any other compatibility guides from previous or future catalogue editions, bulletins or publications. Incorrect use of these charts could result in death, personal injury or property damage.

# FLUID COMPATIBILITY CHART

This type of special applications should be avoided or carefully studied with additional external protections for the hoses, selection of special hose types, e.g. with thermoplastic cover and validation on the specific application. The turbulence of the fluid, the high temperature and nature of the fluid as well as other elements may impact the properties or integrity of the hose cover material (the cover compound of the hose is designed to resist to oil drops and external agents, not immersion in the service fluid).

For more detailed information contact Manuli Hydraulics or visit [www.manuli-hydraulics.com](http://www.manuli-hydraulics.com)

**WARNING:** No tests on finished hose assemblies in combination with the mentioned chemicals has been normally performed. The possible good rating and on field performance of the hose with a chemical mentioned in the list, does not mean in any case the release by Manuli Hydraulics of the product for that application or any guarantee. The possible validation for use is under the sole and exclusive responsibility of the end user and no liability whatsoever can be attributed to Manuli Hydraulics in that regard. In fact Manuli Hydraulics hoses are designed for hydraulics use and applications, they are not intended for industrial diversified applications with various chemicals. No tests on finished hose assemblies in combination with the mentioned chemicals has been normally performed.

## LEGEND OF HOSE TYPES BY TUBE COMPOUNDS

Tube compound categories	Hose Types
NITRILE	std wire braid, textile braid & wire spiral hoses (Tractor, Harvester, Lyteflex, Firend, Goldenspir, Astro, Multitex, Pushfit, Cover, Spirtex/K, Rockmaster, Shieldmaster, Twinpower, GoldenISO, Goldenguard, Diamondspir, Xtraflow/4WS & 2WB, Pilot, Jackmaster)
CHLOROPRENE	Eternity/2, Nozone/2K, Goldenblast
CHLOROSULPHONATED POLYETHYLENE	Equator/1 (Blue & Black), Equator/2 (Blue & Black), Xtraflow/HT
CHLORINATED POLYETHELENE	Mastertex
POLYESTER	Hydroplast, Hydrotwin

**WARNING:** Compatibility of hose and fittings with conveyed fluid is an essential factor in avoiding chemical reactions that may result in release of fluids or failure of the hose or connection. This chemical compatibility guide must not be used in conjunction with any other compatibility guides from previous or future catalogue editions, bulletins or publications. Incorrect use of these charts could result in death, personal injury or property damage.

# FLUID COMPATIBILITY CHART

## HOW TO USE THE CHART

- Hydraulic fluids are listed in alphabetic order with the manufacturer brand name and ISO identification symbol (DIN when available), chemicals are listed alphabetically;
- Find the hose type and read the compatibility rating (see rating scale);
- Define the proper hose selection for the application by choosing the best rating.

## LEGEND OF RATINGS

**E = Excellent** - Small or negligible changes of compound properties: no problem for use. Service life can exceed the expectations.

**G = Good** - There are only minor changes of some compound properties. Service life is normally in line with state of the art (standard) expectations.

**C = Conditional** - Significant changes on some compound properties. Service life can be reduced; higher durability can be achieved with reduced severity of working conditions (temperature in particular) or with an upgraded hose selection. Whenever possible, a field validation under actual working conditions is recommended.

**X = Not recommended** - Unsuitable, severe effects on physical properties.

## REMARKS

- O-Rings used with couplings must also be considered for chemical compatibility with the fluid to be conveyed. This includes fittings containing internal O-Rings; for example Metric Female 24° Cone seat fittings, etc. Standard O-Ring of Manuli Hydraulics fittings are made of Nitrile rubber (NBR), highly chemically compatible with all hydraulic fluids. If you use special fluids or very high temperatures, different O-Ring materials should be used, contact Manuli Hydraulics for specific information. See Technical Manual for dimensions of O-Rings.
- Compatibility of hose fittings with conveyed fluids is an essential factor in avoiding chemical reactions that may result in release of fluids and failure of the connection with the potential of causing severe personal injury or property damage. Standard Manuli Hydraulics fittings are made of carbon steel with Hexavalent chromium free plating.

**WARNING:** Compatibility of hose and fittings with conveyed fluid is an essential factor in avoiding chemical reactions that may result in release of fluids or failure of the hose or connection. This chemical compatibility guide must not be used in conjunction with any other compatibility guides from previous or future catalogue editions, bulletins or publications. Incorrect use of these charts could result in death, personal injury or property damage.

# FLUID COMPATIBILITY CHART

## OILS CLASSIFICATION - ACCORDING TO ISO 6743-4

ISO 6743-4 is an important norm regarding "Lubricants, industrial oils and related products (class L)". The norm defines a very wide family of oils, used in many different sectors and applications.

The oils must be carefully understood and properly managed to avoid problems and possible mistakes. The Part 4 of the norm in particular regards the Hydraulic Oils (Family H), for hydrostatic and hydrokinematic applications, the other parts of the norm regard other fluids, of different nature or aimed to different applications than hydraulics.

Manuli Hydraulics hoses are designed and qualified for use with Hydraulic Oils (Family H of the ISO 6743-4), and the behaviour of the particular oil formulation has to be verified case by case.

The applications with oils of the families different than H must be checked carefully but in principle Manuli Hydraulics hoses are not designed for use with them.

Here below the classification of oils by ISO 6743 spec.

Part 1: Family A (Total Loss systems)

Part 2: Family F (Spindle bearings, bearings and associated clutches)

Part 3A: Family D (Compressors)

Part 3B: Family D (Gas and refrigeration compressors)

### **Part 4: Family H (Hydraulic Systems)**

Part 5: Family T (Turbines)

Part 6: Family C (Gears)

Part 7: Family M (Metalworking)

Part 8: Family R (Temporary protection against corrosion)

Part 9: Family X (Greases)

Part 10: Family Y (Miscellaneous)

Part 11: Family P (Pneumatic tools)

Part 12: Family Q (Heat Transfer Fluids)

Part 13: Family G (Slideways)

Part 14: Family U (Heat treatment)

Part 15: Family E (Internal combustion engines)

**WARNING:** Compatibility of hose and fittings with conveyed fluid is an essential factor in avoiding chemical reactions that may result in release of fluids or failure of the hose or connection. This chemical compatibility guide must not be used in conjunction with any other compatibility guides from previous or future catalogue editions, bulletins or publications. Incorrect use of these charts could result in death, personal injury or property damage.



# FLUID COMPATIBILITY CHART

The Family H in particular, object of use with Manuli Hydraulics hoses is composed by the following families of oils, identified by ISO dedicated symbols, used also in the compatibility chart.

General application	Particular application	More specific applications	Composition and properties	Symbol ISO-L
<b>HYDRAULIC SYSTEMS</b>	<b>HYDROSTATIC APPLICATIONS</b>	(std hydraulic applications)	Non-inhibited refined mineral oils	HH
			Refined mineral oils with improved anti-rust and anti-oxidation properties	HL
			Oils of HL type with improved anti-wear properties	HM
			Oils of HL type with improved viscosity/temperature properties	HR
			Oils of HM type with improved viscosity/temperature properties	HV
			Synthetic fluids with no specific fire resistant properties	HS
		Applications where environmentally acceptable fluids are requested	Triglycerides	HETG
			Polyglycols	HEPG
			Synthetic esters	HEES
			Polyalpaoelefin and related hydrocarbon products	HEPR
		Hydraulic slide-way systems	Oils of HM tyoe with anti-stick/slip properties	HG
		Applications where fire resistant fluids are required	Oils in water emulsion	HFAE
			Chemical solution in water	HFAS
			Water in oil emulsion	HFB
			Water polymer souldtions	HFC
			Synthetic fluids containing no water and consisting of phosphate esters	HFDR
			Synthetic fluids containing no water and of other composition	HFDU
		<b>HYDROKINETIC APPLICATIONS</b>	Automatic transmissions	(ATF oils)
	Couplers and converters		HN	

- XXXX
 Generally good compatibility with hoses, anyway the behaviour of the particular oil formation to be verified case by case
- HA & HN
 ATF oils, chemical compatibility with hoses to be carefully verified case by case upon request and application
- HFAS & HFDR
 No compatibility with Manuli Hydraulics hoses. Dedicated hoses are requested

**WARNING:** Compatibility of hose and fittings with conveyed fluid is an essential factor in avoiding chemical reactions that may result in release of fluids or failure of the hose or connection. This chemical compatibility guide must not be used in conjunction with any other compatibility guides from previous or future catalogue editions, bulletins or publications. Incorrect use of these charts could result in death, personal injury or property damage.

# FLUID COMPATIBILITY CHART

## PART 1: HYDROSTATIC APPLICATION OILS COMPATIBILITY CHART

(ACTUAL HYDRAULIC SYSTEMS AND APPLICATIONS)

HYDRAULIC FLUID	Type		Wire Spiral	Wire Braid				Textile Braid	TPE Textile Braid
	ISO 6743-4	DIN 51524	DIAMONDSPIR SHIELDMASTER ROCKMASTER GOLDENISO/XF FORESTMASTER	ETERNITY/2 NOZONE 2K	TRACTOR SHIELDMASTER ROCKMASTER HARVESTER/17 GOLDENISO LYTEFLEX COVER	GOLDENISO/LL	EQUATOR	ASTRO SPIRTEX/K MULTITEX PUSH FIT	HYDROPLAST HYDROTWIN
ACT Ecosafe FR 46	HFDU	-	E	E	C	-	C	G	-
ACT FR WG 200 D	HFC	-	E	X	E	-	X	E	-
ADDINOL Ökosynth Super HEES 46	HEES	-	G	C	G	-	C	G	-
ADDINOL Ökosynth Super HEES 46 S	HEES	-	G	C	G	G	C	G	-
AGIP Arnica 46	HV	HVLP	E	G	G	G	E	G	-
AGIP Arnica Extra Plus	HEES	HVLP	G	G	G	G	C	G	E
AGIP Arnica Plus	HEES	HVLP	E	E	G	G	C	E	E
AGIP Arnica S46	HFDU	-	E	E	G	G	C	E	E
AGIP Oso 32	HM	HLP	E	E	G	-	E	E	G
AGIP Oso 46 S	HM	HLP	E	G	G	G	G	G	G
AGIP Oso D 46	HM	HLPD	G	G	C	E	G	G	-
AGROL Mendo 46 G4	HEES	-	-	C	-	-	C	-	-
AKZO Fyrquel	HFDR	-	X	X	X	X	-	X	-
AMBRA Hitech 46	HL	HLP	E	E	G	-	G	E	G
ANDEROL 8768 (PAO)	HEPR	-	G	G	C	G	C	G	-
API HS 46	HV	HVLP	E	G	G	-	E	-	-
ARAL Vitam EHF 46	HEES	-	E	E	G	-	G	G	G
ARAL Vitam GF 68	HL	HLP	E	E	E	-	E	E	E
AVIA Avilub HLP 46	HM	HLP	G	G	G	G	E	G	-
AVIA Avilub SF 568	HM	HLP	-	-	-	-	G	-	-
AVIA Biofluid BP 32	HEES	-	G	C	G	E	X	G	-

**WARNING:** Compatibility of hose and fittings with conveyed fluid is an essential factor in avoiding chemical reactions that may result in release of fluids or failure of the hose or connection. This chemical compatibility guide must not be used in conjunction with any other compatibility guides from previous or future catalogue editions, bulletins or publications. Incorrect use of these charts could result in death, personal injury or property damage.

# FLUID COMPATIBILITY CHART

HYDRAULIC FLUID	Type		Wire Spiral	Wire Braid				Textile Braid	TPE Textile Braid
	ISO 6743-4	DIN 51524	DIAMONDSPIR SHIELDMASTER ROCKMASTER GOLDENISO/XF FORESTMASTER	ETERNITY/2 NOZONE 2K	TRACTOR SHIELDMASTER ROCKMASTER HARVESTER/17 GOLDENISO LYTEFLEX COVER	GOLDENISO/LL	EQUATOR	ASTRO SPIRITEX/K MULTITEX PUSH FIT	HYDROPLAST HYDROTWIN
AVIA Fluid RSL 32	HM	HLP	E	G	G	-	-	-	-
AVIA Fluid RSL 68	HM	HLP	G	G	G	G	E	G	-
AVIA HVI 46	HV	HVLP	G	G	G	-	E	G	-
AVIA Syntofluid F 46	HEES	-	E	G	E	-	G	G	E
AVIA Syntofluid N 32	HEES	-	G	G	E	G	G	E	G
AVIA Syntofluid N 46	HEES	-	E	E	G	-	G	E	G
AVIA Syntofluid PE B 30 (PAO)	HEPR	-	E	G	G	G	G	G	G
AVIA Syntofluid PE B 50 (PAO)	HEPR	-	E	E	G	G	G	G	-
BECHEM Hydrostar PM 46	HH	-	E	E	G	-	G	E	-
BINOL Hydrap 46	HETG	-	E	E	G	G	-	G	-
BP A 0629L/028	HS	-	G	C	G	G	E	G	G
BP Bartran HV	HV	HVLP	E	G	G	G	E	G	-
BP Biohyd SE-S 46	HEES	-	G	G	E	-	C	E	-
BP Energol HLP 46	HL	HLP	G	G	G	-	-	-	-
BREMER Rivolta SBH 23	HEES	-	E	G	E	G	G	G	E
CALTEX Rando DSZ 46	HV	HVLP	G	G	C	-	G	C	-
CALTEX Rando HD	HM	HLP	E	G	G	G	G	G	G
CALTEX Rando HD LVZ 46	HV	HVLP	G	G	C	G	G	C	-
CASTROL Aero HF 585 B (MIL 56006H)	HH	HL	E	C	G	-	C	E	C
CASTROL Anvol SWX 68 (POE based)	HFDU	-	E	C	E	-	C	G	-
CASTROL Biobar VG 68	HEES	-	E	C	E	E	X	G	-
CASTROL Biotech Alpin 22	HETG	-	E	E	E	-	C	E	-
CASTROL Brayco 717 (MIL 17111c)	HS	-	G	C	G	-	C	G	G
CASTROL Brayco Micronic 882	HH	HL	G	G	G	G	G	G	G

**WARNING:** Compatibility of hose and fittings with conveyed fluid is an essential factor in avoiding chemical reactions that may result in release of fluids or failure of the hose or connection. This chemical compatibility guide must not be used in conjunction with any other compatibility guides from previous or future catalogue editions, bulletins or publications. Incorrect use of these charts could result in death, personal injury or property damage.

# FLUID COMPATIBILITY CHART

HYDRAULIC FLUID	Type		Wire Spiral	Wire Braid				Textile Braid	TPE Textile Braid
	ISO 6743-4	DIN 51524	DIAMONDSPIR SHIELDMASTER ROCKMASTER GOLDENISO/XF FORESTMASTER	ETERNITY/2 NOZONE 2K	TRACTOR SHIELDMASTER ROCKMASTER HARVESTER/17 GOLDENISO LYTEFLEX COVER	GOLDENISO/LL	EQUATOR	ASTRO SPIRITEX/K MULTITEX PUSH FIT	HYDROPLAST HYDROTWIN
CASTROL Carelube HTG	HETG	-	E	C	E	-	C	E	G
CASTROL Carelube HY 46	HEES	-	G	G	G	-	C	G	G
CASTROL Hyspin HDH 7000	HM	-	E	G	G	-	E	E	-
CASTROL Hyspin ZZ32	HM	HLP	G	G	G	G	E	G	G
CASTROL Lift oil	HH	HL	G	G	G	G	G	G	G
CASTROL Product L 320	HFDU	-	E	G	G	-	X	G	
CASTROL Product L 571	HH	HL	E	G	G	G	X	G	-
CENEX Indol Premium AW 4646	HM	HLP	G	E	G	G	-	G	-
CEPSA Hidraulico HM 46	HM	HLP	E	E	G	-	E	G	E
CHEVRON ETL 10328	HV	HVLP	G	E	C	G	G	G	-
CHEVRON Extra Hyd oil VG 46	HM	-	G	G	G	G	C	-	-
CHEVRON Hydraulic AW 46	HM	HLP	E	G	G	-	E	G	-
CHEVRON Machine oil AW 220	HV	HLP	G	G	G	-	G	G	G
CHEVRON Machine oil AW ISO 46	HV	HLP	G	G	G	-	G	G	G
CHEVRON Rando HD 68	HM	HLP	G	G	G	G	G	G	-
CHEVRON Rycon MV	HM	-	E	G	G	-	G	G	-
COAST OIL A/W 68	HM	-	G	G	C	-	G	-	-
CONDAT D 46	HFDU	-	E	C	G	-	C	G	-
CONOCO Ecoterra	HM	HLP	G	G	-	G	-	-	-
DEA Econa E 46	HEES	-	G	C	E	G	C	E	E
DOT 3	HPG	-	-	-	X	-	X	X	G
DOT 4	HPG	-	-	-	X	-	X	X	G
ELAN Hydraulic 46	HV	HVLP	E	G	G	-	E	G	G
ESSO Hidraulikoel HE 46	HEES	-	E	E	E	-	G	E	E
ESSO Nuto H46	HM	HLP	G	G	G	-	E	G	E

**WARNING:** Compatibility of hose and fittings with conveyed fluid is an essential factor in avoiding chemical reactions that may result in release of fluids or failure of the hose or connection. This chemical compatibility guide must not be used in conjunction with any other compatibility guides from previous or future catalogue editions, bulletins or publications. Incorrect use of these charts could result in death, personal injury or property damage.

# FLUID COMPATIBILITY CHART

HYDRAULIC FLUID	Type		Wire Spiral	Wire Braid				Textile Braid	TPE Textile Braid
	ISO 6743-4	DIN 51524	DIAMONDSPIR SHIELDMASTER ROCKMASTER GOLDENISO/XF FORESTMASTER	ETERNITY/2 NOZONE 2K	TRACTOR SHIELDMASTER ROCKMASTER HARVESTER/17 GOLDENISO LYTEFLEX COVER	GOLDENISO/LL	EQUATOR	ASTRO SPIRITEX/K MULTITEX PUSH FIT	HYDROPLAST HYDROTWIN
EXXON HUMBLE H 46	HM	HLP	E	G	G	-	E	G	-
EXXON RL 002775B	HM	-	G	G	C	G	C	-	-
EXXON Univis N46	HV	HVLP	E	G	G	G	E	G	-
FINKE Aviaticon HY HE	HEES	-	G	G	E	-	-	E	G
FOLTZERMSPRINGOLI Hydra 46	HH	-	G	G	G	G	E	G	-
FRAGOL HE 46	HEES	-	E	C	G	-	C	G	E
FUCHS Eco Hyd 46S NWG	HEES	-	G	C	G	-	X	G	-
FUCHS OM 13	HH	HL	G	G	G	-	G	E	E
FUCHS OM 65	HH	HL	G	G	G	-	-	G	G
FUCHS Plantohyd S 46	HEES	-	E	C	E	-	C	E	E
FUCHS Plantohyd N 46	HETG	-	G	C	E	G	C	E	E
FUCHS Plantohyd SUPER S46	HEES	-	G	X	E	G	X	-	-
FUCHS Plantosyn 3268 Eco	HEES	-	G	C	E	-	G	E	G
FUCHS Plantosyn 46 HVI	HEES	-	E	C	G	-	C	G	G
FUCHS RENOLIN B 46 HVI	HV	HVLP	E	G	G	-	E	G	G
FUCHS Renolin B15 VG46	HM	HVLP'	G	G	G	-	-	-	-
FUCHS Renolin D15 VG 46	HM	HLPD	E	G	G	G	-	G	-
FUCHS Renolin MR 520	HV	HVLPD	G	G	G	-	G	E	E
GULF Armony AW 46	HM	HLP	E	E	G	-	E	G	E
HOUGHTON Cosmolubric HF 130 (POE based)	HFDU	-	G	G	G	-	C	G	-
HOUGHTON Hydravis BC 84005 (60°C)	HFA	-	E	G	E	-	C	E	E
HOUGHTON Isocore E 68 plus	HFC	-	E	G	E	-	C	G	-
HOUGHTON Safe 620	HFC	-	G	G	G	-	X	-	-
HOUGHTON Safe OX 40	HFC	-	E	G	E	-	C	E	E
HOUGHTON Vital fluid L46AL	HFDU	-	G	G	E	-	C	-	-

**WARNING:** Compatibility of hose and fittings with conveyed fluid is an essential factor in avoiding chemical reactions that may result in release of fluids or failure of the hose or connection. This chemical compatibility guide must not be used in conjunction with any other compatibility guides from previous or future catalogue editions, bulletins or publications. Incorrect use of these charts could result in death, personal injury or property damage.

# FLUID COMPATIBILITY CHART

HYDRAULIC FLUID	Type		Wire Spiral	Wire Braid				Textile Braid	TPE Textile Braid
	ISO 6743-4	DIN 51524	DIAMONDSPIR SHIELDMASTER ROCKMASTER GOLDENISO/XF FORESTMASTER	ETERNITY/2 NOZONE 2K	TRACTOR SHIELDMASTER ROCKMASTER HARVESTER/17 GOLDENISO LYTEFLEX COVER	GOLDENISO/LL	EQUATOR	ASTRO SPIRTEX/K MULTITEX PUSH FIT	HYDROPLAST HYDROTWIN
HOUGHTON-Safe 273 CTF	HFC	-	E	C	E	-	X	E	E
IDEMITSU Daphne 46	HM	HLP	G	G	G	G	G	G	-
IGOL Matic ZNS 46	HV	-	E	G	G	-	E	-	-
IGOL Ticma Fluid	HV	-	E	G	G	-	E	G	-
IGOL Ticma Fluid BIO 46	HEES	-	G	G	G	-	C	G	-
INGERSOLL RAND SSR Ultracoolant (Polyglycole comp. coolant)	HEPG	-	G	G	G	-	G	G	-
INGERSOLL RAND Techtrol Gold(Polyglycole comp. coolant)	HEPG	-	G	C	G	-	G	G	-
IRVING hydraulic 46	HM	HLP	G	G	G	-	E	G	-
JIANGSU GAOKE L-HM32	HM	HLP	-	-	G	-	E	-	-
JOHN DEERE Bio Guard II	HETG	-	E	E	E	-	E	G	G
KLUBER Hysyn FG46	HS	-	G	G	C	-	G	C	-
KLUBER KluberBIO LR 9 68	HEES	-	E	C	G	G	X	G	-
KLUBERFOOD 4 NH1 46	HM	HLP	G	C	C	-	C	C	-
KOMATSU Genuine Bio 46 G4	HEES	-	E	G	G	-	G	G	E
KOMATSU KPO 10 Powertrain TO 10	HH	-	E	E	G	-	G	G	E
KUNLUN LHM 46	HM	HLP	E	G	G	G	E	G	G
LIEBHERR Hyd Basic 68	HM	HLPD	E	G	G	-	-	-	-
LIEBHERR Hydraulic HVI	HV	HVLPD	E	G	G	-	-	G	-
LIEBHERR Hydraulic Plus	HEPR	HVLPD	G	G	C	G	-	-	-
LIEBHERR Hydraulic Plus Arctic	HEPR	HVLPD	E	E	G	-	-	-	-
LUKOIL Geyser ST	HM	-	E	G	G	G	E	G	G
LUKOIL Geyser ZF	HM	HLP	G	G	G	G	E	G	G
MACDERMID Oceanic BTC 181	HS	-	E	G	G	G	-	G	G
MLC MetLube HFR 220	HFDU	-	G	G	G	G	E	C	-
MICRO QUIMICA Microcorte 530	HFB	-	C	X	C	-	X	C	-

**WARNING:** Compatibility of hose and fittings with conveyed fluid is an essential factor in avoiding chemical reactions that may result in release of fluids or failure of the hose or connection. This chemical compatibility guide must not be used in conjunction with any other compatibility guides from previous or future catalogue editions, bulletins or publications. Incorrect use of these charts could result in death, personal injury or property damage.

# FLUID COMPATIBILITY CHART

HYDRAULIC FLUID	Type		Wire Spiral	Wire Braid				Textile Braid	TPE Textile Braid
	ISO 6743-4	DIN 51524	DIAMONDSPIR SHIELDMASTER ROCKMASTER GOLDENISO/XF FORESTMASTER	ETERNITY/2 NOZONE 2K	TRACTOR SHIELDMASTER ROCKMASTER HARVESTER/17 GOLDENISO LYTEFLEX COVER	GOLDENISO/LL	EQUATOR	ASTRO SPIRITEX/K MULTITEX PUSH FIT	HYDROPLAST HYDROTWIN
MILLERS Millmax 22	HM	-	E	G	G	G	G	G	-
MILLERS Millfood 32	HS	-	G	G	G	-	E	G	E
MOBIL Aero HF 46 (MIL 5606H)	HH	HL	E	G	G	-	C	G	-
MOBIL DTE 10 Excel 46	HV	HVLP	G	E	G	G	C	G	-
MOBIL DTE 10 Excel 68	HV	HVLP	G	G	C	G	C	-	-
MOBIL DTE 13	HV	HVLP	E	G	G	-	E	G	-
MOBIL DTE 24	HV	HVLP	G	G	G	-	E	G	-
MOBIL DTE 25	HV	HVLP	E	G	G	-	E	G	E
MOBIL DTE 26	HV	HVLP	G	G	G	-	E	C	E
MOBIL DTE EXCEL 46	HM	HLP	E	E	G	G	E	G	G
MOBIL DTE EXCEL 68	HM	HLP	G	-	-	-	E	-	-
MOBIL DTE FM 32	HM	-	E	G	G	-	G	G	-
MOBIL EAL 224 H	HETG	-	G	G	E	G	X	E	G
MOBIL Hydrofluid HFDU	HFDU	-	E	E	E	E	G	E	E
MOBIL SHC 524	HM	-	E	G	C	G	E	-	-
MORRIS Triad 32	HM	-	-	G	G	G	G	-	-
MOTOREX Alpine Corex Polar S370	HV	HVLP	G	G	C	G	-	G	-
MOTOREX Corex HW	HV	HVLP	E	G	G	E	E	E	G
MOTUL Shock oil VI 400	HEES	-	G	C	G	-	X	G	-
NALCO Varidos FSK 40%	HFB	-	E	G	E	E	C	E	-
NESTE BIO Hydraulik LONGLIFE 46	HEES	-	G	C	G	-	C	G	-
NESTE BIO Hydraulik SE 46	HEES	-	G	C	G	G	C	G	-
NESTE Hydraulik 32 SUPER	HV	HVLP	E	G	G	G	E	-	-
NESTE Hydraulik 46 SUPER	HV	HVLP	E	G	G	G	E	-	-
NESTE Hydraulik 68 Super	HV	HVLP	G	E	G	G	E	G	E

**WARNING:** Compatibility of hose and fittings with conveyed fluid is an essential factor in avoiding chemical reactions that may result in release of fluids or failure of the hose or connection. This chemical compatibility guide must not be used in conjunction with any other compatibility guides from previous or future catalogue editions, bulletins or publications. Incorrect use of these charts could result in death, personal injury or property damage.

# FLUID COMPATIBILITY CHART

HYDRAULIC FLUID	Type		Wire Spiral	Wire Braid				Textile Braid	TPE Textile Braid
	ISO 6743-4	DIN 51524	DIAMONDSPIR SHIELDMASTER ROCKMASTER GOLDENISO/XF FORESTMASTER	ETERNITY/2 NOZONE 2K	TRACTOR SHIELDMASTER ROCKMASTER HARVESTER/17 GOLDENISO LYTEFLEX COVER	GOLDENISO/LL	EQUATOR	ASTRO SPIRTEX/K MULTITEX PUSH FIT	HYDROPLAST HYDROTWIN
NEW PROCESS AG NP Hyd oil PC HV1 46	HV	HVLP	-	C	C	G	G	-	-
NOALOIL Idro 32	HV	HLP	E	G	G	-	E	G	G
NYCO Hydraulic Oil FH 3 (MIL H 46170 C-1)	HH	HL	E	G	G	G	E	G	-
NYCO Hydraulic Oil FH 51 (MIL 5606H)	HH	HL	E	G	G	G	C	G	-
NYCO Hydraulic Oil FH 6 (MIL 6083H)	HH	HL	G	G	E	-	C	E	C
OEST Dopp-Synth 60	HLP	-	G	X	G	G	X	G	-
OEST Dopp-Synth 70	HLP	-	G	X	G	-	X	G	-
OMD 90	HH	HL	G	G	G	-	-	G	G
OMV Biohyd MS 46 (100°C)	HEES	-	G	G	G	G	-	G	G
OMV HLP AL 46	HL	HLP	E	G	C	-	E	C	-
OMV HLP M32	HV	HVLP	G	G	G	E	-	G	-
OMV Hyd HLP M15	HV	HVLP	E	C	G	G	-	G	-
PANOLIN EP Gear Synth 30 VDT	HEES	-	G	X	G	G	X	G	G
PANOLIN GRO Synth 46	HEES	-	G	C	G	G	C	-	E
PANOLIN HLP Synth 15	HEES	-	G	X	X	-	X	G	-
PANOLIN HLP Synth 46	HEES	-	E	C	G	G	X	G	G
PANOLIN HLP Synth E 46	HEES	-	E	C	G	G	X	G	E
PANOLIN HLP Uni 46	HV	HVLP	E	G	G	-	G	G	-
PANOLIN Orcon Hyd 46	HV	HVLP	G	G	C	G	G	G	-
PANOLIN Trafosynth 2	HEES	-	G	X	G	-	X	G	-
PENTOSIN CHF 11 S (Power Steering)	HV	-	E	G	G	G	E	G	-
PETRO CANADA Hydrex AW 46	HM	HLP	E	G	C	G	C	C	-
PETRO CANADA Hydrex MV 60	HV	HVLP	E	E	G	G	C	G	-
PETROFER Ultra Safe 620	HFC	-	G	C	E	-	X	E	-
PFINDER Aapresol	HH	-	G	G	G	-	E	G	E

**WARNING:** Compatibility of hose and fittings with conveyed fluid is an essential factor in avoiding chemical reactions that may result in release of fluids or failure of the hose or connection. This chemical compatibility guide must not be used in conjunction with any other compatibility guides from previous or future catalogue editions, bulletins or publications. Incorrect use of these charts could result in death, personal injury or property damage.



# FLUID COMPATIBILITY CHART

HYDRAULIC FLUID	Type		Wire Spiral	Wire Braid				Textile Braid	TPE Textile Braid
	ISO 6743-4	DIN 51524	DIAMONDSPIR SHIELDMASTER ROCKMASTER GOLDENISO/XF FORESTMASTER	ETERNITY/2 NOZONE 2K	TRACTOR SHIELDMASTER ROCKMASTER HARVESTER/17 GOLDENISO LYTEFLEX COVER	GOLDENISO/LL	EQUATOR	ASTRO SPIRITEX/K MULTITEX PUSH FIT	HYDROPLAST HYDROTWIN
Q8 Handel 68	HV	HVLP	G	G	G	-	E	G	E
Q8 Haydn	HM	HLP	E	G	G	G	E	G	-
Q8 Heller 46	HV	HVLP	E	G	G	-	E	G	-
Q8 Hogarth 46	HV	HVLP	G	G	C	G	C	G	-
Q8 Holbein	HEES	-	E	G	G	-	G	G	-
Q8 Hummel 46	HM	HLP	E	E	G	-	G	-	-
QUAKER Greensave N 40	HETG	-	G	G	G	-	C	G	G
QUAKER Quintolubric 888	HFDU	-	G	G	G	G	C	G	-
QUAKER Quintolubric 888-46	HFDU	-	G	C	G	G	C	-	-
QUAKER Quintolubric 888-68	HFDU	-	G	C	G	-	C	-	-
QUAKER Quintolubric N 822-300	HFDU	-	G	C	G	-	-	G	-
QUAKER Quintolubric N852	HFDU	-	G	X	G	G	X	E	-
RAUTIO ERGO MIX	HH	-	E	G	G	-	E	-	-
REPSOL Telex 32	HM	HLP	G	E	G	E	G	G	G
ROLOIL Estin S46	HFDU	-	G	C	G	G	X	G	-
SAFETY KLEEN Performance PLUS AW 32	HM	-	G	G	C	G	G	-	-
SHAEFFER 112 HTC	HM	HLP	G	G	G	-	E	-	-
SHAEFFER 112 NZ HTC 32	HM	HLPD	G	G	C	G	G	C	-
SHAEFFER 254 SUPREME ISO 32 TH 220	HM	HLP	G	C	C	G	G	C	-
SHAEFFER 275 S Dilux Supreme MEHF HYD	HV	HLPD	G	E	G	E	E	C	-
SHELL Aeroshell Fluid 41 (MIL 5606H)	HH	HL	E	G	G	-	C	G	-
SHELL Aeroshell Fluid 602 (MIL-PRF 87252C)	HEPR	-	E	E	G	-	E	G	G
SHELL Astron HL 46	HH	-	E	E	G	G	G	-	-
SHELL Donax TA (Torque conv. Allison C-3)	HM	-	-	-	G	G	G	-	-
SHELL Hydraulic oil PW 46	HV	HVLP	E	G	G	E	G	G	G

**WARNING:** Compatibility of hose and fittings with conveyed fluid is an essential factor in avoiding chemical reactions that may result in release of fluids or failure of the hose or connection. This chemical compatibility guide must not be used in conjunction with any other compatibility guides from previous or future catalogue editions, bulletins or publications. Incorrect use of these charts could result in death, personal injury or property damage.

# FLUID COMPATIBILITY CHART

HYDRAULIC FLUID	Type		Wire Spiral	Wire Braid				Textile Braid	TPE Textile Braid
	ISO 6743-4	DIN 51524	DIAMONDSPIR SHIELDMASTER ROCKMASTER GOLDENISO/XF FORESTMASTER	ETERNITY/2 NOZONE 2K	TRACTOR SHIELDMASTER ROCKMASTER HARVESTER/17 GOLDENISO LYTEFLEX COVER	GOLDENISO/LL	EQUATOR	ASTRO SPIRITEX/K MULTITEX PUSH FIT	HYDROPLAST HYDROTWIN
SHELL Irus Fluid DU-NA 46	HFDU	-	E	E	E	-	G	G	-
SHELL Irus Fluid DU-NA 68	HFDU	-	E	E	E	-	G	G	-
SHELL Morlina 220	HL	HLP	G	G	G	G	E	C	G
SHELL Morlina S2 BL10	HL	HLP	G	C	G	G	X	G	G
SHELL Morlina S2 BL5	HL	HLP	C	X	G	C	X	G	G
SHELL Naturelle HF-E15	HEES	-	E	C	G	-	X	G	G
SHELL Naturelle HF-E46	HEES	-	E	C	G	-	X	E	G
SHELL Targon AL plus	HH	-	E	C	E	-	C	G	-
SHELL Tellus Arctic 32	HH	HL	G	G	G	G	G	G	E
SHELL Tellus S1 M 46 (ex Tellus H 46)	HM	-	G	G	G	G	-	-	-
SHELL Tellus S2 M 100 (ex Tellus 100)	HM	-	E	G	G	G	G	G	G
SHELL Tellus S2 M 46 (ex Tellus 46)	HM	HLP	E	G	G	G	E	G	E
SHELL Tellus S2 M 68 (ex Tellus 68)	HM	HLP	E	G	G	G	E	G	-
SHELL Tellus S2 MA 46	HM	HVLP	E	G	G	E	G	G	-
SHELL Tellus S2 V 32 (ex Tellus T 32)	HV	HVLP	E	G	G	E	E	G	G
SHELL Tellus S2 V 46 (ex Tellus T 46)	HV	HVLP	E	G	G	E	E	G	G
SHELL Tellus S2 V 68 (ex Tellus T 68)	HV	HVLP	E	G	G	-	E	G	-
SHELL Tellus S3 V 32 (ex Tellus STX)	HV	HVLP	E	G	C	G	E	G	G
SHELL Tellus S3 V 46 (ex Tellus STX)	HV	HVLP	E	G	C	G	E	G	G
SHELL Tellus S46	HM	HLP	E	G	G	-	E	G	E
SHELL Tellus S4ME 46 (ex Tellus EE 46)	HM	HLP	E	C	-	-	-	-	-
SHELL Tellus TX 68	HV	-	G	C	G	E	G	G	-
SHENYANG TeLi Aeronautic Hydraulic Oil 10#	HV	-	G	-	G	G	C	-	-
SINOPEC L HM 32	HM	HLP	E	-	G	-	G	-	-
SMALLMAN Crownpress 46	HH	-	G	G	G	-	E	G	E

**WARNING:** Compatibility of hose and fittings with conveyed fluid is an essential factor in avoiding chemical reactions that may result in release of fluids or failure of the hose or connection. This chemical compatibility guide must not be used in conjunction with any other compatibility guides from previous or future catalogue editions, bulletins or publications. Incorrect use of these charts could result in death, personal injury or property damage.

# FLUID COMPATIBILITY CHART

HYDRAULIC FLUID	Type		Wire Spiral	Wire Braid				Textile Braid	TPE Textile Braid
	ISO 6743-4	DIN 51524	DIAMONDSPIR SHIELDMASTER ROCKMASTER GOLDENISO/XF FORESTMASTER	ETERNITY/2 NOZONE 2K	TRACTOR SHIELDMASTER ROCKMASTER HARVESTER/17 GOLDENISO LYTEFLEX COVER	GOLDENISO/LL	EQUATOR	ASTRO SPIRITEX/K MULTITEX PUSH FIT	HYDROPLAST HYDROTWIN
SOLUTIA Skydroll 500	HFDR	-	X	X	X	-	X	X	X
STATOIL Hydraway Extreme 46	HM	HLP	E	G	G	E	E	-	-
STATOIL Hydraway HVXA 15	HV	HVLP	G	-	G	G	-	G	-
STATOIL Hydrocor CC44	HFC	-	E	G	E	-	C	G	-
STUART Isocore E 68 Plus	HPG	-	E	G	G	G	C	E	-
SUNOCO Sunvis 746	HM	HLP	E	G	G	G	E	C	G
SUNOCO Sunvis 846	HV	HVLP	E	G	G	G	G	G	G
SUNOCO Sunvis 846 WR	HV	HLP	E	G	G	G	G	G	G
TAMOIL Green Hydro Safety 46	HETG	-	E	E	G	-	-	E	G
TEBOIL Hydraulic arctic	HH	-	G	G	E	G	G	E	E
TEBOIL Eco 46	HEES	-	E	E	G	G	C	G	G
TERRESOLVE Greenscare 46	HETG	-	G	G	G	G	G	G	-
TEXACO Biostar Hydraulic 32	HETG	-	E	C	E	G	C	E	-
TEXACO Hydra 46	HEES	-	E	C	G	-	C	G	G
TEXACO Rando HD 46	HM	HLP	E	G	C	-	G	C	G
TEXACO Rando HD LVZ 46	HV	HVLP	G	G	C	G	G	C	-
TEXACO Rando HD VZ 46	HV	HVLP	G	G	G	G	C	G	G
TEXACO Rando HD VZ 68	HV	HVLP	G	G	G	C	G	G	-
TEXACO Rando HD Z 46	HV	HVLP	E	G	G	G	G	G	-
TEXACO Synstar HT 68	HFDU	-	G	G	E	-	C	E	G
TOTAL Azolla HZS 46	HM	HLP	E	G	G	-	E	-	-
TOTAL Azolla ZS 46	HM	HLP	E	G	G	-	E	G	G
TOTAL Biohydran SE 46	HEES	-	G	C	G	-	X	E	G
TOTAL Equivis ZS 46	HV	HVLP	G	G	G	-	-	C	-
TOTAL Hydransafe HFDU 46	HFDU	-	E	-	G	-	-	-	-

**WARNING:** Compatibility of hose and fittings with conveyed fluid is an essential factor in avoiding chemical reactions that may result in release of fluids or failure of the hose or connection. This chemical compatibility guide must not be used in conjunction with any other compatibility guides from previous or future catalogue editions, bulletins or publications. Incorrect use of these charts could result in death, personal injury or property damage.

# FLUID COMPATIBILITY CHART

HYDRAULIC FLUID	Type		Wire Spiral	Wire Braid				Textile Braid	TPE Textile Braid
	ISO 6743-4	DIN 51524	DIAMONDSPIR SHIELDMASTER ROCKMASTER GOLDENISO/XF FORESTMASTER	ETERNITY/2 NOZONE 2K	TRACTOR SHIELDMASTER ROCKMASTER HARVESTER/17 GOLDENISO LYTEFLEX COVER	GOLDENISO/LL	EQUATOR	ASTRO SPIRITEX/K MULTITEX PUSH FIT	HYDROPLAST HYDROTWIN
TOTAL LHM (Brake fluid)	HS	-	G	X	C	G	X	G	-
UKABIOL HY 46 HTG	HETG	-	G	G	E	-	G	E	G
UNIL Hydro S46	HM	HLP	G	G	G	-	E	C	G
UNIL Opal HV 46	HV	HVLP	G	G	G	G	E	-	-
UNIL Opal HVB 46	HV	HLPD	G	G	G	-	E	-	-
UNIL Opal PO 6	HV	HVLP	E	G	G	G	G	G	G
UNIL Unihyd ISO WG 46	HV	HLPD	E	G	G	G	E	G	G
VALVOLINE Ultramax HVLP 68	HV	HVLP	G	E	G	G	E	-	-
VICKERS Ecosure HSE 68	HEES	-	G	C	G	G	X	C	-
WISURA WM 3021 2,8% in H2O	HFA	-	E	E	E	-	X	E	E
WURTH Triathlon HLP 46	HM	HLP	E	G	C	G	-	-	-
YORK 777	HEES	-	G	C	G	-	X	G	E
ZELLER+GMELIN Divinol HE 46	HEES	-	E	C	G	E	-	G	-

**WARNING:** Compatibility of hose and fittings with conveyed fluid is an essential factor in avoiding chemical reactions that may result in release of fluids or failure of the hose or connection. This chemical compatibility guide must not be used in conjunction with any other compatibility guides from previous or future catalogue editions, bulletins or publications. Incorrect use of these charts could result in death, personal injury or property damage.

# FLUID COMPATIBILITY CHART

## PART 2: HYDROKINETIC APPLICATIONS AND LUBRICANT OILS COMPATIBILITY CHART

### (AUTOMATIC TRANSMISSION AND VARIOUS LUBRICATION SYSTEMS)

AUTOMATIC TRANSMISSION FLUID (ATF)	TYPE		WIRE SPIRAL DIAMONDSPIR SHIELDMASTER ROCKMASTER GOLDENISO/XF FORESTMASTER	WIRE BRAID				TEXTILE BRAID ASTRO SPIRTEX/K MULTITEX PUSH FIT	TPE TEXTILE BRAID HYDROPLAST HYDROTWIN
	ISO 6743-4	DIN 51524		ETERNITY/2 NOZONE 2K	TRACTOR SHIELDMASTER ROCKMASTER HARVESTER/17 GOLDENISO LYTEFLEX COVER	GOLDENISO/LL	EQUATOR		

AGIP ATF 2D Gear (ATF Dexron II, Mercon II spec)	HA	-	G	G	C	-	G	C	E
AVIA Fluid ATF 86	HA	-	G	G	C	G	E	G	G
BP Autran MBX (ATF Dexron IID) - 100°C	HA	-	E	G	G	G	E	G	-
CASTROL Transynd RD (ATF Allison C4)	HA	-	G	G	C	-	E	-	E
CHEVRON Drivetrain HD (ATF Caterpillar TO4)	HA	-	G	G	C	G	G	C	-
MAG 1 Fully synthetic ATF (ATF Mercon V, Dexron III)	HA	-	-	G	C	-	G	-	-
MILLERS Millermatic ATF UN (ATF Dexron II)	HA	-	-	C	C	-	G	-	-
MOBIL ATF 320	HA	-	G	G	C	G	E	C	G
SHELL ATF III D (ATF Dexron III)	HA	-	G	C	C	G	E	-	-
SHELL Donax ATF III (ATF Dexron III)	HA	-	G	G	C	-	E	G	-
SHELL Donax TX (ATF Dexron III)	HA	-	G	C	C	-	G	-	-
SHELL Spirax S6ATF ZM	HA	-	C	G	X	-	C	-	-
TAMOIL ATF II D (ATF Dexron IID) - 100°C	HA	-	G	G	G	-	E	-	-
TOTAL Fluid NA H3	HA	-	G	G	C	G	E	-	-

GEAR (MECHANICAL TRANSMISSION) FLUID	ISO 6743-4	DIN 51524	DIAMONDSPIR SHIELDMASTER ROCKMASTER GOLDENISO/XF FORESTMASTER	ETERNITY/2 NOZONE 2K	TRACTOR SHIELDMASTER ROCKMASTER HARVESTER/17 GOLDENISO LYTEFLEX COVER	GOLDENISO/LL	EQUATOR	ASTRO SPIRTEX/K MULTITEX PUSH FIT	HYDROPLAST HYDROTWIN
--------------------------------------	------------	-----------	---	-------------------------	---	--------------	---------	---	-------------------------

EXXON MOBIL 424 (gear oil)	C	-	G	G	G	-	G	-	-
FUCHS Planto Hytrac (UTTO gear oil)	C	-	G	C	G	-	C	G	-
LIEBHERR Gear Basic 90 LS (Gearbox oil)	C	-	G	G	G	-	-	G	-

**WARNING:** Compatibility of hose and fittings with conveyed fluid is an essential factor in avoiding chemical reactions that may result in release of fluids or failure of the hose or connection. This chemical compatibility guide must not be used in conjunction with any other compatibility guides from previous or future catalogue editions, bulletins or publications. Incorrect use of these charts could result in death, personal injury or property damage.

# FLUID COMPATIBILITY CHART

GEAR (MECHANICAL TRANSMISSION) FLUID	TYPE		WIRE SPIRAL	WIRE BRAID				TEXTILE BRAID	TPE TEXTILE BRAID
	ISO 6743-4	DIN 51524	DIAMONDSPIR SHIELDMASTER ROCKMASTER GOLDENISO/XF FORESTMASTER	ETERNITY/2 NOZONE 2K	TRACTOR SHIELDMASTER ROCKMASTER HARVESTER/17 GOLDENISO LYTEFLEX COVER	GOLDENISO/LL	EQUATOR	ASTRO SPIRTEX/K MULTITEX PUSH FIT	HYDROPLAST HYDROTWIN

MOBIL SHC PM 320 (Gear oil)	C	-	G	G	C	-	E	-	-
PENZOIL Long Life Gearplus 75w 90	C	-	E	G	G	E	G	G	-
SHELL Donax TD (UTTO gear OIL)	C	-	E	G	G	-	E	-	-
SHELL Omala 320 (Gear oil)	C	-	G	G	C	-	C	G	G
SHELL Omala HD 150 (Gear oil)	C	-	G	G	C	-	C	G	G
SHELL Spirax ASX (Gear oil SAE 80W140)	C	-	G	C	C	-	C	G	-
SHELL Tegula V32 (Gear oil)	C	-	E	G	G	-	E	G	E
TEXACO Textran TDH Premium (UTTO Gear oil)	C	-	E	G	G	G	E	G	-
VALTRA Transmission oil XT 60 (Gearbox)	C	-	G	G	C	-	E	C	-

COMPRESSOR OILS	ISO 6743-4	DIN 51524	DIAMONDSPIR SHIELDMASTER ROCKMASTER GOLDENISO/XF FORESTMASTER	ETERNITY/2 NOZONE 2K	TRACTOR SHIELDMASTER ROCKMASTER HARVESTER/17 GOLDENISO LYTEFLEX COVER	GOLDENISO/LL	EQUATOR	ASTRO SPIRTEX/K MULTITEX PUSH FIT	HYDROPLAST HYDROTWIN
-----------------	------------	-----------	---	-------------------------	---	--------------	---------	--	-------------------------

ANDEROL 497 (Di-ester based compressor oil)	D	-	G	C	G	-	C	G	-
ATLAS COPCO Paroil S BULK (ester based compr. oil)	D	-	G	G	C	-	C	C	-
ATLAS COPCO Roto Foodgrade fluid (Synt blend compr. Oil)	D	-	-	-	-	-	G	-	-
ATLAS COPCO Roto H (mineral based Compressor oil)	D	-	G	G	C	-	G	G	E
ATLAS COPCO Roto Inject Fluid Plus (mineral based compr. Oil)	D	-	G	G	C	-	G	G	E
ATLAS COPCO Roto Inject Fluid (mineral based compr. Oil)	D	-	E	G	G	-	G	G	E
ATLAS COPCO Roto Xtend Duty (PAO compr. Oil)	D	-	-	-	-	-	G	-	-
ATLAS COPCO Roto Z	D	-	-	-	-	-	G	-	-
CASTROL Icematic SW 100 (POE based compressor oil)	D	-	G	G	G	-	-	G	E
CHEVRON Machine oil ISO 32 (Compressor oil)	D	-	G	G	G	-	G	G	G
FUCHS Dea Triton SE 55 (POE based)	D	-	G	G	G	G	-	G	E

**WARNING:** Compatibility of hose and fittings with conveyed fluid is an essential factor in avoiding chemical reactions that may result in release of fluids or failure of the hose or connection. This chemical compatibility guide must not be used in conjunction with any other compatibility guides from previous or future catalogue editions, bulletins or publications. Incorrect use of these charts could result in death, personal injury or property damage.

# FLUID COMPATIBILITY CHART

COMPRESSOR OILS	TYPE		WIRE SPIRAL	WIRE BRAID				TEXTILE BRAID	TPE TEXTILE BRAID
	ISO 6743-4	DIN 51524	DIAMONDSPIR SHIELDMASTER ROCKMASTER GOLDENISO/XF FORESTMASTER	ETERNITY/2 NOZONE 2K	TRACTOR SHIELDMASTER ROCKMASTER HARVESTER/17 GOLDENISO LYTEFLEX COVER	GOLDENISO/LL	EQUATOR	ASTRO SPIRTEX/K MULTITEX PUSH FIT	HYDROPLAST HYDROTWIN

INGERSOLL RAND SSR Ultra plus coolant (POE based compr. oil)	D	-	G	G	G	-	E	G	G
KLUBER Summit Hysyn FG 46 (Synt hydrocarbon comp. Oil)	D	-	G	G	C	G	G	C	-
LUBRIZOL Emkarate RL 100S	D	-	G	G	-	-	-	C	G
MOBIL Arctic EAL 22 (POE based A/C comp. Oil)	D	-	E	E	G	-	G	G	G
MOBIL Glycol 30 (PAG based comp.oil)	D	-	E	E	E	E	E	E	G
MOBIL Rarus SHC 1026 (Compressor oil)	D	-	E	G	G	-	E	G	-
PAG SP 10 (compressor oil)	D	-	G	G	G	-	-	C	E
SHELL Corena D (compressor oil)	D	-	G	G	C	-	E	C	G
SULLAIR AWF	D	-	-	-	-	-	G	-	-
TOTAL Dacnis SH 46 (PAO based comp. Oil)	D	-	-	G	G	G	E	G	-
TOTAL Dacnis VS 46 (mineral based comp. Oil)	D	-	G	G	G	G	E	C	-
VALVOLINE Valcomp Synth 68 Comp. Oil	D	-	-	-	-	-	G	-	-

ENGINE OILS	ISO 6743-4	DIN 51524	DIAMONDSPIR SHIELDMASTER ROCKMASTER GOLDENISO/XF FORESTMASTER	ETERNITY/2 NOZONE 2K	TRACTOR SHIELDMASTER ROCKMASTER HARVESTER/17 GOLDENISO LYTEFLEX COVER	GOLDENISO/LL	EQUATOR	ASTRO SPIRTEX/K MULTITEX PUSH FIT	HYDROPLAST HYDROTWIN
-------------	------------	-----------	---	-------------------------	---	--------------	---------	--	-------------------------

AGIP SINT 2000 (engine oil 10W40)	E	-	G	G	G	-	G	E	G
AGIP Tec sint SL5W40 (engine oil 5W40)	E	-	E	G	C	-	G	-	-
BP Vanellus C 5 (engine oil 15W40)	E	-	E	G	G	G	G	-	-
CHEVRON Delo 400LE (Engine oil 15W40)	E	-	G	G	C	G	G	G	-
CHEVRON RPM 30 (Engine oil)	E	-	G	G	G	G	E	G	-
FUCHS Plantohydramot SL 5W40 (STOU engine oil)	E	-	G	G	C	G	G	G	-
FUCHS Titan GTI Pro C 2 (Engine oil 5W30)	E	-	G	G	G	-	C	G	-
IGOL Marine 15W-40 (engine oil )	E	-	G	G	G	-	-	-	-

**WARNING:** Compatibility of hose and fittings with conveyed fluid is an essential factor in avoiding chemical reactions that may result in release of fluids or failure of the hose or connection. This chemical compatibility guide must not be used in conjunction with any other compatibility guides from previous or future catalogue editions, bulletins or publications. Incorrect use of these charts could result in death, personal injury or property damage.

# FLUID COMPATIBILITY CHART

TURBINE OILS	TYPE		WIRE SPIRAL	WIRE BRAID				TEXTILE BRAID	TPE TEXTILE BRAID
	ISO 6743-4	DIN 51524	DIAMONDSPIR SHIELDMASTER ROCKMASTER GOLDENISO/XF FORESTMASTER	ETERNITY/2 NOZONE 2K	TRACTOR SHIELDMASTER ROCKMASTER HARVESTER/17 GOLDENISO LYTEFLEX COVER	GOLDENISO/LL	EQUATOR	ASTRO SPIRTEX/K MULTITEX PUSH FIT	HYDROPLAST HYDROTWIN

JCB Engine oil EP (Engine oil 15W40)	E	-	E	G	G	-	G	G	G
MOBIL Delvac 1310 (engine oil 10W20)	E	-	E	G	G	-	G	E	G
Q8 T720 (engine oil 15w40)	E	-	E	G	G	-	E	G	-
SHELL Helix Ultra (Engine oil 5W40)	E	-	G	G	G	-	E	G	-
SHELL Rimula R3 (Engine oil 10W)	E	-	E	G	G	-	E	G	E
SHELL Rimula X30 (Engine oil 10W)	E	-	E	G	G	G	E	G	E
SHELL Rotella TMG (Engine oil 15W40)	E	-	G	G	G	G	E	G	-
SHELL V oil 1404	E	-	G	G	G	-	G	G	G
MOBIL Jet oil II	T	-	E	C	G	E	C	E	-
NYCO Turbonicoil TN 13 B	T	-	G	X	X	G	X	E	-

HEAT TRANSFER FLUIDS	ISO 6743-4	DIN 51524	DIAMONDSPIR SHIELDMASTER ROCKMASTER GOLDENISO/XF FORESTMASTER	ETERNITY/2 NOZONE 2K	TRACTOR SHIELDMASTER ROCKMASTER HARVESTER/17 GOLDENISO LYTEFLEX COVER	GOLDENISO/LL	EQUATOR	ASTRO SPIRTEX/K MULTITEX PUSH FIT	HYDROPLAST HYDROTWIN
----------------------	------------	-----------	---	-------------------------	---	--------------	---------	--	-------------------------

CHEVRON Havoline XLC (Fluid cooler)	Q	-	E	G	G	-	X	G	-
MOBIL Therm 605	Q	-	G	G	G	-	E	G	-
NESTE Fluid cooler BIO	Q	-	E	G	G	G	-	G	-
NESTE Super fluid cooler XLC	Q	-	E	G	G	-	-	G	-
PETROCANADA Calflo (Heat transfer fluid)	Q	-	G	G	G	E	G	G	-
PETRONAS Paraflo HT (OAT) at 100°C	Q	-	E	G	G	-	X	G	-
Water Glycol emulsion (50%) at 100°C	Q	-	E	G	G	-	X	G	E

**WARNING:** Compatibility of hose and fittings with conveyed fluid is an essential factor in avoiding chemical reactions that may result in release of fluids or failure of the hose or connection. This chemical compatibility guide must not be used in conjunction with any other compatibility guides from previous or future catalogue editions, bulletins or publications. Incorrect use of these charts could result in death, personal injury or property damage.



# FLUID COMPATIBILITY CHART

METAL WORKING FLUIDS	TYPE		WIRE SPIRAL	WIRE BRAID				TEXTILE BRAID	TPE TEXTILE BRAID
	ISO 6743-4	DIN 51524	DIAMONDSPIR SHIELDMASTER ROCKMASTER GOLDENISO/XF FORESTMASTER	ETERNITY/2 NOZONE 2K	TRACTOR SHIELDMASTER ROCKMASTER HARVESTER/17 GOLDENISO LYTEFLEX COVER	GOLDENISO/LL	EQUATOR	ASTRO SPIRTEX/K MULTITEX PUSH FIT	HYDROPLAST HYDROTWIN
BUDEMEIM Phosphatherm 948	M	-	E	E	E	-	X	E	-

**WARNING:** Compatibility of hose and fittings with conveyed fluid is an essential factor in avoiding chemical reactions that may result in release of fluids or failure of the hose or connection. This chemical compatibility guide must not be used in conjunction with any other compatibility guides from previous or future catalogue editions, bulletins or publications. Incorrect use of these charts could result in death, personal injury or property damage.

# FLUID COMPATIBILITY CHART

## PART 3: BEHAVIOUR TO CHEMICALS FOR NON-HYDRAULIC APPLICATIONS (GUIDELINES FROM LITERATURE)

FLUID	NITRILE	CHLOROPRENE	CHLOROSULPHONATED POLYETHYLENE	CHLORINATED POLYETHYLENE	POLYESTER
Acetaldeide	X	C	X	C	G
Acetic Acid, 10%	X	C	G	G	G
Acetic Acid glacial	X	X	C	G	C
Acetone	C	C	X	G	G
Air (60°C)	G	G	E	E	E
Air (100°C)	C	G	E	E	G
Air (150°C)	X	X	G	G	X
Ammonia, gaseous	C	G	-	-	X
Ammonia, liquid cold	E	E	G	-	X
Ammonia, liquid 70°C	X	C	C	-	X
Ammonium Hydroxide, 10%	G	G	E	E	-
Ammonium Hydroxide, conc	C	C	C	C	-
Ammonium nitrate (aqueous solutions)	G	G	G	G	G
Ammonium phosphate, mon-di-tri basic (aq. Sol)	E	E	E	E	C
Ammonium sulphate (aqueous solution)	E	E	E	E	C
Aniline	X	C	X	X	X
Aqua regia	C	C	X	C	-
ASTM oil n°1, 100°C	E	E	G	G	E
ASTM oil n°2, 100°C	E	G	C	C	E
ASTM oil n°3, 100°C	E	C	C	C	E
Benzene	X	X	X	C	C
Boric acid 10% 100°C	G	G	G	X	G
Brake fluid (SAE J 1703d)	X	-	X	G	-
Brine	E	C	C	G	G
Butanol	E	G	G	G	E

**WARNING:** No tests on finished hose assemblies in combination with the mentioned chemicals has been normally performed. The possible good rating and on field performance of the hose with a chemical mentioned in the list, does not mean in any case the release by Manuli Hydraulics of the product for that application or any guarantee. The possible validation for use is under the sole and exclusive responsibility of the end user and no liability whatsoever can be attributed to Manuli Hydraulics in that regard. In fact Manuli Hydraulics hoses are designed for hydraulics use and applications, they are not intended for industrial diversified applications with various chemicals. No tests on finished hose assemblies in combination with the mentioned chemicals has been normally performed.

# FLUID COMPATIBILITY CHART

FLUID	NITRILE	CHLOROPRENE	CHLOROSULPHONATED POLYETHYLENE	CHLORINATED POLYETHYLENE	POLYESTER
Calcium bicarbonate	E	E	E	E	-
Calcium hydroxide (Aqueous suspensions)	E	E	G	G	-
Carbonic anhydride	G	E	G	G	E
Chlorine	X	X	X	X	X
Chloroform	C	C	X	X	X
Citric Acid, 33%	G	G	G	-	E
Crude oil	E	X	X	X	G
Detergent water solution	G	G	C	G	G
Dibenzyl ether	X	X	X	X	-
Diethyl phtalate (DEPH)	C	X	X	X	E
Epichlorhydrine	X	X	C	X	X
Ethyl acetate	C	X	C	C	G
Ethyl alcohol	E	E	E	E	E
Ethyl ether	G	C	-	-	-
Ethylene	E	G	-	-	G
Ethylene glycole	E	E	G	G	E
Ethylene glycole (100°C)	E	G	G	G	G
Formaldehyde	C	G	C	G	G
Formic acid 23°C (saturated solution)	G	G	G	X	G
Formic acid 75°C (saturated solution)	C	G	C	X	C
Glycerine	E	E	E	E	E
Heptane	G	C	X	C	E
Hydraulic oils (see detailed table)	*	*	*	*	*
Hydrochloric acid, 10%	G	G	G	X	G
Hydrochloric acid, 37%	C	C	C	X	X
Hydrochloric acid, 37% 70°C	X	X	X	X	X
Hydrocyanic acid 20%	C	C	-	-	-
Hydrogen sulphide	C	G	C	X	E

**WARNING:** No tests on finished hose assemblies in combination with the mentioned chemicals has been normally performed. The possible good rating and on field performance of the hose with a chemical mentioned in the list, does not mean in any case the release by Manuli Hydraulics of the product for that application or any guarantee. The possible validation for use is under the sole and exclusive responsibility of the end user and no liability whatsoever can be attributed to Manuli Hydraulics in that regard. In fact Manuli Hydraulics hoses are designed for hydraulics use and applications, they are not intended for industrial diversified applications with various chemicals. No tests on finished hose assemblies in combination with the mentioned chemicals has been normally performed.

# FLUID COMPATIBILITY CHART

FLUID	NITRILE	CHLOROPRENE	CHLOROSULPHONATED POLYETHYLENE	CHLORINATED POLYETHYLENE	POLYESTER
Isobutyl alcohol	G	G	G	G	E
Isopropyl alcohol	G	E	E	E	E
Iso-octane	G	C	X	C	E
Kerosene (aromatics 40%max, 70°C)	G	C	X	C	-
Lead free petrol	G	C	X	C	E
Magnesium hydroxide (aqueous solutions)	G	E	E	E	-
Mercury	E	E	E	E	E
Methanol	G	E	E	E	G
Methyl methacrylate	X	X	X	X	-
Methylethylketone (MEK)	X	C	X	C	E
Nitric acid, concentrated 65%	X	X	X	X	X
Nitric acid, diluted 10% 50°C	C	X	X	C	X
Nitric acid fuming	X	X	X	X	X
Nitrogen	E	E	E	E	E
Oleic acid	G	C	C	C	E
Oleum	X	X	X	X	X
Oxalic acid 25% 80°C	G	E	G	X	-
Oxygen (80°C)	C	G	C	G	E
Paraffin	E	E	C	E	E
Pentane	G	C	X	C	E
Petrol	E	C	X	C	E
Petroleum, 70°C	E	G	X	C	E
Phenol	X	X	X	X	C
Phosphoric acid 20%	G	E	E	X	-
Phosphoric acid 60% 50°C	C	G	C	X	-
Phosphoric acid 85%	C	G	C	X	-
Phosphorous tri-chloride	X	X	X	X	-
Picric acid 10% 100°C	C	C	G	G	-

**WARNING:** No tests on finished hose assemblies in combination with the mentioned chemicals has been normally performed. The possible good rating and on field performance of the hose with a chemical mentioned in the list, does not mean in any case the release by Manuli Hydraulics of the product for that application or any guarantee. The possible validation for use is under the sole and exclusive responsibility of the end user and no liability whatsoever can be attributed to Manuli Hydraulics in that regard. In fact Manuli Hydraulics hoses are designed for hydraulics use and applications, they are not intended for industrial diversified applications with various chemicals. No tests on finished hose assemblies in combination with the mentioned chemicals has been normally performed.

# FLUID COMPATIBILITY CHART

FLUID	NITRILE	CHLOROPRENE	CHLOROSULPHONATED POLYETHYLENE	CHLORINATED POLYETHYLENE	POLYESTER
Potassium chloride (aqueous solution)	E	E	E	E	-
Potassium hydroxide 70°C (medium high conc.)	G	G	-	-	E
Potassium sulphate (aqueous solution)	E	E	E	E	-
Sea water	E	G	C	G	E
Soaps	E	G	G	G	E
Soda caustic	C	G	G	C	G
Sodium bicarbonate	E	E	E	E	G
Sodium chloride (aqueous solution)	E	E	G	G	E
Sodium hydroxide	C	G	G	C	E
Sodium hydroxide 70°C (medium high conc.)	C	G	G	C	F
Sodium hypochlorite (aqueous solutions)	C	G	C	X	E
Sodium silicate (aqueous solutions)	E	E	E	E	-
Sodium sulphate (aqueous solution)	E	E	E	E	-
Sodium sulphide	E	E	E	E	-
Stearic acid	E	E	C	E	E
Sulphur	X	X	G	G	-
Sulphur dioxide	X	X	X	X	-
Sulphuric acid (hot concentrated 96°C)	X	X	X	X	X
Sulphuric acid (diluted 20%)	X	X	C	C	E
Sulphuric anhydride	X	C	C	C	-
Sulphurous acid	X	X	C	C	X
Tannic acid	G	G	G	X	E
Tannin	E	E	E	E	E
Tartaric acid 20%	E	G	G	X	-
Tetraethyl lead	G	C	X	-	-
Toluene	X	X	X	X	E
Turpentine	G	X	X	X	-
Urea	E	E	G	G	-

**WARNING:** No tests on finished hose assemblies in combination with the mentioned chemicals has been normally performed. The possible good rating and on field performance of the hose with a chemical mentioned in the list, does not mean in any case the release by Manuli Hydraulics of the product for that application or any guarantee. The possible validation for use is under the sole and exclusive responsibility of the end user and no liability whatsoever can be attributed to Manuli Hydraulics in that regard. In fact Manuli Hydraulics hoses are designed for hydraulics use and applications, they are not intended for industrial diversified applications with various chemicals. No tests on finished hose assemblies in combination with the mentioned chemicals has been normally performed.

# FLUID COMPATIBILITY CHART

FLUID	NITRILE	CHLOROPRENE	CHLOROSULPHONATED POLYETHYLENE	CHLORINATED POLYETHYLENE	POLYESTER
Vinyl acetate	C	C	C	G	-
Vinyl chloride	X	X	X	X	-
Water	E	G	X	G	E
Xylene	C	X	X	X	G
Zinc chloride (aqueous solutions)	E	E	G	X	E
Zinc sulphate (aqueous solutions)	E	E	G	X	-

**WARNING:** No tests on finished hose assemblies in combination with the mentioned chemicals has been normally performed. The possible good rating and on field performance of the hose with a chemical mentioned in the list, does not mean in any case the release by Manuli Hydraulics of the product for that application or any guarantee. The possible validation for use is under the sole and exclusive responsibility of the end user and no liability whatsoever can be attributed to Manuli Hydraulics in that regard. In fact Manuli Hydraulics hoses are designed for hydraulics use and applications, they are not intended for industrial diversified applications with various chemicals. No tests on finished hose assemblies in combination with the mentioned chemicals has been normally performed.



# EASY FIT

## DIRECT TO PORT CONCEPT

The male threadless termination can be connected directly to the port, by means of pre-installed cartridge, with a simple axial pushing action of the fitting into the port.

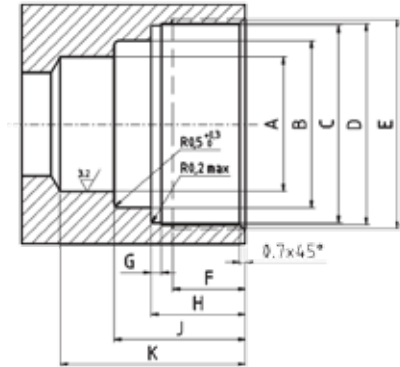

## FEMALE PORT DESIGN

SIZE	DIMENSIONS (MM)					RECOMMENDED TORQUE
	A	B	C	D	E	
-04	10.03 + 0.08	12.75 + 0.1	16.55 + 0.07	17.0 + 0.1	M18 x 1	23 - 35 Nm
-06	13.03 + 0.08	16.9 + 0.2	20.55 + 0.07	21.0 + 0.1	M22 x 1	30 - 40 Nm
-08	16.03 + 0.08	19.9 + 0.2	23.55 + 0.07	24.0 + 0.1	M25 x 1	40 - 50 Nm
-12	23.03 + 0.08	27.9 + 0.2	31.05 + 0.07	31.5 + 0.1	M33 x 1.5	70 - 80 Nm

SIZE	DIMENSIONS (MM)					RECOMMENDED TORQUE
	F	G	H	J	K	
-04	8.5 + 1	1.1 - 0.1	10.35 + 0.1	14.15 + 0.2	19.56 + 0.15	23 - 35 Nm
-06	8.7 + 1	1.15 - 0.1	11.1 + 0.1	15.5 + 0.2	21.95 + 0.15	30 - 40 Nm
-08	8.7 + 1	1.25 - 0.1	11.3 + 0.1	15.7 + 0.2	22.15 + 0.15	40 - 50 Nm
-12	11.5 + 1	1.7 - 0.1	16.5 + 0.1	21.4 + 0.2	31.35 + 0.15	70 - 80 Nm



## ASSEMBLING INSTRUCTIONS

### ASSEMBLING PROCEDURE

1

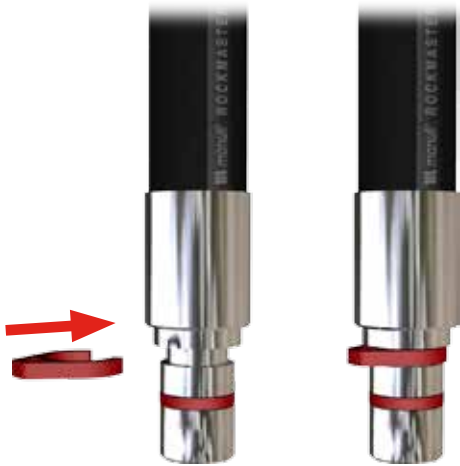

Fit the safety clip into the dedicated groove on the male fitting.

2

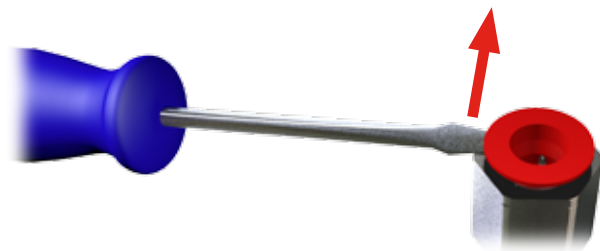

Use a flat-headed screwdriver, or similar tool, to remove the protective cap on the cartridge.

3



Connect the fitting by pushing it into the cartridge.

The fitting is correctly locked and connected when the safety clip touches the cartridge.

## ASSEMBLING INSTRUCTIONS

When inserting the male fitting into the cartridge, the axial force required to ensure correct and secure assembly will vary throughout the insertion process (see graph opposite). In particular there will be a two points where the amount of force required will be noticeably higher.

The first peak (A), occurs when the internal collars of the cartridge are opening; For a -08 fitting this would typically be around 20 kgf.

The second peak (B), occurs when the plastic retaining ring is being inserted into the cartridge. This peak is significantly lower than the first.

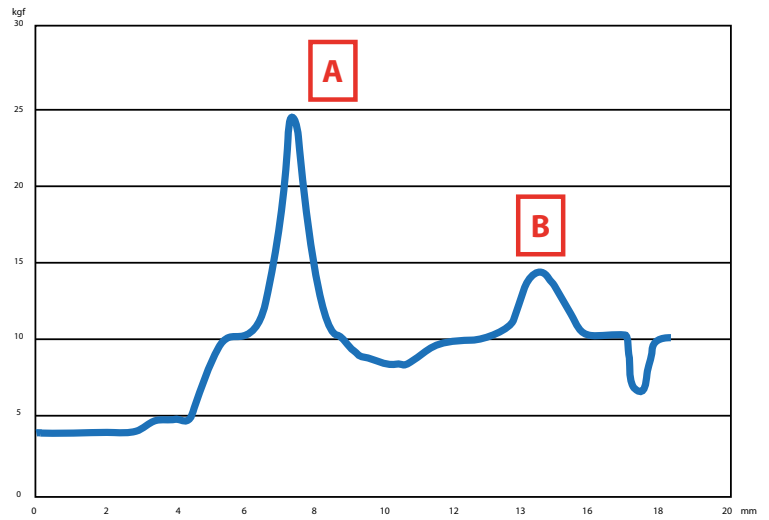

## DISASSEMBLING INSTRUCTIONS

### DISASSEMBLING PROCEDURE



Before disconnection, ensure the system is not under pressure



- 1 Use a flat-headed screwdriver, or similar tool, to remove the safety clip.

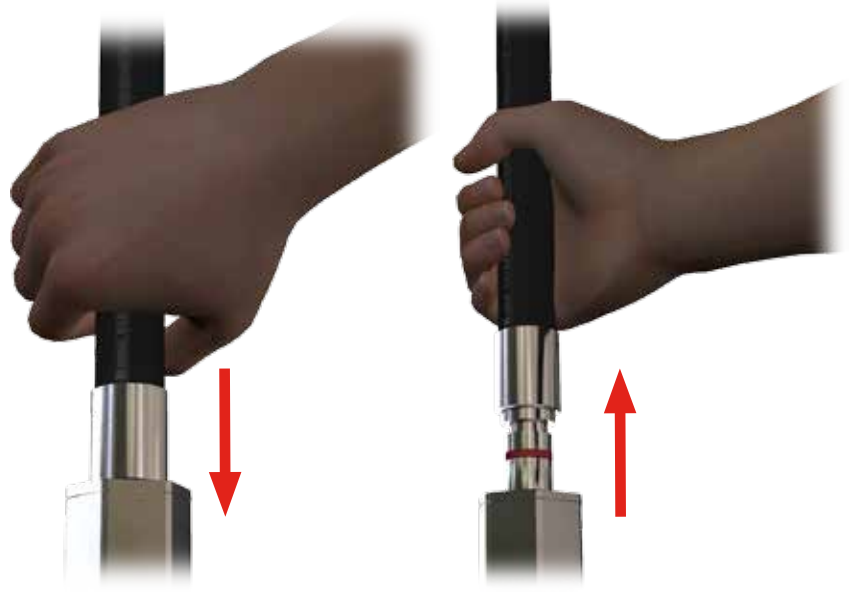

- 2 Push the fitting in until the collar touches the cartridge, then pull out to complete the disconnection process.

# EASY FIT

## DISASSEMBLING INSTRUCTIONS

The maximum axial force required to separate the components (after the initial "push") is approximately 10 kgf for a -08 fitting - see graph opposite.

The peak (C) represents the force required to open the internal retaining ring to allow the withdrawal of the male fitting.

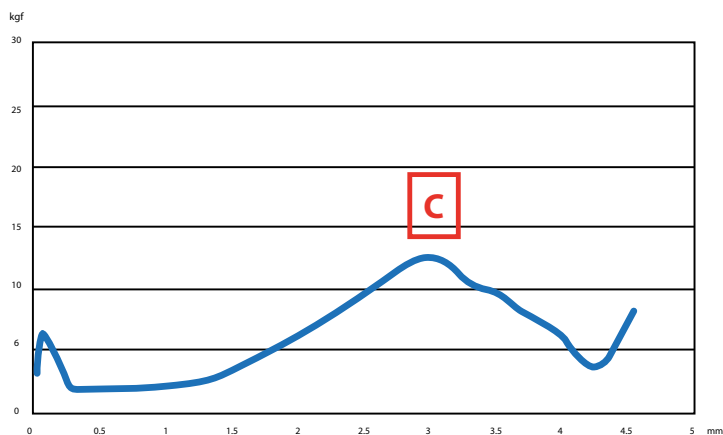

## REPLACEMENT INSTRUCTIONS

### O-RING AND BACK-UP RING SEAL REPLACEMENT ON FEMALE COUPLINGS

1

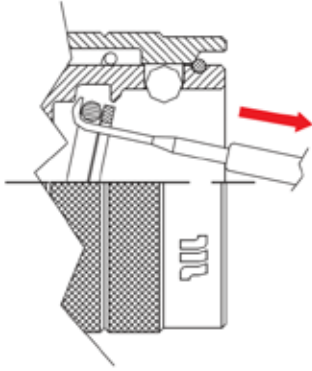

Remove the damaged O-ring and back-up ring



**Do not use sharpened tools.  
Take care not to damage the components.**

2

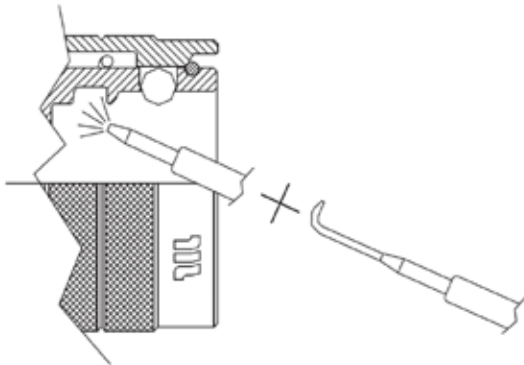

Clean the seal area



**Remove all residual parts of damaged  
O-ring and back-up ring.**

3

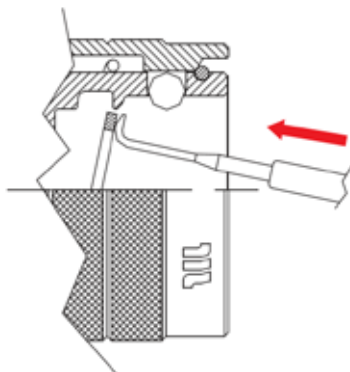

Insert the new back-up ring



**Take care not to deform or scratch the  
back-up ring.  
Ensure the back-up ring is correctly  
located in it's seat.**

## REPLACEMENT INSTRUCTIONS

4

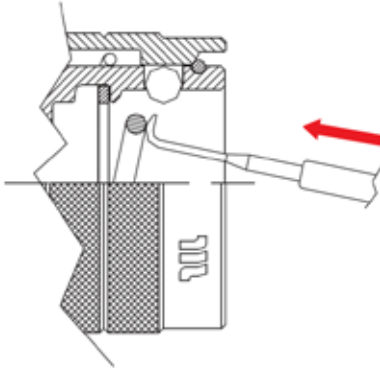

Insert the new O-ring



**Lubricate the O-ring before inserting. Take care not to scratch the O-ring. Ensure the O-ring is correctly located in its seat.**

5

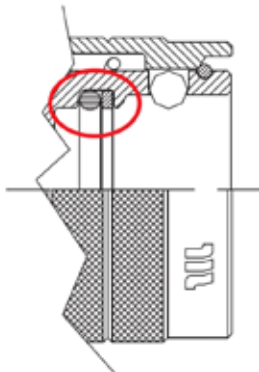

The replacement process is now complete



**Lubricate the seal system.**

## REPLACEMENT INSTRUCTIONS

### POLYURETHANE SEAL REPLACEMENT ON MALE FLAT-FACE

1

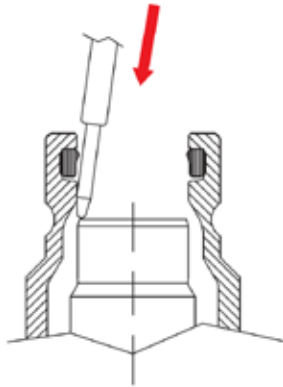

Use a suitable tool to pull back the valve and hold it in place



**Do not use sharpened tools.  
Take care not to damage the components.**

2

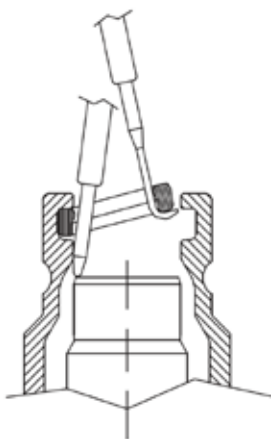

Remove the damaged seal



**Take care not to damage the components.**

3

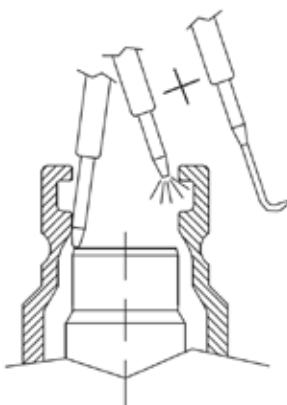

Clean the seal area



**Remove all residual parts of polyurethane seal.**

## REPLACEMENT INSTRUCTIONS

4

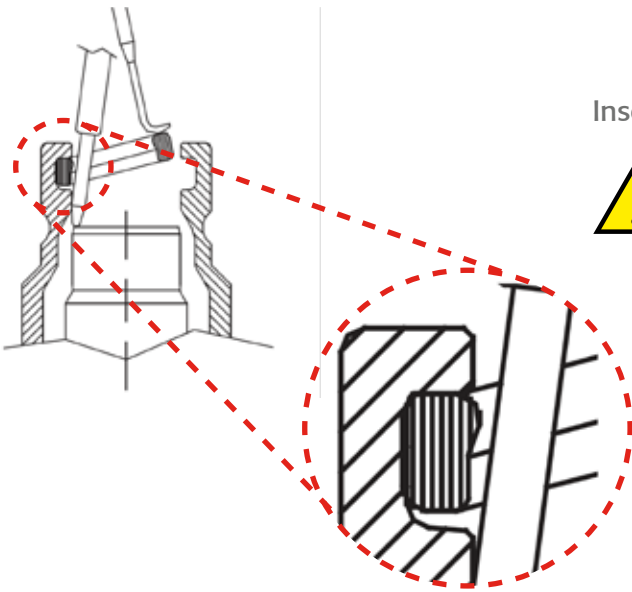

Insert the new seal, ensuring it is correctly orientated



**Lubricate the seal before inserting.  
Take care not to scratch the seal.  
Ensure the seal is correctly located in it's seat.**

5

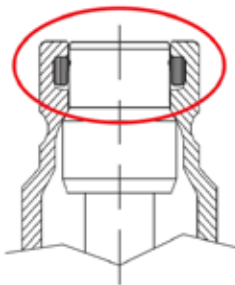

Release the valve to complete the replacement process



**Lubricate the seal system.**



# PART NUMBERING SYSTEM

## HOSES

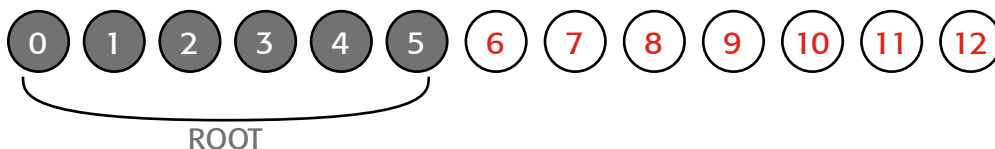

"H" letter always means "Hoses"



### Family

"Five digit number" that defines a specific hose family - see "Hose Family Table".

Digit "1"	Hose Type
0	Hydraulic rubber hose
2	Thermoplastic hose
3	Traded hose
7	Oil & marine hose
8	Industrial hose
9	PTFE hose

Digits "1-2"	Hose Type
10	Hydraulic rubber hose
16	Textile braided - Traded



Progressive letter (A, B, ...) is used to identify an updated structure

In case a number is used, it must be read together with digits "7" and "8" to identify the hose's diameter in mm



### Diameter in millimetres

In case digit "6" is a number, the hose diameter in millimetres should be read including it.



Value	Package	Marking Technology
0	Box	Ink transfer
B	Reel	Ink transfer
P	Plastic reel	Ink transfer
R	Roll	Ink transfer
W	Wooden reel	Ink transfer
E	Defined in digit "10"	Embossed / embedded
I	Defined in digit "10"	Inkjet
M	Defined in digit "10"	Mylar

# PART NUMBERING SYSTEM

## HOSES (CONTINUED)

### DIGIT "10"



Value	Package	Special
L	Box ( $\leq$ DN51); Wooden reel ( $>$ DN51)	Branding with License Number
O	Box	-
B	Reel	-
P	Plastic reel	-
R	Roll	-
W	Wooden reel	-
A	Box	100 ft (spiralled) / 50 ft (GoldenBlast)
Q	Box	40 m (GoldenBlast)
S, V, Z, Y	Box	Special length
C	-	Branding without "Made in..." declaration

### DIGIT "11"



Value	Special
S, V, Z, Y	Special length
C	Branding without "Made in..." declaration
9	Manuli standard branding
0-8	Private brand

### DIGIT "12"



Value	Special
9	Manuli standard branding
0-8	Private brand

### Notes for digits "9-10-11-12"

If the above convention is NOT followed then the branding is considered "Private". Exceptions related to "Manuli Brand" hoses are: x900; xx90; x556; x833; x962; xx97; xx95

# PART NUMBERING SYSTEM

## HOSE FAMILIES

First 6 Digits	Prod. Tech.	Prod. Tech. Description	Family	Family Description
H01006	1	Wire Braided	6	TRACTOR/1SN
H01007	1	Wire Braided	7	ROCKMASTER/1SN
H01013	1	Wire Braided	13	TRACTOR/1SC
H01015	1	Wire Braided	15	PILOT
H01025	1	Wire Braided	25	TRACTOR/2SC
H01027	1	Wire Braided	27	TRACTOR/2SN
H01030	1	Wire Braided	30	ROCKMASTER/2SC
H01031	1	"Wire Braided; Wire Spiralled"	31	SHIELDMASTER/4000
H01032	1	"Wire Braided; Wire Spiralled"	32	SHIELDMASTER/5000
H01033	1	Wire Braided	33	CPH/2SC
H01034	1	Wire Braided	34	JACKMASTER
H01035	1	Wire Braided	35	ROCKMASTER/2ST
H01038	1	Wire Braided	38	ROCKMASTER/2SN
H01039	1	Wire Braided	39	NOZONE/2K
H01056	1	Wire Braided	56	HARVESTER/17
H01058	1	Wire Braided	58	EQUATOR/1 BLACK
H01059	1	Wire Braided	59	EQUATOR/1 BLUE
H01060	1	Wire Braided	60	EQUATOR/2 BLACK
H01061	1	Wire Braided	61	EQUATOR/2 BLUE
H01084	1	Wire Braided	84	LYTE-FLEX
H01101	1	Wire Braided	101	ROCKMASTER/2 PLUS
H01102	1	Wire Braided	102	ETERNITY/2
H01104	1	"Wire Braided; Wire Spiralled"	104	SHIELDMASTER/5000 MINE
H01105	1	Wire Braided	105	SHIELDMASTER/2SC MINE
H01106	1	Wire Braided	106	SHIELDMASTER/2000
H01108	1	Wire Braided	108	ROCKMASTER/1SC
H01110	1	Wire Braided	110	REFRISTAR
H01112	1	Wire Braided	112	TWINPOWER/PLUS
H01113	1	Wire Braided	113	FLUICONNECTO 2SN
H01119	1	Wire Braided	119	TWINPOWER 4000
H01120	1	Wire Braided	120	TWINPOWER 5000
H01122	1	Wire Braided	122	SHIELDMASTER/2 PLUS MINE
H01124	1	Wire Braided	124	FIREND
H01125	1	Wire Braided	125	GOLDENISO/21 ANTIWEAR
H01126	1	Wire Braided	126	GOLDENISO/28 ANTIWEAR
H01127	1	Wire Braided	127	TREX

# PART NUMBERING SYSTEM

## HOSE FAMILIES (CONTINUED)

First 6 Digits	Prod. Tech.	Prod. Tech. Description	Family	Family Description
H01128	1	Wire Braided	128	XTRAFLOW/ HT
H01129	1	Wire Braided	129	XTRAFLOW/2WB
H01133	1	Wire Braided	133	ULTRASTAR
H01134	1	Wire Braided	134	GOLDENISO/35 LONGLIFE
H01135	1	Wire Braided	135	LUBEMASTER
H01A32	1	"Wire Braided; Wire Spiralled "	A32	SHIELDMASTER/6000
H01A78	1	Wire Braided	A78	SUPERJET/PLUS
H01A79	1	Wire Braided	A79	SUPERJET/PLUS BLUE
H01A94	1	Wire Braided	A94	PROJET
H01A95	1	Wire Braided	A95	PROJET BLUE
H02001	2	Smooth Hoses	1	SUPERJET
H02002	2	Smooth Hoses	2	SUPERJET BLUE
H02003	2	Smooth Hoses	3	K-JET
H02004	2	Smooth Hoses	4	TRACTOR/1SN
H02008	2	Smooth Hoses	8	K-JET BLUE
H02011	2	Smooth Hoses	11	GOLDENISO/14
H05002	5	Wire Braided (R5 hose type)	2	COVER
H09002	9	Textile	2	REFRIMASTER
H09045	9	Textile	45	ASTRO/2
H09046	9	Textile	46	ASTRO/3
H09066	9	Textile	66	PUSHFIT
H09067	9	Textile	67	MULTITEX
H09069	9	Textile	69	MASTERTEX
H09071	9	Textile	71	REFRIMASTER PLUS
H09073	9	Textile	73	MULTITEX
H10008	10	Wire Spiralled	8	ROCKMASTER/4SP
H10018	10	Wire Spiralled	18	DIAMONDSPIR
H10031	10	Wire Spiralled	31	ROCKMASTER/12
H10035	10	Wire Spiralled	35	ROCKMASTER/13
H10044	10	Wire Spiralled	44	ROCKMASTER/4SH
H10049	10	Wire Spiralled	49	ROCKMASTER/15
H10066	10	Wire Spiralled	66	GOLDENBLAST/PLUS
H10067	10	Wire Spiralled	67	GOLDENBLAST/SIX
H10072	10	Wire Spiralled	72	GOLDENBLAST
H10086	10	Wire Spiralled	86	SHIELDMASTER/6000 MINE
H10089	10	Wire Spiralled	89	GOLDENISO/45 LONGLIFE

# PART NUMBERING SYSTEM

## HOSE FAMILIES (CONTINUED)

First 6 Digits	Prod. Tech.	Prod. Tech. Description	Family	Family Description
H10091	10	Wire Spiralled	91	XTRAFLOW/4WS
H10093	10	Wire Spiralled	93	GOLDENISO/21 XTRAFLEX
H10095	10	Wire Spiralled	95	GOLDENISO/28 XTRAFLEX
H10096	10	Wire Spiralled	96	GOLDENISO/35 XTRAFLEX
H10097	10	Wire Spiralled	97	GOLDENISO/42 XTRAFLEX
H10098	10	Wire Spiralled	98	GOLDENISO/38 LONGLIFE
H10102	10	Wire Spiralled	102	DIAMONDSPIR/21
H10103	10	Wire Spiralled	103	DIAMONDSPIR/35
H10104	10	Wire Spiralled	104	DIAMONDSPIR/14
H10108	10	Wire Spiralled	108	GOLDENISO/50 DIAMOND
H10109	10	Wire Spiralled	109	GOLDENISO/56 DIAMOND
H30005	30	Textile, helix wire	5	SPIRTEX/K
H30010	30	Thermoplastic	10	HYDROPLAST
H30011	30	Thermoplastic	11	HYDROTWIN

# PART NUMBERING SYSTEM

## FERRULES

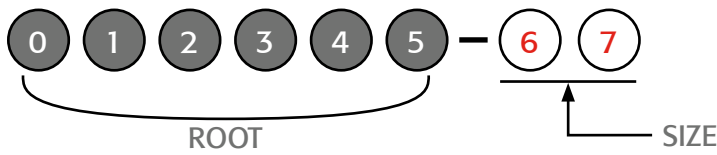

### DIGIT "0"



#### Value

#### Ferrule Type

M	Ferrule MF2000
C	Ferrule or clamp A/C
K	Reusable ferrule

### DIGIT "1"



#### Value

#### Description

0	Always
---	--------

### DIGITS "2-3"



Refer to Ferrule Series table.

### DIGIT "4"



#### Value

#### Issue of Ferrule

0	First issue of ferrule series
1	Second issue of ferrule series
2	Third issue of ferrule series
3	Fourth issue of ferrule series

### DIGIT "5"



#### Value

#### Special

0	Standard
1	Customised version
2	Customised version
...	...

### DIGITS "6-7"



Hose bore size

# PART NUMBERING SYSTEM

## FERRULE SERIES

Digits	Description
01	Skive Ferrule for W.B Hoses
03	No-Skive Ferrule for Textile Braided Hoses / Star-Crimp Ferrule AC for RefriStar
04	Reusable Star-Fit Ferrule AC for RefriStar
07	Refrimaster Ferrule AC
08	No-Skive Ferrule for Compact Hoses
09	Skive Ferrule for W.B and W.S Hoses
10	Refrimaster Clamp
13	Double Skive Ferrule for H.D. Spiral Hoses (Interlock 4-6 ply)
14	Double Skive Ferrule for H.D. Spiral Hoses (Interlock 4 ply)
15	Double Skive Ferrule for H.D. Spiral Hoses (Interlock Plus 4 ply)
16	Double Skive Ferrule for H.D. Spiral Hoses (Interlock Plus 6 ply)
17	Double Skive Ferrule for Extra Duty Spiral Hoses (Blastlock-Xtralock 4 ply)
18	Double Skive Ferrule for Extra Duty Spiral Hoses (Blastlock-Xtralock 6 ply)
24	No-Skive Ferrule for Minifit
26	Double Skive Ferrule for Extra Duty Spiral Hoses (Interlock Super)
28	Double Skive Ferrule for Extra Duty Spiral Hoses (Interlock Super)
31	No-Skive Ferrule for 1 W.B. Hoses
33	No-Skive Ferrule for W.B. Hoses
34	No-Skive Ferrule for W.B. Hoses
54	No-Skive Ferrule for 4 W.S. - 2 W.B. Hoses (Spiralfit)
55	No-Skive Ferrule for 4 W.S. - 6 W.S. Hoses (Spiralfit)
90	Frigostar Clamp

# PART NUMBERING SYSTEM

## SPECIAL FERRULES

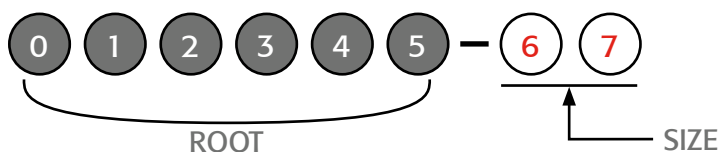

### DIGIT "0"



#### Value

#### Description

J

Always means "Accessories"

### DIGIT "1"



#### Value

#### Ferrule Type

B

Always means "Special Ferrule"

### DIGITS "2-3"



#### Value

#### Hose Type

01

Ferrule for PTFE hose

### DIGIT "4"



The progressive number in this position specifies the customisation / release

### DIGIT "5"



#### Value

#### Material

2

Carbon steel

3

Stainless steel

### DIGITS "6-7"



Hose bore size



# PART NUMBERING SYSTEM

## TWO-PIECE HYDRAULIC FITTINGS

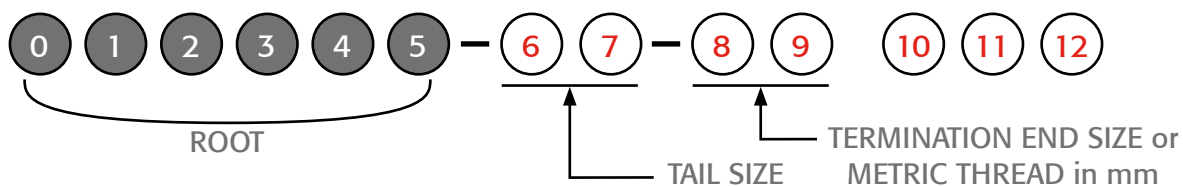

### DIGIT "0"



#### Value

#### Description

M	MF2000 Connector (Multifit, Interlock, Xtralock, ...)
O	Accessories (banjo, flange clamps, bolt, ...)
L	Push-Lock Connector

### DIGIT "1"



#### Value

#### Description

1	Male or Double connector type Multifit
2	Female or Flange type Multifit
3	Male or Double connector type Interlock and Interlock Plus
4	Female or Flange type Interlock and Interlock Plus
5	Male or Double connector type Xtralock
6	Female or Flange type Xtralock
7	Male or Double connector type Spiralfit
8	Female or Flange type Spiralfit / Accessories (flange clamps and bolt)
A	Male or Double connector type Interlock Super
B	Female or Flange type Interlock Super
S	Female type Minifit
T	Male type Minifit

### DIGITS "2-3"



The numbers in these positions specify the termination end or the second tail.  
See "Termination Ends Type" table for coding details.

# PART NUMBERING SYSTEM

## TWO-PIECE HYDRAULIC FITTINGS (CONTINUED)

### DIGIT "4"



#### Value

#### Bending Angle

0	Special Bending Angle
1	Straight
2	22,5° Swept
3	30° Swept
4	Double connector
5	45° Swept
6	60° Swept
7	67,5° Swept
8	Compact type
9	90° Swept

### DIGIT "5"



#### Value

#### Description

0	No Nut / Male / Double skive Flange type Interlock/InterlockPlus/Xtralock
1	Crimped-back Nut / No-skive or External-skive Flange type Multifit/Spiralfit
2	Thrust-wire Nut
3	Slip-on Nut
4	Double Thrust-wire Nut
7	One-piece flange clamp (only for O8... Codes)
8	ISO/SAE code 61 split flange clamp (only for O8... Codes)
9	ISO/SAE code 62 split flange clamp (only for O8... Codes)

### DIGITS "6-7"



Tail size

### DIGITS "8-9"



Termination end size

### DIGITS "10-11-12"



These digits specify various customisations related to dimensions, threads, drops, ...

# PART NUMBERING SYSTEM

## ONE-PIECE HYDRAULIC FITTINGS

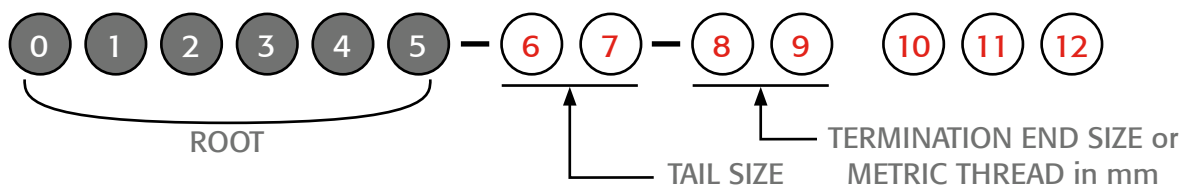

Value	Description
OPB	One-Piece (MF3000) Braided
OPNS	One-Piece (MF3000) No Skive
OPS	One-Piece (MF3000) Spiral
OPK	One-Piece (MF3000) No Skive Kompact
OPF	One-Piece (MF3000) No Skive Flat



Value	Description
1	Male
2	Female or Flange type



The numbers in these positions specify the termination end or the second tail.  
See "Termination Ends Type" table for coding details.



Value	Bending Angle
0	Special Bending Angle
1	Straight
2	22,5° Swept
3	30° Swept
4	45° Swept
6	60° Swept
7	67,5° Swept
8	Compact type
9	90° Swept

# PART NUMBERING SYSTEM

## ONE-PIECE HYDRAULIC FITTINGS (CONTINUED)

### DIGIT "5"



#### Value

#### Description

Value	Description
0	Flange type Interlock/Xtralock/Multispiral or Male
1	Crimped-back Nut or Flange type Multifit
2	Thrust-wire Nut
3	Slip-on Nut

### DIGITS "6-7"



Tail size

### DIGITS "8-9"



Termination end size

### DIGITS "10-11-12"



These digits specify various customisations related to dimensions, threads, drops, ...

# PART NUMBERING SYSTEM

## TERMINATION END TYPES

Digit	Fittings	Q.Safe	Description (Male End)	Description (Female End)
00	00	-	Double connector (same tail in two-ends connectors) / No end (plug)	No end (plug)
01	-	01	BSP Male DIN 3852-11 - ISO 1179-2 Heavy Duty "form E"	Fixed Female GAS JIS B 2351 "type O"
02	-	02	BSP Male Tapered Thread Long	BSP Female Tapered
03	03		BSP Male Parallel Thread O'R Flat Face (ISO 1179-3)	BSP Banjo
04	-	04	BSP Male Bulkhead	BSP Fixed Female DIN 3852-2 "form X" / ISO 1179-1
05	05	05	BSP Male 60° cone seat BS5200 / ISO 8434-6	BSP Female 60° cone BS5200 / ISO 8434-6
06	06	-	BSP Male Flat Face	BSP Female Flat seat
07	07	-	BSPT Male	JIS B 8363 (BSP - Nissan) Swivel Female
08	08	08	Metric Bolt DIN 7643	BSP O-Ring Female 60° cone BS5200 / ISO 8434-6
09	09	-	BSP Male O'Ring Boss Adjustable ISO 1179-3	Metric Banjo DIN 7642
10	10	-	Metric male 60° cone superlight DIN 3863	Metric female 60° cone superlight DIN 3863
11	11	11	Metric male 24° cone seat light type DIN 3861 / ISO 8434-1	-
12	12	12	Metric male 24° cone seat heavy type DIN 3861 / ISO 8434-1	Metric Female 24° cone O'Ring heavy type DIN 3865 / ISO 8434-1 Long Drop
13	13	-	-	Metric Female Multiseal cone DIN 3868
14		14	Metric Male DIN 3852-11 "form E" b/ ISO 9974-2	"Metric Fixed Female DIN 3852-1 "form X" and "form Y"
15	15	-	-	Metric Female 24° cone O'Ring light type DIN 3865 / ISO 8434-1
16	16	-	-	Metric Female 24° cone O'Ring heavy type DIN 3865 / ISO 8434-1
17	17	-	French Millimetric metric male 24° cone seat	French Millimetric metric female
18	18	-	French GAZ metric male 24° cone seat	French GAZ metric female
19	-	19	Metric Male (Adjustable + Non-Adjustable Heavy) ISO 6149-2	Metric Fixed Female ISO 6149-1
20	20	-	-	DIN Metric Standpipe L.T. DIN 2353
21	21	-	-	DIN Metric Standpipe H.T. DIN 2353
23	-	23	JIC Bulkhead male 37° cone ISO 8434-2 / SAE J514	-
24	24	24	ORFS male ISO 8434-3 / SAE J1453	ORFS female ISO 8434-3 / SAE J1453

# PART NUMBERING SYSTEM

## TERMINATION END TYPES (CONTINUED)

Digit	Fittings	Q.Safe	Description (Male End)	Description (Female End)
25	25	25	JIC male (37° cone) ISO 8434-2 / SAE J514	JIC female (37° cone seat) ISO 8434-2 / SAE J514
26	26	-	-	SAE female (45° cone seat) SAE J512
27	27	27	ORFS Bulkhead male ISO 8434-3 / SAE J1453	JIC female double hexagon 37° cone seat
28	28	28	NPTF Male 60° cone seat SAE J476a	NPSM Swivel Female 60° cone SAE J514
30	30	30	Male O'Ring Boss type SAE J1926-3	Female Port SAE J1926-1
32	-	32	Male O'Ring Boss (Adjustable + Non-Adjustable Heavy) SAE J1926-2	-
33	33	-	Flange head (not including Clamps) Code 61 without O'Ring (adapters)	Flange ISO/SAE 61 (ISO 6162-1 / SAE J518 code 61)
34	34	34	API Male	NPTF Fixed Female SAE J476a
35	35	-	NPT Male	NPT Fixed Female
36	36	-	Flange head (not including Clamps) Code 62 without O'Ring (adapters)	Flange ISO/SAE 62 (ISO 6162-2 / SAE J518 code 62)
37	37	37	Metric male 60° cone superlight DIN 3863 Bulkhead	Flange ISO/SAE 62 Plus / Flange (A/C)
38	38	-	JIS B8363 Toyota male	JIS B 8363 (Toyota) Swivel Female
39	39	-	JIS male O-Ring boss - JIS B 8363 type CO	SUPERCAT flange
40	40	-	Komatsu Metric male 60° cone seat	JIS B 8363 (Komatsu) Swivel Female
41	41	-	NPTF Swivel Male SAE J476a	Komatsu Flange
43	43	-	SAE O'Ring Boss Swivel Male	-
44	44	-	Male BSPP Flat Face Bonded Washer	ORFS Female Long Drop Elbow ISO 12151-1 / SAE
46	46	-	Super Staple Male	Super Staple Fixed Female
47	47	-	Super Staple Male (only for Interlock Plus and Spiralfit )	JIC (37° cone) Female Long Drop Elbow ISO 12151-5 / SAE J516
48	48	-	Staple Male SAE J1467	Staple Fixed Female SAE J1467
49	49	-	-	Wash Cleaning
52	52	-	SAE 45° cone Metric Thread	SAE 45° cone Metric Thread
55	55	-	BSP Parallel Thread 60° cone BS5200 (only for Interlock/Xtralock tail)	BSP Parallel Thread 60° cone BS5200 (only for Interlock/Xtralock tail)
56	56	-	Union Fitting (Male SUB)	Union Fitting (Female SUB)
57	-	-	BSP Male Tapered Thread - JIS B 8363	BSP Swivel Female (only for Interlock/Xtralock tail)
58	58	-	GOST Male	BSP Parallel Thread O'Ring 60° cone BS5200 (only for Interlock/Xtralock tail)

# PART NUMBERING SYSTEM

## TERMINATION END TYPES (CONTINUED)

Digit	Fittings	Q.Safe	Description (Male End)	Description (Female End)
59	59	-	Flushfit Male Low Pressure	Flushfit Fixed Female Low Pressure
60	-	-	Metric thread 74° cone	Metric thread 74° cone
61	61	-	Flushfit Male High Pressure	Flushfit Fixed Female High Pressure
62	62	-	Male Metric Thread 24° cone heavy type DIN 3861 (only for Interlock/Xtralock tail)	Flushfit Swivel Female Low Pressure
63	63	-	Type M Female 58° cone	-
64	-	-	BSP Male front seal Flushfit Swivel Female High Pressure	-
66	66	-	-	Metric Female 24° cone O'Ring heavy type DIN 3865 / ISO 8434-2 (only for Blastlock / Xtralock); Grayloc Hub (only for Drilling)
67	67	-	Standard SSKV	Standard SSKV
68	68	-	Super SSKV	Super SSKV
74	74	-	ORFS type (only for Interlock/Xtralock tail)	ORFS type (only for Interlock/Xtralock tail)
75	75	-	JIC Thread 37° cone (only for Interlock/Xtralock tail)	JIC Thread 37° cone (only for Interlock/Xtralock tail)
76	76	-	Expansion valve short pilot (A/C)	ISO 6164 FLANGE type 40MPa / Expansion valve (A/C)
77	-	77	DIN Bulkhead Male 24° cone Light type ISO 8434-1	-
78	78	-	"NPTF Male 60° cone seat SAE J476a (only for Interlock	Blastlock/Xtralock)"
79	79	-	Fixed Male O'Ring seat (A/C)	HUB API 16A (type 16BX) / Female O'Ring (A/C)
80	80	-	Male Swivel O'Ring (A/C)	FLANGE API 6A (type 6B/6BX) / O'Ring short pilot (A/C)
81	81	-	Male Grooved	French GAZ Standpipe
82	-	82	French GAZ Bulkhead metric male 24° cone seat	Staple Lock Swivel Female
83	83	-	4-Bolts Flange head Code 61 without O'Ring (adapters)	Flange ISO/SAE 61 (ISO 6162-1 / SAE J518 code 61) / 4-Bolts Flange head Code 61 (adapters)
84	84	-	-	Xtraflange 61 (ISO6162-1 / SAE J518 code 61 port compatible)
85	85	-	-	XtraFlange 62 (ISO 6162-2 / SAE J518 code 62 port compatible)
86	86	-	4-Bolts Flange head Code 62 without O'Ring (adapters)	Flange ISO/SAE 62 (ISO 6162-2 / SAE J518 code 62) - only for Xtralock / 4-Bolts Flange head Code 62 (Adapters)

# PART NUMBERING SYSTEM

## TERMINATION END TYPES (CONTINUED)

Digit	Fittings	Q.Safe	Description (Male End)	Description (Female End)
87	87	87	DIN Bulkhead Male 24° cone Heavy type ISO 8434-1	ASME B16.5 FLANGE / SDB compressor (A/C)
88	-	-	Male Metric Tapered Thread	Male Metric Tapered Thread
89	89	-	SUPERCAT flange (only for Interlock/Xtralock tail)	SUPERCAT flange (only for Interlock/Xtralock tail)
91	91	-	-	Gear Pump Flange
92	92	-	-	NSD ( Non Stop Driller) Clamp Connection
95	95	-	Brazing Pipe (Fittings)	Brazing socket (Fittings) / Beveled To Weld (only Drilling)
97	97	-	Metric Male with 90° Male Cone ISO 4038	Metric Female DIN 74225

Digits	Easy-Fit / Fast-Fit
1H	Oyster High Pressure
2H	Easy-Fit High Pressure (Cejn)
1L	Easy-Fit Low Pressure (Oyster)
3H	Fast-Fit

Digits	Accessories for connectors (08...)
33	Clamps for flange ISO/SAE 61
36	Clamps for flange ISO/SAE 62
85	Xtraflange Clamps
02	BSP Bolt
08	BSP Bolt Double Hole
08	Metric Bolt DIN 7643
2H	Cartridge for Easy-Fit High Pressure
00	Drilling Safety Clamp
00	Drilling Lift Eye
20	Anti-Kink
21	Metal Sleeve
41	2 Holes Flange Clamp
42	Armour - Joint
81	Clamps for Male Grooved



# PART NUMBERING SYSTEM

## HYDRAULIC QUICK COUPLINGS

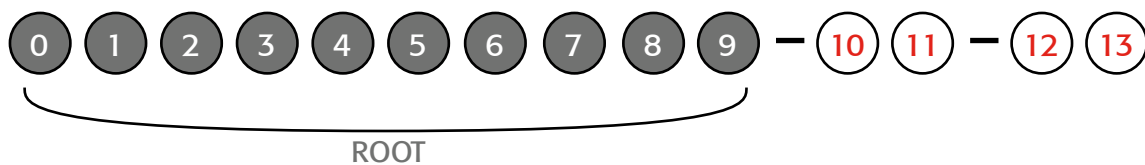

DIGIT "0"	0	1	2	3	4	5	6	7	8	9	10	11	12	13
Value	Description													
Q	Quick Coupling													

DIGIT "1"	0	1	2	3	4	5	6	7	8	9	10	11	12	13
Value	Description													
0	Hydraulic													

DIGITS "2-3"	0	1	2	3	4	5	6	7	8	9	10	11	12	13
Quick Coupling Series - refer to "Quick Coupling Series" table														

DIGIT "4"	0	1	2	3	4	5	6	7	8	9	10	11	12	13
Value	Material													
1	Steel													
2	AISI 316													
3	AISI 303													
4	Brass													
5	Aluminium													

DIGIT "5"	0	1	2	3	4	5	6	7	8	9	10	11	12	13
Value	Seal Material													
0	None													
1	NBR (Nitrile)													
2	HNBR													
3	FKM (Viton, FPM)													
4	CR (Neoprene)													
5	EPDM													
6	FFPM (Kalrez)													
7	NBR - Low Temperature													
8	VMQ (Silicone Rubber)													
9	AU (Polyurethane)													
A	PTFE													

# PART NUMBERING SYSTEM

## HYDRAULIC QUICK COUPLINGS (CONTINUED)

### DIGITS "6-7"



The numbers in these positions specify the termination end.  
See "Termination Ends Type" table for coding details.

### DIGIT "8"



#### Value

#### Description

0	Male
1	Female

### DIGIT "9"



A letter in this position indicates a customised version.

### DIGITS "10-11"



The numbers in this position indicate the Quick Coupling size.

### DIGITS "12-13"



The numbers in this position indicate the thread size.

# PART NUMBERING SYSTEM

## HYDRAULIC QUICK COUPLING TAILS

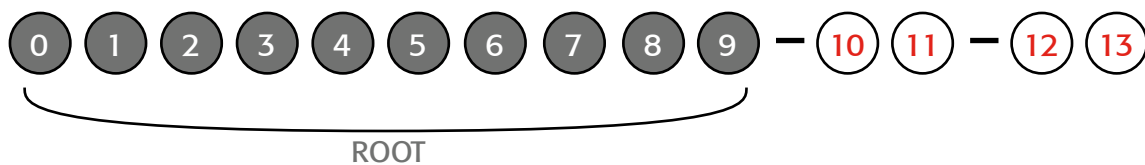

DIGIT "0"	0	1	2	3	4	5	6	7	8	9	10	11	12	13
Value	Description													
Q	Quick Coupling													

DIGIT "1"	0	1	2	3	4	5	6	7	8	9	10	11	12	13
Value	Description													
3	Q. Tail													

DIGITS "2-3"	0	1	2	3	4	5	6	7	8	9	10	11	12	13
Quick Coupling Series - refer to "Quick Coupling Series" table														

DIGIT "4"	0	1	2	3	4	5	6	7	8	9	10	11	12	13
Value	Material													
1	Steel													
2	AISI 316													
3	AISI 303													
4	Brass													
5	Aluminium													

DIGIT "5"	0	1	2	3	4	5	6	7	8	9	10	11	12	13
Value	Seal Material													
0	None													
1	NBR (Nitrile)													
2	HNBR													
3	FKM (Viton, FPM)													
4	CR (Neoprene)													
5	EPDM													
6	FFPM (Kalrez)													
7	PTFE													
8	VMQ (Silicone Rubber)													
9	AU (Polyurethane)													

# PART NUMBERING SYSTEM

## HYDRAULIC QUICK COUPLING TAILS (CONTINUED)

### DIGITS "6-7"



**Value**

**Insert Type**

MF

Multifit type

### DIGIT "8"



**Value**

**Insert Angle**

1

Straight

### DIGIT "9"



A letter in this position indicates a customised version.

### DIGITS "10-11"



The numbers in this position indicate the Quick Coupling size.

### DIGITS "12-13"



The numbers in this position indicate the Insert size.

# PART NUMBERING SYSTEM

## HYDRAULIC QUICK COUPLING PLUGS, SEALS & CARTRIDGES

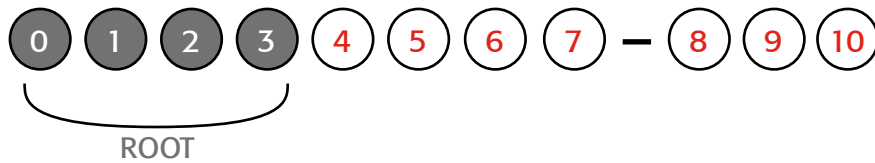

**Value** **Description**

Q	Quick Coupling
---	----------------



**Value** **Description**

1	Plugs and Seals
---	-----------------



Quick Coupling Series - refer to "Quick Coupling Series" table



**Value** **Material**

0	None
1	Steel
2	AISI 316
3	AISI 303
4	Brass
5	Aluminium
A	PE (polyethylene)
B	PVC
C	PA (polyamide)
D	POM (acetalic resin)

# PART NUMBERING SYSTEM

## HYDRAULIC QUICK COUPLING PLUGS, SEALS & CARTRIDGES (CONTINUED)

### DIGIT "5"



Value	Seal Material
0	None
1	NBR (Nitrile)
2	HNBR
3	FKM (Viton, FPM)
4	CR (Neoprene)
5	EPDM
6	FFPM (Kalrez)
7	PTFE
8	VMQ (Silicone Rubber)
9	AU (Polyurethane)

### DIGIT "6"



Value	Function
0	Simple cap / plug
1	EcoCap (with oil recycle)
2	Automatic cap
3	Seal
4	Parking
5	Cartridge

### DIGIT "7"



Value	Colour
N	Not specified or natural
R	Red
B	Blue
Y	Yellow
G	Green
K	Black
W	Brown
H	White
O	Orange
E	Grey

### DIGITS "8-9"



Quick coupling size - corresponds to nominal internal hose diameter recommended for use with the coupling (see ISO 4397)

### DIGIT "10"



Free digit for Version or other.

# PART NUMBERING SYSTEM

## HYDRAULIC QUICK COUPLING SERIES

QC Series	Plug & Seals Series	Description	
01	A0	Male according to ISO 7241-1 standards, series A	Free flow
02		Male according to ISO 7241-1 standards, series A	Poppet valve
03		Male according to ISO 7241-1 standards, series A	Ball valve
04		Male according to ISO 7241-1 standards, series A	Poppet valve, special guidevalve
05		Male according to ISO 7241-1 standards, series A	Ball valve, special guidevalve
06		Male according to ISO 7241-1 standards, series A	Connectable under pressure
07	A1	Female according to ISO 7241-1 standards, series A	Free flow
08		Female according to ISO 7241-1 standards, series A	One-way release, poppet valve
09		Female according to ISO 7241-1 standards, series A	One-way release, ball valve
10		Female according to ISO 7241-1 standards, series A	One-way release, connectable under pressure
11		Female according to ISO 7241-1 standards, series A	One-way release, connectable with male under pressure
12		Female according to ISO 7241-1 standards, series A	One-way release, connectable with both parts under pressure
13		Female according to ISO 7241-1 standards, series A	Two-ways release, poppet valve
14		Female according to ISO 7241-1 standards, series A	Two-ways release, ball valve
15		Female according to ISO 7241-1 standards, series A	Two-ways release, connectable under pressure
16		Female according to ISO 7241-1 standards, series A	Two-ways release, connectable with male under pressure
17		Female according to ISO 7241-1 standards, series A	Two-ways release, connectable with both parts under pressure
18		Female according to ISO 7241-1 standards, series A	Rigid, two-ways release, connectable with male under pressure
19		Female according to ISO 7241-1 standards, series A	Rigid, two-ways release, connectable with both parts under pressure

# PART NUMBERING SYSTEM

## HYDRAULIC QUICK COUPLING SERIES (CONTINUED)

QC Series	Plug & Seals Series	Description	
20	A2	Male according to ISO 7241-1 standards, series B	Free flow
21		Male according to ISO 7241-1 standards, series B	Poppet valve
22		Male according to ISO 7241-1 standards, series B	Ball valve
23	A3	Female according to ISO 7241-1 standards, series B	Free flow
24		Female according to ISO 7241-1 standards, series B	One-way release, poppet valve
25		Female according to ISO 7241-1 standards, series B	One-way release, ball valve
26		Female according to ISO 7241-1 standards, series B	Safety sleeve, poppet valve
27		Female according to ISO 7241-1 standards, series B	Safety sleeve, ball valve
28	A4	Male standard series	Free flow
29		Male standard series	Poppet valve
30		Male standard series	Ball valve
31	A5	Female standard series	Free flow
32		Female standard series	One-way release, poppet valve
33		Female standard series	One-way release, ball valve
34		Female standard series	Safety sleeve, poppet valve
35		Female standard series	Safety sleeve, ball valve
36		Female standard series	Two-ways release, poppet valve
37	A6	Compact Male	Free flow
38	A7	Compact Female	Free flow
39	A8	Flat face male according to ISO 16028	
40		Flat face male according to ISO 16028	Connectable under pressure
41	A9	Flat face female according to ISO 16028	With safety sleeve
42		Flat face female according to ISO 16028	Without safety sleeve
43	A8	Flat face male according to ISO 16028	Working Pressure 35MPa
44	A9	Flat face female according to ISO 16028	Working Pressure 35MPa
45	AC	Male for diagnostic purpose according to ISO 15171	
46	AD	Female for diagnostic purpose according to ISO 15171	



# PART NUMBERING SYSTEM

## HYDRAULIC QUICK COUPLING SERIES (CONTINUED)

QC Series	Plug & Seals Series	Description	
47	AE	Male for hydraulic braking circuit according to ISO 5676	
48	AF	Female for hydraulic braking circuit according to ISO 5676	
49	AG	Screw type male for hydraulic braking circuit	
50	AH	Screw type female for hydraulic braking circuit	
51	AI	Screw type male for german market	
52	AJ	Screw type female for german market	
53	AK	Screw type male for very high pressure	
54	AL	Screw type female for very high pressure	
55	AM	Screw type male for hydraulic cylinder	
56	AN	Screw type female for hydraulic cylinder	
57	AP	Screw type male for truck	
58	AQ	Screw type female for truck	
59	AR	Compact Flat face male Screw type	
60	AS	Compact Flat face female Screw type	
61	AI	Screw type male for german market	Heavy duty
62	AJ	Screw type female for german market	Heavy duty
63	AT	Screw type male for U.S. market	(Not available in other markets - No catalogue)
64	AU	Screw type female for U.S. market	(Not available in other markets - No catalogue)
65	A1	Female according to ISO 7241-1 standard, series A	Rigid, two ways release
66	AV	Flat face male Screw type	
67	AW	Flat face female Screw type	

# PART NUMBERING SYSTEM

## HOSE PROTECTIONS

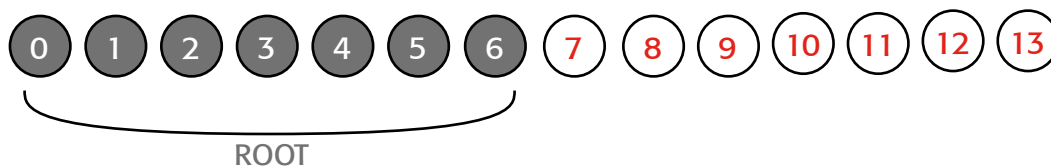

### DIGIT "0"



**Value**

**Description**

J	Always means "Accessories"
---	----------------------------

### DIGIT "1"



**Value**

**Description**

P	Always means "Protection"
---	---------------------------

### DIGIT "2"



**Value**

**Protection Type**

1	Spring
2	Sleeve
3	Clinch
4	Flexible armour

### DIGIT "3"



**Value**

**Material**

1	Polyethylene
2	Polyamide
3	Polyester
4	Silicone
5	Stainless steel
6	Steel

### DIGIT "4"



**Value**

**Colour**

B	Black
Y	Yellow
A	Orange
G	Grey
M	Metal
T	Other

# PART NUMBERING SYSTEM

## HOSE PROTECTIONS (CONTINUED)

### DIGITS "5-6"



#### Value

#### Product Family

01	Protection spring
02	Mining protection spring
03	HT Protection spring
04	Light protection spring
05	Fire sleeve
06	Textile sleeve
07	Round metal sleeve
08	Heat protection spring
09	BOP hose flexible armour
10	Clinch

### DIGITS "7-8-9"



The numbers in these positions indicate the internal diameter in mm.

### DIGITS "10-11-12-13"



Letters and numbers in these positions describe branding, packaging or special length information.

#### Value

#### Branding Information

E	Embossed / Embedded
I	Inkjet
T	Textile

#### Value

#### Packaging Information

0	Embossed / Embedded
---	---------------------

#### Value

#### Branding

99	Standard
----	----------

# PART NUMBERING SYSTEM

## RING AND SEAL

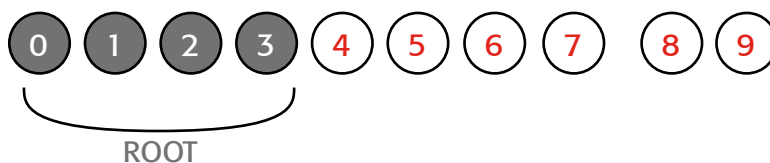

### DIGIT "0"



#### Value

#### Description

J

Always means "Accessories"

### DIGIT "1"



#### Value

#### Description

0

Always means "Rings"

### DIGITS "2-3"



#### Value

#### Description

#### Value

#### Description

01

O'ring for SAE 3000 and 6000 PSI flange

16

kit bonded seal rings

02

O'ring imperial size

17

kit copper sealing rings

03

O'ring metric size

18

kit O'ring metric size

04

O'ring for Staple Lock

19

O'ring for ORFS

05

O'ring for MSAE

20

O'ring for H.P washer fitting

06

O'ring and metallic anti-extrusion ring for metric series

21

O'ring for refri fitting

07

O'ring for BSPP

22

Cylindrical seal for refri connector

08

Metallic anti-extrusion ring for male BSPP

23

O'ring for Super Staple Lock

09

O'ring for ETCAO

24

Metal sealing ring for banjos

10

Flat seal built in

25

Metal sealing ring for pressure gauge connectors

11

Copper sealing ring

26

Soft sealing ring for banjos

12

Bonded seal ring

27

Elastomeric (captive) seal - NBR

13

Flange counter-ring for "Caterpillar" insert

28

Elastomeric (captive) seal - Viton

14

Seal type for SAE 3000 and 6000 PSI flange

29

Interlock Plus O-Ring

15

Support plastic ring (open ring)

30

One-piece Polyurethane seal for Staple Low Pressure (Yellow)

31

One-Piece Polyurethane seal for Staple High Pressure (Red)

# PART NUMBERING SYSTEM

## RING AND SEAL

### DIGITS "4-5"



The numbers in these positions indicate the external diameter in mm.

### DIGITS "6-7"



The numbers in these positions indicate the internal diameter in mm.

### DIGITS "8-9"



The numbers in these positions indicate the axial thickness in mm.



# HOSE INSTALLATION GUIDE

## INCORRECT USE

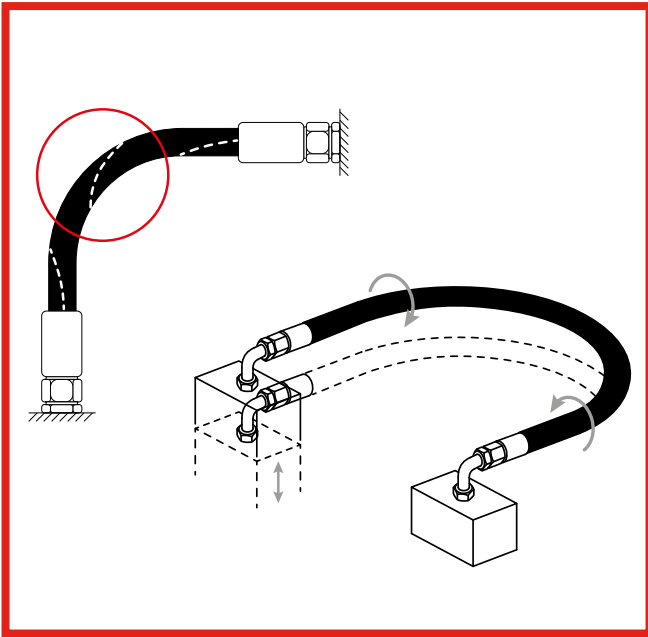

## CORRECT USE

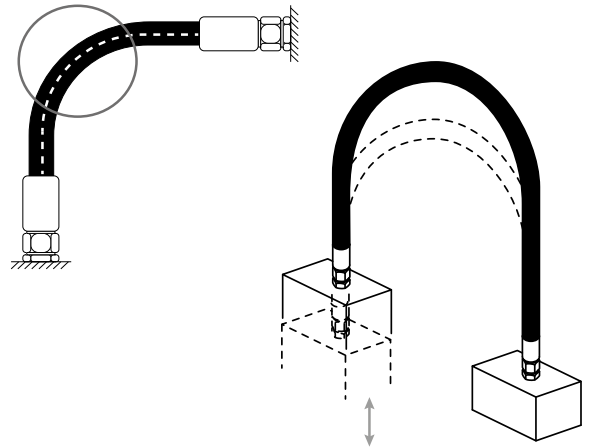

- Avoid twisting the hose assembly when installing.
- Avoid situations where moving parts will cause twisting effects on the hose assemblies after installation.

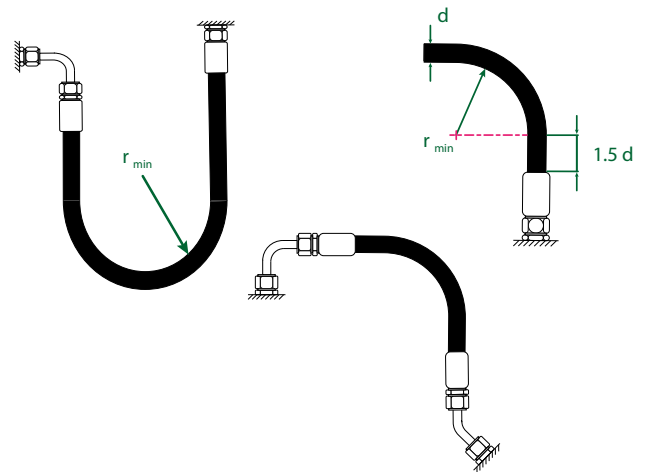
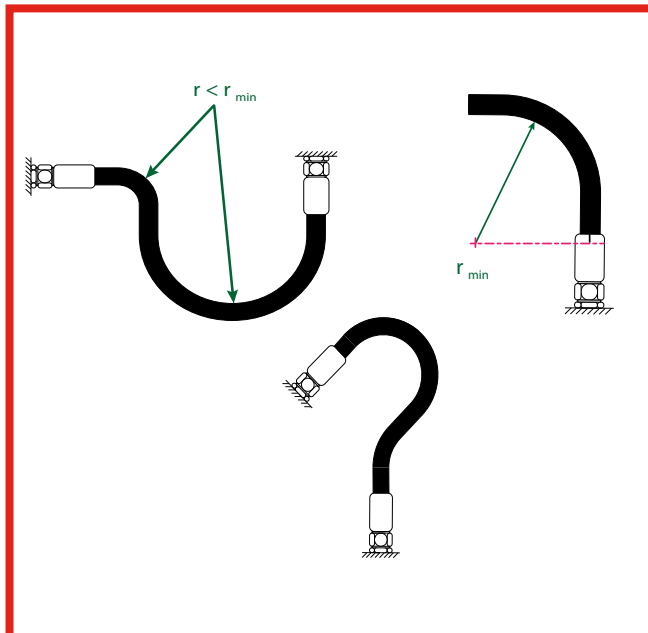

- Select the correct fittings to avoid tight bend radii.
- Ensure a minimum distance of 1.5 x "d" after the ferrule before hose bending.

# HOSE INSTALLATION GUIDE

## INCORRECT USE

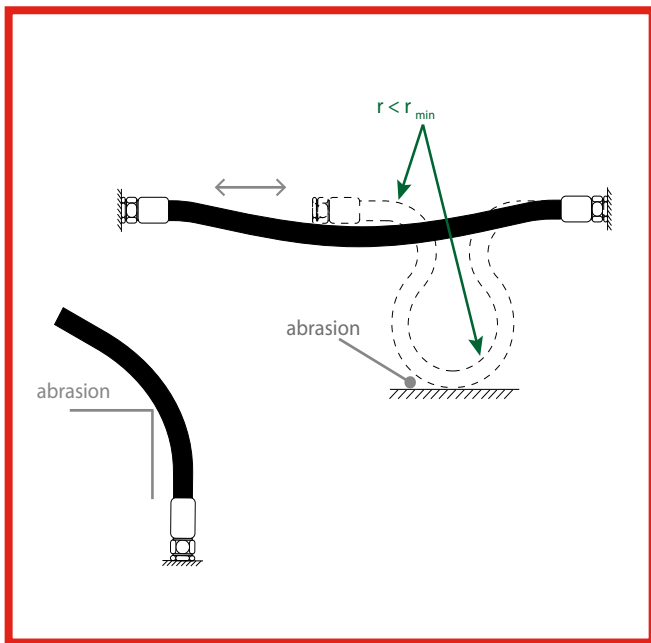

## CORRECT USE

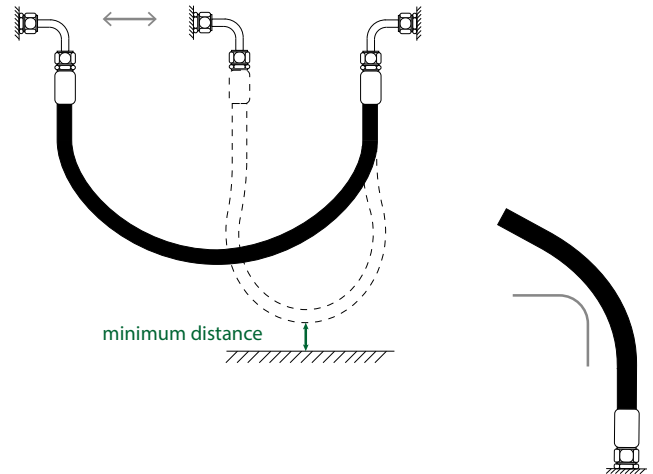

- Avoid interference with objects that can cause abrasion or damage to the hose.
- In flexing applications ensure that the hose is not subjected to tensile stresses or to impacts / abrasion from the surrounding environment.

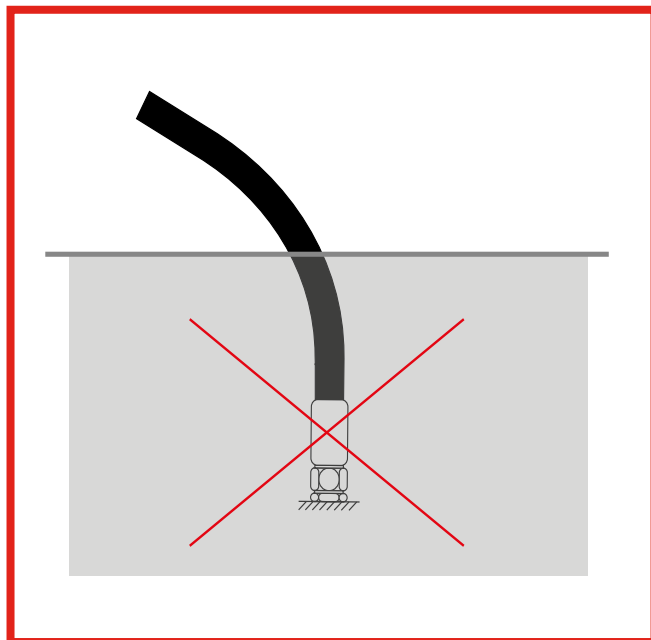

The Manuli hydraulic hose product range is not designed for immersion in the service fluid. This type of special application should be avoided or carefully studied with reference to the hose specifications.

For detailed information concerning recommended practices for hydraulic hose assemblies, please refer to **SAE J1273**. This document should be used as a guide when selecting, routing, fabricating, installing, replacing, maintaining and storing hose for hydraulic systems.



# HOSE INSTALLATION GUIDE

## PRODUCT SELECTION AND INSTALLATION

The information in this document concerning hoses, fittings and other items manufactured and provided by Manuli Rubber Industries and its subsidiaries, is provided for the express purpose of aiding in the correct selection of products for particular applications. However it is the responsibility of the customer to ensure that they consider the specific details of the application during the selection process.

Important factors to consider include:

- Hose size
- Hose length
- Fluid compatibility
- Ambient and operating temperatures
- System operating pressures
- Static head pressures
- Installation design
- Minimum bend radii
- Possible abrasion of the hose
- Movement and flexing of the hose during operation

Improper selection and / or installation of hydraulic hose assemblies can result in reduced assembly life, equipment failure, property damage, bodily injury or death.

## HOSE INTEGRATION

Manuli hoses and fittings are designed to be part of an integrated hose assembly system. As such they should only be used together or in conjunction with other types of fittings recommended by Manuli Rubber Industries and its subsidiaries. Failure to observe these requirements may result in a reduced lifespan of the hose assemblies or other failures which can cause equipment failure, property damage, bodily injury or death.

Manuli provides guidelines for the proper assembly, installation, maintenance and use of its products and further information on recommended practices is available in [SAE J1273](#).

Should you have any questions regarding proper assembly, installation or application usage of any Manuli product, please contact our Technical Centre in Italy.

## WARNING!

**Improper selection or use of any of the products found in this document may result in property damage, bodily injury or death. Consider all aspects of your application carefully to ensure that the products selected are the most appropriate for the task.**

Manuli Rubber Industries reserves the right to modify the data provided in this catalogue without notice.

© Copyright 2015 Manuli Rubber Industries S.p.A. All rights reserved.

No part of this document may be reproduced or transmitted, in any form or by any means, without the express written permission of Manuli Rubber Industries.

# SALES TERMS AND CONDITIONS

**STANDARD TERMS AND CONDITIONS OF SALES<sup>®</sup> MANULI HYDRAULICS GROUP ("MHG") ALL GOODS AND SERVICES PROVIDED BY MHG ARE FURNISHED ONLY ON THE TERMS AND CONDITIONS STATED BELOW:**

**1. PURPOSE.** These standard terms and conditions of sales apply to the relationship involving the supply of products by any company owned or controlled by Manuli Rubber Industries S.p.A. operating in the Manuli Hydraulics Group (referred to below as MHG) to professional operators (referred to below as Buyer or Buyers).

**2. SUPPLY ORDERING PROCESS.** The Buyer may issue purchase orders to MHG in the following ways:

**2.A)** By fax

**2.B)** By e-mail

**2.C)** On-line, only in the case of Buyers previously authorized to do so by means of a suitable activation procedure. This activation is essential if orders are to be placed on-line. The Buyer activation is by allocation of an identity code (user-id) and password to enable it to be recognized each time an order is placed, and takes place by filling in and returning the schedule set out in the home page of MHG's web site as described in the Request for Information section. The Buyer has the right to refuse the request for activation or cancel an existing activation.

**3. CONTRACT FORMATION.** All orders for MHG goods are subject to written acceptance by MHG by e-mail, fax or post. For on-line orders to MHG as described in point 2.C above, the authorized Buyer is first identified through his user-id and password, then selects the products, quantities and delivery address as guided by the system and issued the supply order. The order sent to MHG on-line is accepted only if specifically confirmed by this latter by email, fax or post.

Any and all terms in Buyer's purchase orders, acknowledgments, confirmations, or other business forms ("Buyer's Forms") which vary, conflict with or add to, or are in any way inconsistent with, the terms provided below are REJECTED by MHG and shall not be part of any agreement between the Buyer and MHG unless specifically agreed to in a writing document signed by MHG. MHG's acceptance of a purchase order or the commencement of performance by MHG shall neither change nor add to this Agreement;

**THE TERMS PROVIDED BELOW SHALL PREVAIL OVER ANY VARYING, ADDITIONAL OR CONFLICTING TERMS IN THE BUYER'S FORMS.**

For all on-line orders, these Standard Terms and Conditions of Sale, as available to the Buyer on the web site [www.manuli-hydraulics.com](http://www.manuli-hydraulics.com), are applicable.

**4. INFORMATION MADE AVAILABLE TO THE BUYER.** Before the issue of the purchase order, MHG will provide the Buyer with all the commercial information on the products that it may require. After the order has been placed, MHG will inform the Buyer of the stages of the order through MHG service structure or, for those Buyers in possession of User\_ID and Password, through MHG's web site.

**5. PRICES.** MHG reserves the right to alter the prices, discounts and payment conditions in force when the contract is confirmed and the Buyer expressly acknowledges and agrees upon such right. However, any modifications will become effective after notification of these has been issued, and they will apply only to the part of the supply that has not been completed. In such a case the Buyer may cancel the contract for the part not completed within 2 (two) weeks of the issue of notification of the increase and MHG shall have no liability, directly or indirectly, whatsoever.

**6. TAXES.** Prices do not include country, federal, state or local taxes, now or hereafter enacted, applicable to the goods sold, which tax or taxes will be added by MHG to the sales prices where MHG has the legal obligation to collect them, and will be paid by the Buyer or reimbursed by the Buyer to MHG if paid by MHG, unless the Buyer provides MHG with a proper tax exemption certificate.

**7. SHIPPING, TITLE AND DELIVERY.** Shipments shall be EXW as such term is defined in the Incoterms 2000, unless differently agreed upon in writing. Shipping dates are approximate and are based to a great extent on prompt receipt by MHG of all necessary information from the Buyer. MHG shall not be liable for any loss or expense incurred by the Buyer in the event that MHG fails to meet the specified delivery schedule(s) due to production or other delays due to unforeseen circumstances. Buyer must collect the products within 5 working days from the declaration by MHG of readiness for shipment EXW. For shipment FCA or FOB, Buyer must notify MHG with all necessary information for the shipment FCA or FOB within 10 working days from the declaration by MHG of readiness for shipment. In case of not respect of the above mentioned period, MHG will have the right to terminate the order or to store the products at MHG's warehouse at risk and expense of the Buyer at a rate of €0,5 per day per pallet. Unless differently agreed upon in writing, shipments shall be only for Lot or multiple of Lot for each product code. The term "Lot" is the minimum order quantity for each product code as indicated in the current price list/catalogue and must be a multiple of the minimum quantity per product code.

**8. WITHDRAWAL RIGHT.** In case of communication by MHG of his impossibility to respect the shipping date indicated in the confirmation of order, and unless a new shipping date will be agreed upon in writing, the Buyer can, waiving any other rights, withdraw the order by means of written notice to be sent to MHG within 7 days from the communication of MHG.

**9. RETURNS.** MHG will accept returns only upon prior agreement and at conditions to be defined between the parties.

**10. TOLERANCES.** Due to MHG's requirements, tolerances of +/-10% of the confirmed quantities, as and if applicable, are always allowed and accepted.

**11. PAYMENT.** Payment shall be made within the agreed upon period from the date of invoice, in the agreed upon currency at the address shown on the invoice. If payment in full is not received by MHG by the due date, the Buyer shall be in breach hereof. In the event of late payment, the Buyer will incur an interest charge calculated at the reference rate of the local national central bank plus 2 percentage points per year on the unpaid balance to cover the administration costs of collection. Moreover, MHG reserves the right to suspend all further deliveries, to recover all unpaid materials and to require an immediate payment of all

# SALES TERMS AND CONDITIONS

other claims. Such charges may be in addition to other remedies exercisable by MHG. The amount of credit may be changed or credit withdrawn by MHG at any time. On any order on which credit is not extended by MHG, shipment or delivery shall be made, at MHG's election, Cash on order (in whole or part), letters of credit with all costs of collection paid by the Buyer or other terms as agreed between the parties.

**12. SUSPENSION OF THE CONTRACT.** Should the Buyer fail to comply in whole or in part even with only one of the supply conditions or if there are any changes of any kind in the Buyer's company name, form or trading capacity, as well as in the event of proven difficulty in meeting the payments to MHG or third parties, MHG will have the right to suspend any further deliveries and convert any premiums that have matured, bank transfers or other deeds of payment unless a suitable guarantee is issued.

**13. FORCE MAJEURE.** MHG shall not be responsible for any delay or failure to perform due to causes beyond its reasonable control. These causes shall include, without limitation, fire, flood, earthquake, accident, acts of the public enemy, war, acts of terrorism, riot, epidemic, quarantine restrictions, labor dispute, labor shortages, interruption of transportation, inability to secure raw materials or machinery, extraordinary increases in such raw materials prices, rationing or embargoes, acts of God, acts of Government or any agency thereof, acts of any state or local government or any agency thereof, and judicial action. Similar causes shall excuse the Buyer for failure to take goods ordered by the Buyer, provided reasonable notice is given to MHG of such contingency. However, the Buyer shall not be excused from the terms hereof for (i) any goods shipped prior to receipt of such notice; or (ii) goods already in transit when the contingency occurs.

**14. LIMITATION OF LIABILITIES. THE BUYER AND MHG AGREE THAT (I) THE SOLE AND EXCLUSIVE REMEDIES FOR BREACH OF ANY WARRANTY CONCERNING THE GOODS SHALL BE REPAIR OR REPLACEMENT OF THOSE GOODS OR THEIR COMPONENT PARTS OR REFUND OF THE PURCHASE PRICE; AND (II) MHG SHALL HAVE THE EXCLUSIVE RIGHT TO SELECT ANY SUCH REMEDY IN ITS SOLE DISCRETION. MHG SHALL NOT BE LIABLE FOR CONTINGENT, INCIDENTAL OR CONSEQUENTIAL DAMAGES TO PERSONS OR PROPERTY AND MHG'S SOLE LIABILITIES AND BUYER'S EXCLUSIVE REMEDIES HEREUNDER ARE AS PROVIDED IN THESE STANDARD TERMS AND CONDITIONS OF SALES. MHG SHALL NOT BE LIABLE FOR ANY EXCESS REPROCUREMENT COSTS, SPECIFIC PERFORMANCE OR DELAY IN DELIVERY.**

Notwithstanding any implication to the contrary, MHG shall have no liability whatsoever unless and until the Buyer shall have paid the full purchase price of all goods delivered.

**15. WARRANTY AND CLAIMS.** MHG warrants that the Products will be free of defects in material and workmanship for a period equal to twelve (12) months from the date of shipping from MHG to the Buyer or, with the sole exception of assembly machines, within two thousand (2000) hours of use, whichever comes first. In case of claims presented in the correct way and regarded as founded, MHG agrees to replace or repair the defective product when these are returned to its premises.

a. This warranty does not cover any faults caused by normal deterioration, accelerated deterioration caused by special

physical, chemical or electrochemical conditions, insufficient maintenance or incorrect repair, failure to follow the storage, user and operating instructions, use of unsuitable materials, the effects of a chemical or electrolyte process, assembly operations not carried out using only MHG's original parts or MHG's original certified parts, using MHG's assembly machines and in strict accordance with MHG's latest assembly instructions to be found always updated at [www.manuli-hydraulics.com](http://www.manuli-hydraulics.com), or any other faults arising as a result of circumstances over which the supplier has no control. This warranty does not cover faults caused by modifications made by the customer or a third party, or assembly or installation operations carried out by these latter without observance of the operating and installation conditions and/or the technical specifications of the products.

**b. IN NO EVENT SHALL MHG BE LIABLE FOR INCIDENTAL OR CONSEQUENTIAL DAMAGES. NO PRODUCT IS WARRANTED AS BEING FIT FOR A PARTICULAR PURPOSE.** The warranties described above apply only if (i) the Product has not been misused, tampered or abused in any manner nor have repairs been attempted thereon; (ii) written notice of failure within the warranty period is forwarded – exclusively by means of the form available on the website [www.manuli-hydraulics.com](http://www.manuli-hydraulics.com) to be filled in each section - to MHG and MHG's direction for properly identifying Products returned under warranty are followed; and (iii) with the return, a notice authorizing MHG to examine and disassemble returned Products to the extent MHG deems it necessary to ascertain the cause of failure. The warranties stated herein are exclusive.

**THERE ARE NO OTHER WARRANTIES, EITHER EXPRESSED OR IMPLIED, BEYOND THOSE SET FORTH HEREIN,** and MHG does not assume any other obligation or liability in connection with the sale or use of the Products.

c. The receipt by the Buyer or its customer(s) of any of the Products shall constitute the Buyer' unqualified acceptance of same and waiver by the Buyer of all claims hereunder (**OTHER THAN CLAIMS NOT DISCOVERABLE UPON RECEIPT AND INSPECTION**) unless the Buyer gives written notice of the same to MHG within eight (8) days after its receipt or, in the event of concealed defects, the claim should be sent to MHG in writing within eight (8) days of their discovery, and in any case within a period of twelve (12) months from shipping from MHG to the Buyer, or, with the sole exception of assembly machines, within two thousand (2000) hours of use, whichever comes first. In any case, whenever possible, the Buyer shall send MHG a sample of the defective product to follow up the claim procedure.

d. No claim of any kind, where as to Products delivered or for delay in delivery or failure to deliver, and whether or not based on negligence, shall be greater in amount than the purchase price of the Products with respect to which such claim is made. **IN NO EVENT SHALL MHG BE LIABLE FOR INDIRECT, INCIDENTAL SPECIAL, OR CONSEQUENTIAL DAMAGES, WHETHER OR NOT CAUSED BY OR RESULTING FROM THE NEGLIGENCE THEREOF.** It is expressly understood that any technical advice furnished by MHG with respect to the use of the Products, shall not be deemed to be a representation that the Products may be so used successfully or that such use will offer any specific result, and MHG does not assume any obligation or liability for any advice given or results obtained.

e. The Buyer shall indemnify and hold MHG harmless against

# SALES TERMS AND CONDITIONS

any and all loss damage, cost, or expense of any kind incurred by reason of any negligence, breach or other fault of the Buyer imposed by law upon MHG for damages assessed because of property damage or bodily injuries or death sustained or resulting from the sale, use, or handling of the Products except to the extent caused by the negligence of or breach of this Agreement by MHG, and the MHG has notified the Buyer in writing of any third party's claims or demands within sixty (60) days after MHG received notice thereof.

**16. RESERVE.** For the orders sent to MHG on-line, these will be accepted only after the correct completion of the activation procedure described in point 2.C above, which takes place using a user-id and password. The Buyer is aware that the revelation of the user-id and password to unauthorized parties would enable these to make orders in his name. Consequently, the Buyer will guard his identity code and password with maximum diligence and reserve, as he will be held responsible for any abusive use of these. MHG will take no responsibility for abusive use of the user-id and password, and the order will remain fully valid and effective after confirmation of it has been issued.

a. The Buyer agrees to exonerate MHG from any action, request or claim, including claims for compensation for damages, deriving directly or indirectly from the use or abuse of the user-id and password by any party.

b. The Buyer agrees to inform MHG of the loss or theft of the password, whereupon MHG will deactivate the password in question and issue a new one.

**17 ENTIRE AGREEMENT. THESE TERMS AND CONDITIONS, INCLUDING THE LIMITED WARRANTY AND DISCLAIMER AND LIMITATIONS OF LIABILITY, ARE A COMPLETE AND FULL EXPRESSION OF THE AGREEMENT BETWEEN THE PARTIES.** The terms hereof may not be varied, supplemented, qualified, modified, waived or interpreted by any prior or subsequent course of performance or conduct between the parties (including the shipment of goods hereunder) or by any usage of the trade or by conflicting or additional terms upon the face or reverse of any form to which this is attached or a part of, nor may it be modified by any agent, employee, or representatives of MHG unless such modification or representation is made in writing and signed by a duly authorized officer of MHG. Stenographic or clerical errors are subject to correction.

**18. SEVERABILITY.** If any term of this Agreement is held to be illegal or unenforceable, such term shall be severed from this Agreement and the remaining terms shall remain in force.

**18. ASSIGNS.** This Agreement shall be binding on and inure to the benefit of the successors and assigns of the entire business and goodwill of either MHG or Buyer, or of that part of the business of either used in the performance of such contract, but shall not be otherwise assignable by Buyer.

**20. PROPRIETARY RIGHTS.** Trademarks, service marks and other product identifications are MHG's property at all times and shall only be used in connection with the products. The Buyer shall not remove or deface any such marks.

**21. CORRESPONDENCE.** All correspondence regarding this contract will be sent to the MHG's Customer Service structures geographically competent:

**Manuli Rubber Industries S.p.A**

fax: +39 02 62713383;

telephone: +39 02 62713450;

email address: [service.southeu@manulirubber.com](mailto:service.southeu@manulirubber.com).

**Manuli Hydraulics Polska S.A.**

fax: +48 32 2220 147;

telephone: +48 32 2220 222;

email address: [service.northeu@manulirubber.com](mailto:service.northeu@manulirubber.com).

**Manuli Hydraulics (Suzhou) Co. Ltd.**

fax +86 512 6283 7399;

telephone and help desk: +86 512 6283 7099;

email address: [service@manuli-hydraulics.com](mailto:service@manuli-hydraulics.com)

**22. INTERPRETATION.** The validity, performance and construction of these terms and conditions and any sale made hereunder shall be governed by the laws of the Italy. All the terms hereof shall be interpreted in the manner which enhances its enforceability.





Global Sales & Marketing Office  
Suite 9A, 111 Piccadilly,  
Manchester, M1 2HY  
Phone: +44[0]161 871 1130  
Fax: +44 [0]161 247 7862



CAT0001 Rev. 1